

General Specifications

Model PH202G (S)
2-wire transmitter for pH
and Redox (ORP)



Fieldbusses are based on highly reliable bi-directional communications between "smart" field devices and HOST systems. Next to a wide range of data each smart device can provide their status which is essential for adequate control and maintenance. The famous EXA sensor diagnostics will provide asset management facilities for those who operate and maintain the plant.

"The advent of Fieldbus technology had made possible a wide range of new capabilities throughout every level of the control system that had not previously been possible or fully explored."

Yokogawa has implemented three leading process Fieldbus technologies in their 202 series: HART®, Foundation Fieldbus H1 and Profibus PA. All transmitters are provided with the important and widely used Device Description files that provide information on parameters and other data in each device, as well as the ability to include algorithmic relationships such as calibrations.

Flexibility, reliability and low maintenance are among the benefits provided by the EXA PH202 pH and redox analyzer. Designed to meet the particular requirements of measuring pH/Redox in modern industrial environments, it contains many features to ensure the best precision whatever the application.

The transmitter is housed in a robust IP65 field mountable case and combined with the easy and clear LCD makes the PH202 a complete industrial transmitter. The famous EXA sensor diagnostics are enhanced by an improved impedance check. The logbook is used to store important configuration, calibration history and diagnostic data. Prediction of sensor failure is possible by reference to the logbook.

Automatic calibration uses internal buffer tables and stability checking to ensure maximum accuracy with minimum effort. Process temperature compensation enhances accuracy in applications where the influence of temperature is seen in process pH changes. pH and redox measurements can be made simultaneously when an appropriate sensor combination is used.



Features

- Universal pH/ORP, dual high impedance inputs
- On-line sensor checking
- Event logbook in software
- Process temperature compensation
- Differential input amplifier with equipotential screening
- Freely configurable ITP, slope and assymetry potential
- Easy to use EXA control panel
- Password protection for all levels of software
- Intrinsically safe version - <Ex> II 2(1)G EEx ib[ia] IIC T4/T6

System configuration

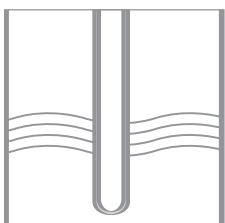

Sensors

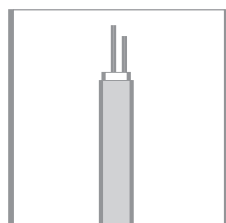

Cables

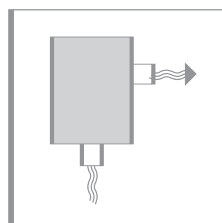

Fittings

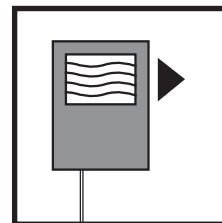

Transmitters

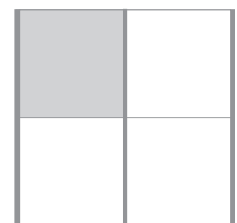

Accessories

Fieldbus

Field devices in general are becoming smarter, operations more complex and hold more information about themselves and the process. Higher communication data rates are important in handling this additional information without undue delays. Fieldbusses such as Foundation Fieldbus and Profibus PA (at 31.25 kbps) provides this capability, which is also ample for measurement values such as conductivity/resistivity, concentration and temperatures. With the PH202 it becomes possible to keep plant records up-to-date and accurate as the PH202 keeps a logbook and will therefore provide you with all this information necessary. Calibration and validation are becoming increasingly important, both because some products, like pharmaceuticals demand it. The logbook of the PH202 also holds invaluable information in the later investigation of production problems. Fieldbusses have brought major benefits to all aspects of process automation. The technology is now mature and well accepted by major end users in process and utilities markets. The Profibus PA and Foundation Fieldbus protocols use the European Standard EN50170. The physical layer is defined according to IEC 1158-2, which can also be used for intrinsically safe applications.

One of the features of smart field devices is their ability to detect faults, either in the device electronics or in an associated sensor. Using a fieldbus system, such faults are reported in the device status byte in every message (assuming that communication is still possible).

For HART[®], it is still useful to follow the convention of indicating fault conditions by setting the analogue output current to a value which is recognisably beyond the normal operating range (including the small amount of linear over-range commonly allowed). If it is still alive, the current output value is set to an appropriate value with the intention that a host system should be able to set alarm thresholds just outside the normal 4 to 20 mA range, to indicate measurement out-of-range, and to set further alarm thresholds to indicate a fault condition.

The PH202 follows the NAMUR Recommendation NE43 (18.01.1994) which suggests the following:

- Valid measurement range from 3.8 mA to 20.5 mA.
- Fault indicated by ≤ 3.6 mA or ≥ 21.0 mA. (burn)

DD specification and other support files

The PH202G(S) Device Description (DD) files are available enabling communications compatible HOST devices (and HHT for HART[®]). Other files to support AMS, PRM and PDM are available as well. For more information contact your local Yokogawa sales offices.

Accurate pH Measurement

Electrode selection

In order to make precise pH measurements, there are a number of pre-requisites. Special attention should be paid to the choice of the sensors to ensure compatibility with the chemical composition of the process fluid. The speed of response required, the solids content and the flow rate of the fluid are also contributory factors. Other Yokogawa specification sheets cover the choice of sensors. Any Yokogawa sales office can provide expert advice.

Converter design

The system should be designed to minimize the effect of external influences. The EXA series features dual high impedance input amplifiers in a differential configuration with liquid earth. This system is used to ensure compatibility with most available sensor combinations. It also provides excellent noise rejection, minimizing the stray signals that can affect industrial pH measurements. Earth loop currents in damp and damaged cabling are eliminated by the equipotential screening. EXA instruments offer a simple

and effective process temperature compensation in addition to the usual compensation to the Nernst equation.

Maintenance

It is important that the system is being well maintained. The electrodes must be properly cleaned and regularly calibrated. Yokogawa on-line cleaning systems may be used where there is significant fouling of the sensors. Other influences from the electrode holders can be less obvious, but important none the less. Well designed fittings make it easy to provide the routine maintenance needed for best accuracy. Flow through, retractable and immersion assemblies are available.

The selection of the buffer solutions is important to ensure the best possible calibration. Yokogawa strongly recommends the use of NIST (NBS) buffers. These are chosen as primary buffer standards because of the maximum buffer capacity exhibited by these solutions. Commercial buffers (adjusted with NaOH) have the limited advantage of an integer value, with the disadvantages of loss of buffer capacity and greater temperature dependence. Yokogawa sets the pH/temperature relationships for NIST buffers in the software of the EXA pH converters. This combination provides the best calibration possible.

Accessories

Buffer powder packs to NIST (NBS) standard. Each box contains five (5) packets, sufficient to make 200 ml of calibration solution when dissolved in distilled water.

Part No	pH value	Reference temperature
6C232	4.01	25°C
6C236	9.18	25°C
6C237	6.87	25°C

Dual amplifier system

The input amplifiers both have a very high input impedance ($\geq 10^{13} \Omega$). This means the PH202 is capable of accepting glass, enamel and metal measuring and reference sensors. Together with the ability to configure the ITP (isothermal point), the system can be adapted to accept almost all sensor types.

Process Temperature Compensation

The figure below shows the strong change in pH with temperature, caused by the dissociation constant of water changing. This effectively shifts the neutral point from pH 7. In order to reliably control the pH of solutions it is necessary to compensate for the changes. The EXA transmitters have a simple-to-operate system of process temperature compensation to provide optimum accuracy and best control. An application where this is particularly important is in the measurement of alkalinized boiler feed water.

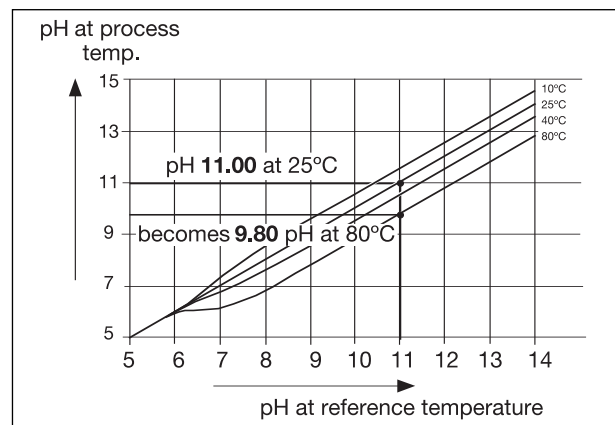

pH as a function of temperature

Connection diagram for sensors

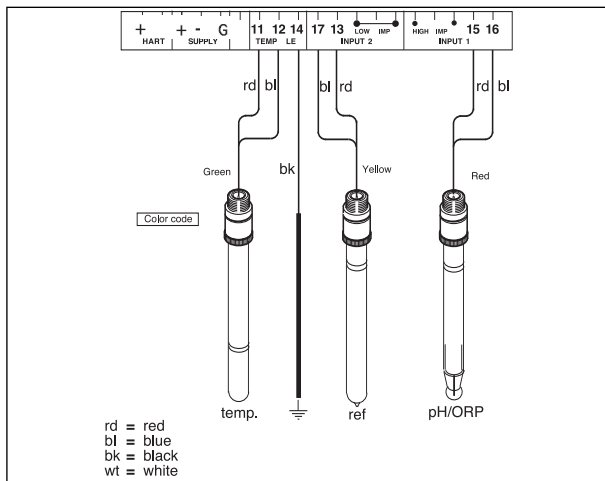

Three Level Operation

The EXA PH202 transmitter uses a 3-level operating system to take full advantage of the microprocessor while retaining the traditional simplicity of a 2-wire transmitter. Advanced functions are separated from conventional operation to avoid confusion. They can be activated as required for each individual application.

1. The normal maintenance functions are accessible through the flexible window by pushing the keys underneath.
2. Functions required to commission the instrument are hidden to discourage unauthorized tampering. The front cover is removed to reveal the commissioning menu and the hidden access key (marked V).
3. Specialized functions can be adjusted via the SERVICE menu. In this case access is by using "service codes".

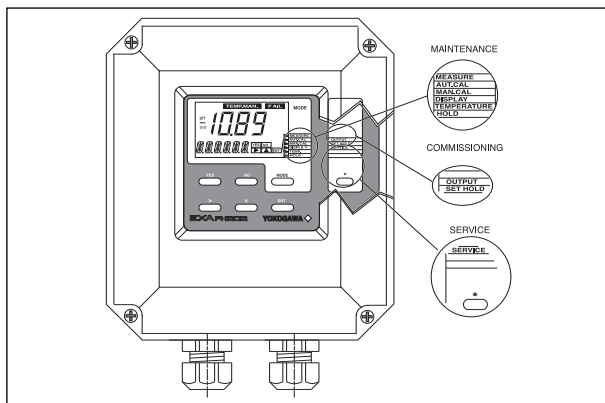

MAINTENANCE level

Use :Normal operation and checking
 How :Simple operation by dialog through the closed front cover
 Example :Calibration with buffers

COMMISSIONING level

Use :For normal commissioning
 How :Removal of the front cover reveals the access key and second menu
 Example :Selecting a measuring range

SERVICE level

Use :Only for specialist functions
 How :Through special coded entries
 Example :Process temperature compensation

With this 3-level user-friendly approach, the instrument can be operated by anyone. Commissioning is straight-forward and needs no calibration equipment compared to analog instruments. Specialist functions available via access codes are invisible during normal operation. All three levels can be separately protected against unauthorized access by a password system using a three digit code.

Sensor Checking

On-line checks

Real-time sensor checking in the 2 wire transmitter is one of the most important features of the EXA PH202 transmitter.

By special circuitry on the input board an alternating voltage is applied to the liquid earth pin and the sensors. The impedance of the measuring electrode (pH-glass or ORP-metal electrode) and reference electrode are independently measured. The measured values are compared to limiting values.

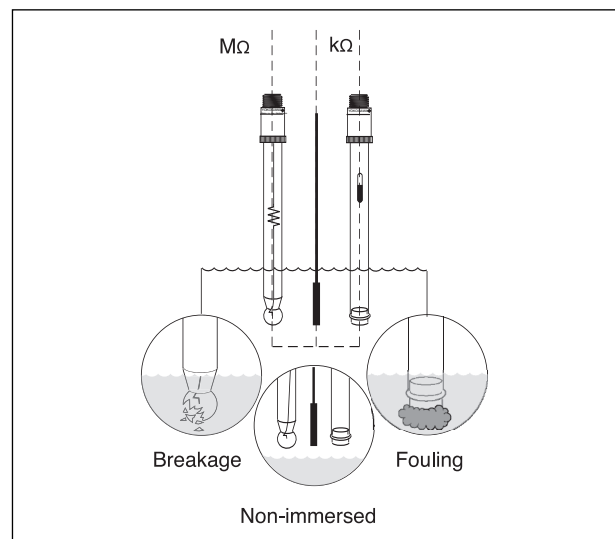

Sensor Checking

Faults

- The pH-sensor is checked for low impedance to detect breakage of the bulb and for high impedance to detect an open circuit.
- The Redox sensor is checked for high impedance to detect an open circuit.
- The reference electrode is also checked for high impedance to detect fouling of the diaphragm, poisoning of the reference liquid or non immersion of the sensors.

These faults are reported in the device status byte in every message (assuming that communication is still possible!).

For HART®, it is still useful to follow the convention of indicating fault conditions according NAMUR Recommendation NE43 (18.01.1994).

The fault is also flagged on the display by a special marker field and an error code in the message display.

Off-line checks

During calibration of a pH measuring system, the response of the sensors is measured and checked. Sensitivity and drift are calculated and checked. During calibration of an ORP measuring system, the drift of the sensors is calculated and checked. If any of these are outside the limits, an error is signaled.

The comprehensive combination of on-line and off-line checking monitors all key aspects of the measurement to give an early warning, if the reading is faulty.

General Specifications

A. Input specifications

: Dual high impedance inputs (2 x 1013 Ω) with provision for liquid earth connection. Suitable for inputs from glass or enamel pH & reference sensors and ORP metal electrodes.

B. Input ranges

- pH : -2 to 16 pH
 - ORP : -1500 to 1500 mV
 - rH : 0 to 55 rH
 - Temperature : -30 to 140°C (-20 to 300 °F)
 : 8k55 sensor -10 to 120°C (10 to 250 °F)
 : for 10k PTC sensor -20 to 140°C
 (0 to 300 °F)

C. Span

- pH : min 1 max 20 pH
 ORP : min 100 max 2000 mV
 rH : min 2 max 55 rH

D. Temperature compensation

- Range : Automatic or manual compensation to Nernst equation. Process compensation by configurable coefficient. Compensation range -30 to 140°C. Adjustable ITP (Iso-thermal point of intersection).

E. Sensor impedance checking

: Independent impedance check on measuring and reference sensor elements, with temperature compensation. Display of sensor impedance on message line of display. FAIL flag in event of "out of limits" impedance,

F. Calibration

: Semi-automatic using preconfigured NIST buffer tables 4, 7 & 9, or with user defined buffer tables, with automatic stability check. Manual adjustment to grab sample. Slope and Asymmetry Potential setting. Zero point can be selected for calibration and display instead of As. Pot. (IEC746-2)

G. Logbook

: Software record of important events and diagnostic data. Available through HART® link, with key diagnostic information available in the display.

H. Display

: Custom liquid crystal display, with a main display of 3 1/2 digits 12.5 mm high. Message display of 6 alphanumeric characters, 7 mm high. Warning flags and units (pH and mV).

J. Input isolation

: 1000 V DC

K. Cable and terminals

: The PH202 is equipped with terminals suitable for the connection of finished cables in the size range: 0.13 to 2.5 mm (26 to 14 AWG).

Cable entry

: 2 cable glands 1/2" NPT. The glands will form a tight seal on cables with an outside diameter in the range of 7 to 12 mm (9/32 to 15/32 inches).

L. Shipping Details

: Package size w x h x d; 290 x 225 x 170mm (11.5 x 8.9 x 6.7 inch)
 Packed weight approx. 2.5 kg (5lb)

M. Housing

: Cast aluminum case with chemically resistant coating, cover with flexible polycarbonate window. Case color is off-white and cover is moss green. Cable entry is via two PG 13.5 polyamide glands. Cable terminals are provided for up to 2.5 mm² finished wires. Weather resistant to IP65 and NEMA 4X standards. Pipe, wall or panel mounting, using optional hardware.

Operating specifications

- A. Performance** : pH
 - Linearity : $\leq 0.01 \text{ pH} \pm 0.02 \text{ mA}$
 - Repeatability : $< 0.01 \text{ pH} \pm 0.02 \text{ mA}$
 - Accuracy : $\leq 0.01 \text{ pH} \pm 0.02 \text{ mA}$
- Performance** : ORP
 - Linearity : $\leq 1 \text{ mV} \pm 0.02 \text{ mA}$
 - Repeatability : $< 1 \text{ mV} \pm 0.02 \text{ mA}$
 - Accuracy : $\leq 1 \text{ mV} \pm 0.02 \text{ mA}$
- Performance** : Temperature with Pt1000 Ω ,
 3 k Ω Balco, 5 k1 Ω , 8k55 Ω , 350 Ω ,
 6k8 Ω and NTC 10k Ω
 - Linearity : $\leq 0.3^\circ\text{C} \pm 0.02 \text{ mA}$
 - Repeatability : $< 0.1^\circ\text{C} \pm 0.02 \text{ mA}$
 - Accuracy : $\leq 0.3^\circ\text{C} \pm 0.02 \text{ mA}$
- Performance** : Temperature with Pt100 Ω
 - Linearity : $\leq 0.4^\circ\text{C} \pm 0.02 \text{ mA}$
 - Repeatability : $< 0.1^\circ\text{C} \pm 0.02 \text{ mA}$
 - Accuracy : $\leq 0.4^\circ\text{C} \pm 0.02 \text{ mA}$
- B. Ambient operating temperature**
 : -10 to + 55°C (10 to 131°F)
 Excursions to -30°C do not influence the current output function, and excursions to +70°C are acceptable too.
- C. Storage temp.** : -30 to +70°C (-20 to 160°F)
- D. Humidity** : 10 to 90% RH
- E. Data protection** : EEPROM for configuration and logbook, and lithium cell for clock.
- F. Watchdog timer** : Checks microprocessor
- G. Automatic safeguard** : Return to measuring mode when no keystroke is made for 10 min.
- H. Operation protection** : 3-digit programmable password.
- J. Intrinsic safety (PH202S only)**
 Ⓢ II 2(1)G
 - Cenelec ATEX : EEx ib [ia] IIC T4 for Tamb. < 55°C
 - Cenelec ATEX : EEx ib [ia] IIC T6 for Tamb. < 40°C
 - CSA : Ex ia Class I, Division 1, Group C&D, T3C for Tamb. < 55°C
 - FM : Class I, Division 1, Group ABCD T3B for Tamb. < 55°C T4 for Tamb. < 40°C
- K. Non-Incendive** Ⓢ II 3(1)G
 - Cenelec ATEX : EEx na [L] IIC T4 for Tamb. < 55°C
 - Cenelec ATEX : EEx na [L] IIC T6 for Tamb. < 40°C
 - FM : N.I. Class I, Div. 2, Group ABCD T4 for Tamb. < 55°C T6 for Tamb. < 40°C
- L. Regulatory compliance**
 - EMC : meets council directive 89/336/EEC
 - Emission : meets EN55022 class A
 - Immunity : meets EN61000-6-2
 - ATEX : meets directive 94/9/EC

HART® Communications

- Input** : Two-wire system, 4-20 mA
- Power supply** : Nominal 24 volt DC loop powered system.
 PH202G : up to 40 volts
 PH202S : up to 31.5 volts
- Note:** : The transmitter contains a switched power supply, drawing its energy from the 0-4 mA section of the signal. Consequently the 17 volt limit is applied at 4 mA. The characteristic of the unit is such that above about 7 mA on the output, the terminal voltage can drop to 14.5 volts without problem. (see fig. 1)
- Transmission** : Isolated output of 4 to 20 mA DC.
- Signal** : Maximum load 425 Ω . (see fig. 2)
 Burn to signal failure acc. NAMUR Recommendation NE43 (18.01.1994)
- Operating range** : 3.6 to 21mA
- Communication** : HART®, 1200 Baud, FSK modulated on 4 to 20 mA signal
- Bus connection** : Intrinsic safe EN 50020 according ATEX non incendive EN 50021
- Configuration** : Local with 6 keys
- Software** : Firmware based on Yokogawa stack.
- Hardware** : JSP HART® modem (MH-02)
- Hand terminal** : Rosemount HHT 275
- Other control systems** : Yokogawa PRM, Rosemount AMS, Siemens PDM,
- Output span**
 - pH : min 1 pH, max 20 pH.
 (max 90% zero suppression)
 The instrument is user programmable for linear or non-linear pH ranges.
- Cable specification**
 - Min. cable diameter: 0.51 mm, 24 AWG
 - Max. cable length : 1500 m
 (Detailed information can be found at: www.hartcomm.org)
- DD specification** : The PH202 Device Description is available enabling communications with the Handheld communicator and compatible devices.

PROFIBUS-PA communications:

- Input signal** : Digital
- Supply voltage** : 9 to 32 VDC
- Operating current** : 24.5 mA
- Operating values** : According to IEC 1158-2
- Bus connection** : Fieldbus interface based on IEC 1158-2 according to FISCO-Model
- Power supply** : Power supply is achieved dependant on the application by means of segment coupler
- Data transfer** : According to PROFIBUS- PA profile class B based on EN 50170 and DIN 19245 part 4
- GSD file** : The actual file can be downloaded from www.profibus.com
- Configuration** : Local with 6 keys
- Software** : Firmware based on Siemens DPC31 stack.
- Hardware** : PC- or PCMCIA-interfaces from Siemens)
- Other control systems** : Siemens PDM
- Electrical connection** : Terminals acc. to IEC 1158-2
- Fieldbus-cable-types** : Twisted and shielded two wire cable according to recommendation based on IEC 1158-2
- Cable diameter** : 6 to 12mm (0.24 to 0.47 inch)

FOUNDATION Fieldbus H1 communications:

- Input signal** : Digital
- Supply voltage** : 9 to 32 VDC
- Operating current** : 24.5 mA (base current)
- Operating values** : According to IEC 1158-2
- Bus connection** : Fieldbus interface based on IEC 1158-2 according to FISCO-Model
- Power supply** : Power supply is achieved dependant on the application by means of segment coupler
- Data transfer** : FF Specification Rev. 1.4, Basic device
- Function blocks** : 3xAI, Transducer, Resource
- Files** : Actual file can be downloaded from our homepage
- Configuration** : Local with 6 keys,
- Software** : National Instruments, NI-FBUS configurator
- Hardware** : FBUS-interfaces from National Instruments (AT-FBUS and PCMCIA FBUS)
- Other control systems** : Yokogawa PRM, DMT

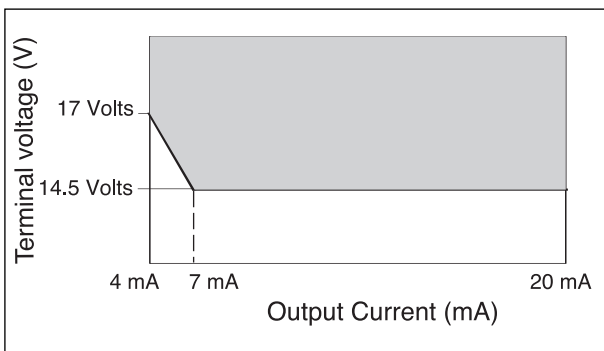

Fig.1 HART® supply voltage/ load diagram

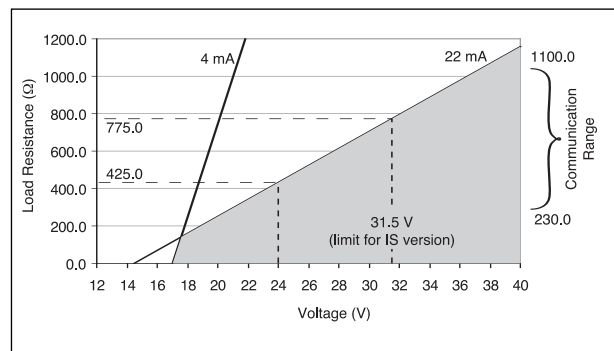

Fig.2 HART® minimum terminal voltage at the PH202

Model	Suffix Code	Option code	Description
PH202G			PH/ORP Transmitter, General Purpose version
Type	- E - C - U - F - P		Milli-amp (+HART®) version, European style Milli-amp (+HART®) version, Canadian style Milli-amp (+HART®) version, North American style FOUNDATION® Fieldbus version Profibus PA version
	- E		Always E
Options		/H /U /SCT /Q	Hood for sun protection Pipe & Wall mounting hardware Stainless steel tagplate Calibration certificate

Model	Suffix Code	Option code	Description
PH202S			PH/ORP Transmitter, Intrinsic Safe version
Type	- E - C - U - F - P - N - B - D		Milli-amp (+HART®) version, European style Milli-amp (+HART®) version, Canadian style, North American style Milli-amp (+HART®) version, North American style FOUNDATION® Fieldbus version Profibus PA version Non-Incendive Milli-amp (+HART®) version Non-Incendive FOUNDATION® Fieldbus version Non-Incendive Profibus PA version
	- E		Always E
Options*		/H /U /SCT	Hood for sun protection Pipe & Wall mounting hardware (SS) Stainless steel tagplate

* /Q: Quality Inspection certificate is always included with the product.

Spare Parts pH202(G)

Part no.	Description
K1500AU	Gland set 1/2 inch for EXA's
K1542KG	/H for EXA200/202 (hood)
K1542KW	/U pipe/wall mounting for EXA (SS)
K1544BK	Eprom + latest software PH202G(S)
K1544FA	Pin-header for HART®-FF interface
K1544ST	/SCT for EXA200/202
K1548FU	Flash-loader kit
MH-02	Sparepart HART® modem

Spare Parts pH202(S)

Part no.	Description
K1500AU	Gland set 1/2 inch for EXA's
K1542KG	/H for EXA200/202 (hood)
K1542KW	/U pipe/wall mounting for EXA
K1544BK	Eprom + latest software PH202G(S)
K1544ST	/SCT for EXA200/202
K1548FU	Flash-loader kit
MH-02	Sparepart HART® modem

Dimensions

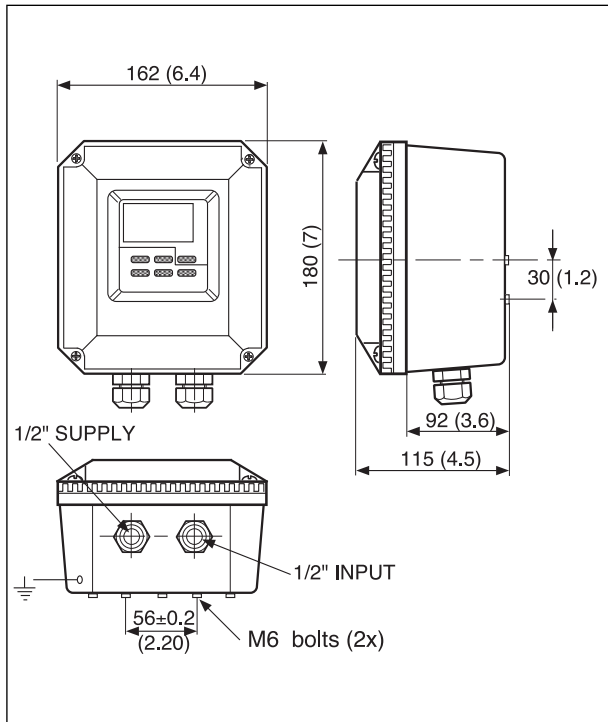

Universal pipe/wall mounting

wDimensions and mounting

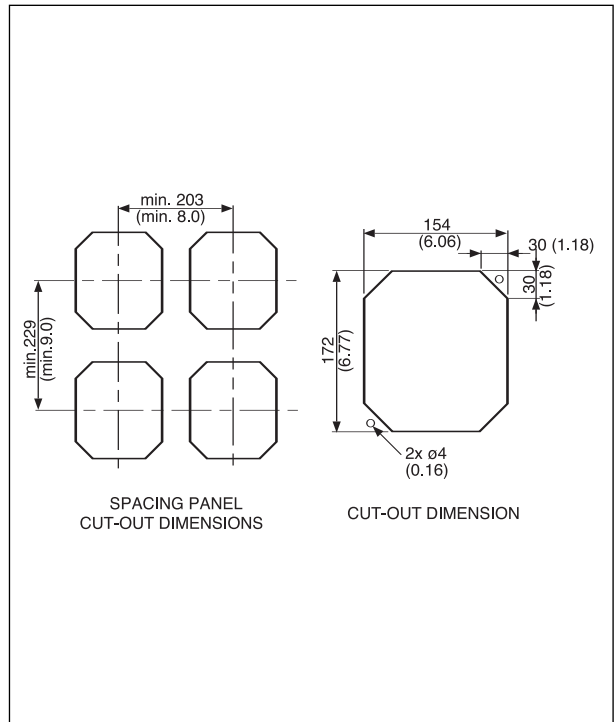

Panel cut-out, spacing and mounting

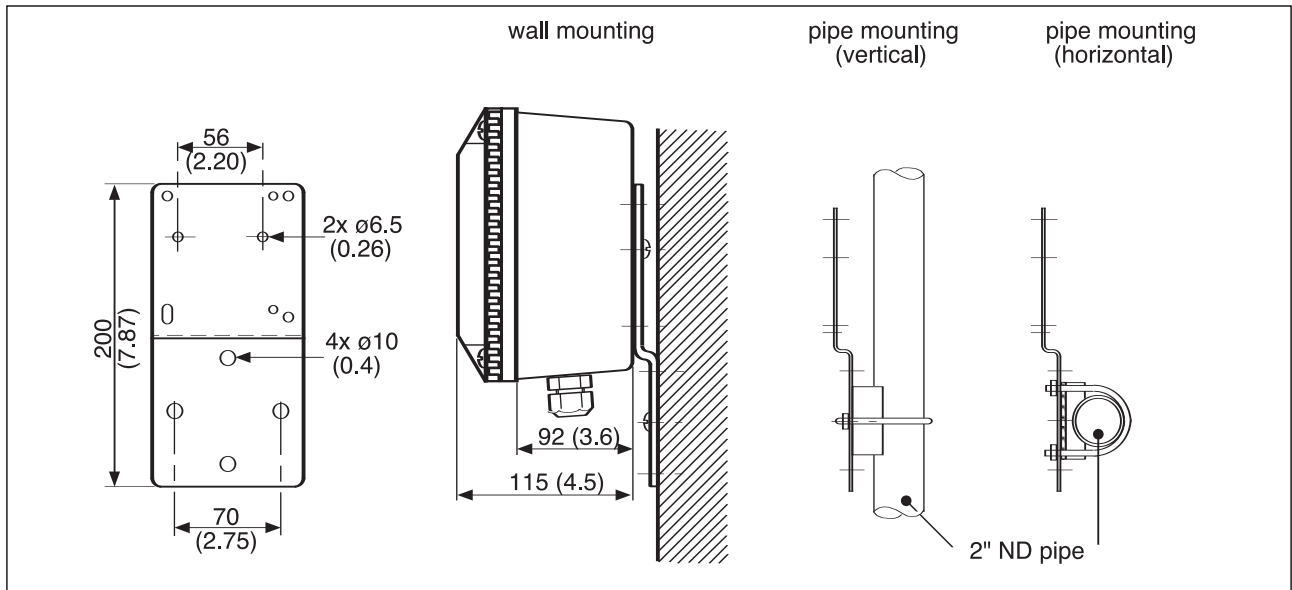

YOKOGAWA HEADQUARTERS
 9-32, Nakacho 2-chome,
 Musashinoshi
 Tokyo 180
 Japan
 Tel. (81)-422-52-5535
 Fax (81)-422-55-1202
 www.yokogawa.com

YOKOGAWA EUROPE B.V.
 Databankweg 20
 3821 AL AMERSFOORT
 The Netherlands
 Tel. +31-33-4641 611
 Fax +31-33-4641 610
 www.yokogawa.com/eu

YOKOGAWA CORPORATION OF AMERICA
 2 Dart Road
 Newnan GA 30265
 United States
 Tel. (1)-770-253-7000
 Fax (1)-770-251-2088
 www.yokogawa.com/us

YOKOGAWA ELECTRIC ASIA Pte. Ltd.
 5 Bedok South Road
 Singapore 469270
 Singapore
 Tel. (65)-241-9933
 Fax (65)-241-2606
 www.yokogawa.com/sg

Yokogawa has an extensive sales and distribution network. Please refer to the European website (www.yokogawa.com/eu) to contact your nearest representative.



YOKOGAWA ◆