

General Specifications

SC24V
4 in 1 differential pH sensor

The SC24V differential pH sensor is unique to the industry, offering maintenance free operation without any reference problems. In the SC24V differential pH sensor, the reference cell is made of glass, with no porous junction, so no electrolyte is in contact with the process.

The differential measuring principle combines the normal potential generated by the pH glass with the potential from a Sodium pNa glass. In applications where Sodium-, Potassium- or Calcium-salt is present the glass will generate a stable reference voltage. This means the measurement can be done, eliminating problems caused by aging and pollution of the liquid junction. Experienced with a conventional reference electrodes.

Because the sensor integrates four functions in one – pH sensing, reference cell, temperature compensation and liquid earth (ORP), there is only one sensor and one cable to deal with. The unit is designed for 12 mm PG13.5 mounting, and is compatible with most industrial holders.



Features

- No reference electrode or junction
- Low maintenance
- No diffusion = high stability

Applications

- Process where KCL is forbidden
- Process with rapid temperature / pressure changes
- Chlorine manufacturing (electrolysis of Brine)
- Bio- ethanol fermentation processes
- Pulp and Paper

System Configuration

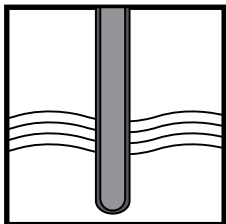

Sensors

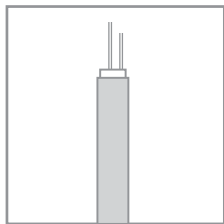

Cables

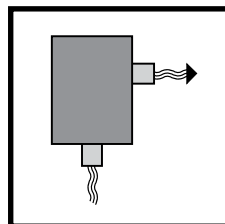

Fittings

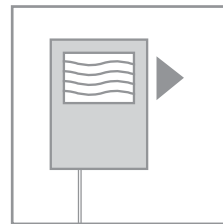

Transmitters

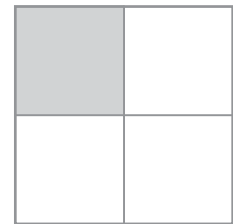

Accessories

General

The SC24V is not a conventional pH sensor. It is a differential sensor that uses two dissimilar ion sensitive glass membranes to generate the pH signal. The measuring element is the same as a conventional pH electrode, and the reference similar to a Sodium ion electrode. Therefore the SC24V can only be used in combination with pH Analyzers that feature:

1. Dual high impedance sensor inputs
2. Adjustable setting for the Isothermal Point
3. Adjustable temperature coefficient

The Yokogawa models PH202 and PH450 satisfy these requirements.

The SC24V differential measuring principle has significant advantages over conventional electrode designs in a variety of difficult applications. The hermetically sealed reference eliminates exposure of the reference fill solution to the process, as there is no reference junction to be affected by aging, plugging or poisoning from the process. This greatly reduces maintenance problems since the reference stability of the differential sensor is then only dependant on the sodium concentration of the process.

The SC24V is ideally suited for difficult applications where conventional electrodes suffer from reference problems, especially when high temperatures and high pressures are involved. Fully, 70 – 80% of industrial users will benefit from using the SC24V, as they will have sufficient sodium levels in their processes for a stable measurement.

The only applications where the SC24V cannot be used are those where the salt concentration is too low, such as pure and ultrapure water processes.

Examples of applications where the sensor has proven to be successful are:

1. Chlorine manufacturing by electrolysis of brine
2. Bio-ethanol fermentation

Calibration

In order to calibrate a differential sensor, all of the buffer solutions must have the same ionic strength because the sodium reference will change as the ionic strength changes. The pH Buffer standards that are preprogrammed in the Analyzer are for conventional pH sensors and have varying ionic strengths.

Therefore, the **AUTOCAL** mode in the analyzer can NOT be used for calibration of the SC24V differential sensor. The sensor must be calibrated using the **MANUAL** method and special buffer solutions:

K1520BG	pH 2.00	(Ionic strength – 1 mol NaCl) (500 ml)
K1520BH	pH 4.00	(Ionic strength – 1 mol NaCl) (500 ml)
K1520BJ	pH 7.00	(Ionic strength – 1 mol NaCl) (500 ml)
K1520BK	pH 9.00	(Ionic strength – 1 mol NaCl) (500 ml)

Standard buffers (4.01; 6.86; 9.18) can be used to *functionally* check sensors, however if they are used for calibration, the Asymmetry and Slope values will be incorrectly calculated.

In that case it is better to use default settings for ASY (0 mV) and SLOPE (100%) and use the buffers only to verify the proper functioning of the sensor.

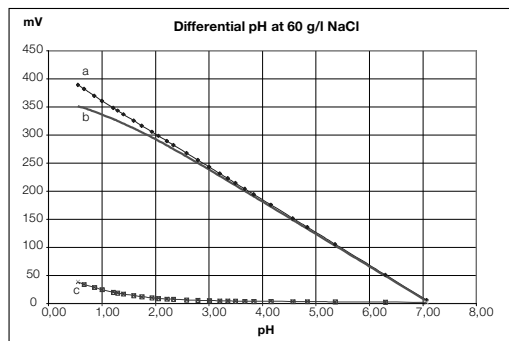

Figure 1

How to read this graph?

This Graph shows that in this application, the sensor behaves like any conventional pH sensor with the Isopotential at 7.00 pH, 0 mV and linear response over the complete pH range down to 2.00 pH. Below 2.00 pH there is a slight non linearity. Between 0.0 and 1.00 pH the sensor sensitivity is too low to get a good measurement.

Functional specifications

Measuring elements

- pH glass electrode
- Silver/Silver Chloride reference
- Solid Platinum electrode
- Pt1000 temperature sensor.

Construction materials / wetted materials:

Earth Pin	: Platinum
Sensor	: Glass

Functional specifications

Glass impedance

pH-glass dome	: 600 to 900 MΩ
pNa-glass dome	: 600 to 900 MΩ

Isothermal point	: pH 7, pNa 0
Reference system	: pNa, salt sensitive reference glass

Temperature element	: Pt1000 to IEC 751
Asymmetry potential	: 0 ± 15 mV
Slope	: > 93 % (of theoretical value)

NOTE: The SC24V temperature sensor is designed for cell compensation and for indication. It is NOT designed for process temperature control.

Dynamic specifications

Response time

pH step (7 to 4)	: < 15 sec for 90%
Temp element ($\Delta 25^{\circ}\text{C}$)	: < 90 sec for 90%

Stabilization time

0.02 pH unit/ 10 sec	: < 2 minutes
----------------------	---------------

Operating range

pH	: 2 to 14
Temperature	: -10 to 120 °C (14 to 248 °F)
Pressure	: 0 to 10 bar (0 to 145 PSIG)
Conductivity	: > 50 $\mu\text{S}/\text{cm}$
Storage temperature	: -10 to 50 °C (14 to 122 °F)
Sodium	: Refer to Figure 1

NOTE: Specifications should not be considered in isolation. Contact your local sales office for application assistance.

Model & Suffix Codes

Model Code	Suffix Code	Option Code	Description
SC24V			Combined 12mm four-in-one salt sensitive reference pH sensor with Variopin connector
Sensor type	-ALN26		Ag/AgCl reference system, pH half cell Hi-temp, reference cell salt sensitive glass, non-flow, heavy duty
Sensor length		-120 -225	120 mm 225 mm

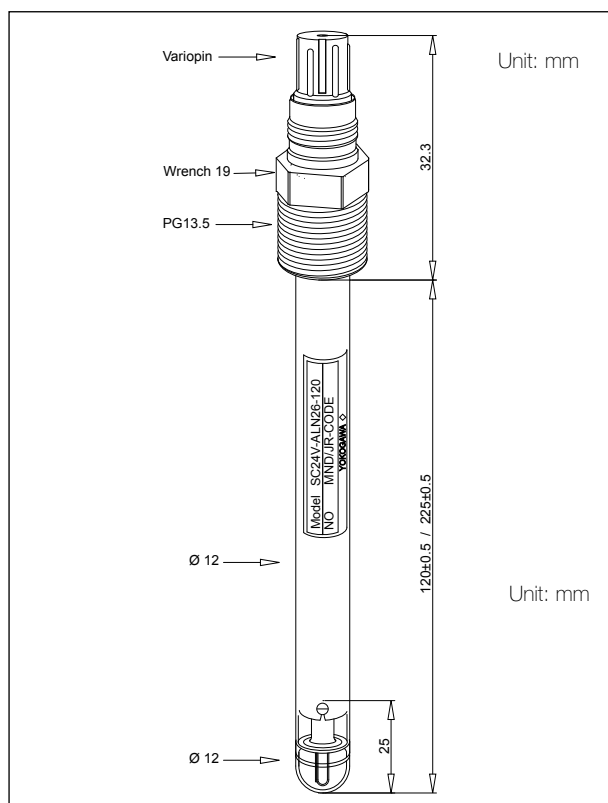

Figure 2 SC24V sensor dimensions

Holders

The 12mm OD design of the SC24V, with PG 13.5 process connection and VP8 cable connection, makes it suitable for installation with the majority of industrial sensor holder assemblies, including many direct insertion versions like the Yokogawa **PR10**.

The 120 mm length version is directly compatible with all of the following Yokogawa holders: **PF20**, **PD20** and **PS20**. It can also be used with the **FF20**, **FS20** and **FD20** holders by using an adapter: **K1520JN** (CPVC); **K1500DV** (PVDF) or **K1520JP** (Stainless Steel), See Figure 3.

If the SC24V is used with the Yokogawa conductivity holders, **FF40**, **FD40** or **FS40**, then the **K1523JA** adapter must be used.

A very compact installation solution, is to use the SC24V with the **K1598AC** mounting tee and a PG.13.5 adapter, **K1523JB**

(Noryl) or **M1263LP** (Stainless Steel) See Figure 6.

Cabling: An 8-pin Variopin connector, with a double coax VP8 cable is used to connect the SC24V to the analyzer. This cable comes in various lengths, the maximum being 20 meters.

WU10-V-D-03	3 meter length
WU10-V-D-05	5 meter length
WU10-V-D-10	10 meter length
WU10-V-D-15	15 meter length
WU10-V-D-20	20 meter length

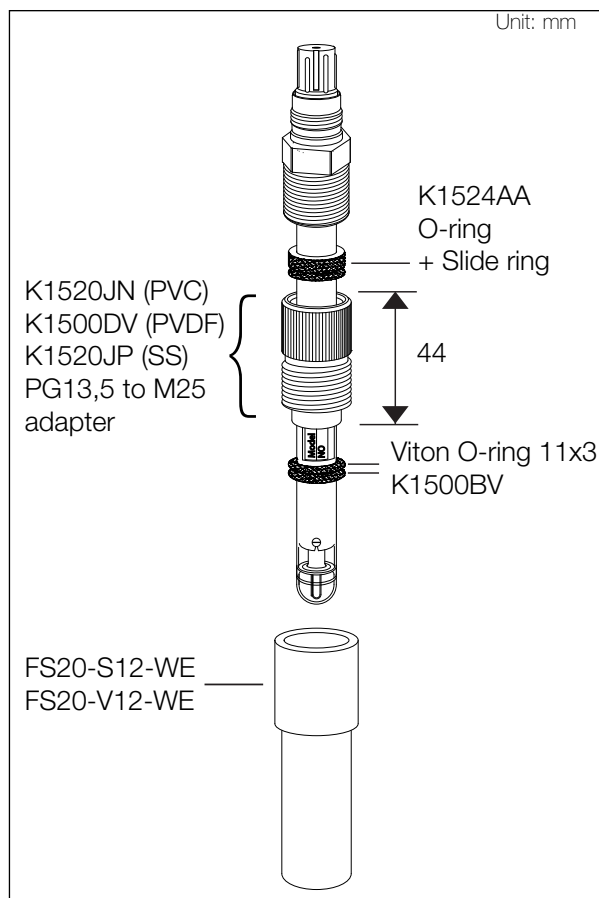

Figure 3 SC24 in a FS20 holder

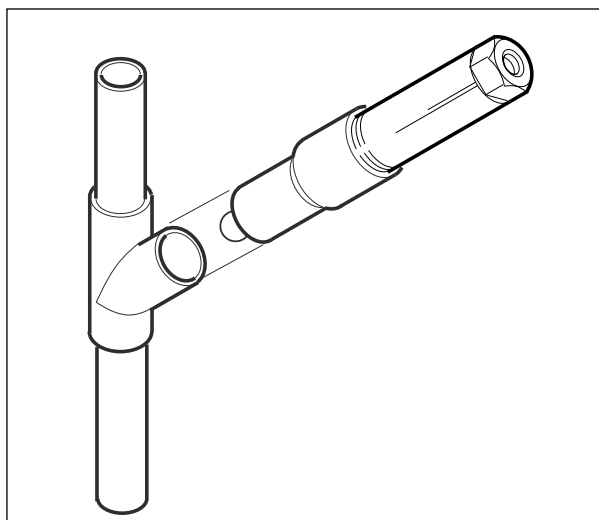

Figure 4 Application examples subassemblies SS/PVC

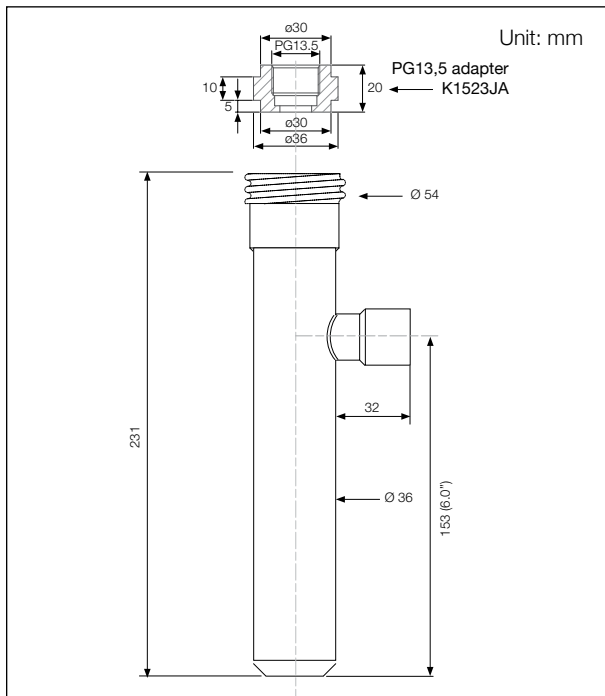

Figure 5 Flow fitting FF40

When the sensor is used in the YOKOGAWA FF40/FD40 or FS40 Conductivity holders, then adapter K1523JA must be specified

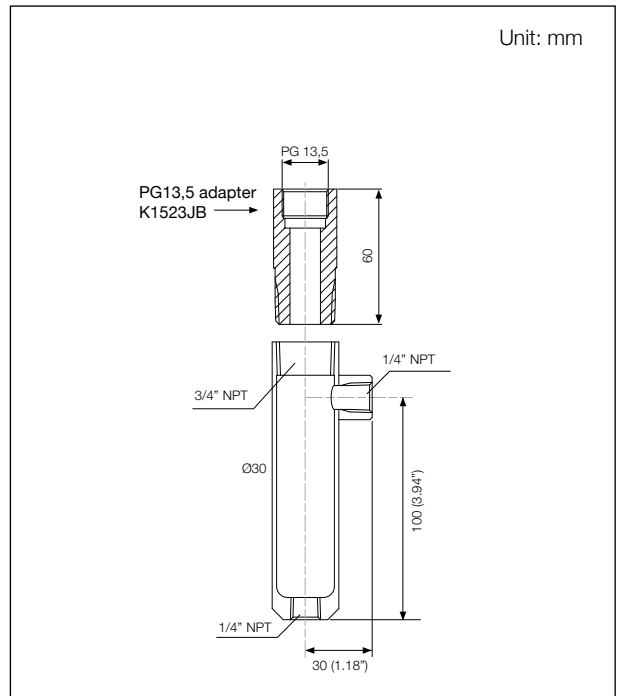

Figure 6 Flow fitting SC4A

Also a very small conductivity flowfitting is available (K1598AC), together with the PG13,5 adapter (K1523JB or M1263LP) for a very compact solution.

Spare parts for SC24V

Buffer solutions

Prod. No.	Description
K1520BG	Buffer Solution PH 2 (Ionic strength - 1 mol NaCl) (500 ml)
K1520BH	Buffer Solution PH 4 (Ionic strength - 1 mol NaCl) (500 ml)
K1520BJ	Buffer Solution PH 7 (Ionic strength - 1 mol NaCl) (500 ml)
K1520BK	Buffer Solution PH 9 (Ionic strength - 1 mol NaCl) (500 ml)
K1520BF	1 mol NaCl buffer solution Kit (PH 4/7/9)

Connection equipment

Prod. No.	Description
WU10-V-D-02	Cable Variopin dual coax 2 m
WU10-V-D-05	Cable Variopin dual coax 5 m
WU10-V-D-10	Cable Variopin dual coax 10 m
WU10-V-D-15	Cable Variopin dual coax 15 m
WU10-V-D-20	Cable Variopin dual coax 20 m
BA10	Junction box for pH extension cables
WF10-XXX-F	pH signal cable with terminated ends. Specify length in whole meters (e.g. XXX = 020)

Sealings

Prod. No.	Description
K1500BV	O-Rings EPDM 11X3 (6 PCS.)
K1500BZ	O-Rings VITON 11X3 (6 PCS.)
K1500GR	O-Rings SILICON 11X3 (8PCS)
K1524AA	O-ring + Slide ring Set

Adapters

Prod. No.	Description
K1523JA	Adapter for mounting Pg13,5-sensors in F*40
K1520JN	Adapter M25x1.5 - PG13.5 PVC
K1520JP	Adapter M25x1.5 - PG13.5 RVS
K1500DV	Adapter M25x1.5 - PG13.5 PVDF
K1523JB	Adapter PG13.5 to 3/4"NPT, Noryl
M1263LP	Adapter PG13.5 to 3/4"NPT, SS316
K1598AC	Flow fitting (3.1), for SC4A (In combination with K1523JB)

Yokogawa Corporation of America

North America
 2 Dart Road, Newnan, GA 30265-1094, USA
 Phone: 800-258-2552 Fax: 770-254-0928

12530 West Airport Blvd., Sugar Land, TX 77478
 Phone: 281-340-3800 Fax: 281-340-3838

Mexico
 Melchor Ocampo 193, Torre C, Oficina 3"B"
 Veronica Anzures D.F., C.P. 11300
 Phone: (55) 5260-0019, (55) 5260-0042

Yokogawa Canada, Inc.
 Bay 4, 11133 40th Street SE, Calgary, AB Canada T2C2Z4
 Phone: 403-258-2681 Fax: 403-258-0182

Yokogawa has an extensive sales and distribution network. Please refer to the website (www.yokogawa.com/us) to contact your nearest representative.



YOKOGAWA ◆