

TABLE OF CONTENTS

1. INTRODUCTION	3
1-1. General.....	3
1-2. Cleaning system	3
1-3. Selection criteria	3
1-4. Compatibility.....	4
1-5. Warranty and service.....	4
2. SPECIFICATIONS	5
2-1. Brush cleaning	5
2-2. Chemical cleaning	6
2-3. Models and suffix codes.....	6
3. DESCRIPTION	7
3-1. Brush cleaning system	7
3-1-1. General	7
3-1-2. Driving mechanism (electric)	7
3-1-3. Driving mechanism (pneumatic)	7
4. INSTALLATION	8
4-1. Unpacking and checking	8
4-2. Installation site	8
4-3. Brush cleaning	9
4-3-1. Brush holder	9
4-3-2. Driving mechanism (electric).....	9
4-3-3. Wiring the driving mechanism (electric).....	10
4-3-4. Driving mechanism (pneumatic).....	10
4-3-5. Control unit for driving mechanism (pneumatic)	10
4-3-6. Connecting control and driving mechanism (pneumatic)	11
4-4. Chemical cleaning	11
4-4-1. Spray unit.....	11
4-4-2. Connecting the spray unit	11
5. ADJUSTMENTS	12
5-1. Brush cleaning	12
5-1-1. Brush adjustments	12
5-1-2. Driving mechanism (pneumatic).....	12
6. DIMENSIONS	13
6-1. Spare parts list	15
7. INSTALLATION OF CHEMICAL CLEANING SYSTEMS HCN 2/3/4/F	16

1. INTRODUCTION

1-1. General

For industrial applications and particularly for automatic process measurements, it is of the greatest importance that the sensitive part of a glass electrode and the flow diaphragm of a reference electrode are kept clean. Often it is not practical to interrupt a process for cleaning the electrodes, an accurate indication is required over a long period, replacing the electrodes is difficult, etc.

There, an automatic cleaning mechanism may be the solution.

YOKOGAWA manufactures two different cleaning systems for pH and/or ORP (Redox) measurements:

- chemical cleaning
- brush cleaning
 - a. pneumatically driven
 - b. electrically driven

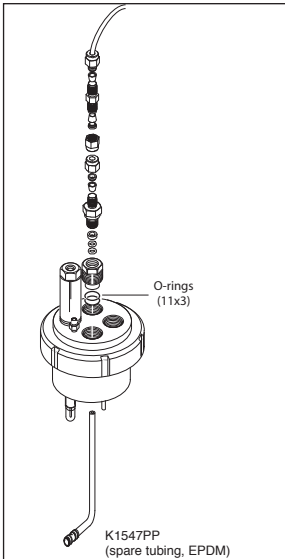

Fig. 1 Brush Cleaning (pneumatically driven)

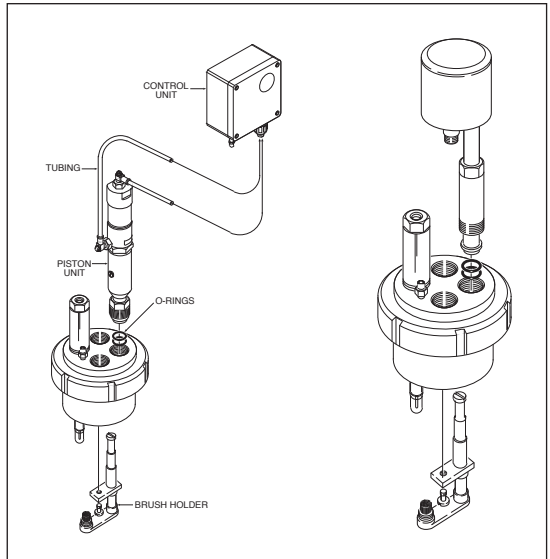

Fig. 2 Brush Cleaning (electrical driven)

1-2. Cleaning systems

The cleaning elements have standardised dimensions for mounting in flow and/or

immersion fittings. These fittings have the following model codes:

Model	Type	Material
FF20-P43	Flow fitting	Polypropylene
FF20-F43	Flow fitting	Polyvinylidene fluoride
FF20-S43	Flow fitting	Stainless steel
FD20-P47	Immersion fitting	Polypropylene
FD20-F47	Immersion fitting	Polyvinylidene fluoride
FD20-S47	Immersion fitting	Stainless steel
FS20-V42	Subassembly flow fitting	PVC
FS20-S43	Subassembly flow fitting	Stainless steel

Detailed specifications of the fittings are on separate sheets (see GS 12B6K1 and GS 12B6K2)

1-3. Selection criteria

The table below indicates the recommended cleaning method for your specific application.

Selection criteria

Applications with:	Mechanical	Chemical	
	Brush	Acid	Base
Oils, fats			
Resins (wood, pulp)			X
Emulsions of latex	X		
Fibers (paper, textile)	X		
Crystalline precipitations (carbonates)	X	XX	
Amorpheus precipations (hydroxides)	X	XX	

1-4. Compatibility

The Yokogawa analysers model number PH402 and PH450 is equipped with a wash timer function to control the chemical cleaning system. Detailed information is given on sheet and GS 12B6B3-E-E (PH402) and GS 12B6B5-E-E (PH450).

1-5. Warranty and service

Products and parts are warranted to be free from defects in workmanship and material under normal use and service for a period of typically twelve months from the date of shipment by manufacturer. The sales organisation has the possibility to deviate from this typical warranty period and the actual terms and conditions as specified in the sales order must be consulted. Damages, caused by wear and tear, inadequate maintenance, corrosion and attack by chemical processes are excluded from this warranty coverage.

Any defective goods need to be sent to the service of the sales organisation for repair or replacement and the returned material should be accompanied by a letter of transmittal, which should include the following information:

1. Part number, model code and serial number
2. Date and number of sales order

3. Length of time of service and type of service
4. Description of the faulty operation of the device and the circumstances of the failure
5. Pressure, temperature, process compensation and all other process conditions or environmental circumstances which are related to the installation and possibly failure of the device
6. Statement as to whether warranty or non-warranty service is requested
7. Complete shipping and billing instructions for return of material and name, phone number of contact person that can be approached for further information.

The returned goods that have been in contact with process fluids must be detoxified and disinfected prior to shipment for the health and safety of our employees. Material Safety Data sheets must be included for all components of the processes in which the cleaning system has been used.

The shipping address where the goods have been returned is specified on the original sales order or on the back page of this manual.

2. SPECIFICATIONS

2-1. Brush cleaning

Brush holder

Material	
- Body	: a. Stainless steel b. Epoxy c. Silicone rubber d. Epoxy resin
- Brush	: Horse hair (in PVDF holder)
Process conditions	: Max. 1 MPa (10 bar) at 100 °C
Weight	: Approx. 120 g
Mounting	: In Yokogawa flow or immersion fittings (4-hole)

Driving mechanism (electrical)

Supply (see note)

- Voltage	: 24 V AC (± 10 %)
- Frequency	: 50/60 Hz
- Consumption	: Max. 4 VA

Cleaning frequency : 2 strokes per minute

Angle : Rotation of 40 ° (swing)

Electrical connection

- Connector	: Gold plated spring O-connector (for standard Yokogawa electrode cable Model WU20-PC□□)
- Screw thread	: 1/4" BSPP

Material

- Driving system	: Stainless steel AISI 316
- Driving shaft	: Stainless steel AISI 316
- Cap	: Silicone rubber
- Connector holder	: Polyvinylidene fluoride (PVDF)
- Mounting nut	: Ryton R4
Weight	: Approx. 1 kg

Driving Mechanism (pneumatic)

Piston unit

Air supply	: Adjustable (via the connected control unit)
Cleaning frequency	: 1/4.... 2 strokes per minute (adjustable on the control unit)
Angle	: Rotation 40°
Air connectors	: ø4 mm (external) (IN1 and IN2)
Material	
- Body	: Brass
- Mounting gland	: Stainless steel AISI 316
Weight	: Approx. 1 kg

Control unit

Air supply : 140 kPa (1,4 bar) pressurised air

Ambient temp. range : -10 to 60 °C

Housing

- Material	: Aluminium case with chemical resistant lacquer (IP65)
- Entries	: Air connector ø6 mm
- Dimensions	: See dimensional drawings
- Mounting	: Wall mounting (for fixing dimensions, see dimensional drawings)
- Weight	: Approx. 2,5 kg

Supply (see note)

- Voltage : 24 V AC (\pm 10 %)
- Frequency : 50/60 Hz
- Consumption : Max. 4 VA

Cleaning frequency : 2 strokes per minute

Angle : Rotation of 40° (swing)

Electrical connection

- Connector : Gold plated spring O-connector (for standard Yokogawa electrode cable, Model WU20)
- Screw thread : 1/4" BSPP

Material

- Driving system : Stainless steel AISI 316
- Driving shaft : Stainless steel AISI 316
- Cap : Silicone rubber
- Connector holder : Polyvinylidene fluoride (PVDF)
- Mounting nut : Ryton R4

Weight : Approx. 1 kg

2-3. Chemical cleaning system**Features**

- The EXA pH450 analyser has a built-in timer and HOLD circuit.
- Built-in (no return) nozzle to prevent penetration of the process liquid into the cleaning system.

Materials

- Nozzle : Hastelloy
- O-rings : EPDM rubber
- Mounting set : Stainless steel
- Tubing : 1/4" (OD \varnothing) Nylon tubing
- Process cond. : Max. 1 MPa (10 bar) at 100 °C

Mounting

- K1547PA : /HCN2, 2-hole flow-, insertion fitting (PH20)
- K1547PA : /HCN3, 3-hole flow-, insertion-, immersion fitting
- K1547PB : /HCN4, 4-hole flow-, insertion-, immersion fitting
- K1547PJ : /HCNF, back-end mounting on FU20/PH20

2-4. Model- and suffix codes**Mechanical cleaning system**

Model	Suffix code	Options code	Description
FC20			Cleaning system
Design	-VE		Brush cleaning (electrical driven)
	-VP		Brush cleaning (pneumactical driven)
Options		/T	10 mtr. nylon tubing 6.35 mm OD (1/4")

Spareparts Chemical cleaning system

Type	Description
K1547PA	Complete cleaning system HCN2, HCN3
K1547PB	Complete cleaning system HCN4
K1547PJ	Complete cleaning system HCNF for back-end mounting on FU20/PH20
K1547PP	EPDM spraying valve HCNX nozzle (5 sets)

3. Description

3-1. Brush cleaning system

3-1-1. General

The brush in this cleaning system periodically strikes along the sensitive membrane of the measuring electrode, so that this part is wiped frequently, preventing sediment formation on it.

The flow of measuring solution is not obstructed and interruption of measurement during cleaning is not necessary.

The brush cleaning system is activated electrically or pneumatically.

The standardised dimensions allow mounting in the (4-hole) flow- and immersion fittings of Yokogawa.

3-1-2. Driving mechanism (electrical)

The motor of this driving mechanism turns the shaft of the brush holder at 2 strokes per minute through an angle of 40°.

The motor is powered by a 24 V AC voltage. For connecting to this power the motor device is equipped with a gold plated O-connector for use with the standard Yokogawa cable (Model WU20-PC□□).

As a supply unit the Model BC10 of Yokogawa is recommended. In this unit the power of 110 or 220 V AC is transformed to 24 V AC.

ATTENTION:

The electrically driven brush cleaning system may NOT be used in a classified area where explosion hazards are present.

3-1-3. Driving mechanism (pneumatic)

The driver (piston unit) of this type of cleaning mechanism is driven by a control unit in which the cleaning frequency can be adjusted between 1/4 and 2 strokes per minute with a rotating angle of 40°.

The piston unit is powered by instrument air (140 kPa). The interconnection between piston and control unit is made by air tubing which is connected to quick-disconnect couplings on the air cylinder of the piston at one side and on the outputs in the control unit at the other side.

The air tubes can be protected by a hose kit which can be ordered with the fittings (option /PH5 and /PH10).

4. INSTALLATION

4-1. Unpacking and checking

When you receive a cleaning system, it is packed in a cardboard box. Carefully inspect the package for any evidence of damage. If you find any damage, notify the shipping agent and inform the Yokogawa sales organisation immediately.

Open the box and check that the model code is the same as indicated on the sales order. Check that all items are available conform the packing list. If you have any problems or questions, please contact the nearest Yokogawa service center or sales organisation for assistance.

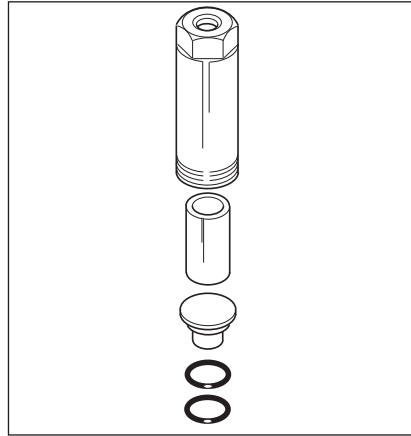

Fig. 3 Blind plug

4-2. Installation site

The Yokogawa fittings have Ryton mounting sets with blind plugs. On each blind plug set two O-rings for water tight sealing (see fig. 3).

In the bottom side of the electrode holder is a threaded hole (M8) for fixing the cleaning assembly.

The dimensions of all cleaning systems are adapted for fixing in a standard electrode mounting hole.

The dimensions (min.) of a vessel are the same for all cleaning systems (see fig. 4) Fig. 5 indicates the distances between the four (4) electrode mounting holes and the earth pin (circular construction). The distance between an electrode hole and a hole for a cleaning system is shown in fig. 6.

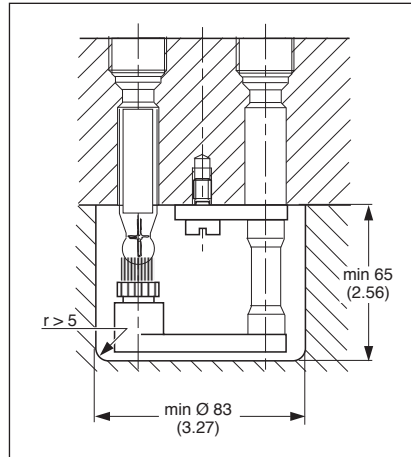

Fig. 4 Dimensions cleaning systems

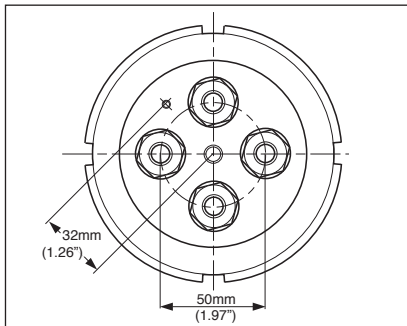

Fig. 5 Dimensions electrode holder

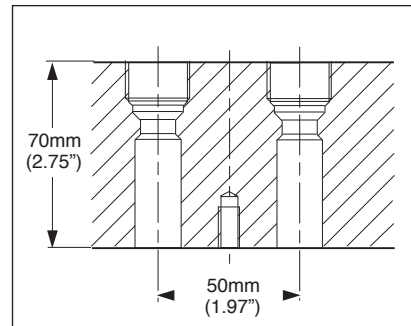

Fig. 6 Dimensions

4-3. Brush cleaning

4-3-1. Brush holder

Remove the electrode mounting set opposite the electrode to be cleaned. Insert the cleaning assembly from the process side upward through this mounting hole and fix it using the supplied M8 screw (see fig. 7).

Slide the 2 O-rings over the shaft of the transducer and seal it with the mounting nut from the driver mechanism. Handtight is tight enough!

After mounting the cleaning assembly the electrode to be cleaned must be mounted in the electrode holder of the fitting according to the mounting instructions (see instruction manual of the fitting). After mounting the electrode the brush height must be adjusted (see chapter 5).

ATTENTION

To have optimal cleaning effects the brush wipes the lower side of the membrane.

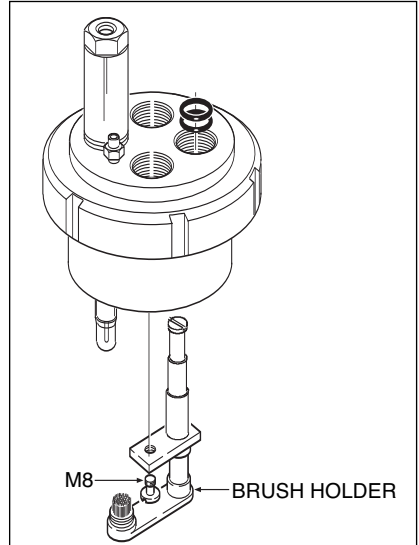

Fig. 7 Brush Holder

4-3-2. Driving mechanism (electrical)

After mounting the brush holder the driving mechanism can be placed on top (see fig. 8). The top of the brush holder is provided with a groove for the driver of the mechanism.

WARNING:

The mechanical cleaner is a slowly moving mechanism. Do not operate the unit while performing maintenance to the electrodes. The cleaner may bruise your finger easily when caught between electrode and wiper arm.

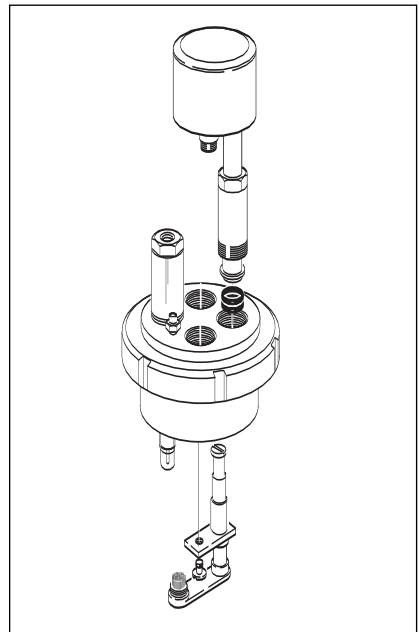

Fig. 8 Driving Mechanism electrical

4-3-3. Wiring the driving mechanism (electrical)

This driving mechanism is provided with a coaxial connector that is similar to the connector of the Yokogawa electrodes. Therefore a standard coaxial cable (Model WU20-PC□□) can be used to power the motor of the driving mechanism from a 24 V AC power supply.

Length of the cable: 1, 2, 5, 10, 15, 20 or 25 m. If a 24 V AC power is not available, the Yokogawa connection box (Model BC10) can be used. In this connection box the power of 110/220 V AC is transformed to 24 V AC. As delivered, the unit is adjusted for connection to 220 V AC, but can be rewired to 110 V AC supply easily. Markings on the transformer indicate the proper wiring (see fig. 9).

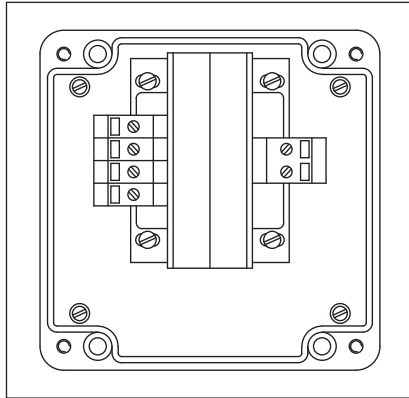

Fig. 9 Wiring driving mechanism

4-3-4. Driving mechanism (pneumatical)

After mounting the brush holder this driving mechanism can be placed on top (see fig. 10). The top of the brush holder is provided with a groove for the driver of the mechanism.

WARNING:

The mechanical cleaner is a slowly moving mechanism. Do not operate the unit while performing maintenance to the electrodes. The cleaner may bruise your finger easily when caught between electrode and wiper arm.

4-3-5. Control unit for driving mechanism (pneumatical)

This control unit has 4 mounting holes (see dimensional drawings on page 11) for wall/surface mounting. The unit is powered by 140 kPa instrument air via the compression fitting for 6 mm OD air tubing.

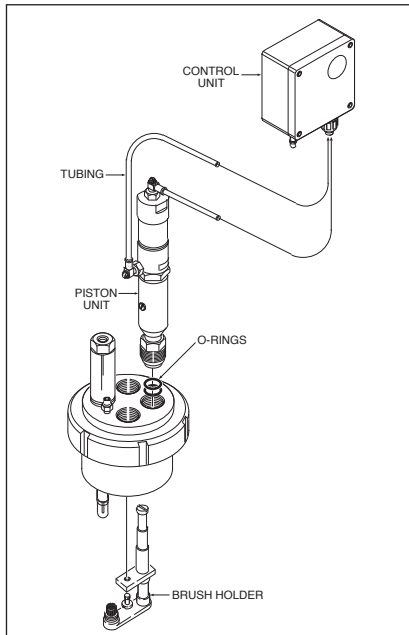

Fig. 10 Driving Mechanism pneumatical

4-3-6. Connecting control and driving mechanism (pneumatic)

A length of 20 m air tubing (OD 4 mm) is provided with the cleaning assembly. This tubing can be connected to the quick disconnect couplings of the air cylinder and to the tube connections OUTPUT in the control unit.

When the cleaning device is used in an immersion fitting the tubes can be lead through a protection hose (Option). This tube is connected to the hose connection of the control unit.

The tube set can be ordered as option /PH5 or /PH10 with the immersion fittings.

4-4. Chemical cleaning

4-4-1. Spray unit

Remove the electrode mounting set opposite the electrode to be cleaned. Insert the cleaning assembly from the process side upward through this mounting hole (see fig. 11). Slide the 2 O-rings over the shaft of the spray unit and seal it with the mounting nut. Handtight is tight enough! This jet spray cleaner needs to be connected to a solenoid that controls water or air supply to the jet. Often a metering pump is used for sensor cleaning. These components are supplied by the user.

4-4-2. Connecting the spray unit

On top of the spray unit is a gland for fixing the nylon tubing. This tubing can be ordered as a sparepart:

K1520FJ tubing set 5 m.

K1520FK tubing set 10 m.

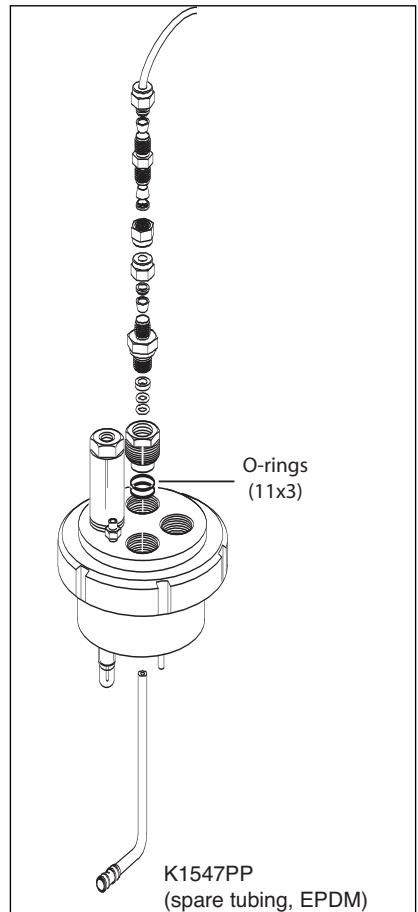

Fig. 11

5. ADJUSTMENTS

5-1. Brush cleaning

5-1-1. Brush adjustment

After mounting the brush holder in the fitting, the electrode to be cleaned must be mounted in the holder (see chapter 3-1-2.). The height of the brush can be adjusted by turning it clockwise (away from the electrode to be cleaned) or anti-clockwise (towards the electrode) to achieve the maximum cleaning effect.

If the brush is mounted too high, the brush and drive will suffer from excessive wear and tear. In optimal situation the brush wipes the under side of the membrane.

5-1-2. Driving mechanism (pneumatic)

The cleaning cycle can be adjusted in the control unit using the adjustment screws marked with 1/5 and 2/4. The screw marked with 1/5 is used to adjust the length of time in "up" position (T1 see fig. 13) and the one marked with 2/4 is used to adjust the length of time in "down" position (T2 see fig. 13). Both periods are adjusted to 30 seconds and the adjustment screws are sealed.

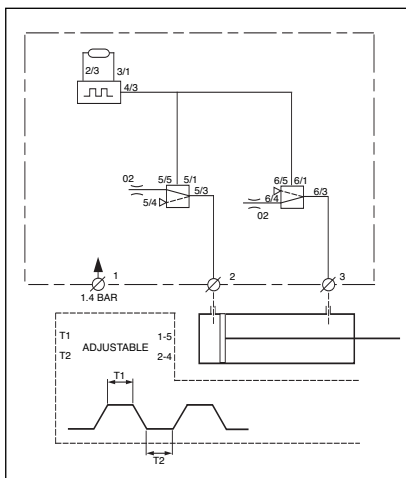

Fig. 12

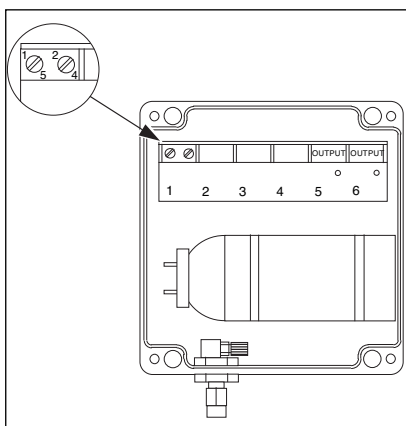

Fig. 13

6. DIMENSIONS

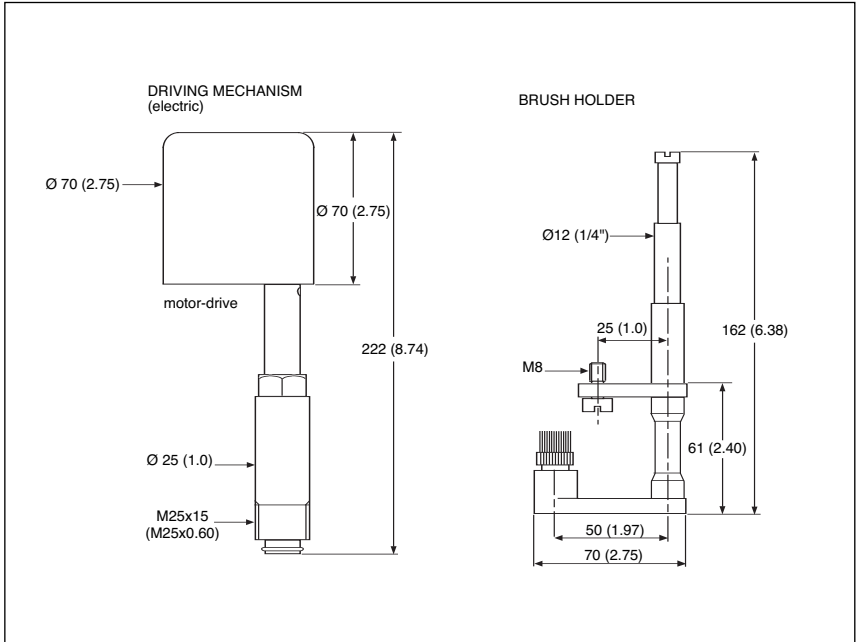

Fig. 14 Brush cleaning

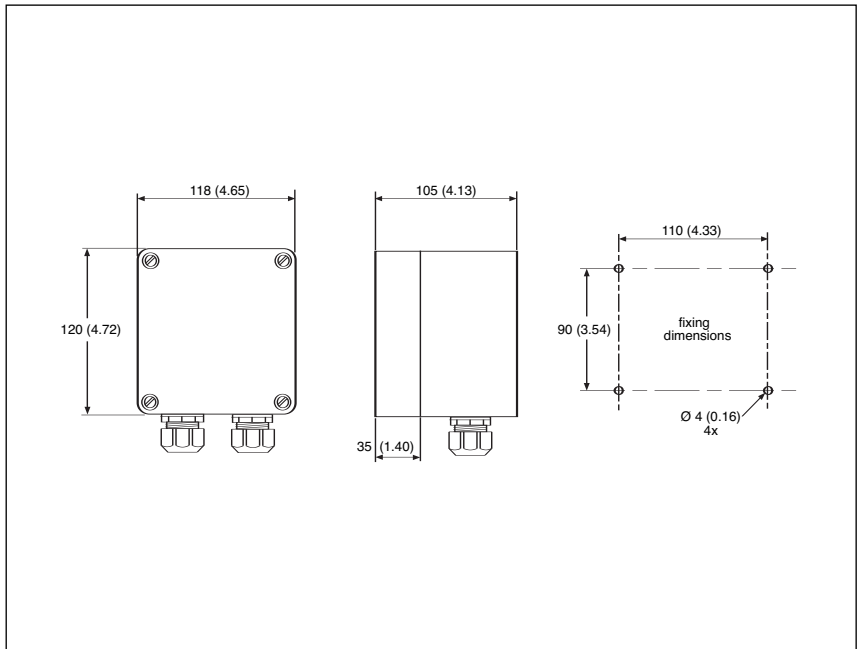

Fig. 15 Supply unit, Type BC10 (option)

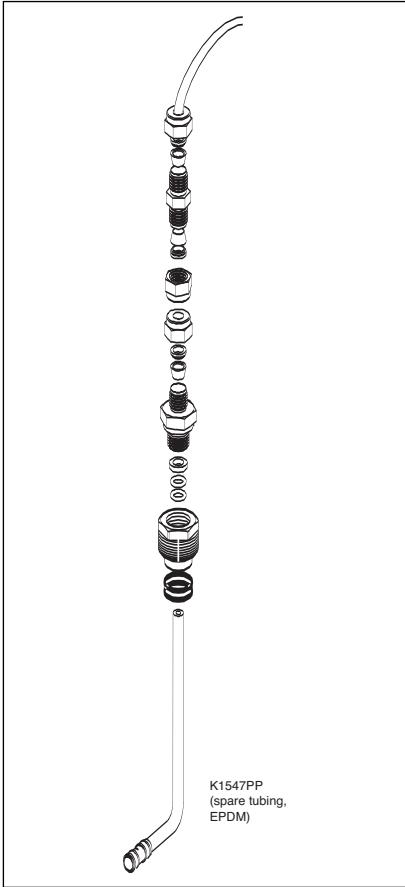

Fig. 16 Chemical cleaning

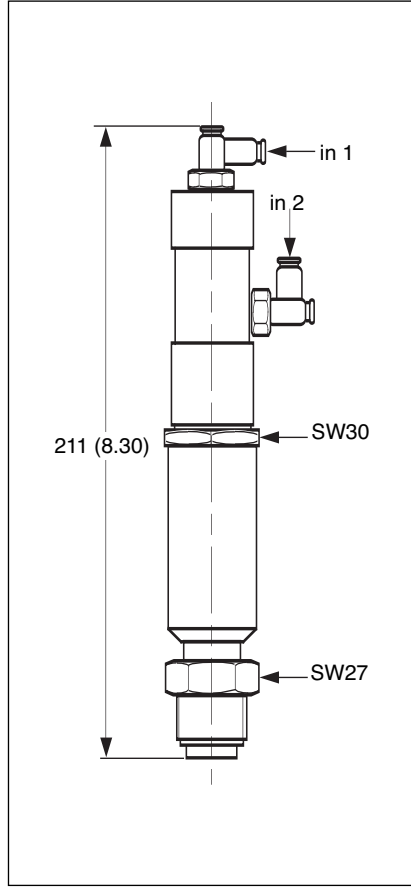

Fig.17 Driving mechanism (pneumatic)

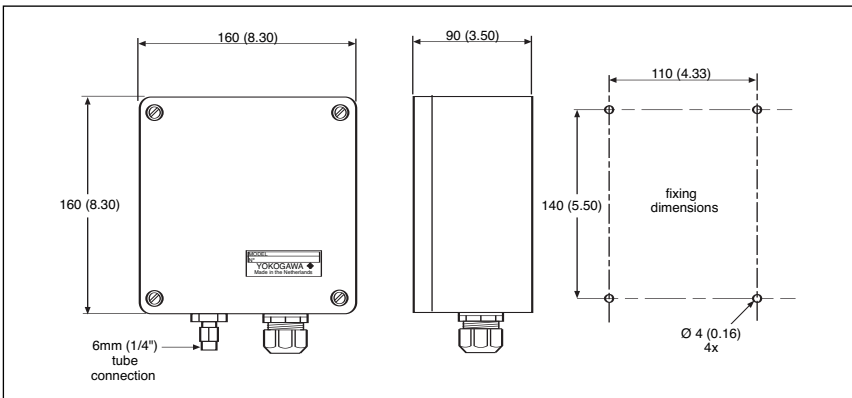

Fig. 18 Control unit (pneumatic)

Chemical cleaning system

Type	Description
K1520FJ	5m tubing
K1520FK	10m tubing
K1547PA	Complete cleaning system HCN2, HCN3
K1547PB	Complete cleaning system HCN4
K1547PJ	Complete cleaning system HCNF for back-end mounting on FU20/PH20
K1547PP	EPDM spraying valve HCNX nozzle (5 sets)

Service parts

Type	Description
K1500BZ	O-rings Viton 11x3 (6Pcs)
K1520NA	Tubing (ø 4 mm) Brush cleaning (pneumatically driven)
K1500GR	O-ring (11 x 3) for mounting in electrode holes (8 pieces)
FP20-R12	Electrode mounting set (Ryton R4) for mounting electrode holes
K1520NB	Brush for mechanical cleaning
K1520NF	Motor unit for electrically driven brush cleaning
K1520NG	Brush holder for mechanical cleaning
K1520NH	Piston for pneumatically driven brush cleaning
K1520NJ	Control unit for pneumatically driven brush cleaning
K1547PF	Nozzle and mounting set HCN2, HCN3, HCNF
K1547PG	Nozzle and mounting set HCN4
K1547PH	Nylon tube (10 mtr) and tube mounting set for hastelloy cleaning system

Accessories and options

Type	Description
WU20-PC02	COAX-cable (2 m) for FC20-VE
WU20-PC05	COAX-cable (5,5 m) for FC20-VE
WU20-PC10	COAX-cable (10 m) for and FC20-VE
BC10	Supply unit (220/24 V AC) for motor of FC20-VE

7. INSTALLATION OF CHEMICAL CLEANING SYSTEMS HCN 2/3/4/F

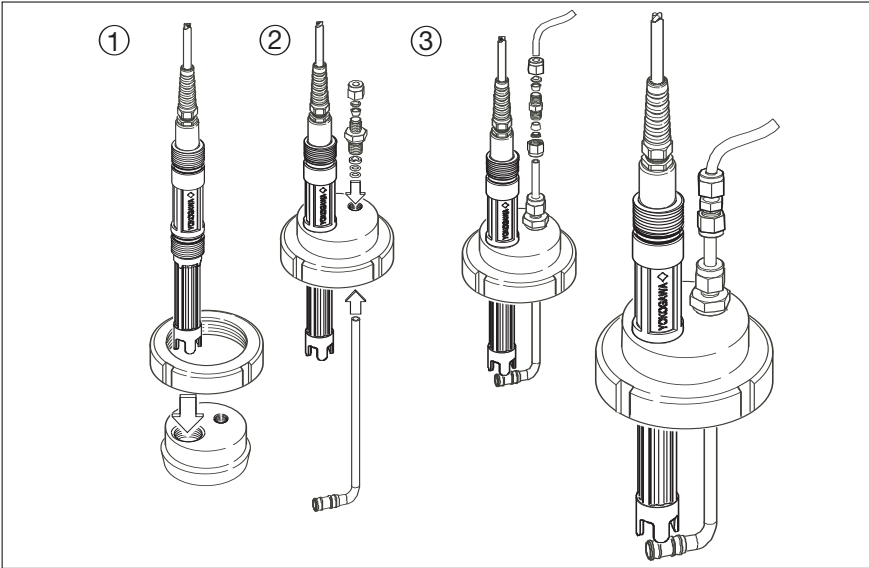

Fig. 19/ HCN2 drawing

Model	Suffix Code	Option Code	Description
FF20			Flow fitting
Material	-P -S -F		Polypropylene (PP) Stainless steel AISI 316 (SS) Polyvinylidene fluoride (PVDF)
Number of holes	22 33 43		For PH20 3 electrode mounting holes 4 electrode mounting holes
		*B	Style code B
Options -Cleaning system		/HCN2 /HCN3 /HCN4	FF20- .22 FF20- .33 FF20- .43
Options -Mounting kit		/B /D /R	For mounting Bellomatic reference electrodes and combined electrodes. For mounting a combined electrode of type SC21-AAC54. For mounting (top) refillable electrodes with long glass shaft.
-Flange adapters (NPT 1/2" male lap joint)		/FP1 /FP2 /FP3 /FP4 /FF1 /FF2 /FF3 /FF4 /FS1 /FS2 /FS3 /FS4	DN15-PN10 PP DN25-PN10 PP 1/2" 150 lbs PP 1" 150 lbs PP DN15-PN10 PVDF DN25-PN10 PVDF 1/2" 150 lbs PVDF 1" 150 lbs PVDF DN15-PN10 SS 316 DN25-PN10 SS 316 1/2" 150 lbs SS 316 1" 150 lbs SS 316
-KCl-reservoir		/K	Electrolyte tubing (2.5 m) is included.
-Salt bridge		/S	For liquid which cannot stand contamination with KCl.
-Certificate		/M	Material certificate 3.1B according to EN-10-204 (DIN 50-049) only for Stainless Steel wetted parts

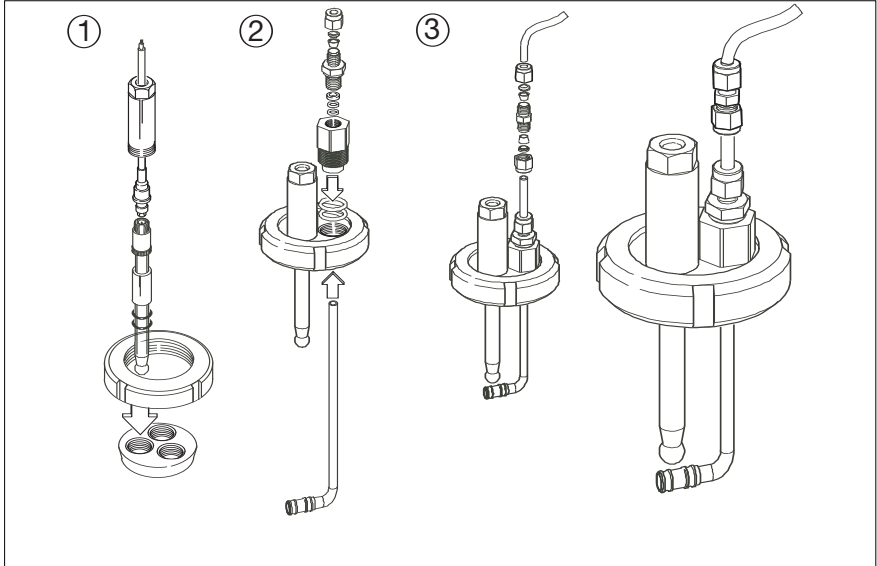

Fig. 20 /HCN3 /HCN4 drawing

Model	Suffix Code	Option Code	Description
FS20			Subassembly (Flow fitting)
Material	-V -P -S -F		Polyvinylchloride (PVC) Polypropylene (PP) Stainless steel AISI 316 (SS) Polyvinylidene fluoride (PVDF)
Number of holes	12 22 32 43		1 electrode mounting holes (only V,S) For PH20 3 electrode mounting holes 4 electrode mounting holes (only V,S)
Mounting	-WE -TP		Welding end: Type, S12, S22,S32, S43 Glue for PVC: Type V12, V22, V32, V43 Heat welding: Type F22, F32, P22, P32 Tapered pipe thread (2"NPT acc. ANSI B.20.1). (for 2 and 3 holes version, and not in case of type V22 and V32)
Options -Cleaning system		/HCN2 /HCN3 /HCN4	FS20- .22 FS20- .32 FS20- .43
Options -Mounting kit		/B /D /R	For mounting Bellomatic reference electrodes and combined electrodes. For mounting a combined electrode of type SC21-AAC54. For mounting (top) refillable electrodes with long glass shaft.
-KCl-reservoir		/K	Electrolyte tubing (2.5 m) is included.
-Salt bridge		/S	For liquid which cannot stand contamination with KCl.
-Certificate		/M	Material certificate 3.1B according to EN-10-204 (DIN 50-049) only for Stainless Steel wetted parts

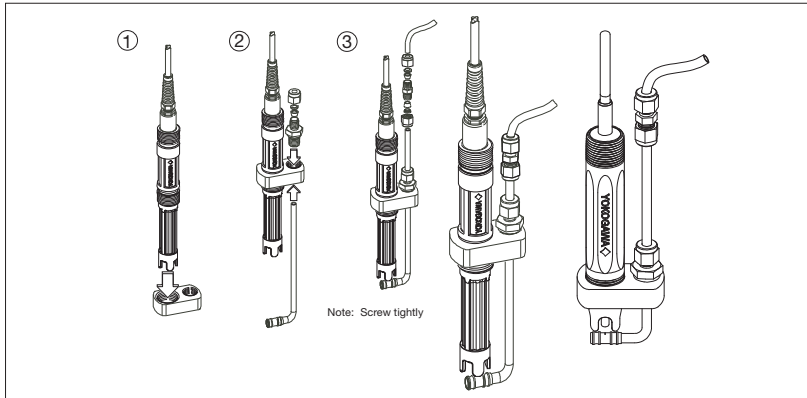

Fig. 21 drawing /HCNF

Model and Suffix codes

Model Code	Suffix Code	Option	Description
PH20			4-in-1 pH sensor
Material	-F		PVDF
Membrane	-G		Dome shaped
Cable length	-02		2 m
	-05		5 m
	-10		10 m
	-20		20 m
	-30		30 m
Temp. element	-T1		Pt1000
	-N -A		Always -N -A
Options		/SN3	Stainless steel 3/4" NPT adapter (316L)
		/SR3	Stainless steel 3/4" R adapter (316L)
		/FN4	PVDF 1" NPT adapter
		/FR4	PVDF 1" R adapter
		/PH8	Adapter for PH8 combi sensor fittings (only)
		/SF4	Stainless steel adapter for FF40, FS40 and FD40 fittings
		/HCNF	Hastelloy cleaning system

Model Code	Suffix Code	Option	Description
FU20			Wide body sensor
Cable length	-03		3 m
	-05		5 m
	-10		10 m
	-20		20 m
	-VP		Variopin
Temp. element	-T1		Pt1000
	-T2		Pt100
Model	-NPT		Dome shape model
	-FSM		Flat surface model
Options		/Q	Quality Inspection Certificate
		/HCNF	Hastelloy cleaning system
		/FPS	Adapter F*40 from noryl
		/NSS	1" NPT adapter, SS (316L)
		/NTI	1" NPT adapter, Titanium
		/BSS	1" BSP adapter, SS (316L)
		/BTI	1" BSP adapter, Titanium

Installation notes for a pump

Tubing: Tubing dimensions are $\text{Ø}6 \times 4$ (o Ø .x i Ø connection size) hard tubing

Cleaning fluid: 5% Hydro Chloric acid is recommended for most applications

Pump selection: Aim for big stroke volume (maximise ml/stroke) Siphoning must be avoided by using a one way valve and/or a pressure regulator.

Example:

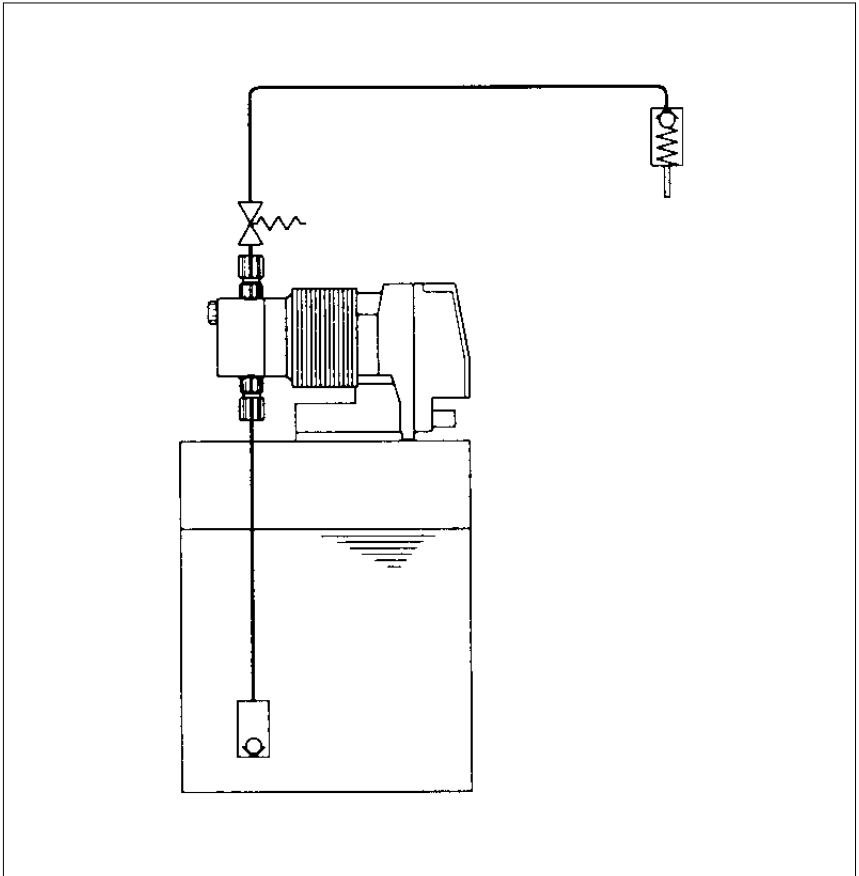

Fig. 22

Any pump that meets the requirements will do. Prominent has a selection of **Solenoid Diaphragm Dosing Pumps (gamma/ L)**

YOKOGAWA ELECTRIC CORPORATION

World Headquarters
9-32, Nakacho 2-chome, Musashino-shi
Tokyo 180-8750
Japan
www.yokogawa.com

YOKOGAWA CORPORATION OF AMERICA

2 Dart Road
Newnan GA 30265
USA
www.yokogawa.com/us

YOKOGAWA EUROPE BV

Euroweg 2
3825 HD AMERSFOORT
The Netherlands
www.yokogawa.com/eu

YOKOGAWA ELECTRIC ASIA Pte. LTD.

5 Bedok South Road
Singapore 469270
Singapore
www.yokogawa.com/sg

YOKOGAWA CHINA CO. LTD.

3F Tower D Cartelo Crocodile Building
No.568 West Tianshan Road Changing District
Shanghai, China
www.yokogawa.com/cn

YOKOGAWA MIDDLE EAST B.S.C.(c)

P.O. Box 10070, Manama
Building 577, Road 2516, Busaiten 225
Muharrag, Bahrain
www.yokogawa.com/bh

Yokogawa has an extensive sales and distribution network. Please refer to the European website (www.yokogawa.com/eu) to contact your nearest representative.

**YOKOGAWA** ◆

IM 12B6V1-01E-E

Printed in The Netherlands, 05-905 (A) I

Subject to change without notice

Copyright ©