

1. GENERAL

1.1 DIMENSIONS

Construction details and dimensions are shown in figure 1 and 2. The electrodes meet the requirements of DIN 19263.

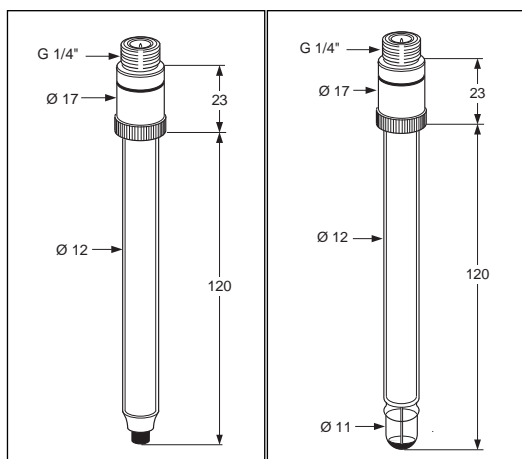
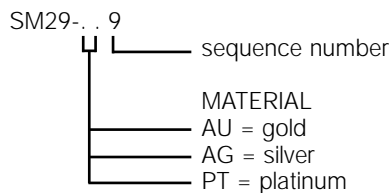

Fig.1 SM29-AG9

Fig.2 SM29-AU9, SM29-PT9

1.2. TYPE NUMBER

The type numbers of Redox electrodes indicate their material of construction and are arranged as follows:



1.3. SPECIFICATIONS

The operating temperature range of the Redox electrodes is between 0 and 150°C at a pressure of 1000 kPa, they can be steam sterilised and are suitable for hygienic applications.

1.4. LIFETIME

Avoid the use of the following metals in the mentioned processes. These will decrease the lifetime of the electrodes severely.

- Platinum : Chlorine and hypchlorite
- Gold : Amalgamation and cyanide
- Silver : Ammonia and nitric acid

2. INSTALLATION

2.1. PREPARATION FOR USE

After removing the protective cover cap and the dust cap of the connector, the electrode is ready for use.

2.2. MOUNTING

The electrode must be fitted with an electrode cable (type WU20(D)-PC..) marked with a red strip. The method of inserting an electrode in a fitting is shown in figures 4a and 4b.

Redox electrodes are suitable for use with any YOKOGAWA cable fitted with the standard nut, the dimensions of which is shown in figure 3. The nut can be ordered separately under part number K1500DW.

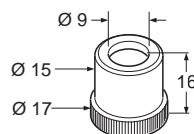

Fig.3. K1500DW (set of 12 cable nuts).

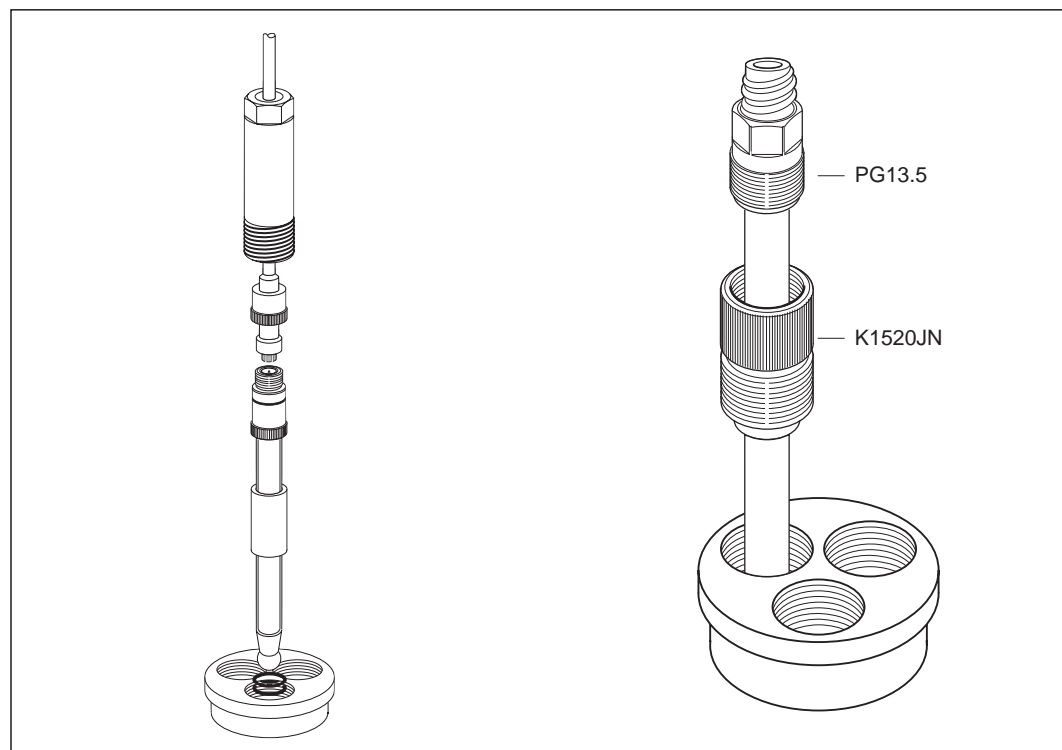

Fig. 4a. Standard mounting with mounting set FP20-R12(M), FP20-S12(M)

Fig. 4b. Mounting PG13,5 in Yokogawa fitting using the adapter K1520JN (PVC-C) or K1500DV (PVDF)

2.3. FUNCTIONAL CHECK AND CALIBRATION

A check for correct functioning of a redox electrode can easily be made using a buffer solution of 6.87 and/or 4.01 pH with quinhydrone. When 1-20 grams (± 1 teaspoon) quinhydrone is added to each buffer, it will produce a stable Redox potential of 96 mV and 265 mV respectively. Mostly only 1-point calibrations are performed. Some analysers also have the possibility to adjust the slope (2-point calibration.)

2.4. ELECTRODE COMBINATIONS

The Redox electrode can be used in combination with all reference electrodes (with yellow marking strip.) The application range and the potential must be considered. The potential of reference electrodes is depending on their composition. A table with the actual values for each system is given next. All values refer to 25 °C. The reference system is also indicated on the textplate of the electrode

System	Fill solution	Value against Standard Hydrogen Electrode
Ag/AgCl	1M KCl	233 mV
Ag/AgCl	sat. KCl	196 mV

A glass electrode can also be used as a reference electrode. This requires an analyser with two high ohmic inputs.

3. USE AND MAINTENANCE

3.1. CLEANING

The electrode should be cleaned with care using a soft cloth or tissue soaked in soap suds, alcohol, acetone or white spirit. If the deposit is persistent it may be removed using a domestic washing liquid diluted with water. This method can affect the sensitive metal layer of the electrode and consequently, precaution is required.

3.2. STORAGE

Electrodes which are not in use for a longer period of time should be removed and stored dry.

3.3. INSULATION

It is essential that a high insulation resistance is maintained between the Redox electrode and its screen. This means that the correct electrode cable must be used and the connector kept dry and clean at all times. If a connection box is used this too must be the approved type and be maintained in a clean and dry condition.

User Manual

Directions for use Redox Electrodes

YOKOGAWA  IM 12C6J1-10E-H
02-209 (A) Q

Printed in The Netherlands,
Subject to change without notice
Copyright©