

3. USE AND MAINTENANCE

During a measurement with reference electrodes there must be good electrical contact between the reference system and process liquid. To guarantee this electrical contact, it is necessary to ensure there is sufficient electrolyte solution in the electrode or in the electrolyte reservoir.

In circumstances where the concentration is not stated on the type plate, a saturated KCl solution of KCl in demi-water should be used to refill the electrode. When the concentration is stated e.g. Ag (3.3M) the electrode must be filled with 3.3 molal KCl. Order a 3.3M solution by part number K1500VA.

Types SR20(D)-..2.

The electrodes of this type are filled with a gelled electrolyte solution and refilling is not necessary. When there is insufficient electrolyte solution the electrode has probably been used at too high a temperature and therefore replacement by another type of reference electrode is recommended.

Types SR20(D)-AC32

To refill electrodes of this type a vacuum pump must be connected to the bottom of the electrode. Figure 13. On removing the electrode cap the pump will contract the bellow and refilling with electrolyte solution can be made.

ATTENTION:

The pump may be removed after replacing the electrode cap. It is recommended to replace the O rings (part number set of 5 O-rings: K1500GE).

If no vacuum pump is available, unscrew the electrode cap. Press down the bellow by means of a clean rod with a round top to prevent for damage of the bellow. Close the bottom end of the electrode with the enclosed rubber plug. After removing the rod the electrode can be filled with electrolyte solution. Mount the electrode cap and remove the rubber plug.

4. STORAGE

When a reference electrode is to remain unused for a long period it is necessary to fill the electrode completely with electrolyte solution, to close the refill opening, and to protect the diaphragm against drying out by fitting the protection sleeve. This protection sleeve must also be filled with electrolyte solution.

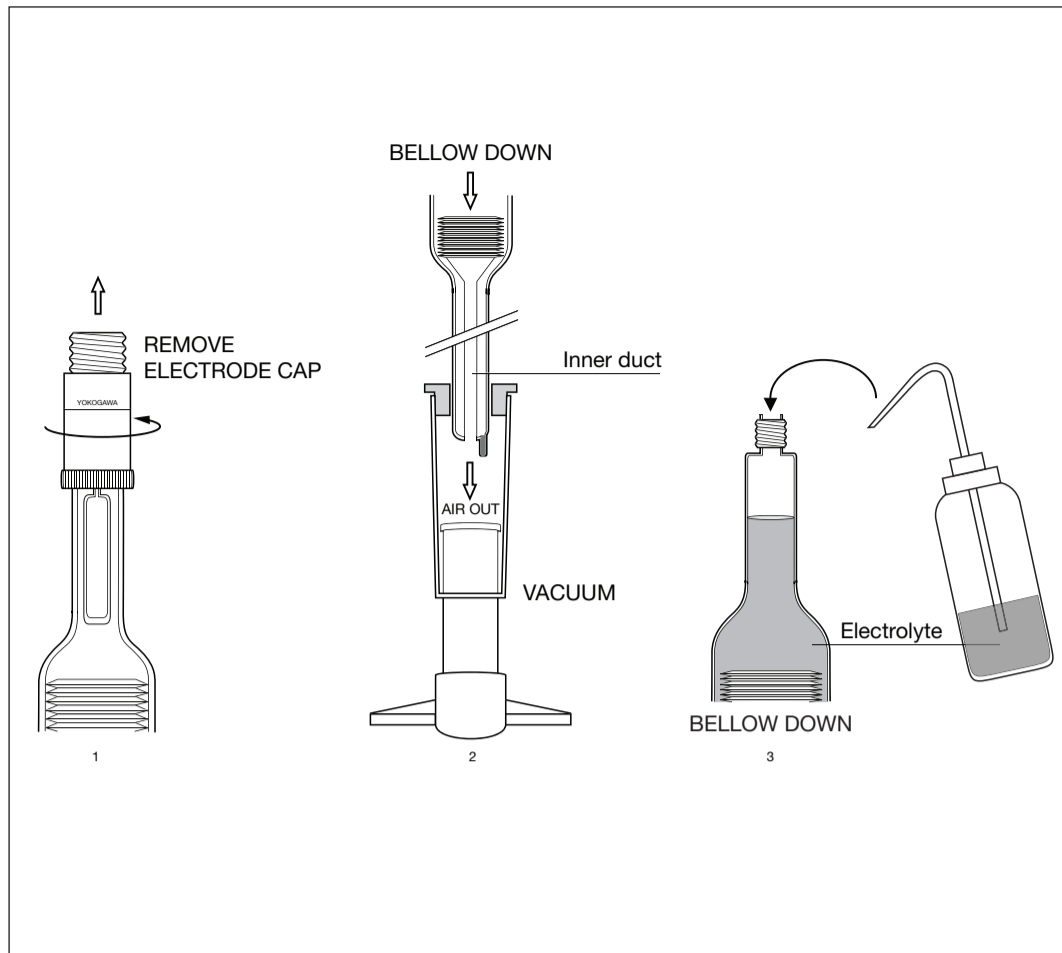

Figure 12. Refill Bellomatic (SR20(D)-AC32)

Electrodes of type SR20(D)-AC32 have an inner duct (figure 12) which contact the bellow with the process liquid. This duct must be sealed with the rubber plug.

With the electrodes (types SR20-AS52) the sleeve must be loosened and lifted. The hole in the fixed part must be closed by means of a protective sleeve or tape.

5. FAULTS

Generally, faults are caused by:

a. leakage to earth

Fault indications can be expected when the resistance between reference system and screening falls below 10^7 ohm. When a fault

occurs, first check if the electrode cable is in good condition and if the connector contacts and the terminals in the measuring instrument or connection box are clean and dry.

b. diaphragm fouling

Strongly polluted liquids can cause the diaphragm to foul very quickly. As a result, there will be a 'transition' resistance over the diaphragm. When this resistance exceeds $10^4 \Omega$ there will be instability and faulty indication of the measured value. The above particularly occurs with flow type electrodes when the outlet flow of electrolyte solution is too low, e.g. with adverse pressure variations due to the medium, pumps or too low electrolyte level.

Fouled electrodes can be cleaned with hot water in conjunction with a domestic washing solution if necessary. When the fouling is caused by fat or hydroxides (lime) cleaning by means of an organic solvent or diluted acid respectively is recommended.

The diaphragm of electrodes with a ceramic diaphragm (types SR20-AC..) can be cleaned by rubbing it on emery paper.

Electrodes with a sleeve (types SR20-AS52) can be cleaned after lifting the loose part.

It may be necessary with non-flow electrodes (types SR20-AP2.) to place the electrode for some time in an electrolyte solution of 80°C . The electrode must remain in this solution until this solution has completely cooled.

c. poisoning

A reference electrode can be poisoned by the penetration of the process liquid or by diffusion of components of the process medium through the diaphragm. In addition, the inner liquid in combinations with dissolved particles from the process medium can give deposits which block the diaphragm (e.g. silver chloride + sulfide \rightarrow deposits of silver sulfide). When poisoning occurs replacement of the electrode will normally be necessary. It is recommended if poisoning of non-flow electrodes occurs to use another type of electrode.

d. poor conductivity of the process liquid

When the electrical conduction of a process liquid is very low an instability of reading will occur. This problem may be cured by adding electrolyte solution to the process liquid or by making the reference input of the measuring instrument high impedance.

6. CHECK

A quick check for correct functioning of a reference electrode can be made by connecting the electrode to the reference input of a pH meter. A known good reference electrode with the same reference system should be connected to the glass electrode input. After immersing both electrodes in a buffer solution the reading should be stable. The reading must be adjustable to pH 7 by means of the zero potentiometer ('ass. pot.'). If this is possible the reference electrode is functioning correctly.

YOKOGAWA
ELECTRIC CORPORATION
World Headquarters
9-32, Nakacho 2-chome, Musashino-shi
Tokyo 180-8750
Japan
www.yokogawa.com

YOKOGAWA
CORPORATION OF AMERICA
2 Dart Road
Newman GA 30265
USA
www.yokogawa.com/us

YOKOGAWA EUROPE B.V.
Euroweg 2
3825 HD Amersfoort
The Netherlands
www.yokogawa.com/eu

YOKOGAWA
ELECTRIC ASIA Pte. LTD.
5 Bedok South Road
Singapore 469270
Singapore
www.yokogawa.com/sg

YOKOGAWA
CHINA CO. LTD.
3F Tower D
Cartelo Crocodile Building
No.568 West Tianshan Road
Changding District
Shanghai, China
www.yokogawa.com/cn

YOKOGAWA
MIDDLE EAST B.S.C.(c)
P.O. Box 10070, Manama
Building 577, Road 2516,
Busaiten 225
Muharrag, Bahrain
www.yokogawa.com/bh

Yokogawa has an extensive sales and distribution network. Please refer to the European website (www.yokogawa.com/eu) to contact your nearest representative.



YOKOGAWA

User Manual

Directions for use reference Electrodes

YOKOGAWA IM 12B6J1-10E-E
0701012 (A) I

Printed in The Netherlands,
Subject to change without notice
Copyright©

1. GENERAL

1.1 General spec's for NON-Flow electrodes

- Maximum process pressure: 500 kPa (5 bar).
- High quality Ag/AgCl reference system (pin) which can stand high temperatures and temperature fluctuations.

SR20(D)-AC22

- Temperature / pressure variation compensation.
- To be used in non-polluting fluids.
- Saturated KCl-solution (pellets).
- For low ionic applications and high temperatures.
- Temperature range: 0 to 120 °C.
- Diaphragm resistance (25 °C) <10kΩ.

SR20(D)-AP24

- General purpose PTFE diaphragm electrode.
- Large PTFE diaphragm.
- Thickened KCl-solution (3.3m).
- Temperature range: 0 to 80 °C.
- Diaphragm resistance (25 °C) <10kΩ.

SR20(D)-AP26

- When KCl is prohibited in the application.
- Double junction, thickened KNO₃ in buffer compartment.
- Large PTFE diaphragm against pollution.
- Thickened KCl-solution (3.3m).
- Temperature range: 0 to 80 °C.
- Diaphragm resistance (25 °C) <10kΩ.

1.2 General spec's for Flowing electrodes

- Liquid flow output preventing diaphragm fouling and poisoning the reference system.
- High quality Ag/AgCl reference system (pin) which can stand high temperatures and temperature fluctuations.
- 3.3m KCl electrolyte.

SR20(D)-AC32

- Automatic compensation for process pressure variations.
- Constant flow of reference liquid, independent of the process pressure variations for minimal diffusion potential, 0.5ml/day.
- Suitable for pure water applications and for polluting fluids.
- Refillable, large KCl reservoir.
- Maximum process pressure 1000 kPa (10 bar).
- Temperature range: 0 to 120 °C.
- Diaphragm resistance (25°C) < 10 kΩ.

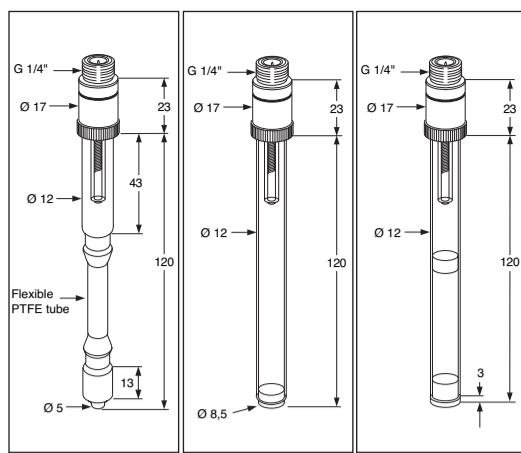

Fig.1 SR20-AC22 Fig.2. SR20-AP24 Fig.3 SR20-AP26

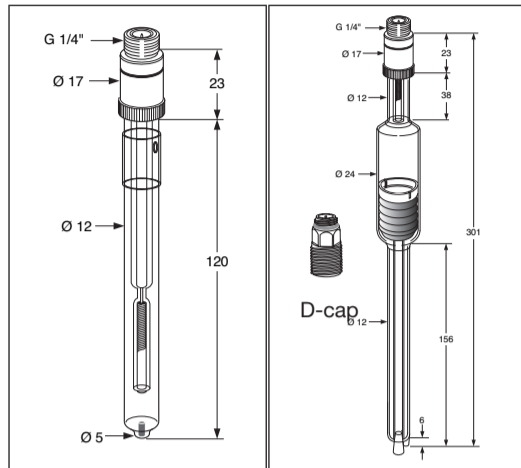

Fig.4 SR20-AC11

Fig.5 SR20(D)-AC32

NOTE: The flow is highly dependent on temperature. When using the electrode continuously at temperature over 70 °C it is recommended to fill the electrode with a reference liquid having a higher viscosity, ordemrs. K1500GG (1m) or K1520VN (3.3m).

SR20(D)-AS52

- Sleeve junction is suitable for pure water applications and very strong polluted liquids.
- Maximum process pressure 100 kPa (atm).
- Temperature range: 0 to 100 °C
- Diaphragm resistance (25°C) < 10 kΩ.
- Flow Rate at 25°C: 5.0 ml/day at 10 kPa overpressure.

1.3. TYPE NUMBER

The type number of a reference electrode as indicated on the type plate is arranged as follows:

SR20(D)-. . .

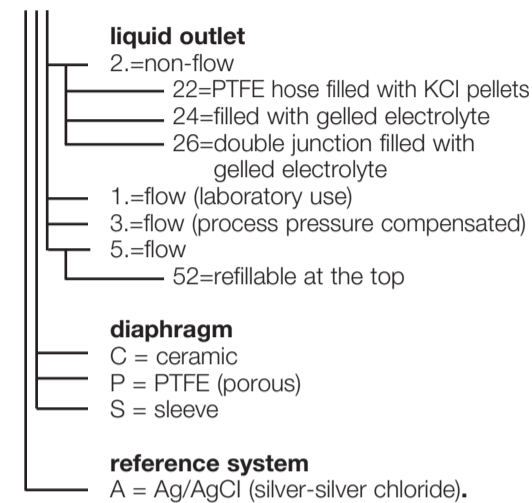

1.4. SPECIFICATIONS

The specifications, the temperature application range, the reference system, etc. of an electrode are all clearly shown on the electrode cap type plate. The resistance of the diaphragm depends on the type of the electrode but must be maximum 10 kohm at 25°C in all circumstances.

2. INSTALLATION

2.1. PREPARATION FOR USE

When dispatched the reference electrode has a protection sleeve around the diaphragm.

Flow electrodes (types SR20-..52.) have a refill opening which is sealed with a cap. The inner duct of the process pressure compensated Bellomatic electrodes (type SR20-AC32) is provided with a rubber plug. Do not throw away the rubber plug as it is needed for re-filling.

NOTE:

Before installation all the above mentioned items must be removed. In addition, reference electrodes, with polished sleeve junction (types SR20-AS52) will need to have their polished ends telescoped into each other. If required, the flow electrodes may be connected to a reservoir of electrolyte solution. To maintain a correct flow the reservoir must be placed so that the pressure at the inner side of the diaphragm

exceeds the process pressure (for open systems the level of the electrolyte must be above the level of the measuring liquid). Only under these circumstances will correct electrical contact between reference system and measuring liquid be guaranteed.

2.2. MOUNTING

The reference electrode must be connected to an electrode cable (type WU20(D)-PC..) marked with a yellow strip.

The method of mounting certain types of reference electrodes (types SR20-A.2.) in flow, immersion or other fittings is similar to that for glass electrodes (see directions for use of glass electrodes) or figure 8.

When mounting the Bellomatic reference electrodes a special holder is required.

Part number: FP20(D)-S13 (stainless steel) for mounting in electrode fittings with the type number

FF20-, FS20-, FD20-. The electrodes fit any Yokogawa cable fitted with the standard nut shown in figure 12. The nut has order number K1500DW.

Yokogawa has her own specific cap (Y-CAP). The process connection for this cap is M25 and can be mounted in all the fittings that are available in our program.

Secondly we have the D-CAP, which has a PG13,5 process connection.

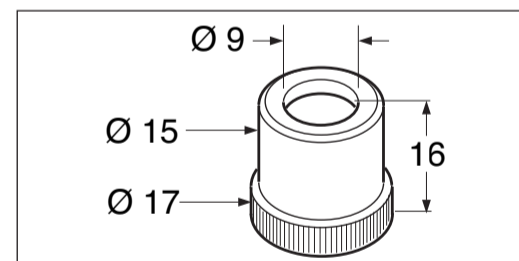
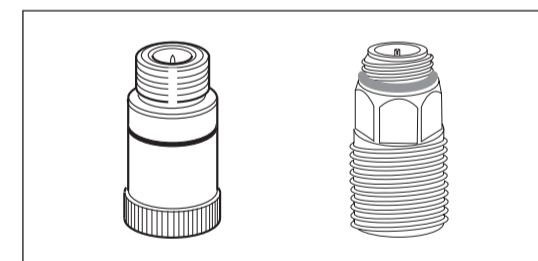

Fig.12. K1500DW (set of 12 cable nuts).

The sensors with D-CAP fit into all our fittings when using the adapter K1500DV (PVDF) or adapter K1520JN (PVC). The SR20D-AC32 needs a mounting kit, when mounted into our fittings. One is specifically for the Y-cap FS20-S13 another for the D-CAP (FP20-S13D). The SR20-AS52 and AC52 also need a mounting kit to fit into a pH fitting regardless if it is a D- or Y-CAP (K1500BY). With the FD20, FF20, FS20 fittings this mounting kit can be ordered as an option (option /R).



Y-CAP

D-CAP

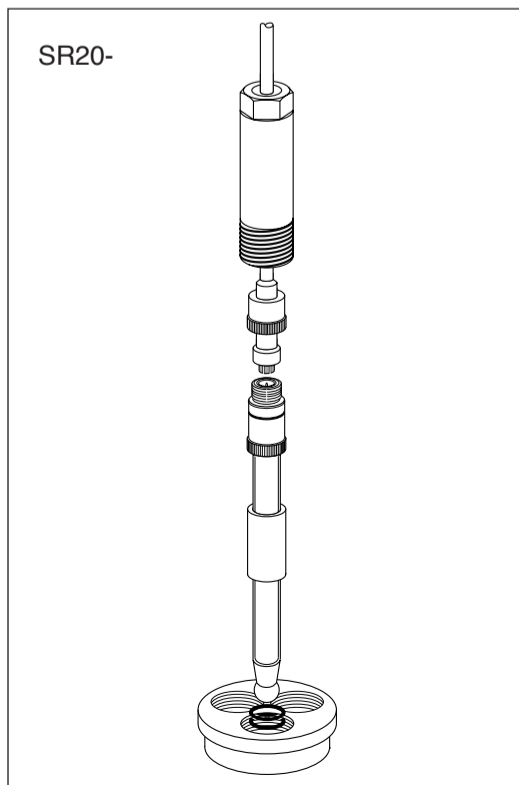

Figure 8. Standard mounting options

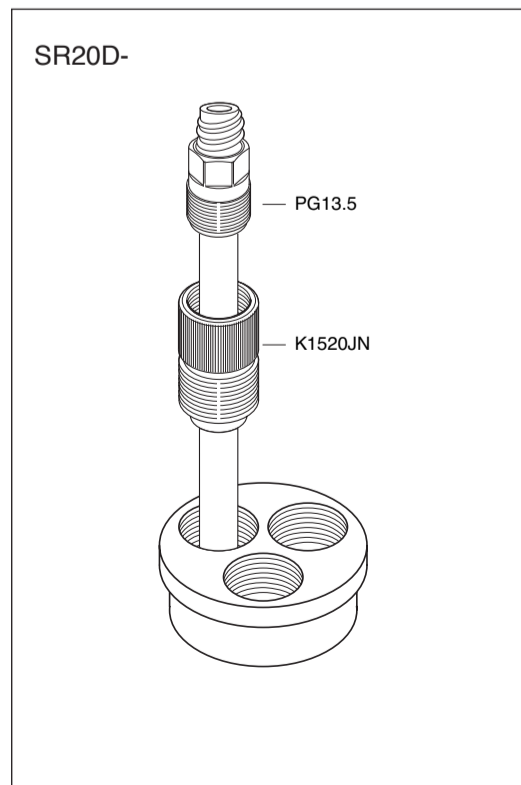

Fig.9 Mounting PG13,5 in Yokogawa fitting using the adapter K1520JN (PVC-C) or K1500DV (PVDF)

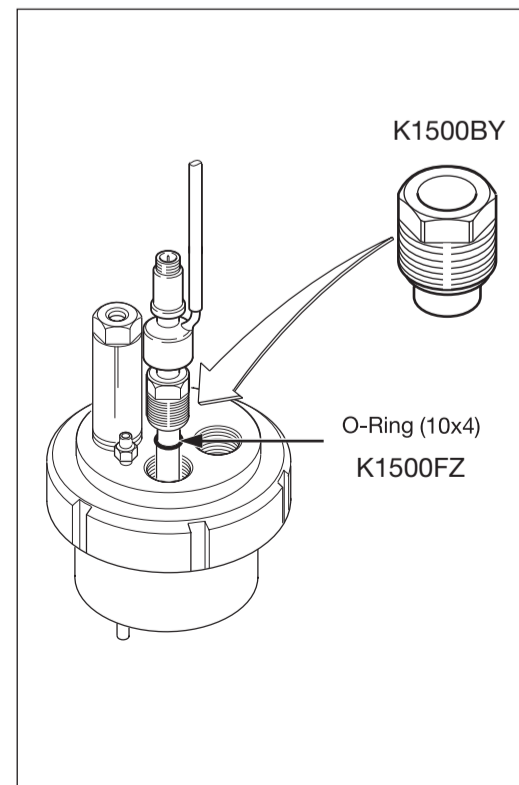

Figure 10. SR20-AC52, SR20-AS52

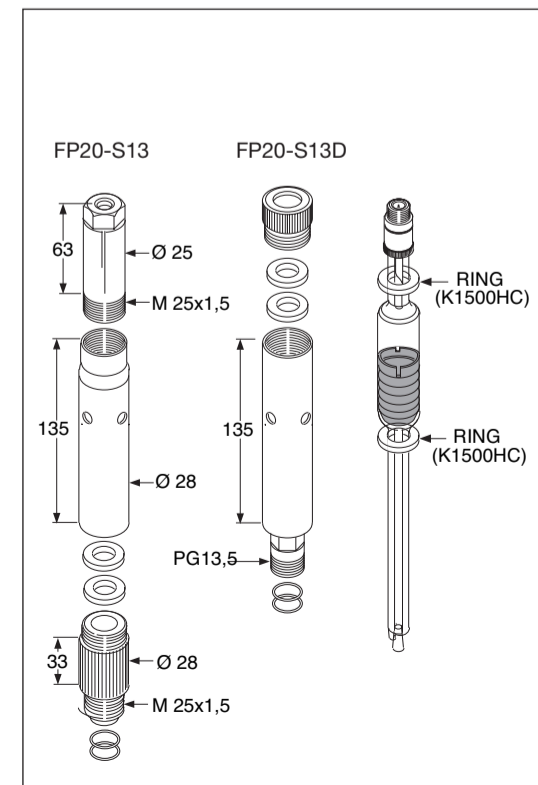

Figure 11. Mounting kit SR20-AC32