

## Oxygen Probe Protectors and Supports

### Probe Protector (ZR22R)

The probe protector (ZR22R) is a stainless steel tube attached to a flange that provides full length protection for the ZR22 oxygen probe. The probe protector should be used on the ZR22 oxygen probe when there is high particulate load (coal fired) and a flow rate of 10m/sec (33ft/sec) or greater.

- Material: 316/316L Stainless Steel, Schedule 10 pipe
- Flange: 4" ANSI Class, 150# FF Flange
- Four holes are countersunk for installation to the process flange
- Available Lengths: 0.4 meters to 3 meters

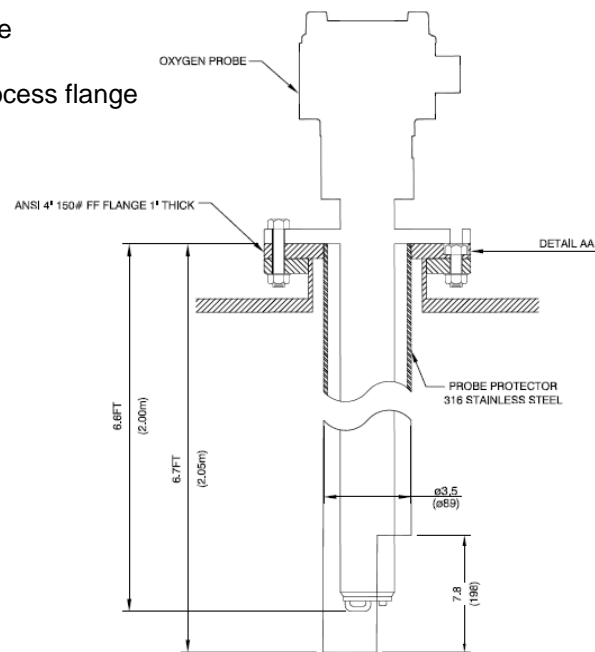
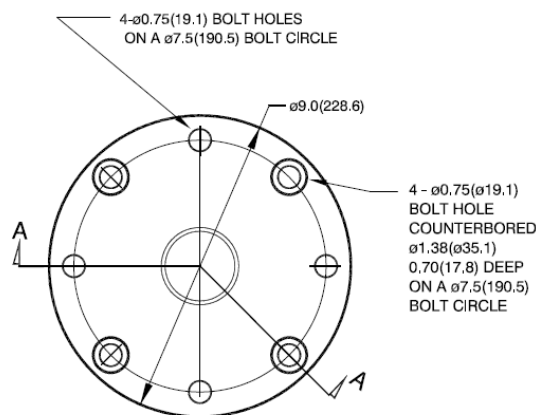

### Probe Protector (ZR22R) Installation

The probe protector (ZR22R) flange has 4 recessed holes and four regular holes. This allows for the probe protector to be integrally mounted to the process flange and the ZR22 oxygen probe flange without degrading structural integrity.

1. Install the probe protector (ZR22R) with the long end toward the process gas flow. Install the bolts into the recessed holes of the ZR22R flange

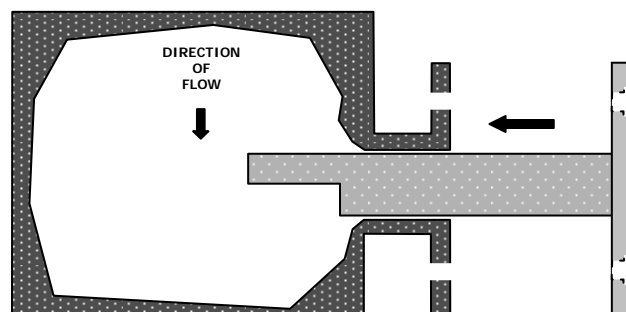

2. Insert the probe protector mounting bolts into the recessed holes of the probe protector flange, and through the process flange. Torque as necessary to achieve a good seal.

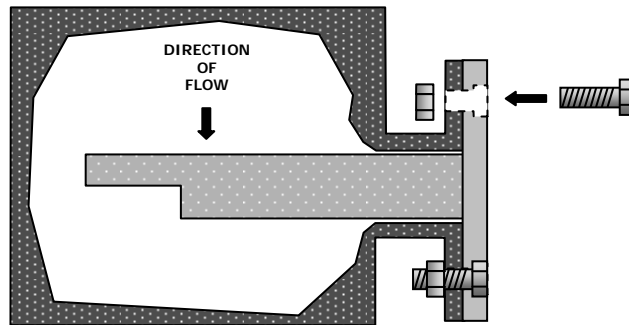

3. Install the ZR22 oxygen probe into the probe protector and process flange.

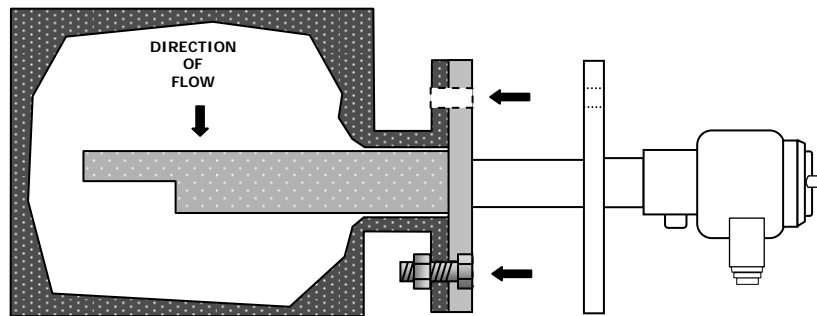

4. Insert the ZR22 mounting bolts into the ZR22 oxygen probe flange. Torque as required to achieve a good seal between the probe flange and the probe protector flange.

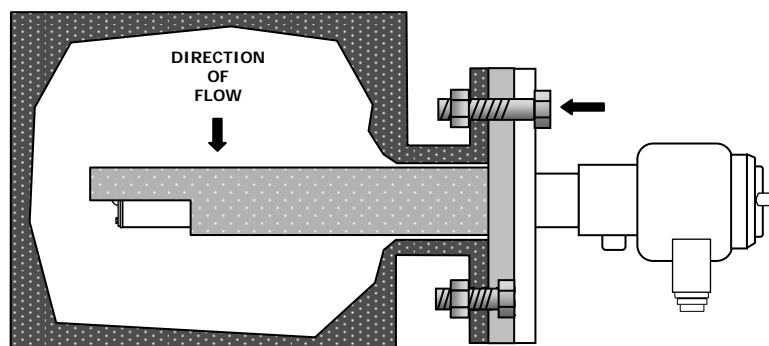

### Probe Support (ZR22V)

The probe support (ZR22V) provides additional structural support for probes over 3 meters in length. The probe support is suitable for applications without particulates, such as natural gas fired applications.

- Material: 316/316L Stainless Steel, Schedule 10 pipe; 1.5m insertion length
- Flange: 4" ANSI Class, 150# FF Flange
- Four holes are countersunk for installation to the process flange

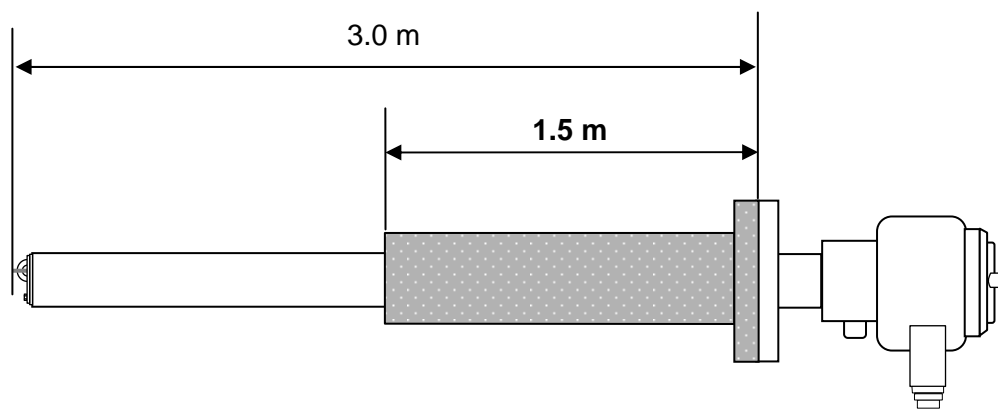

### Probe Support (ZR22V) Installation

1. Install the probe support (ZR22V) into the process flange opening.

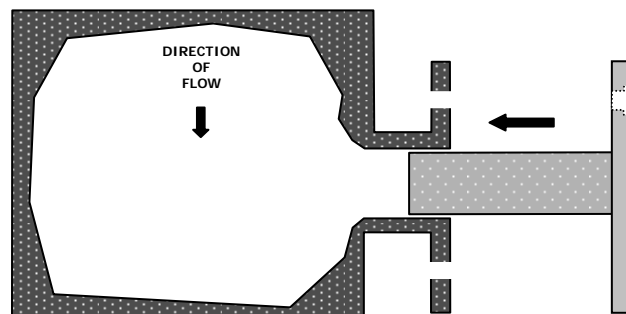

2. Install the probe support mounting bolts into the recessed holes of the probe support, and torque as necessary to achieve a good seal.

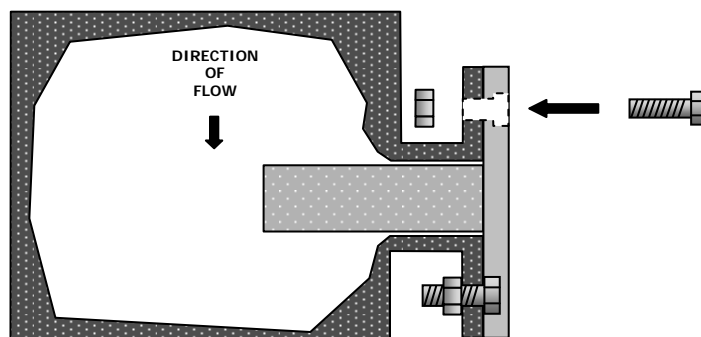

3. Install the ZR22 oxygen probe into the probe protector and process flange.

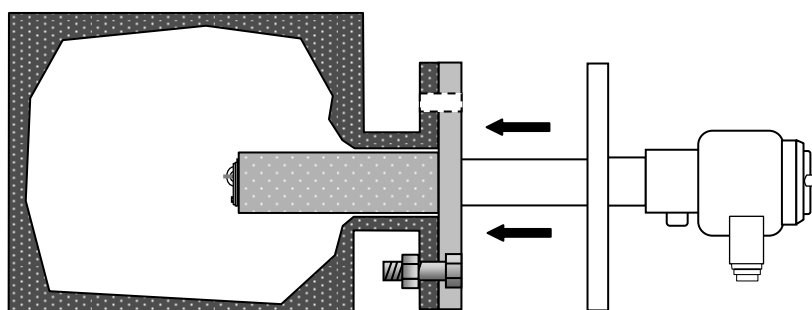

4. Insert the ZR22 mounting bolts into the ZR22 oxygen probe flange. Torque as required to achieve a good seal between the probe flange and the probe protector flange.

