

General Specifications

EJX310A Absolute Pressure Transmitter



GS 01C25D01-01E

[Style: S2]

The high performance absolute pressure transmitter EJX310A features single crystal silicon resonant sensor and is suitable to measure liquid, gas, or steam pressure. The EJX310A outputs a 4 to 20 mA DC signal corresponding to the measured pressure. It also features quick response, remote setup and monitoring via BRAIN or HART communications, and diagnostics. The multi-sensing technology provides the advanced diagnostic function to detect such abnormalities as an impulse line blockage or heat trace breakage.

EJX series is certified by TÜV organization to SIL2 for safety requirement.

STANDARD SPECIFICATIONS

Refer to GS 01C25T02-01E for Fieldbus communication type marked with "◇."

SPAN AND RANGE LIMITS

Measurement Span/Range	kPa abs	psi abs (/D1)	mbar abs(/D3)	mmHg abs(/D4)	
L	Span	0.5 to 10	0.15 to 2.95 inHg	5 to 100	3.8 to 75
	Range	0 to 10	0 to 2.95 inHg	0 to 100	0 to 75
M	Span	1.3 to 130	0.39 to 38 inHg	13 to 1300	9.8 to 970
	Range	0 to 130	0 to 38 inHg	0 to 1300	0 to 970
A	Span	0.0175 to 3.5 MPa	2.5 to 500	0.175 to 35 bar	0.175 to 35 kgf/cm ²
	Range	0 to 3.5 MPa	0 to 500	0 to 35bar	0 to 35 kgf/cm ²
B	Span	0.08 to 16 MPa	12 to 2300	0.8 to 160bar	0.8 to 160 kgf/cm ²
	Range	0 to 16 MPa	0 to 2300	0 to 160bar	0 to 160 kgf/cm ²

T01E.EPS

PERFORMANCE SPECIFICATIONS

Zero-based calibrated span, linear output, wetted parts material code 'S' and silicone oil, unless otherwise mentioned.

For Fieldbus communication type, use calibrated range instead of span in the following specifications.

Specification Conformance

EJX series ensures specification conformance to at least $\pm 3\sigma$.

Reference Accuracy of Calibrated Span

(includes terminal-based linearity, hysteresis, and repeatability)

Measurement span	L	
Reference accuracy	$X \leq \text{span}$	$\pm 0.075\%$ of Span
	$X > \text{span}$	$\pm (0.02+0.03 \text{ URL}/\text{span})\%$ of Span
X	5.4 kPa abs (1.6 inHg abs)	
URL (upper range limit)	10 kPa abs (2.95 inHg abs)	

T02E_02.EPS



Measurement span	M	
Reference accuracy	$X \leq \text{span}$	$\pm 0.04\%$ of Span
	$X > \text{span}$	$\pm (0.01+0.005 \text{ URL}/\text{span})\%$ of Span
X	21.4 kPa abs (6.3 inHg abs)	
URL (upper range limit)	130 kPa abs (38.4 inHg abs)	

T03-1E.EPS

Measurement span	A	B
Reference accuracy	$X \leq \text{span}$	$\pm 0.04\%$ of Span
	$X > \text{span}$	$\pm (0.005+0.0035 \text{ URL}/\text{Span})\%$ of Span
X	0.35 MPa abs (50 psia)	1.6 MPa abs (230 psia)
URL (upper range limit)	3.5 MPa abs (500 psia)	16 MPa abs (2300 psia)

T02E.EPS

Ambient Temperature Effects per 28°C (50°F) Change

Capsule	Effect
L	$\pm (0.1\% \text{ of Span} + 0.35\% \text{ of URL})$
M	$\pm (0.04\% \text{ of Span} + 0.035\% \text{ of URL})$
A, and B	$\pm (0.04\% \text{ of Span} + 0.012\% \text{ of URL})$

Power Supply Effects (Output signal code D and E)

$\pm 0.005\%$ per Volt (from 21.6 to 32 V DC, 350 Ω)

Vibration Effects

Less than 0.1% of URL when tested per the requirements of IEC60770-1 field or pipeline with high vibration level (10-60 Hz, 0.21 mm peak to peak displacement/60-2000 Hz 3g)

Mounting Position Effects

Tilting up to 90 degree will cause zero shift up to 0.5 kPa (2.0 inH₂O) which can be corrected by the zero adjustment.

Response Time (All capsules) “◇”

90 msec
When amplifier damping is set to zero and including dead time of 45 msec (nominal)

Minimum Pressure at Calibration*

L capsule: 130 Pa abs (1 mmHg abs)
M, A and B capsules: 2.7 kPa abs (20 mmHg abs)

* If one or two of the calibration points are smaller than the above value, the above pressure is used for testing. In case all of the calibration points are greater than the limit, only the pressure of upper range value (URV) is applied for testing. Specifying option code /S1 with M or A capsule will lower the limit to 130 Pa abs. /S1 is recommended for M capsule when the specified upper range value (URV) is not exceeding 3.4 kPa abs.

FUNCTIONAL SPECIFICATIONS

Output “◇”

Two wire 4 to 20 mA DC output with digital communications, linear or square root programmable. BRAIN or HART FSK protocol are superimposed on the 4 to 20 mA signal.
Output range: 3.6 mA to 21.6 mA
Output limits conform to NAMUR NE43 can be pre-set by option C2 or C3.

Failure Alarm (Output signal code D and E)

Output status at CPU failure and hardware error;
Up-scale: 110%, 21.6 mA DC or more (standard)
Down-scale: -5%, 3.2 mA DC or less
Analog output status at process abnormality (Option code /DG6);
The result of process abnormality detected by the advanced diagnostic function can be reflected to an analog alert status. The following three setting modes are available.

		Mode		
		Burnout	Fall back	Off
Standard		110 %, 21.6mA or more	Holds to a specified value within the output range from 3.6mA to 21.6mA	Not Available (normal output)
Option Code	/C1	-2.5%, 3.6mA or less		
	/C2	-1.25%, 3.8mA or less		
	/C3	103.1%, 20.5mA or more		

T11E.EPS

Damping Time Constant (1st order)

Amplifier damping time constant is adjustable from 0.00 to 100.00 sec by software and added to response time.

Note: For BRAIN protocol type, when software damping is set to less than 0.5 sec, communication may occasionally be unavailable during the operation, especially while output changes dynamically. The default setting of damping ensures stable communication.

Update Period “◇”

Pressure: 45 msec

Zero Adjustment Limits

Zero can be fully elevated or suppressed, within the lower and upper range limits of the capsule.

External Zero Adjustment “◇”

External Zero is continuously adjustable with 0.01 % incremental resolution of span. Re-range can be done locally using the digital indicator with range-setting switch.

Integral Indicator (LCD display) “◇”

5-digit numerical display, 6-digit unit display and bar graph.
The indicator is configurable to display one or up to three of the following variables periodically.; pressure in %, scaled pressure, measured pressure. See also “Factory Setting”.

Burst Pressure Limits

69 MPa (10,000 psi)

Self Diagnostics

CPU failure, hardware failure, configuration error, process alarm for pressure or capsule temperature. User-configurable process high/low alarm for pressure is also available, and its status can be output when optional status output is specified.

Advanced Diagnostics (optional) “◇”

Applicable for Output signal code E and F.

- Impulse line blockage detection
The impulse line condition can be calculated and detected by extracting the fluctuation component from the static pressure signal.
- Heat trace monitoring
The change of the flange temperature calculated by using the two temperature sensors built in the EJX enables to detect the heat trace breakage or the abnormal temperature due to the failure.

Signal Characterizer

User-configurable 10-segment signal characterizer for 4 to 20 mA output.

Status Output (optional, output signal code D and E)

One transistor contact output (sink type) to output the status of user configurable high/low alarm for pressure. Contact rating : 10.5 to 30 V DC, 120 mA DC max. Refer to ‘Terminal Configuration’ and ‘Wiring Example for Analog Output and Status Output.’

SIL Certification

The EJX series transmitters except Fieldbus communication type are certified by RWTÜV Systems GmbH according to the following standards;
IEC 61508: 2000; Part1 to Part 7
Functional Safety of Electrical/electronic/programmable electronic related systems; SIL 2 capability for single transmitter use, SIL 3 capability for dual transmitter use.

NORMAL OPERATING CONDITION (Optional features or approval codes may affect limits.)

Ambient Temperature Limits

-40 to 85°C (-40 to 185°F)
-30 to 80°C (-22 to 176°F) with LCD display

Process Temperature Limits

-40 to 120°C (-40 to 248°F) – M, A & B capsules
-40 to 100°C (-40 to 212°F) – L capsule

Ambient Humidity Limits

0 to 100% RH

Maximum Over Pressure

Capsule	Pressure
L and M	500 kPa abs (72 psia)
A	16 MPa abs (2300 psia)
B	25 MPa abs (3600 psia)

**Working Pressure Limits (Silicone oil)
Maximum Pressure Limits**

Capsule	Pressure
L	10 kPa abs (2.95 inHg abs)
M	130 kPa abs (38 inHg abs)
A	3.5 MPa abs (500 psia)
B	16 MPa abs (2300 psia)

Minimum Pressure Limit

See graph below

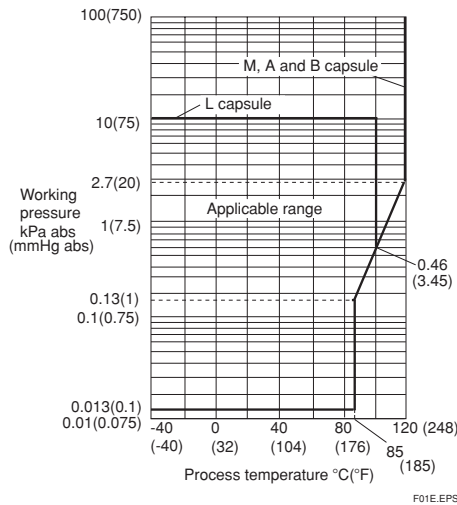

Figure 1. Working Pressure and Process Temperature

Supply & Load Requirements

(Output signal code D and E. Optional features or approval codes may affect electrical requirements.)

With 24 V DC supply, up to a 550 Ω load can be used. See graph below.

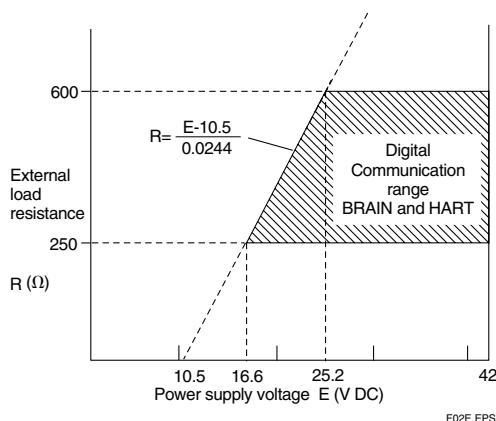

Figure 2. Relationship Between Power Supply Voltage and External Load Resistance

Supply Voltage “◇”

10.5 to 42 V DC for general use and flameproof type.
10.5 to 32 V DC for lightning protector (option code /A.)
10.5 to 30 V DC for intrinsically safe, type n, or non-incendive.
Minimum voltage limited at 16.6 V DC for digital communications, BRAIN and HART

Load (Output signal code D and E)

0 to 1290 Ω for operation
250 to 600 Ω for digital communication

Communication Requirements “◇”

(Approval codes may affect electrical requirements.)

BRAIN

Communication Distance

Up to 2 km (1.25 miles) when using CEV polyethylene-insulated PVC-sheathed cables. Communication distance varies depending on type of cable used.

Load Capacitance

0.22 μF or less

Load Inductance

3.3 mH or less

Input Impedance of communicating device

10 kΩ or more at 2.4 kHz.

EMC Conformity Standards CE , N200

EN61326-1 Class A, Table2 (For use in industrial locations)
EN61326-2-3

PHYSICAL SPECIFICATIONS

Wetted Parts Materials

Diaphragm, Cover Flange, Process Connector, Capsule Gasket, and Vent/Drain Plug
Refer to “MODEL AND SUFFIX CODE.”

Process Connector Gasket

PTFE Teflon
Fluorinated rubber for Option code /N2 and /N3

Non-wetted Parts Materials

Bolting

ASTM-B7 carbon steel, 316L SST stainless steel, or ASTM grade 660 stainless steel

Housing

Low copper cast aluminum alloy with polyurethane, mint-green paint (Munsell 5.6BG 3.3/2.9 or its equivalent), or ASTM CF-8M stainless steel.

Degrees of Protection

IP67, NEMA4X, JIS C0920

Cover O-rings

Buna-N

Name plate and tag

304 SST, 316 SST (optional)

Fill Fluid

Silicone, Fluorinated oil (optional)

Weight

[Installation code 7, 8, and 9]
2.8 kg(6.2 lb) without integral indicator, mounting
bracket, and process connector.
Add 1.5 kg (3.3 lb) for Amplifier housing code 2.

Connections

Refer to "MODEL AND SUFFIX CODE."
Process connection of cover flange: IEC61518

< Related Instruments >

Power Distributor: Refer to GS 01B04T01-02E or
GS 01B04T02-02E
BRAIN TERMINAL: Refer to GS 01C00A11-00E

< Reference >

1. Teflon; Trademark of E.I. DuPont de Nemours & Co.
 2. Hastelloy; Trademark of Haynes International Inc.
 3. HART; Trademark of the HART Communication Foundation.
 4. FOUNDATION Fieldbus; Trademark of Fieldbus Foundation.
- Other company names and product names used in this material are registered trademarks or trademarks of their respective owners.

MODEL AND SUFFIX CODES

Model	Suffix Codes	Description
EJX310A	Absolute pressure transmitter
Output Signal	-D -E -F	4 to 20 mA DC with digital communication (BRAIN protocol) 4 to 20 mA DC with digital communication (HART protocol) Digital communication (FOUNDATION Fieldbus protocol, refer to GS 01C25T02-01E)
Measurement span (capsule)	L M A B	0.5 to 10 kPa abs (0.15 to 2.95 inHg abs) 1.3 to 130 kPa abs (0.39 to 38 inHg abs) 0.0175 to 3.5 MPa abs (2.5 to 500 psia) 0.08 to 16 MPa abs (12 to 2300 psia)
Wetted parts material *2	S	Refer to "Wetted Parts Material" Table.
Process connections	0 1 2 3 4 ☆ 5	without process connector (Rc1/4 female on the cover flanges) with Rc1/4 female process connector with Rc1/2 female process connector with 1/4 NPT female process connector with 1/2 NPT female process connector without process connector (1/4 NPT female on the cover flanges)
Bolts and nuts material	J G C	ASTM-B7 carbon steel 316L SST stainless steel ASTM grade 660 stainless steel
Installation	☆ -3 -7 -8 -9 -B -U	Vertical piping, right side high pressure, and process connection down side Vertical piping, left side high pressure, and process connection down side Horizontal piping and right side high pressure Horizontal piping and left side high pressure Bottom Process Connection, left side high pressure: Universal flange
Amplifier housing	1 2	Cast aluminum alloy ASTM CF-8M stainless steel *3 *5
Electrical connection	☆ 0 2 4 5 7 9 A C D	G1/2 female, one electrical connection without blind plugs 1/2 NPT female, two electrical connections without blind plugs M20 female, two electrical connections without blind plugs G1/2 female, two electrical connections and a blind plug *4 1/2 NPT female, two electrical connections and a blind plug *4 M20 female, two electrical connections and a blind plug *4 G1/2 female, two electrical connections and a 316 SST blind plug 1/2 NPT female, two electrical connections and a 316 SST blind plug M20 female, two electrical connections and a 316 SST blind plug
Integral indicator	☆ D E N	Digital indicator Digital indicator with the range setting switch *1 (None)
Mounting bracket	☆ B D G J K M N	304 SST 2-inch pipe mounting, flat type (for horizontal piping) 304 SST 2-inch pipe mounting, L type (for vertical piping) 304 SST 2-inch pipe mounting (for bottom process connection type) 316 SST 2-inch pipe mounting, flat type (for horizontal piping) 316 SST 2-inch pipe mounting, L type (for vertical piping) 316 SST 2-inch pipe mounting (for bottom process connection type) (None)
Optional code		/ <input type="checkbox"/> Optional specification

T04E.EPS

The "☆" marks indicate the most typical selection for each specification.

*1: Not applicable for output signal code **F**.

*2: ⚠ Users must consider the characteristics of selected wetted parts material and influence of process fluids. Specifying inappropriate materials has the potential to cause serious damage to human body and plant facilities resulted from an unexpected leak of the corrosive process fluids.

*3: Not applicable for electrical connection code **0**, **5**, **7** and **9**.

*4: Material of a blind plug is aluminum alloy or 304 SST.

Table. Wetted Parts Materials

Wetted parts material code	Cover flange and process connector	Capsule	Capsule gasket	Drain/Vent plug
S #	ASTM CF-8M*1	Hastelloy C-276 *2 (Diaphragm) 316L SST (Others)	Teflon-coated 316L SST	316 SST

M04E.EPS

*1: Cast version of 316 SST. Equivalent to SCS14A.

*2: Hastelloy C-276 or ASTM N10276.

The '#'marks indicate the construction materials conform to NACE material recommendations per MR01-75. For the use of 316 SST material, there may be certain limitations for pressure and temperature. Please refer to NACE standards for details.

OPTIONAL SPECIFICATIONS (For Explosion Protected type) “◇”

Item	Description	Code
Factory Mutual (FM)	FM Explosionproof Approval *1 Applicable Standard: FM3600, FM3615, FM3810, ANSI/NEMA 250 Explosionproof for Class I, Division 1, Groups B, C and D, Dust-ignitionproof for Class II/III, Division 1, Groups E, F and G, in Hazardous locations, indoors and outdoors (NEMA 4X) Temperature class: T6, Amb. Temp.: -40 to 60°C (-40 to 140°F)	FF1
	FM Intrinsically safe Approval *1*2 Applicable Standard: FM3600, FM3610, FM3611, FM3810 Intrinsically Safe for Class I, Division 1, Groups A, B, C & D, Class II, Division 1, Groups E, F & G and Class III, Division 1, Class I, Zone 0, in Hazardous Locations, AEx ia IIC Nonincendive for Class I, Division 2, Groups A, B, C & D, Class II, Division. 2, Groups F & G, and Class III, Division 1, Class I, Zone 2, Group IIC, in Hazardous Locations Enclosure: "NEMA 4X", Temp. Class: T4, Amb. Temp.: -60 to 60°C (-75 to 140°F) Intrinsically Safe Apparatus Parameters [Groups A, B, C, D, E, F and G] Vmax=30 V, Imax=200 mA, Pmax=1 W, Ci=6 nF, Li=0 μH [Groups C, D, E, F and G] Vmax=30 V, Imax=225 mA, Pmax=1 W, Ci=6 nF, Li=0 μH	FS1
	Combined FF1 and FS1 *1*2	FU1
GENELEC ATEX	CENELEC ATEX (KEMA) Flameproof Approval *1 Applicable Standard: EN 60079-0, EN 60079-1, EN 61241-0, EN 61241-1 Certificate: KEMA 07ATEX0109 II 2G, 2D Exd IIC T4, T5, T6 Ex tD A21 IP6X T85, T100, T120 Degree of protection : IP66 and IP67 Amb. Temp. (Tamb) for gas-proof : T4 ; -50 to 75°C (-58 to 167°F), T5; -50 to 80°C (-58 to 176°F), T6; -50 to 75°C (-58 to 167°F) Max. process Temp.(Tp): T4; 120°C (248°F), T5; 100°C (212°F), T6; 85°C (185°F) Max. surface Temp. for dust-proof : T85°C (Tamb: -40 to 40°C, Tp:85°C), T100°C (Tamb: -40 to 60°C, Tp:100°C), T120°C (Tamb: -40 to 80°C, Tp:120°C)	KF21
	CENELEC ATEX (KEMA) Intrinsically safe Approval *1*2 Applicable Standard: EN 50014, EN 50020, EN 50284, EN 50281-1-1 Certificate: KEMA 03ATEX1544X II 1G, 1D EEx ia IIC T4 Degree of protection : IP66 and IP67 Amb. Temp.(Tamb) for gas-proof: -50 to 60°C (-58 to 140°F) Maximum Process Temp.(Tp) for gas-proof :120°C Electrical data : Ui=30 V, li=200 mA, Pi=0.9 W, Ci=10 nF, Li=0 mH Max. surface Temp. for dust-proof : T85°C (Tamb: -40 to 60°C, Tp:80°C), T100°C (Tamb: -40 to 60°C, Tp:100°C), T120°C (Tamb: -40 to 60°C, Tp:120°C)	KS2
	Combined KF21, KS2 and Type n *1*2 Type n Applicable Standard: EN 60079-15 Referential Standard: IEC60079-0, IEC60079-11 II 3G Ex nL IIC T4, Amb. Temp.: -50 to 60°C (-50 to 140°F) Ui=30 V DC, Ci=10 nF, Li=0 mH	KU21

T05E.EPS

*1: Applicable for Electrical connection code **2, 4, 7, 9, C and D**.

*2: Not applicable for option code **/AL**.

Item	Description	Code
Canadian Standards Association (CSA)	<p>CSA Explosionproof Approval *1 Certificate: 2014354 Applicable Standard: C22.2 No.0, C22.2 No.0.4, C22.2 No.0.5, C22.2 No.25, C22.2 No.30, C22.2 No.94, C22.2 No.60079-0, C22.2 No.60079-1, C22.2 No.61010-1-01 Explosion-proof for Class I, Groups B, C and D. Dustignition-proof for Class II/III, Groups E, F and G. When installed in Division 2, "SEAL NOT REQUIRED" Enclosure: TYPE 4X, Temp. Code: T6...T4 Ex d IIC T6...T4 Enclosure: IP66 and IP67 Max.Process Temp.: T4;120°C(248°F), T5;100°C(212 °F), T6; 85°C(185°F) Amb.Temp.: -50 to 75°C(-58 to 167°F) for T4, -50 to 80°C(-58 to 176°F) for T5, -50 to 75°C(-58 to 167°F) for T6</p>	CF1
	<p>CSA Intrinsically safe Approval *1*2 Certificate: 1606623 [For CSA C22.2] Applicable Standard: C22.2 No.0, C22.2 No.0.4, C22.2 No.25, C22.2 No.94, C22.2 No.154, C22.2 No.213, C22.2 No.1010.1 Intrinsically Safe for Class I, Division 1, Groups A, B, C & D, Class II, Division 1, Groups E, F & G, Class III, Division 1, Nonincendive for Class I, Division 2, Groups A, B, C & D, Class II, Division 2, Groups E, F & G, Class III, Division 1 Enclosure: Type 4X, Temp. Code: T4 Amb. Temp.: -50 to 60°C(-58 to 140°F) Electrical Parameters: [Intrinsically Safe] Vmax=30V, Imax=200mA, Pmax=0.9W, Ci=10nF, Li=0 [Nonincendive] Vmax=30V, Ci=10nF, Li=0 [For CSA E60079] Applicable Standard: CAN/CSA E60079-0, CAN/CSA E60079-11, CAN/CSA E60079-15, IEC 60529:2001-02 Ex ia IIC T4, Ex nL IIC T4 Enclosure: IP66 and IP67 Amb. Temp.: -50 to 60°C(-58 to 140°F), Max. Process Temp.: 120°C(248°F) Electrical Parameters: [Ex ia] Ui=30V, li=200mA, Pi=0.9W, Ci=10nF, Li=0 [Ex nL] Ui=30V, Ci=10nF, Li=0</p>	CS1
	Combined CF1 and CS1 *1*2	CU1
IECEX Scheme *3	<p>IECEX Flameproof Approval *1 Applicable Standard: IEC 60079-0:2004, IEC60079-1:2003 Certificate: IECEX CSA 07.0008 Flameproof for Zone 1, Ex d IIC T6...T4 Enclosure: IP66 and IP67 Max.Process Temp.: T4;120°C(248°F), T5;100°C(212°F), T6; 85°C(185°F) Amb.Temp.: -50 to 75°C(-58 to 167°F) for T4, -50 to 80°C(-58 to 176°F) for T5, -50 to 75°C(-58 to 167°F) for T6</p>	SF2
	<p>IECEX Intrinsically safe, type n and Flameproof Approval *1*2 Intrinsically safe and type n Applicable Standard: IEC 60079-0:2000, IEC 60079-11:1999, IEC 60079-15:2001 Certificate: IECEX CSA 05.0005 Ex ia IIC T4, Ex nL IIC T4 Enclosure: IP66 and IP67 Amb. Temp.: -50 to 60°C(-58 to 140°F), Max. Process Temp.: 120°C(248°F) Electrical Parameters: [Ex ia] Ui=30V, li=200mA, Pi=0.9W, Ci=10nF, Li=0 [Ex nL] Ui=30V,Ci=10nF, Li=0 Flameproof Applicable Standard: IEC 60079-0:2004, IEC60079-1:2003 Certificate: IECEX CSA 07.0008 Flameproof for Zone 1, Ex d IIC T6...T4 Enclosure: IP66 and IP67 Max.Process Temp.: T4;120°C(248°F), T5;100°C(212°F), T6; 85°C(185°F) Amb.Temp.: -50 to 75°C(-58 to 167°F) for T4, -50 to 80°C(-58 to 176°F) for T5, -50 to 75°C(-58 to 167°F) for T6</p>	SU2
Combination of approval	Combination of KU21, FU1 and CU1 *1*2	V1U

*1: Applicable for Electrical connection code **2, 4, 7, 9, C** and **D**.
 *2: Not applicable for option code **/AL**.
 *3: Applicable only for Australia, New Zealand, Singapore and India.

T05Eb.EPS

OPTIONAL SPECIFICATIONS

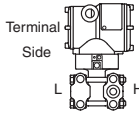
Item		Description	Code	
Painting	Color change	Amplifier cover only ^{*1}	P□	
		Amplifier cover and terminal cover, Munsell 7.5 R4/14 ^{*1}	PR	
	Coating change	Anti-corrosion coating ^{*1,2}	X2	
316 SST exterior parts		316 SST name plate, tag plate and zero-adjustment screw ^{*11}	HC	
Lightning protector		Transmitter power supply voltage: 10.5 to 32 V DC (10.5 to 30 V DC for intrinsically safe type) Allowable current: Max. 6000 A (1×40 μs), Repeating 1000 A (1×40 μs) 100 times Applicable Standards: IEC 61000-4-4, IEC 61000-4-5	A	
Status output ^{*4}		Transistor output (sink type) Contact rating : 10.5 to 30 V DC, 120 mA DC(max) Low level : 0 to 2 V DC	AL	
Oil-prohibited use ^{*5}		Degrease cleansing treatment	K1	
		Degrease cleansing treatment with fluorinated oilfilled capsule. Operating temperature -20 to 80°C (-4 to 176°F)	K2	
Oil-prohibited use ^{*5} with dehydrating treatment		Degrease cleansing and dehydrating treatment	K5	
		Degrease cleansing and dehydrating treatment with fluorinated oilfilled capsule. Operating temperature -20 to 80°C (-4 to 176°F)	K6	
Capsule fill fluid		Flourinated oil filled in capsule Operating temperature -20 to 80°C (-4 to 176°F)	K3	
Calibration units ^{*6}		P calibration (psi unit)	(See Table for Span and Range Limits.)	
		bar calibration (bar unit)		
		M calibration (kgf/cm ² unit)		
Long vent ^{*7}		Total length: 119 mm (standard: 34 mm); Total length when combining with Optional code K1, K2, K5, and K6: 130 mm. Material: 316SST.	U1	
Gold-plated capsule gasket ^{*13}		Gold-plated 316L SST capsule gasket. Without drain and vent plugs.	GS	
Output limits and failure option ^{*8}		Output status at CPU failure and hardware error. When combining with Optional code F1, output signal is -5%, 3.2 mA DC or less.	C1	
		NAMUR NE43 Compliant Output signal limits : 3.8mA to 20.5 mA	Failure alarm down-scale : Output status at CPU failure and hardware error is -5%, 3.2mA DC or less. Failure alarm up-scale : Output status at CPU failure and hardware error is 110%, 21.6 mA or more.	C2 C3
		130 Pa abs (1 mmHg abs) Calibration ^{*12}	Minimum input pressure: 130 Pa abs(1 mmHg abs) at range calibrating testing	S1
Body option ^{*9}		Without drain and vent plugs	N1	
		N1 and Process connection, based on IEC61518 with female thread on both sides of cover flange, with blind kidney flanges on back	N2	
		N2, and Material certificate for cover flange, diaphragm, capsule body, and blind kidney flange	N3	
Stainless steel tag plate		304 SST tag plate wired onto transmitter (316 SST when /HC is specified)	N4	
Data Configuration at factory ^{*10}		Data configuration for HART communication type	Software damping, Descriptor, Message	
		Data configuration for BRAIN communication type	Software damping	
Advanced diagnostics ^{*14}		Multi-sensing process monitoring • Impulse line blockage detection ^{*15} • Heat trace monitoring	DG6	

T06E.EPS

- *1: Not applicable for amplifier housing code **0**.
- *2: Not applicable with color change option.
- *4: When this option code is specified, check terminals are not available. Not applicable for output signal code **F**.
- *5: Applicable for wetted parts material code **S**.
- *6: The unit of MWP (Max. working pressure) on the name plate of a housing is the same unit as specified by option code **D1, D3, and D4**.
- *7: Applicable for vertical impulse piping type (Installation code 7) Long vent material is 316 SST.
- *8: Applicable for output signal code **D** and **E**. The hardware error indicates faulty amplifier or capsule.
- *9: Applicable for wetted parts material code **S**, process connection code **3, 4, and 5**; Installation code **9**; and mounting bracket code **N**. Process connection faces on the other side of zero adjustment screw.
- *10: Also see 'Ordering Instructions'.
- *11: 316 or 316L SST. The specification is included in amplifier code **2**.
- *12: Applicable for Capsule code **M** and **A** with upper range value smaller than 53.3 kPa (400 mmHg abs) .
If not specified, minimum input pressure for calibration testing will be 2.7 kPa abs (20 mmHg abs) even if the smaller range value is specified for customer's range.
- *13: Applicable for wetted parts material code **S**; process connection code **0** and **5**; and installation code **8** and **9**. Not applicable for option code **U1, N2, N3** and **M11**. No PTFE is used for wetted parts.
- *14: Applicable only for output signal code **-E**.
- *15: The change of pressure fluctuation is monitored and then detects the impulse line blockage.
See TI 01C25A31-01E for detailed technical information required for using this function.

Item	Description		Code
Material Certificate*1	Cover flange *3		M01
	Cover flange, Process connector *4		M11
Pressure test/ Leak test Certificate*2	Test Pressure: 50kPa (200 inH ₂ O)*5	Nitrogen(N ₂) Gas*8	T04
	Test Pressure: 3.5MPa (500 psi)*6		T01
	Test Pressure: 16 MPa (2300 psi)*7	Retention time: one minute	T12

T08E.EPS

- *1: Material traceability certification per EN 10204 3.1B.
- *2: The unit on the certificate is always Pa unit regardless of selection of option code **D1**, **D3** or **D4**.
- *3: Applicable for Process connections code **0** and **5**.
- *4: Applicable for Process connections code **1**, **2**, **3**, and **4**.
- *5: Applicable for capsule code **M** and **L**.
- *6: Applicable for capsule code **A**.
- *7: Applicable for capsule code **B**.
- *8: Pure nitrogen gas is used for oil-prohibited use (option codes **K1**, **K2**, **K5**, and **K6**.)

DIMENSIONS

● Vertical Impulse Piping Type (INSTALLATION CODE '7') (For code '3', refer to the notes below.)

Unit : mm (approx.inch)

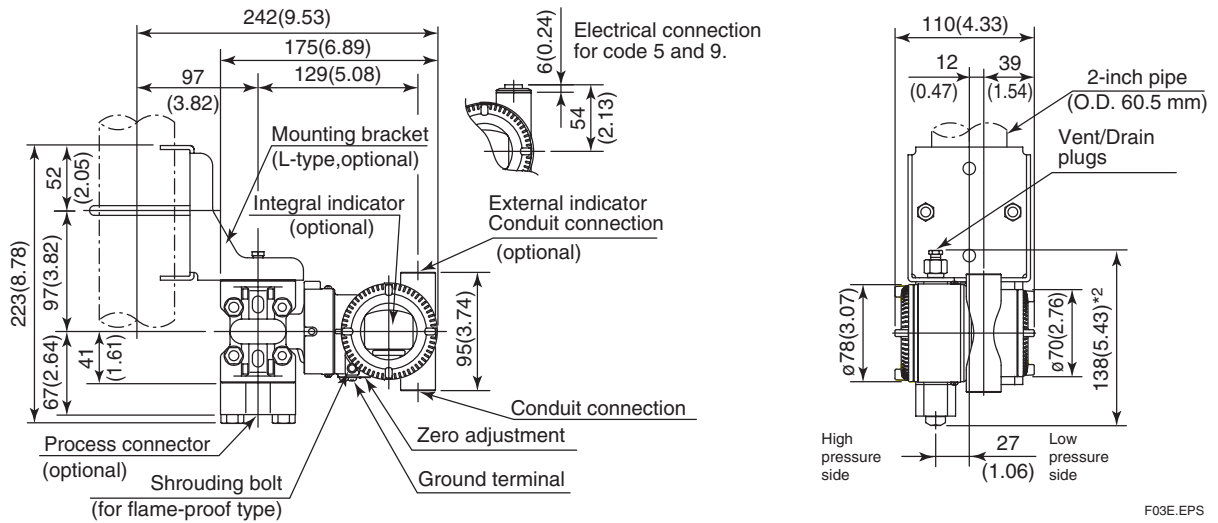

F03E.EPS

● Horizontal Impulse Piping Type (INSTALLATION CODE '9') (For CODE '8', refer to the notes below.)

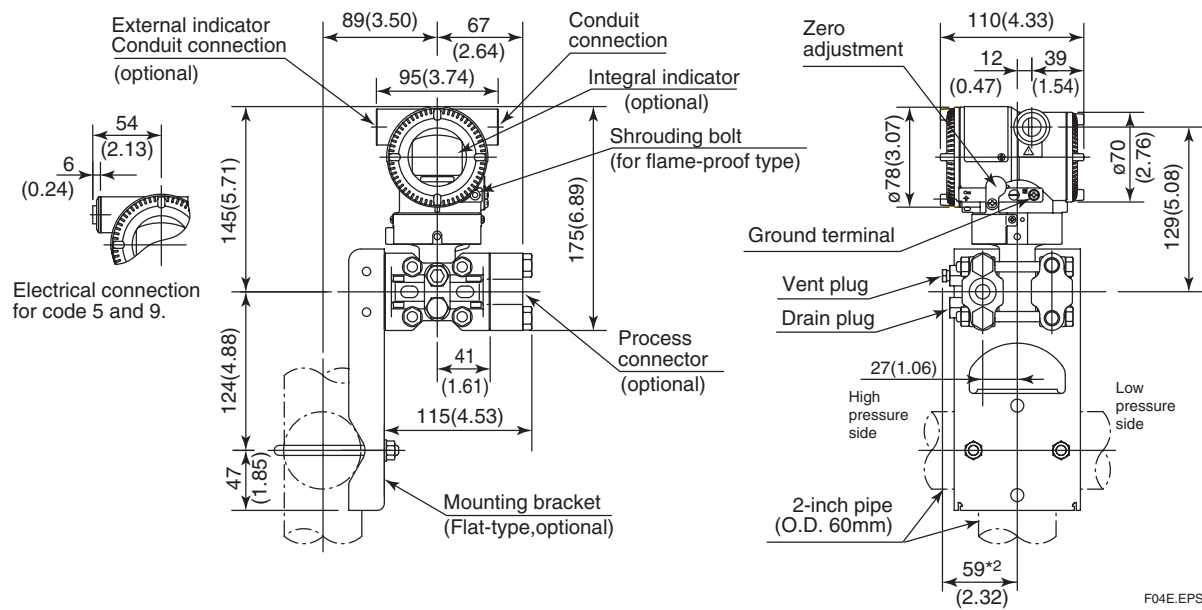

F04E.EPS

- * 1: When Installation code 3 or 8 is selected, high and low pressure side on above figure are reversed. (i.e. High pressure side is on the right side.)
- * 1: When option code K1, K2, K5 or K6 is specified, add 15mm(0.59 inch) to the value in the figure.

● **Universal Flange (INSTALLATION CODE 'U')**

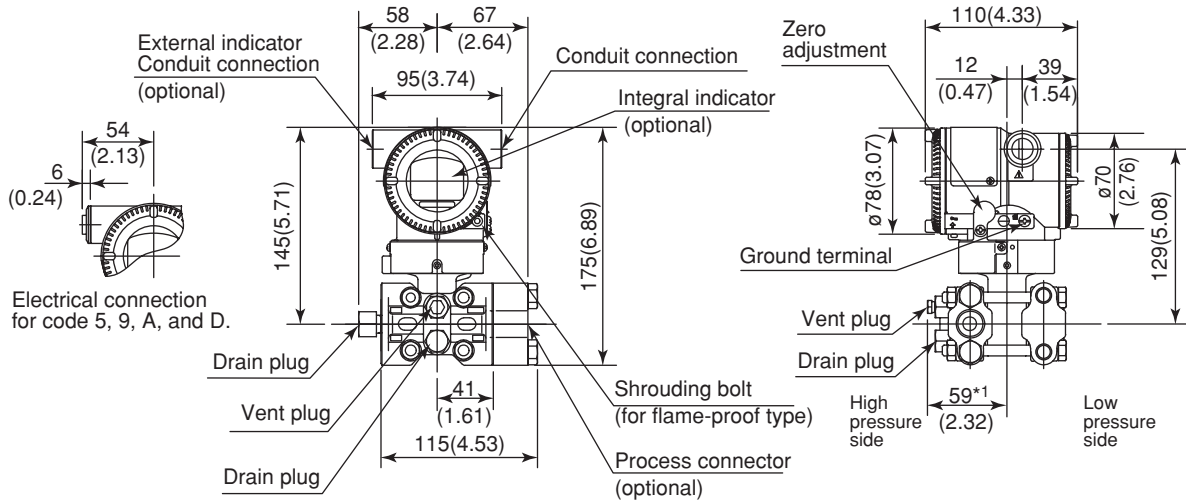

*1: When Option code K1, K2, K5, or K6 is selected, add 15 mm(0.59 inch) to the value.

● **Bottom Process Connection Type (INSTALLATION CODE 'B')**

Unit : mm (approx.inch)

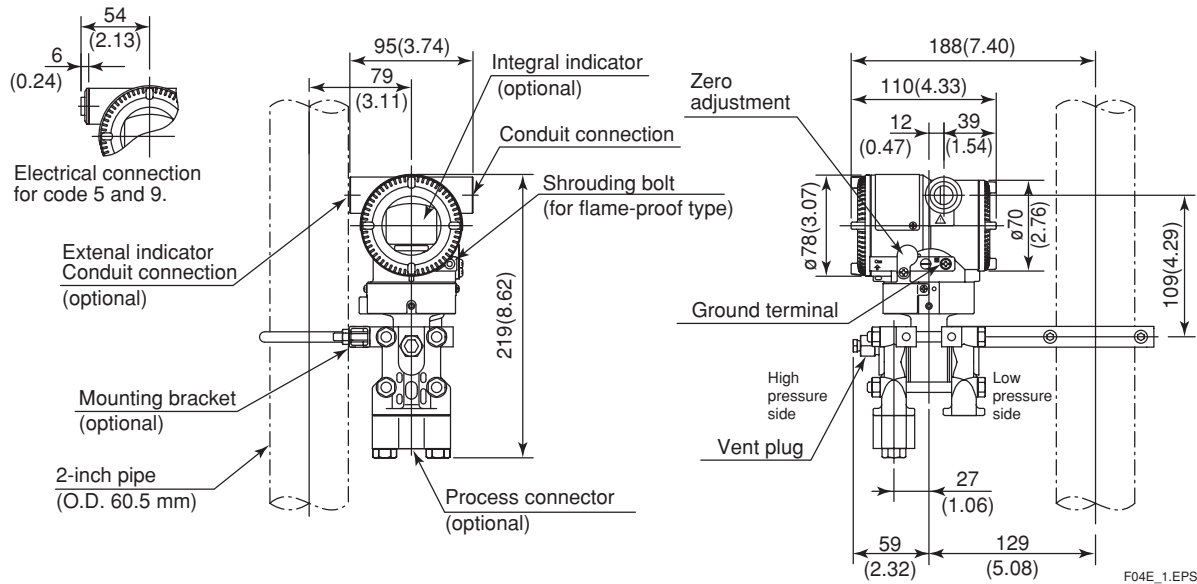

F04E_1.EPS

● Terminal Configuration

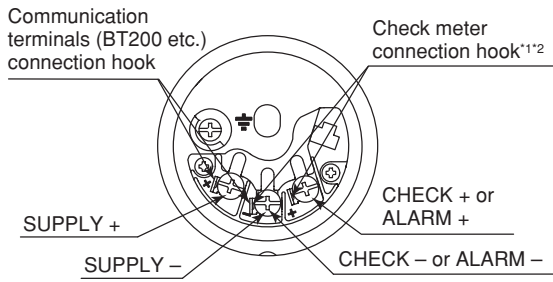

● Terminal Wiring

SUPPLY	+ -	Power supply and output terminal
CHECK or ALARM	+ -	External indicator (ammeter) terminal ^{*1*2} or Status contact output terminal ^{*2} (when /AL is specified)
		Ground terminal

*1: When using an external indicator or check meter, the internal resistance must be 10 Ω or less. A check meter or indicator cannot be connected when /AL option is specified.
*2: Not available for fieldbus communication type.

F05E.EPS

● Wiring Example for Analog Output and Status Output

Connection	Description
<p>Analog output</p>	<p>EJX electrical terminal</p> <p>Distributor</p> <p>24V DC</p> <p>250Ω</p>
<p>Analog and status output (when /AL is specified)</p> <p>If shield cable is not used, communication is not possible.</p>	<p>EJX electrical terminal</p> <p>Shielded cable</p> <p>Distributor</p> <p>24V DC</p> <p>250Ω</p> <p>External power supply 30V DC, 120mA max</p> <p>AC power supply</p> <p>Magnetic valve</p> <p>Use two-wire separately shielded cables.</p>

F06E.EPS

< Ordering Information > “◇”

Specify the following when ordering

1. Model, suffix codes, and option codes
2. Calibration range and units:
 - 1) Calibration range can be specified with range value specifications up to 5 digits (excluding any decimal point) for low or high range limits within the range of -32000 to 32000. When reverse range is designated, specify Lower Range Value(LRV) as greater than Upper Range Value(URV).
 - 2) Specify only one unit from the table, 'Factory Setting'.
3. Display scale and units (for transmitters equipped with an integral indicator only)

Specify either 0 to 100% or engineering unit scale and 'Range and Unit' for engineering units scale: Scale range can be specified with range limit specifications up to 5 digits (excluding any decimal point) for low or high range limits within the range of -32000 to 32000. Unit display consists of 6-digit, therefore, if specified unit excluding '/' is longer than 6 characters, the first 6 characters will be displayed on the unit display.
4. Tag Number (if required).

For BRAIN communication type, specify upto 16 letters. The specified letters will be written in the amplifier memory and engraved on the tag plate. For HART communication type, specify software tag (upto 8 letters) to be written on the amplifier memory and Tag number(upto 16 letters) to be engraved on the tag plate seperately.
5. Other factory configurations (if required)

Specifying option code **CA** or **CB** will allow further configuration at factory. Following are configurable items and setting range.

[/CA: For HART communication type]

 - 1) Descriptor(upto 16 characters)
 - 2) Message (upto 30 characters)
 - 3) Software damping in second(0.00 to 100.00)

[/CB: For BRAIN communication type]

 - 1) Software damping in second(0.00 to 100.00)

< Factory Setting > “◇”

Tag number	As specified in order
Software damping *1	'2.00 sec' or as specified in order
Calibration range lower range value	As specified in order
Calibration range upper range value	As specified in order
Calibration range units	Selected from torr, Pa abs *2, hPa abs *2, kPa abs, MPa abs, mbar abs, bar abs, mmH ₂ O abs, mmH ₂ O(68°F) abs, mmHg abs, gf/cm ² abs, kgf/cm ² abs, inH ₂ O abs, inH ₂ O abs(68°F), inHg abs, ftH ₂ O abs, ftH ₂ O abs(68°F), atm, or psia. (Only one unit can be specified)
Display setting	Designated value specified in order. (% , or user scaled value.)

*1: To specify this item at factory, option code **CA** or **CB** is required.

*2: Not available for HART protocol type.

T07E.EPS