

The YTA310 and YTA320 are the highly accurate temperature transmitters that accept Thermocouple, RTD, ohms or DC millivolts inputs and converts it to a 4 to 20 mA DC signal for transmission. The YTA310 is a single sensor input model, and the YTA320 is a dual input model. Both models support either BRAIN or HART® communication protocol, and YTA320 also supports FOUNDATION fieldbus™.

The YTA310/320 in their standard configuration, with the exception of the Fieldbus type, are certified by TÜV as complying with SIL 2 for safety requirement.

For the specifications of Fieldbus communication type marked with “◇”, refer to GS 1C50T2-E.



### ■ FEATURES

#### Outstanding performance

Microprocessor-based sensing technology ensures high accuracy and reliability.

#### High reliability

Dual-compartment housing realizes high resistance capability to harsh environments and the YTA310/320 have SIL2 capability for safety requirement.

#### Variety of sensor inputs

The type of sensor input is user-selectable from thermocouples (T/C), RTDs, ohms, or DC millivolts.

#### Digital communication

BRAIN or HART® communication protocol is available. The instrument configuration can be changed by the user with using the BT200 or HART® communicator.

#### Self-diagnostics function

Continuous self-diagnostics capability ensures long-term performance and lower cost of ownership.

#### LCD display with bargraph

The LCD display provides both a digital readout and percent bargraph simultaneously.

#### Dual universal inputs (Model YTA320)

The YTA320 can accept two thermocouple, RTD, ohm or DC millivolt inputs. Differential or average temperature measurement is selectable. The sensor backup function for automatically switches-over from the primary to the backup upon sensor failure.

### ■ STANDARD SPECIFICATIONS

#### □ PERFORMANCE SPECIFICATIONS

##### Accuracy

BRAIN, HART communication type:  
A/D accuracy/span + D/A accuracy  
(See Table 1 on page 3.)

Fieldbus communication type:

A/D accuracy  
(See Table 1 on page 3.)

##### Cold Junction Compensation Accuracy

(For T/C only)  
 $\pm 0.5^{\circ}\text{C}$  ( $\pm 0.9^{\circ}\text{F}$ )

##### Ambient Temperature Effect

BRAIN, HART communication type:  
Sum of temperature coefficient of A/D conversion and D/A conversion. (See Table 2 on page 4.)

Fieldbus communication type:  
Coefficient of A/D conversion. (See Table 2 on page 4.)

##### Stability

RTD:  
 $\pm 0.1\%$  of reading or  $\pm 0.1^{\circ}\text{C}$  per 2 years,  
whichever is greater at  $23\pm 2^{\circ}\text{C}$ .

T/C:  
 $\pm 0.1\%$  of reading or  $\pm 0.1^{\circ}\text{C}$  per year,  
whichever is greater at  $23\pm 2^{\circ}\text{C}$ .

##### 5 Year Stability

RTD:  
 $\pm 0.2\%$  of reading or  $\pm 0.2^{\circ}\text{C}$ ,  
whichever is greater at  $23\pm 2^{\circ}\text{C}$ .

T/C:  
 $\pm 0.4\%$  of reading or  $\pm 0.4^{\circ}\text{C}$ ,  
whichever is greater at  $23\pm 2^{\circ}\text{C}$ .

##### Vibration Effect

10 to 60 Hz 0.21 mm peak displacement  
60 to 2000 Hz 3G

##### RFI Effect

Tested per EN 50082-2, field intensity up to 10 V/m.

##### Power Supply Effect

$\pm 0.005\%$  of calibrated span per volt

##### Position Effect

None

#### □ FUNCTIONAL SPECIFICATIONS

##### Input

YTA310: single input, YTA320: dual input  
Input type is selectable: Thermocouples, 2-, 3-, and 4-wire RTDs, ohms and DC millivolts. See Table 1. on page 3.

##### Span & Range Limits

See Table 1. on page 3.

**Input signal source resistance (for T/C, mV)**1 k $\Omega$  or lower**Input lead wire resistance (for RTD, ohm)**10  $\Omega$  per wire or lower**Output “◇”**

Two wire 4 to 20 mA DC.

Output range: 3.68 to 20.8 mA

BRAIN or HART<sup>®</sup> protocol is superimposed on the 4 to 20 mA signal.

Any single value among followings can be selected as the analog output signal.

Sensor 1, Terminal Temperature.

For YTA320, same as above plus;

Sensor 2, Average, and Differential Temperature.

Also, up to three of the above values can be displayed on LCD display or read via communication.

**Isolation**

Input/Output/GND isolated to 500V DC

**Manual Output Function**

The output value can be set manually.

**Sensor Burnout (Output signal code D & E)**

High (21.6 mA DC) or low (3.6 mA DC), user-selectable.

**Output in Transmitter Failure (Output signal code D & E)**

Up-scale: 110%, 21.6 mA DC or more (Standard or Optional code /C3)

Down-scale: -5%, 3.2 mA DC or less (Optional code /C1 or /C2)

**Update Time (Output signal code D & E)**

Approximately 0.5 seconds for a single sensor (0.8 second for dual sensors)

**Turn-on Time (Output signal code D & E)**

Approximately 5 seconds

**Damping Time Constant**

Selectable from 0 to 99 seconds

**Ambient Temperature Limits**

Option Code may affect limits.

-40 to 85°C (-40 to 185°F)

-30 to 80°C (-22 to 176°F) with Integral Indicator

**Ambient Humidity Limits**

5 to 100% RH at 40°C (104°F)

**EMC Conformity Standards**  , 

EN61326, AS/NZS CISPR11

**SIL Certification**

YTA310/320 temperature transmitters except

Fieldbus communication type are certified by TÜV

NORD CERT GmbH in compliance with the following standards;

IEC 61508: 2000; Part1 to Part 7 Functional Safety of Electrical/electronic/programmable electronic related systems;

SIL 2 capability for single transmitter use, SIL 3 capability for dual transmitter use.

**Self-diagnostics**

Loss of input error, ambient temperature error, EEPROM error, and CPU error.

**Sensor Back-up Function (Model YTA320)**

The YTA320 can be set to automatically switch to Sensor 2 when Sensor 1 fails, and not “bump” the output signal.

**Sensor Matching Function**

Callender-vanDusen coefficient of specific RTD can be programmed into a transmitter to improve total measurement accuracy.

**Supply & Load Requirements****Supply Voltage “◇”**10.5 to 42 V DC for general use and flameproof type  
10.5 to 32 V DC for lightning protector (Optional code /A)10.5 to 30 V DC for intrinsically safe, Type n, nonincendive, or non-sparking type  
Minimum voltage limited at 16.4 V DC for digital communications, BRAIN and HART<sup>®</sup> protocols**Load (Output signal code D & E)**0 to 1335  $\Omega$  for operation250 to 600  $\Omega$  for digital communication

See Figure 1. on page 4.

**Communication Requirements “◇”****BRAIN:****Communication Distance**

Up to 2 km (1.25 miles) when using CEV polyethylene-insulated PVC-sheathed cables. Communication distance varies depending on type of cable used.

**Load Capacitance**0.22  $\mu$ F or less**Load Inductance**

3.3 mH or less

**Input Impedance of communicating device**10 k $\Omega$  or more at 2.4 kHz. **PHYSICAL SPECIFICATIONS****Enclosure****Material**

Low copper cast-aluminum alloy

**Coating**

Polyurethan resin baked finish

Color: Deep-sea moss green (Munsell 0.6GY3.1/2.0)

**Degrees of Protection**

IP67, NEMA4X, JIS C0920 immersion proof

**Data and Tag Plate**

SUS304 Stainless steel

**Mounting**

Optional mounting brackets can be used either for two-inch pipe or flat panel mounting.

**Terminal Screws**

M4 screws

**Integral Indicator**

Optional LCD digital indicator includes 5-digit numerical display with °C, K, °F, °R, % and mV, 0 to 100% bargraph and dot-matrix display.

**Weight**

1.2 kg(2.6 lb) without integral indicator and mountingbracket. Integral indicator weights 0.2 kg(0.4 lb).

**Electrical Connections**

Refer to 'MODEL AND SUFFIX CODES.'

**Table 1. Sensor type, range, and accuracy.**

Sensor Type	Reference Standard	Measurement Range		Minimum Span (Recommended)	Accuracy				D/A Accuracy	
		°C	°F		Input range		A/D Accuracy			
					°C	°F	°C	°F		
T/C	IEC584	B	100 to 1820	212 to 3308	25 °C (45 °F)	100 to 300	212 to 572	± 3.0	± 5.4	±0.02% of span
						300 to 400	572 to 752	± 1.0	± 1.8	
		400 to 1820	752 to 3308	± 0.75		± 1.35				
		E	-200 to 1000	-328 to 1832		-200 to -50	-328 to -58	± 0.35	± 0.63	
						-50 to 1000	-58 to 1832	± 0.16	± 0.29	
		J	-200 to 1200	-328 to 2192		-200 to -50	-328 to -58	± 0.40	± 0.72	
						-50 to 1200	-58 to 2192	± 0.20	± 0.36	
		K	-200 to 1372	-328 to 2502		-200 to -50	-328 to -58	± 0.50	± 0.90	
	-50 to 1372					-58 to 2502	± 0.25	± 0.45		
	N	-200 to 1300	-328 to 2372	-200 to -50		-328 to -58	± 0.80	± 1.44		
				-50 to 1300		-58 to 2372	± 0.35	± 0.63		
	R	ASTM E988	-50 to 1768	-58 to 3214		-50 to 0	-58 to 32	± 1.0	± 1.8	
						0 to 100	32 to 212	± 0.80	± 1.44	
						100 to 600	212 to 1112	± 0.60	± 1.08	
600 to 1768					1112 to 3214	± 0.40	± 0.72			
S	DIN43710	-50 to 1768	-58 to 3214	-50 to 0	-58 to 32	± 1.0	± 1.8			
				0 to 100	32 to 212	± 0.80	± 1.44			
				100 to 600	212 to 1112	± 0.60	± 1.08			
				600 to 1768	1112 to 3214	± 0.40	± 0.72			
T	ASTM E988	-200 to 400	-328 to 752	-200 to -50	-328 to -58	± 0.25	± 0.45			
				-50 to 400	-58 to 752	± 0.14	± 0.25			
W3	ASTM E988	0 to 2300	32 to 4172	0 to 400	32 to 752	± 0.80	± 1.44			
				400 to 1400	752 to 2552	± 0.50	± 0.90			
				1400 to 2000	2552 to 3632	± 0.60	± 1.08			
				2000 to 2300	3632 to 4172	± 0.90	± 1.62			
				0 to 400	32 to 752	± 0.70	± 1.26			
				400 to 1400	752 to 2552	± 0.50	± 0.90			
W5	DIN43710	0 to 2300	32 to 4172	1400 to 2000	2552 to 3632	± 0.70	± 1.26			
				2000 to 2300	3632 to 4172	± 0.90	± 1.62			
				-200 to -50	-328 to -58	± 0.30	± 0.54			
				-50 to 900	-58 to 1652	± 0.20	± 0.36			
L	DIN43710	-200 to 900	-328 to 1652	-200 to -50	-328 to -58	± 0.50	± 0.90			
				-50 to 600	-328 to 1112	± 0.25	± 0.45			
RTD	IEC751	-200 to 850	-328 to 1562	10 °C (18 °F)	-200 to 850	-328 to 1562	± 0.14 (± 0.10)*	± 0.25 (± 0.18)*		
					-200 to 850	-328 to 1562	± 0.30 (± 0.22)*	± 0.54 (± 0.40)*		
	Pt500	JIS C1604	-200 to 850		-328 to 1562	-200 to 850	-328 to 1562	± 0.20 (± 0.14)*	± 0.36 (± 0.25)*	
						-200 to 500	-328 to 932	± 0.16 (± 0.10)*	± 0.29 (± 0.18)*	
	Cu	SAMA RC21-4	-70 to 150		-94 to 302	-70 to -40	-94 to -40	± 1.35	± 2.43	
						-40 to 150	-40 to 302	± 1.0	± 1.8	
Ni120	—	-70 to 320	-94 to 608	-70 to 320	-94 to 608	± 0.11 (± 0.08)*	± 0.20 (± 0.14)*			
mV	—	-10 to 100 [mV]		3 [mV]	—		± 12 [μV]			
ohm	—	0 to 2000 [Ω]		20 [Ω]	—		± 0.35 [Ω]			

Note 1: A/D accuracy marked with ( )\* in the above table is an accuracy for Fieldbus communication type.

T01E.EPS

Note 2: For BRAIN/HART communication type, Total Accuracy = (A/D Accuracy/Span + D/A Accuracy)

For T/C input, add Cold Junction Compensation Accuracy (± 0.5°C) to the total accuracy.

Example; when selecting Pt100 with measurement range of 0 to 200°C.

$$\frac{0.14^{\circ}\text{C}}{200^{\circ}\text{C}} \times 100\% \text{ of span} + 0.02\% \text{ of span} = \pm 0.09\% \text{ of span}$$

Note 3: For differential or average measurement of YTA320, the digital accuracy is as followsings ;

<When the types of the sensors are similar (for example, T/C & T/C, RTD & RTD )>

A/D accuracy = A/D accuracy of either two input, whichever is worse × 1.5

<When the types of the sensors are dissimilar(for example, T/C & RTD )>

A/D accuracy = Sensor 1 A/D accuracy + Sensor 2 A/D accuracy

**Table 2. Temperature Coefficient.**

Sensor Type	Input Range		A/D Coefficient		D/A Coefficient
	°C	°F			
T/C	B	100 to 300	212 to 572	± (0.530 °C-0.080 % of reading)	
		300 to 1000	572 to 1832	± (0.350 °C-0.021 % of reading )	
		1000 to 1820	1832 to 3308	± (0.140 °C)	
	E	-200 to 1000	-328 to 1832	± (0.035 °C+0.042 % of abs.reading)	
		-200 to 0	-328 to 32	± (0.039 °C+0.020 % of abs.reading)	
	J	0 to 1200	32 to 2192	± (0.039 °C+0.0029 % of reading)	
		-200 to 0	-328 to 32	± (0.046 °C+0.020 % of abs.reading)	
	K	0 to 1372	32 to 2502	± (0.046 °C+0.0054 % of reading)	
		-200 to 0	-328 to 32	± (0.054 °C+0.010 % of abs.reading)	
	N	0 to 1300	32 to 2372	± (0.054 °C+0.0036 % of reading)	
		-50 to 200	-58 to 392	± (0.210 °C-0.032 % of abs.reading)	
	R	200 to 1768	392 to 3214	± (0.150 °C)	
		-50 to 200	-58 to 392	± (0.210 °C-0.032 % of abs.reading)	
	S	200 to 1768	392 to 3214	± (0.150 °C)	
-200 to 0		-328 to 32	± (0.046 °C-0.036 % of abs.reading)		
T	0 to 400	32 to 752	± (0.046 °C)		
	0 to 1400	32 to 2552	± (0.100 °C+0.0040 % of reading)		
W3	1400 to 2300	2552 to 4172	± (-0.130 °C+0.020 % of reading)		
	0 to 1400	32 to 2552	± (0.100 °C+0.0040 % of reading)		
W5	1400 to 2300	2552 to 4172	± (-0.120 °C+0.020 % of reading)		
	-200 to 0	-328 to 32	± (0.039 °C+0.020 % of abs.reading)		
L	0 to 900	32 to 1652	± (0.039 °C+0.0029 % of reading)		
	-200 to 0	-328 to 32	± (0.046 °C+0.036 % of abs.reading)		
U	0 to 600	32 to 1112	± (0.046 °C)		
	-200 to 850	-328 to 1562	± (0.047 °C+0.009 % of reading) [ ± ( 0.015 °C+0.005 % of reading)]*		
RTD	Pt100	-200 to 850	-328 to 1562	± (0.065 °C+0.012 % of reading) [ ± ( 0.023 °C+0.005 % of reading)]*	
	Pt200	-200 to 850	-328 to 1562	± (0.047 °C+0.009 % of reading) [ ± ( 0.015 °C+0.005 % of reading)]*	
	Pt500	-200 to 850	-328 to 1562	± (0.047 °C+0.009 % of reading) [ ± ( 0.015 °C+0.005 % of reading)]*	
	JPt100	-200 to 500	-328 to 932	± (0.047 °C+0.009 % of reading) [ ± ( 0.015 °C+0.005 % of reading)]*	
	Cu	-70 to 150	-94 to 302	± (0.320 °C+0.120 % of reading)	
	Ni120	-70 to 320	-94 to 608	± (0.016 °C+0.007 % of reading) [ ± ( 0.010 °C+0.005 % of reading)]*	
mV	—		± (0.001mV+0.0043 % of abs.reading)		
ohm	—		± (0.040 Ω+0.0088 % of reading)		

TO2E.EPS

Note 1: A/D Coefficient marked with [ \* ] in the above table is an coefficient for Fieldbus communication type.

Note 2: For BRAIN/HART communication type;

Temperature Effect = A/D coefficient + D/A coefficient (The data in the table is the coefficient per 10 °C change.)

Example 1; Pt100Ω, 0 to 200 °C calibration range, 50 °C reading  
 (0.047 °C + 50°C × 0.009%)+[200°C×0.0088%+(50-0)×0.007%]  
 = (0.047 °C + 0.0045 °C)+(0.0176 °C + 0.0035 °C )  
 = ± 0.0726 °C [ per 10 °C change ]

Example 2; T T/C, -100 to 100 °C calibration range, -50 °C reading  
 (0.046 °C+| -50 °C | × 0.036%)+[200°C×0.0088%+[-50-(-100)]×0.007%]  
 = (0.046 °C+0.018 °C)+(0.0176 °C+0.0035 °C )  
 = ± 0.0851 °C [ per 10 °C change ]

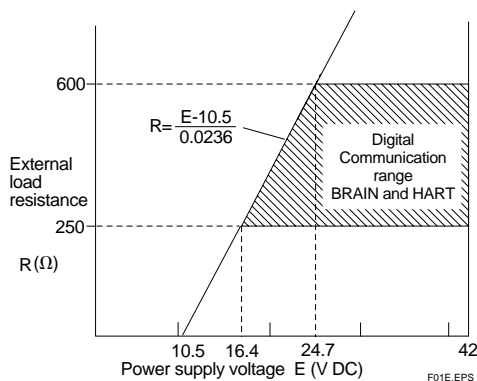

**Figure 1. Relationship Between Power Supply Voltage and External Load Resistance.**

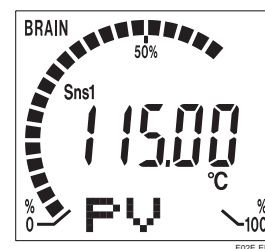

**Figure 2. Integral Indicator Display Example.**

## MODEL AND SUFFIX CODES

Model	Suffix Codes	Descriptions
<b>YTA310</b>	.....	Temperature Transmitter
<b>YTA320</b>	.....	Temperature Transmitter with Dual Sensor Input
Output Signal	<b>-D</b> .....	4 to 20mA DC with digital communication (BRAIN protocol)
	<b>-E</b> .....	4 to 20mA DC with digital communication (HART protocol, refer to GS 01C50T01-00E)
	<b>-F</b> .....	Digital communication (FOUNDATION Fieldbus protocol)*1
—	<b>A</b> .....	Always A
Electrical Connection	<b>0</b> .....	G1/2 female
	<b>2</b> .....	1/2 NPT female
	<b>3</b> .....	Pg 13.5 female
	<b>4</b> .....	M20 female
Integral Indicator	<b>D</b> .....	with digital indicator
	<b>N</b> .....	None
Mounting Bracket	<b>B</b> ....	SUS304 Stainless steel 2-inch horizontal pipe mounting *2
	<b>D</b> ....	SUS304 Stainless steel 2-inch vertical pipe mounting *2
	<b>N</b> ....	None
Optional Codes	/□ Optional Specifications	

\*1: Applicable only for YTA320, refer to GS 01C50T02-00E for Fieldbus communication.

T03E.EPS

\*2: For flat-panel mounting, please prepare bolts and nuts.

## OPTIONAL SPECIFICATIONS

Item	Descriptions	Code		
Lightning protector	Power supply voltage: 10.5 to 32 V DC (9 to 32 V DC for Fieldbus communication type.) Allowable current: Max. 6000A(1×40μs), repeating 1000A(1×40μs) 100 times	<b>A</b>		
Painting	Coating change	Epoxy resin coating	<b>X1</b>	
	Color change	Amplifier cover only	Munsell code: N1.5 Black	<b>P1</b>
			Munsell code: 7.5BG4/1.5, Jade green	<b>P2</b>
			Metallic silver	<b>P7</b>
	Amplifier and terminal Covers	Munsell code: 7.5 R4/14 Red	<b>PR</b>	
Calibration Unit	Degree F/Degree R unit	<b>D2</b>		
Output signal low-side in Transmitter failure *1	Output signal low-side: -5%, 3.2 mA DC or less. Sensor burnout is also set to 'LOW': -2.5%, 3.6 mA DC	<b>C1</b>		
NAMUR NE43 Compliant *1	Output signal limits: 3.8 mA to 20.5 mA	Failure alarm down-scale: output status at CPU failure and hardware error is -5%, 3.2 mA or less. Sensor burnout is also set to LOW: -2.5%, 3.6 mA DC.	<b>C2</b>	
		Failure alarm up-scale: output status at CPU failure and hardware error is 110%, 21.6 mA or more. In this case Sensor burnout is High: 110%, 21.6 mA DC.	<b>C3</b>	
Data Configuration	Description into "Descriptor" parameter of HART protocol (max. 16 characters)	<b>CA</b>		
Sensor matching function*2	RTD Sensor matching function	<b>CM1</b>		
Stainless steel housing *3	Housing Material: SCS14A stainless steel (equivalent to SUS316 cast stainless steel and ASTM CF-8M)	<b>E1</b>		

\*1: Not applicable for output signal code F.

\*2: Not necessary to specify when ordering output signal code F, as this function is already included.

\*3: Not applicable for optional code JF3, G11, G12, P1, P2, P7, PR, and X1.

T04E.EPS

## OPTIONAL SPECIFICATIONS (For Explosion Protected Types)

For FOUNDATION Fieldbus explosion protected type, see GS 01C50T02-00E

Item	Descriptions	Code
CENELEC ATEX (KEMA)	<p>CENELEC ATEX (KEMA) Intrinsically safe, Flameproof approval and Type n combination*3 [Intrinsically safe approval] Applicable standard: EN 50014, EN 50020, EN 50284 Certificate: KEMA 02ATEX1026X II 1G EEx ia IIC T4,T5 Ambient Temperature: -40 to 70°C for T4, -40 to 50°C for T5 Supply/Output circuit: Ui=30V, Ii=165mA, Pi=900mW, Ci=20nF, Li=660μH Input circuit: Uo=8.6V, Io=30mA, Po=70mW, Co=3μF, Lo=20mH Electrical Connection: 1/2 NPT female and M20 female*1</p> <p>[Flameproof and Dust Ignition Proof Approval] Applicable Standard: EN 60079-0, IEC 60079-1, EN 61241-0, EN 61241-1 Certificate: KEMA 07ATEX0130 II 2G Ex d IIC T6/T5, II 2D Ex tD A21 IP67 T70°C, T90°C Ambient Temperature for Gas Atmospheres: -40 to 75°C for T6, -40 to 80°C for T5 Ambient Temperature for Dust Atmospheres: -40 to 65°C for T70°C, -40 to 80°C for T90°C Enclosure: IP67 Electrical Connection: 1/2 NPT female and M20 female*1</p> <p>[Type n approval] Applicable standard: EN60079-15 Referential standard: IEC60079-0, IEC60079-11 II 3G EEx nL IIC T4, T5 Ambient Temperature: -40 to 70°C for T4, -40 to 50°C for T5 Supply/Output circuit: Ui=30V, Ci=20nF, Li=660μH Input circuit: Uo=8.6V, Io=30mA, Po=70mW, Co=3μF, Lo=20mH Electrical Connection: 1/2 NPT female and M20 female*1</p>	KU2
Canadian Standards Association (CSA)	<p>CSA Intrinsically safe, non-incendive and Explosionproof approval combination*3 [Intrinsically safe/non-incendive approval] Applicable standard: C22.2 No0, C22.2 No0.4, C22.2 No25, C22.2 No94, C22.2 No142, C22.2 No157, C22.2 No213 Certificate: 172608-0001053837 Intrinsically safe for Class I, Division 1, Groups A, B, C and D; Class II, Division 1, Groups E, F and G; Class III, Division 1: Non-incendive for Class I, Division 2, Groups A, B, C and D; Class II, Division 2, Groups E, F and G; Class III, Division 1: Enclosure Type 4X Temperature Class: T4, Ambient Temperature: -40 to 60°C, Supply: Vmax=30V, Imax=165mA, Pmax=0.9W, Ci=18nF, Li=730μH Sensor input: Voc=9V, Isc=40mA, Po=0.09W, Ca=1μF, La=10mH Electrical Connection: 1/2 NPT female*1</p> <p>[Explosionproof approval] Applicable standard: C22.2 No0, C22.2 No0.4, C22.2 No25, C22.2 No30, C22.2 No94, C22.2 No142, C22.2 No157, C22.2 No213, C22.2 No1010.1 Certificate: 1089576 Explosionproof Class I, Div.1, Groups B, C and D, Class II, Groups E, F and G, Class III. For Class I, Div.2 Locations "FACTORY SEALED, CONDUIT SEAL NOT REQUIRED" Enclosure Type 4X Temperature Class: T6 Ambient Temperature: -40 to 60°C Electrical Connection: 1/2 NPT female*2</p>	CU1
Factory Mutual (FM)	<p>FM Intrinsically safe, non-incendive and Explosionproof approval combination*3 [Intrinsically safe/non-incendive approval] Applicable standard: FM 3600, FM 3610, FM 3611, FM 3810 Intrinsically safe for Class I, II, III Division 1 Groups A, B, C, D, E, F and G. Non-incendive for Class I, II, Division 2 Groups A, B, C, D, E, F and G Class III, Division 1. Enclosure Type: 4X Temperature Class: T4 Ambient Temperature: -40 to 60°C (-40 to 140°F) Supply: Vmax=30V, Imax=165mA, Pmax=0.9W, Ci=18nF, Li=730μH Sensor: Voc=9V, Isc=40mA, Po=90mW, Ca=1μF, La=10mH</p> <p>[Explosionproof approval] Applicable standard: FM 3600, FM 3615, FM 3810, NEMA250 Class I, Division 1, Groups A, B, C and D.; Dust-ignitionproof for Class II/III, Division 1, Groups E, F and G. "FACTORY SEALED, CONDUIT SEAL NOT REQUIRED." Enclosure Ratings: NEMA4X Temperature Class: T6 Ambient Temperature: -40 to 60°C (-40 to 140°F) Electrical Connection: 1/2NPT female*2</p>	FU1
	<p>FM Explosionproof approval Applicable standard: FM 3600, FM 3615, FM 3810, NEMA250 Explosionproof Class I, Division 1, Groups A, B, C and D; Dust-ignitionproof for Class II/III, Division 1, Groups E, F and G. "FACTORY SEALED, CONDUIT SEAL NOT REQUIRED." Enclosure Rating: NEMA 4X Temperature Class: T6 Ambient Temperature: -40 to 60°C (-40 to 140°F) Electrical Connection: 1/2 NPT female*2</p>	FF1

\*1 : Applicable for Electrical Connection Code 2 and 4.

\*2 : Applicable for Electrical Connection Code 2.

\*3 : Not applicable for Output Signal Code F.

T05E-1.EPS

Item	Descriptions	Code	
Standards Association of Australia (SAA)	SAA Intrinsically safe, non-sparking and Flameproof approval combination [Intrinsically safe and non-sparking] Applicable standard: AS2380.1, AS2380.7, AS2380.9 Certificate: AUS Ex 3652X Ex ia IIC T4 (Tamb=70°C) IP66/67, Ex n IIC T4 (Tamb=70°C), IP66/67 Input parameters: Ui=30V, Ii=165mA, Pi=0.9W Output parameters: Uo=8.6V, Io=30mA, Po=62mW, Co=1µF [Flameproof approval] Applicable standard: AS2380.1, AS2380.2 Certificate: AUS Ex 3640 Ex d IIC T6 (Tamb=75°C) IP66/67 Electrical connection: 1/2 NPT female, Pg13.5 female and M20 female*5	SU1	
Japanese Industrial Standards (TIIS)	TIIS Flameproof approval Ex ds IIC T6 X                      Amb. Temp.: -20 to 60°C	JF3	
Attached flameproof packing adapter*4	Electrical connection: G1/2 female	1 pc.	G11
	Applicable cable: O.D. 8.5 to 11 mm	2 pc.	G12
IECEx Scheme*6	IECEx Flameproof and Dust ignition proof Approval Applicable Standard: IEC 60079-0, IEC 60079-1, IEC 61241-0, IEC 61241-1 Certificate: IECEx KEM 07.0044 Ex d IIC T6/T5, Ex tD A21 IP67 T70°C, T90°C Ambient Temperature for Gas Atmospheres -40 to 75°C (-40 to 167°F) for T6, -40 to 80°C (-40 to 176°F) for T5 Ambient Temperature for Dust Atmospheres: -40 to 65°C (-40 to 149°F) for T70°C, -40 to 80°C (-40 to 176°F) for T90°C Enclosure: IP67 Electrical Connection: 1/2 NPT female and M20 female	SF2	

T05E-2.EPS

\*4 : If cable wiring is to be used to a TIIS flameproof type transmitter, do not fail to add the YOKOGAWA-assured flameproof packing adapter.

\*5 : Applicable for Electrical connection code 2, 3 and 4.

\*6 : Applicable only for Australia, New Zealand area.

## DIMENSIONS

Unit: mm (Approx. inch)

### ● 2-inch horizontal pipe mounting

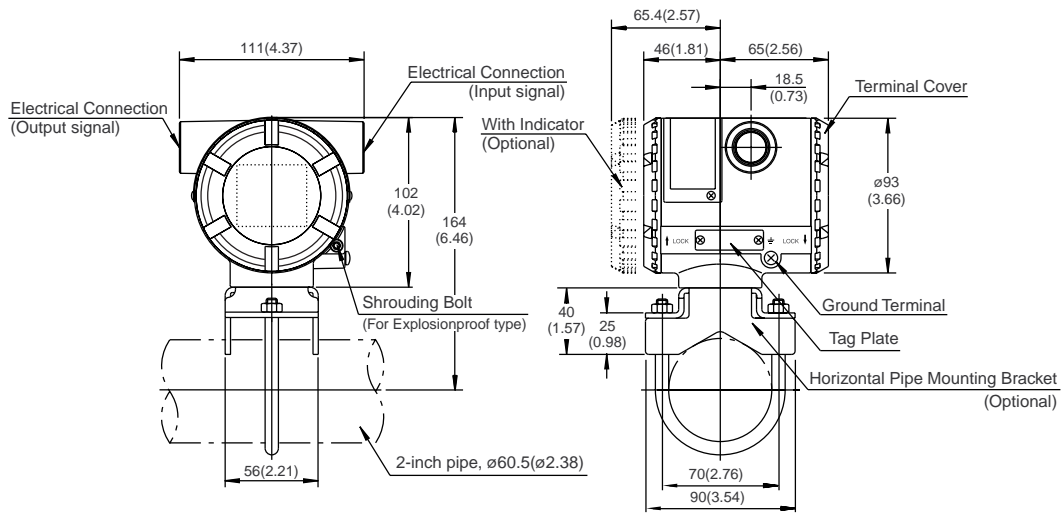

### ● 2-inch vertical pipe mounting

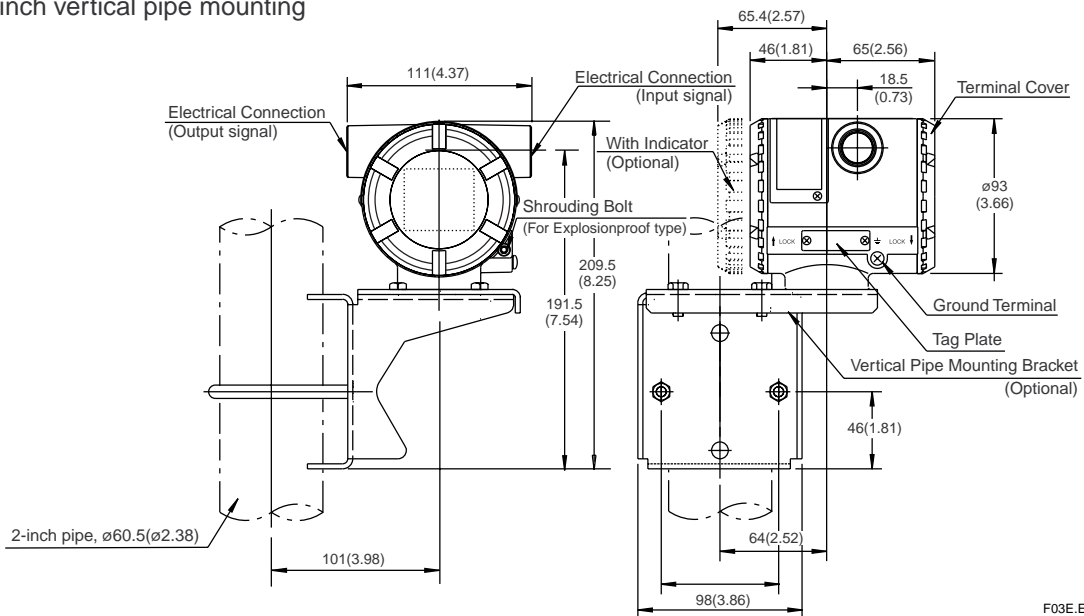

F03E.EPS

**Terminals**

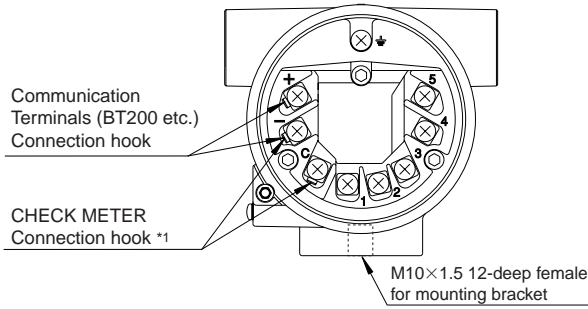

**Terminal Configuration**

+	Power Supply and output terminal
-	External Indicator (ammeter) terminal *1
C	External Indicator (ammeter) terminal *1
⏏	Ground terminal

\*1: When using an external indicator or check meter, the internal resistance must be 10Ω or less. This hook is not available for Fieldbus communication type(output signal code F).

F04.EPS

**Input Wiring**

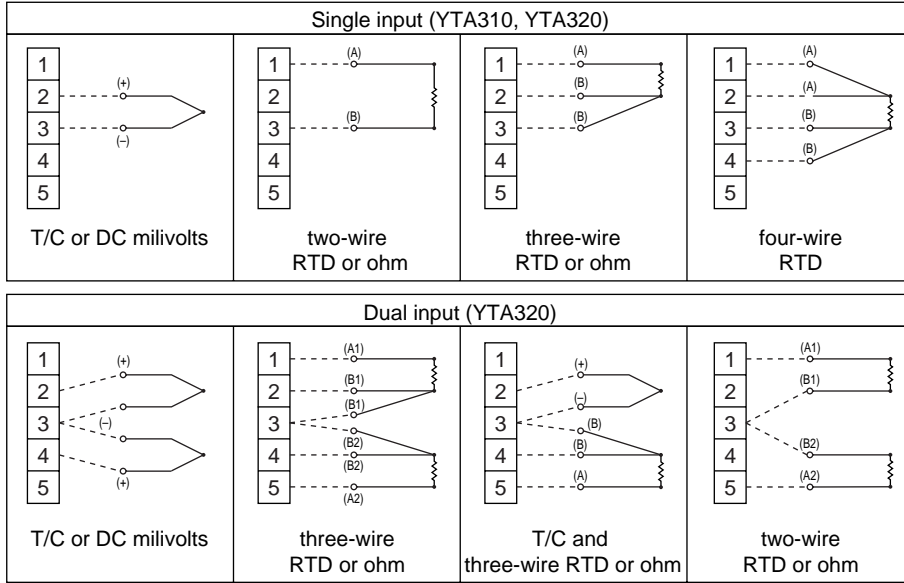

F05.EPS

**< Ordering Information > “◇”**

Specify the following when ordering. For output signal code F, refer to GS 01C50T02-00E.

Model, suffix codes, and optional codes

The instrument is shipped with the settings shown in Table A. Specify the followings when necessary.

1. Sensor type.  
For RTD and resistance input, specify the number of wire as well. For YTA320, specify the type for two inputs.\*1  
(Example; Pt200 3-wire system)
2. Calibration range and unit
  - 1) Calibration range can be specified within the measurement range shown in Table 1. on page 3.
  - 2) Specify one range from °C, K, °F or °R for temperature input. °F and °R are available when Optional code D2 is specified. It is not necessary to specify the unit of mV and ohm input, for these units automatically will be mV or Ω.
3. Tag Number
4. Other Items related with options  
/CA option allows specifying the setting Descriptor for HART protocol type at factory.  
Specify upto 16 characters to be entered in the Descriptor parameter.

\*1 For YTA320 when 4-wire RTD is specified as Sensor1, Sensor2 cannot be used.

**Table A. Settings upon shipment.**

Input sensor type	Pt100 three-wire system, or as specified
Calibration range lower limit	"0" or as specified
Calibration range upper limit	"100" or as specified
Calibration unit	"°C" or as specified
Damping time constant	2 seconds
Sensor burnout *1	High (110%, 21.6 mA DC)
Output in Transmitter failure *1	High (110%, 21.6 mA DC or more)
Integral Indicator *2	PV
Output type	Sensor 1
Tag number	As specified in order

\*1: Except when Optional code C1 or C2 is specified.

T07E.EPS

\*2: When Integral indicator is specified.

**< Related Instruments >**

Power Distributor: Refer to GS 01B04T01-02E or GS 01B04T02-00E  
BRAIN TERMINAL: Refer to GS 01C00A11-00E

**< Reference >**

HART; Trademark of The HART Communication Foundation. (USA)  
FOUNDATION Fieldbus ; Trademark of The Fieldbus Foundation. (USA)

**Material Cross Reference Table**

SUS304	AISI 304
--------	----------

T08E.EPS