

General Specifications

Model YTA50
Temperature Transmitter

YTA SERIES

GS 01C50C01-00E

The YTA50 is a head mount type of temperature transmitter that accepts thermocouple, RTD, ohms or DC millivolts input and converts it to a 4 to 20 mA DC signal for transmission. The YTA50 conforms to the standard DIN form B head mounting.



■ STANDARD SPECIFICATIONS

Accuracy

See Table 1. on page 2.

Cold Junction Compensation Accuracy

$\pm 1^{\circ}\text{C}$ ($\pm 1.8^{\circ}\text{F}$) (For T/C only)

Ambient Temperature Effects

See Table 1. on page 2.

Power Supply Effects

$\pm 0.005\%$ of FS per Volt

RFI Effects

Tested per EN 50 082-2, field intensity up to 10 V/m.

EMC Conformity CE

EN61326

Input Type, Span and Range

Selection from thermocouples (T/C), 2-, 3-, and 4-wire RTDs. See Table 1 on page 2.

Maximum Zero offset

$\pm 50\%$ of the maximum temperature

Input Signal Source Resistance

10 M Ω , or 3 k Ω at power-off

Input Lead Wire Resistance

5 Ω per wire or lower

Burnout

High or Low

Output

Two wire 4 to 20 mA DC

Response Time

1 to 60 seconds (programmable)

Ambient Temperature Limits

(Option code may affect limit)
-40 to 85 $^{\circ}\text{C}$ (-40 to 185 $^{\circ}\text{F}$)

Ambient humidity limits

5 to 90% RH at 40 $^{\circ}\text{C}$ (104 $^{\circ}\text{F}$)

Supply Voltage

7 to 35 V DC
7 to 28 V DC for Intrinsically safe type

Load Resistance

Limitation: 0 to $\{43 \times (E-7)\}$ [Ω]
where E is power supply voltage.
Typical; 731 Ω @ 24 V DC

Isolation

Input/output isolated to 1500 V AC.

Enclosure:

Material

Polycarbonate

Color of the case

Red

Mounting

DIN form B head mounting

Terminals

M3 screws

Weight

50 g (0.11 lb)

Table 1. Input type, range and accuracy

Sensor type	Standard	Input ranges		Minimum span		Accuracy (value whichever is greater)	Temp. effects/10°C (value whichever is greater)
		°C	°F	°C	°F		
<T/C>							
B	IEC584	400 to 1820	752 to 3308	200	360	± 0.1% of span or ±2.0°C	± 0.1% of span or ±2.0°C
E		-100 to 1000	-148 to 1832	50	90		
J		-100 to 1200	-148 to 2192	50	90	± 0.1% of span or ±1.0°C	± 0.1% of span or ±0.5°C
K		-180 to 1372	-292 to 2502	50	90		
N		-180 to 1300	-292 to 2372	100	180		
R		-50 to 1760	-58 to 3200	200	360	± 0.1% of span or ± 2.0°C	± 0.1% of span or ±2.0°C
S		-50 to 1760	-58 to 3200	200	360		
T	-200 to 400	-328 to 752	50	90	± 0.1% of span or ± 1.0°C	± 0.1% of span or ±0.5°C	
L	DIN43710	-100 to 900	-148 to 1652	50			90
U		-200 to 600	-328 to 1112	75	135		
W3	ASTM	0 to 2300	32 to 4172	200	360	± 0.1% of span or ± 2.0°C	± 0.1% of span or ±2.0°C
W5	E988-90	0 to 2300	32 to 4172	200	360		
<RTD>							
Pt100	IEC751	-200 to 850	-328 to 1562	10	18	± 0.1% of span or ± 0.2°C	± 0.1% of span or ± 0.1°C
Ni100	DIN43760	-60 to 250	-76 to 482	10	18		
DC Voltage [mV]		-10 to 800 [mV]		5 [mV]		± 0.1% of span or ± 0.01mV	± 0.1% of span or ± 10µV
Resistance [Ω]		0 to 5000 [Ω]		30 [Ω]		± 0.1% of span or ± 0.1Ω	± 0.1% of span or ± 0.1Ω

T01E.EPS

■ MODEL AND SUFFIX CODES

Model	Suffix code	Descriptions
YTA50	Temperature Transmitter (Head Mount Type)
Output Signal	- A	4 to 20mA DC
Optional Specifications	/ KS2	CENELEC ATEX (KEMA) Intrinsically safe approval Applicable standard: EN 50014, EN 50020, EN 50284 Certificate: KEMA 06 ATEX0191X II 1GD EEx ia IIC T4 or T6 Ambient Temperature: -40 to 85°C for T4, -40 to 60°C for T6 Supply/Input circuit: Ui=30V, Ii=120mA, Pi=0.84W, Ci=1nF, Li=10µH Sensor circuit: Uo=9.6V, Io=25mA, Po=60mW, Co=2.4µF, Lo=33mH
	/ DS2	FM intrinsically safe and CENELEC ATEX intrinsically safe approval combination (For CENELEC ATEX Intrinsically safe approval, see /KS2) [FM Intrinsically safe approval] Applicable standard: FM 3600, FM 3610, FM 3611, FM 3810 Class I Division 1 Groups A, B, C and D Ambient Temperature : -40 to 60°C (-40 to 140°F) Supply : Vmax=28V, Imax=120mA, Pmax=0.84W, Ci≤1nF, Li≤10µH

T02E.EPS

DIMENSIONS

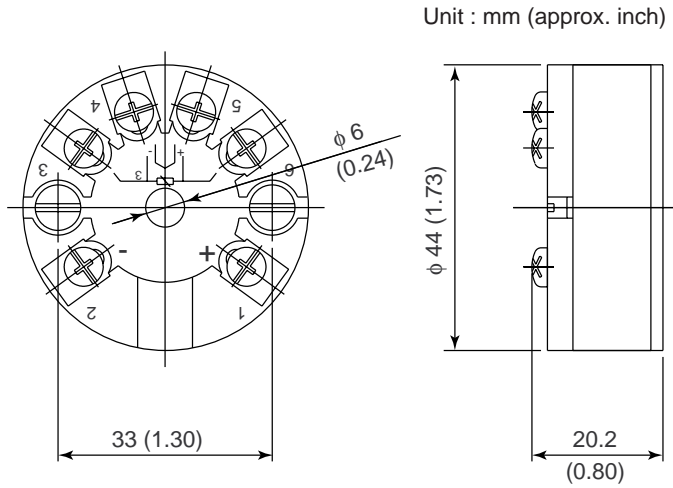

F01.EPS

● Sensor Connections

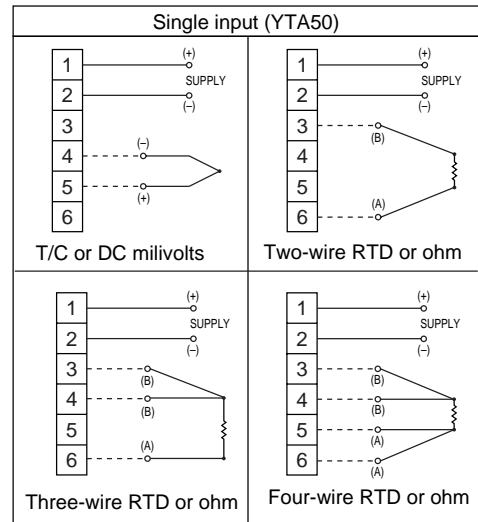

< Ordering Information >

Specify the following when ordering.

1. Model, suffix codes, and optional specification codes
2. Sensor type. For RTD input, specify the number of wire together. For example; Pt100, 4-wire
3. Calibration range. Specify upper and lower range value, so as to make the span wider than the minimum span limit.
4. Sensor burnout. Specify high or low.
5. Response time. Specify an integral number from 1 through 60. ("1" is recommended.)