

---

**User's  
Manual**

**ADMAG**

**Models AM100D, AM200D,  
AM300D, AM400D, and AM500D  
Magnetic Flow Tube**

IM 1E6D0-01E

---

# CONTENTS

---

<b>1. INTRODUCTION .....</b>	<b>1-1</b>
<b>2. HANDLING PRECAUTIONS .....</b>	<b>2-1</b>
2.1 Checking Model and Specifications .....	2-1
2.2 Accessories .....	2-1
2.3 Storage Precautions .....	2-1
2.4 Installation Location Precautions .....	2-1
2.5 Terminal Box Reorientation Precautions .....	2-1
<b>3. INSTALLATION .....</b>	<b>3-1</b>
3.1 Piping Design Precautions .....	3-1
3.2 Handling Precautions .....	3-3
3.2.1 General Precautions .....	3-3
3.2.2 Flow Tube Piping .....	3-4
3.3 Mounting .....	3-5
3.3.1 Nominal Diameter 2.5 mm (0.1") to 10 mm (0.4") Union Joint Type .....	3-5
3.3.2 Nominal Diameter 2.5mm (0.1") to 40mm (1.5") Wafer Type .....	3-6
3.3.3 Nominal Diameter 50 mm(2") to 200 mm(8") Wafer Type .....	3-9
3.3.4 Nominal Diameter 15 mm (0.5") to 400 mm (16") Flange Type .....	3-12
3.3.5 Nominal Diameter 500 mm (20") to 2600 (104") Flange Type .....	3-14
3.3.6 Mounting Procedure for Sanitary Type .....	3-15
3.4 Wiring Precautions .....	3-16
3.4.1 Protective Grounding .....	3-16
3.4.2 General Precautions .....	3-16
3.4.3 Cable Types .....	3-16
3.4.4 Connection to AM11Magnetic Flow Converter .....	3-17
3.4.5 Wiring Ports .....	3-18
<b>4. MAINTENANCE .....</b>	<b>4-1</b>
4.1 Regular Inspection Items .....	4-1
4.2 Trouble Shooting .....	4-1
<b>5. OUTLINE .....</b>	<b>5-1</b>
<b>6. HAZARDOUS DUTY TYPE INSTRUMENT .....</b>	<b>6-1</b>
6.1 FM .....	6-1
6.2 CSA .....	6-2
6.3 CENELEC (KEMA) .....	6-2
6.4 JIS .....	6-3
<b>INSTALLATION AND OPERATING PRECAUTIONS FOR JIS FLAMEPROOF EQUIPMENT .....</b>	<b>EX-B03E</b>

# 1. INTRODUCTION

---

This instrument has been already adjusted at the factory before shipment.

To ensure correct use of the instrument, please read this manual thoroughly and fully understand how to operate the instrument before operating it.

## ■ Regarding This Manual

- This manual should be passed on to the end user.
- Before use, read this manual thoroughly to comprehend its contents.
- The contents of this manual may be changed without prior notice.
- All rights reserved. No part of this manual may be reproduced in any form without Yokogawa's written permission.
- Yokogawa makes no warranty of any kind with regard to this material, including, but not limited to, implied warranties of merchantability and suitability for a particular purpose.
- All reasonable effort has been made to ensure the accuracy of the contents of this manual. However, if any errors are found, please inform Yokogawa.
- Yokogawa assumes no responsibilities for this product except as stated in the warranty.
- If the customer or any third party is harmed by the use of this product, Yokogawa assumes no responsibility for any such harm owing to any defects in the product which were not predictable, or for any indirect damages.

## ■ Safety Precautions

- The following general safety precautions must be observed during all phases of operation, service, and repair of this instrument. Failure to comply with these precautions or with specific WARNINGS given elsewhere in this manual violates safety standards of design, manufacture, and intended use of the instrument. YOKOGAWA Electric Corporation assumes no liability for the customer's failure to comply with these requirements. If this instrument is used in a manner not specified in this manual, the protection provided by this instrument may be impaired.

The following safety symbol marks are used in this manual and instrument;



### WARNING

---

A WARNING sign denotes a hazard. It calls attention to procedure, practice, condition or the like, which, if not correctly performed or adhered to, could result in injury or death of personnel.

---



### CAUTION

---

A CAUTION sign denotes a hazard. It calls attention to procedure, practice, condition or the like, which, if not correctly performed or adhered to, could result in damage to or destruction of part or all of the product.

---



### IMPORTANT

---

A IMPORTANT sign denotes an attention to avoid leading to damage to instrument or system failure.

---



### NOTE

---

A NOTE sign denotes a information for essential understanding of the operation and features.

---

- ⊕ Protective grounding terminal.
- ⊥ Function grounding terminal. This terminal should not be used as a "Protective grounding terminal".
- ~ Alternating current.
- Direct current.

## ■ Warranty

- The guaranteed term of this instrument is described in the quotation. We repair the damages that occurred during the guaranteed term for free.
- Please contact with our sales office when this instrument is damaged.
- If the instrument has trouble, please inform us model code, serial number, and concrete substances or situations. It is preferable to be attached a outline or data.
- We decide after the examination if free repair is available or not.
- Please consent to the followings for causes of damages that are not available as free repair, even if it occurred during the guaranteed term.

A: Unsuitable or insufficient maintenance by the customer.

B: The handling, using, or storage that ignore the design and specifications of the instrument.

C: Unsuitable location that ignore the description in this manual.

D: Remaking or repair by a person except whom we entrust.

E: Unsuitable removing after delivered.

F: A natural disaster (ex. a fire, earthquake, storm and flood, thunderbolt) and external causes.

### For the safety using;



### **WARNING**

---

- The Magnetic Flow Tube is a heavy instrument. Please give attention to prevent that persons are injured by carrying or installing. It is preferable for carrying the instrument to use a cart and be done by two or more persons.
  - In wiring, please confirm that the cables are not powered before connecting.
  - When removing the instrument from hazardous processes, avoid contact with the fluid and the interior of the meter.
  - In case of Hazardous duty type instrument, further requirements and differences are described in Chapter 6 "HAZARDOUS DUTY TYPE INSTRUMENT". The description in Chapter 6 is prior to other description in this instruction manual.
-

## 2. HANDLING PRECAUTIONS

This instrument has been already tested thoroughly at the factory. When the instrument is delivered, please check externals and make sure that no damage occurred during transportation.

In this chapter, handling precautions are described. Please read this chapter thoroughly at first. And please refer to the relative matter about other ones.

If you have any problems or questions, please make contact with Yokogawa sales office.

### 2.1 Checking Model and Specifications

The model and specifications are shown on the Data Plate. Please confirm the specifications between the instrument that was delivered and the purchase order (refer to the chapter 5. Outline).

Please let us know Model and Serial No. when making contact with Yokogawa sales office.

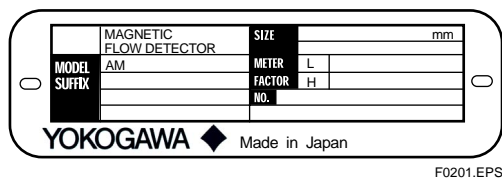

Figure 2.1 Data Plate

### 2.2 Accessories

When the instrument is delivered, please make sure that the following accessories are in the package.

- Centering device 1-set (for wafer type)
- Hexagonal wrench 1-piece (for hazardous duty type except JIS flameproof type)
- Hexagonal wrench 2-piece (only for JIS flameproof type)

### 2.3 Storage Precautions

In case the instrument is expected to be stored over a long term, please give attention to the followings;

- The instrument should be stored in its original packing condition.
- The storage location should be selected according to the following conditions:
  - 1) The location where it is not exposed to rain or water.
  - 2) The location where there is few vibration or shock.
  - 3) Temperature and humidity should be:
    - Temperature:  $-30$  to  $60^{\circ}\text{C}$  ( $-22$  to  $140^{\circ}\text{F}$ )
    - Humidity: 5 to 80% RH (no condensation)
 Preferable ambient temperature and humidity are  $25^{\circ}\text{C}$  ( $77^{\circ}\text{F}$ ) and about 65% RH.

### 2.4 Installation Location Precautions

Please select the installation location considering the following items to ensure long term stable operation of the flow tube.

- Ambient Temperature:
  - Please avoid to install the instrument at the location where temperature changes continuously. If the location receives radiant heat from the plant, provide heat insulation or improve ventilation.
- Atmospheric Condition:
  - Please avoid to install the instrument in an corrosive atmosphere. In case of installing in the corrosive atmosphere, please keep ventilating sufficiently and prevent rain from entering the conduit.
- Vibration or shock:
  - Please avoid to install the instrument at the location where there is heavy vibration or shock.

### 2.5 Terminal Box Reorientation Precautions

Please do not change the terminal box orientation at the customer's site. If the terminal box reorientation is required, please contact Yokogawa office or service center.

# 3. INSTALLATION



## CAUTION

This instrument must be installed by expert engineer or skilled personnel. The procedures described in this chapter are not permitted for operators.

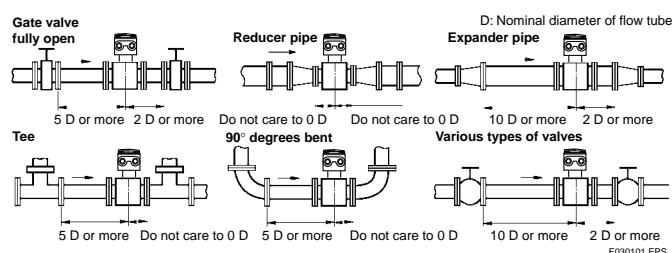

Figure 3.1.1 Minimum Length of Required Straight Run



## NOTE

- Nothing must be inserted or installed in the metering pipe than may interfere with the magnetic field, induced signal voltages, and flow velocity distribution.
- These straight runs may not be required on the downstream side flowmeter. However, if the downstream valve or other fittings cause channeling on the upstream side, provide a straight run of 2 D to 3 D on the downstream side.

## 3.1 Piping Design Precautions



### IMPORTANT

Please design the correct piping referring to the followings to prevent damage for flow tube and to keep correct measuring.

#### (1) Location



### IMPORTANT

Please install the flow tube to the location where it is not exposed to direct sunlight and ambient temperature is  $-10$  to  $+60^{\circ}\text{C}$  ( $14$  to  $140^{\circ}\text{F}$ ).

#### (2) Noise Rejection



### IMPORTANT

The instrument should be installed away from large electrical motors, transformers and other power sources in order to avoid interference with the measurement.

#### (3) Length of Straight Run

To keep accurate measuring, JIS B7554 “Electro Magnetic Flow Tubes” explains about upstream piping condition of Magnetic Flow Tubes.

We recommend to our customers about the piping conditions shown in Figure 3.1.1 based on JIS B7554 and our piping condition test data.

#### (4) Liquid Conductivity



### IMPORTANT

Please avoid to install the flow tube at location where liquid conductivity is likely to be non-uniform. Because it is possible to have bad influences to the flow indication by non-uniform conductivity when a chemical liquid is injected from upstream side close to the flow tube. When this occurs, it is recommended that chemical application ports are installed on the downstream side of the flow tube. In case chemicals must be added upstream side, please keep the pipe length enough so that liquid is properly mixed.

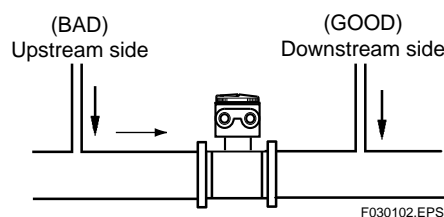

Figure 3.1.2 Chemical Insertion

**(5) Liquid Sealing Compound**

**IMPORTANT**

Please give attention in using Liquid Sealing Compound to the piping, because it brings bad influences to measurement by flowing out and cover the surfaces of electrode and earth-ring.

**(6) Service Area**

Please select the location where there is enough area to service installing, wiring, overhaul, etc.

**(7) Bypass Line**

It is recommended to install the Bypass Line to facilitate maintenance and zero adjustment.

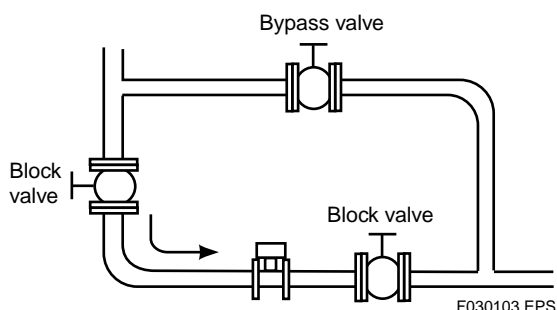

Figure 3.1.3 Bypass Line

**(8) Supporting the Flow Tube**

**CAUTION**

Please avoid to support only the flow tube, but fix pipes at first and support the flow tube by pipes to protect the flow tube from forces caused by vibration, shock, expansion and contraction through piping.

For small sized flow tubes, please provide a mounting base so that the tubes are fixed in the piping. See the section 3.3 Mounting.

**(9) Piping Condition**

**IMPORTANT**

The piping should be designed so that a full pipe is maintained at all times to prevent loss of signal and erroneous readings.

Please design the piping that a fluid is always filled in the pipes. The Vertical Mounting is effective for fluids that is easily separate or slurry settles within pipes.

In this case, please flow a fluid from bottom to up.

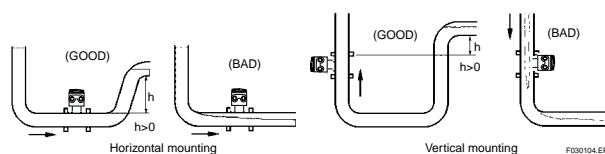

Figure 3.1.4 Filling the Pipe with Liquid

**(10) No Air Bubbles**

**IMPORTANT**

Please give attention to prevent bad influences or measuring errors from air bubbles that gathers inside measuring pipes.

In case the fluid includes air bubbles, please design the piping that prevent to gather air bubbles. In case valves are installed upstream of the flow tube, it is possible that a valve causes air bubbles, please install the flow tube upstream side of a valve.

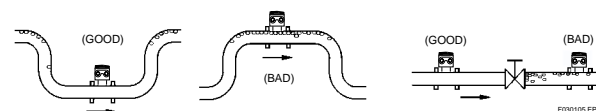

Figure 3.1.5 Avoiding Air Bubbles

**(11) Mounting Direction**

**IMPORTANT**

When the electrodes are vertical to ground, the electrode is covered with air bubbles at upper side or slurry at downside, and it may cause the measuring errors.

Please be sure to mount the terminal box upper side of piping to prevent water penetration into terminal box.

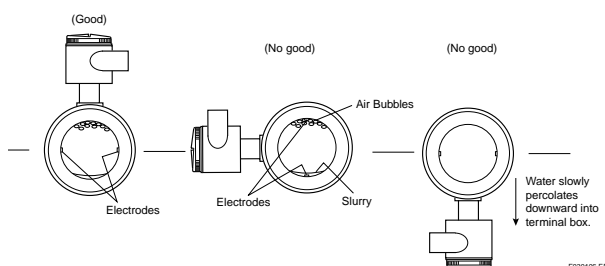

Figure 3.1.6 Mounting Direction

(12) Grounding

**IMPORTANT**

Improper grounding can have an adverse affect on the flow measurement. Please ensure that the instrument is properly grounded.

The electromotive force of the magnetic flow tube is minute and it is easy to be affected by noise. And also that reference electric potential is the same as the measuring fluid potential. Therefore, the reference electric potential (terminal potential) of the Flow Tube and the Converter/Amplifier also need to be the same as the measuring fluid. And moreover, that the potential must be the same with ground.

Please be sure to ground according to Figure 3.1.7.

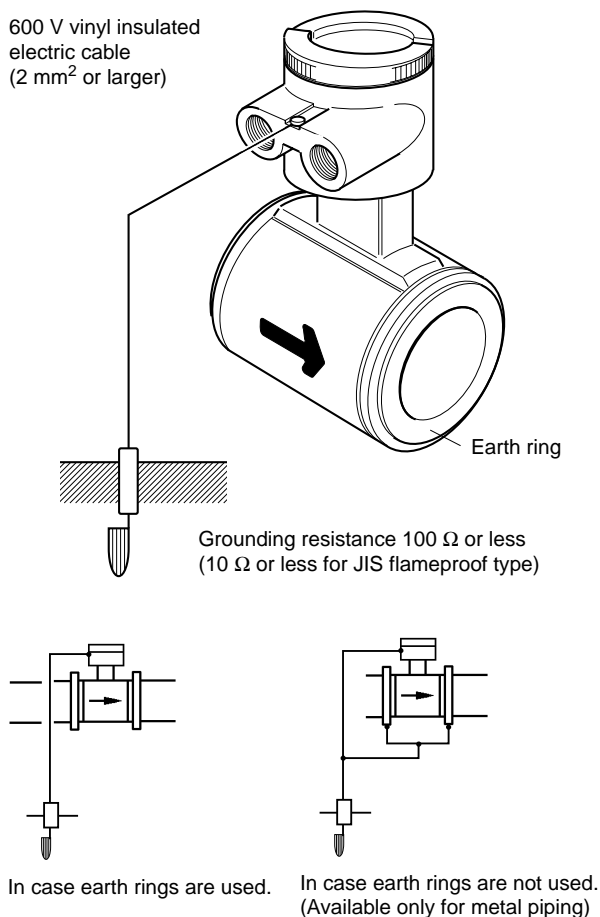

Figure 3.1.7 Grounding

F030107.EPS

## 3.2 Handling Precautions

**WARNING**

The Magnetic Flow tube is a heavy instrument. Please be careful to prevent persons from injuring when it is handled.

### 3.2.1 General Precautions

(1) Precaution for Carrying

The Magnetic Flow Tube is packed tightly. When it is unpacked, please give attention to prevent damages to the flow tube. And to prevent the accident during carry to the installing location, please carry it near the location keeping packed as it delivered.

**CAUTION**

In case the Magnetic Flow Tube lifts up, please refer to Figure 3.2.1. Please never lift up by using a bar through the flow tube. It damages liner severely.

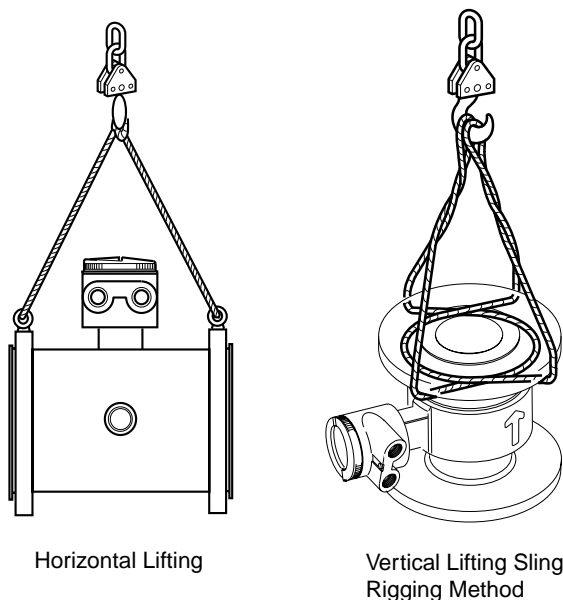

Figure 3.2.1 Lifting Flow Tubes

F030201.EPS

**(2) Precaution for Shock****CAUTION**

Care should be taken not to drop the flow tube or subject it to excessive shock. This may lead to liner damage which will cause inaccurate readings.

**(3) Flange Protection Covers****IMPORTANT**

Please keep the protection cover (ex. corrugated paper or anything possible to protect) attached with flange except when mounting to the pipe.

**(4) Terminal Box Cover****IMPORTANT**

Please never leave the terminal box cover open until wiring to prevent insulation deterioration.

**(5) Long-term Non-use****IMPORTANT**

It is not preferable to leave the flow tube for long term non-use after installation.

In case the flow tube is compelled to do that, please take care of the flow tube by the followings.

- Confirmation of Sealing Condition for the Flow Tube  
Please confirm the sealing conditions of the terminal box screw and wiring ports.  
In case of the Conduit Piping, please provide the drain plugs or waterproof glands to it to prevent that moisture or water penetrates into the flow tube through the conduit.
- Regular Inspections  
Please inspect the sealing condition (as above mentioned) and inside of the terminal box. And when it is suspect that water penetration into the inside flow tube (ex. rain fall), please inspect when it happened.

**3.2.2 Flow Tube Piping****CAUTION**

Mis-aligned or slanted piping can lead to leakage and damage to flanges.

- Please correct mis-alignment or slanted piping and improper distance between mounting flanges before install the flow tube. (Please refer to Figure 3.2.2)
- Inside a pipeline which is newly installed, some foreign substances (such as welding scrap or wood chips) may exist. Please remove them by flushing piping before mounting the flow tube.

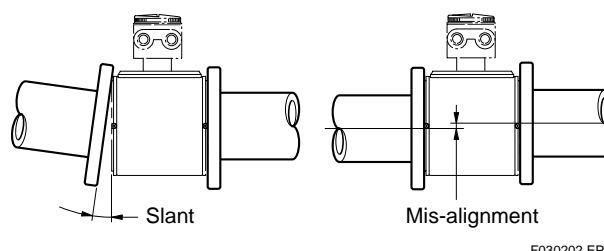

F030202.EPS

**Figure 3.2.2 Slant and Mis-alignment of Flow Tube Piping**

### 3.3 Mounting

#### 3.3.1 Nominal Diameter 2.5 mm (0.1") to 10 mm (0.4") Union Joint Type

**NOTE**

Please ensure to use the attached connecting fittings.

Ceramic linings with a diameter of 2.5, 5 or 10 mm are connected using union joints.

Use the connecting fittings according to the table below. Depending on whether the fitting is to be welded to or screwed on to the piping.

**Table 3.3.1 Fitting Dimensions**

**Screw joint (Code: U2, U3)**

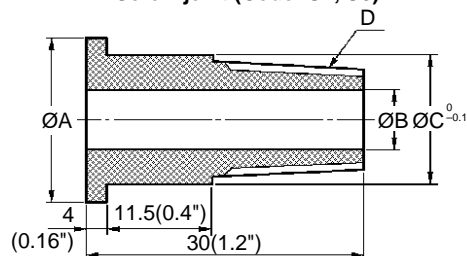

Size mm(inch)	Code	A	B	C	D
2.5(0.1)	U2	22(0.87")	8(0.31")	18.5(0.73")	R1/4(PT1/4)
	U3	22(0.87")	8(0.31")	18.5(0.73")	NPT1/4
5(0.2)	U2	22(0.87")	8(0.31")	18.5(0.73")	R1/4(PT1/4)
	U3	22(0.87")	8(0.31")	18.5(0.73")	NPT1/4
10(0.4)	U2	25(0.98")	10(0.39")	22.5(0.89")	R3/8(PT3/8)
	U3	25(0.98")	10(0.39")	22.5(0.89")	NPT3/8

**Weld joint (Code: U1)**

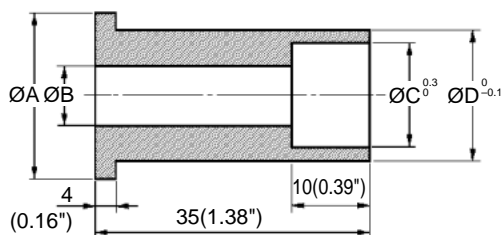

Size mm(inch)	Code	A	B	C	D
2.5(0.1)	U1	22(0.87")	8(0.31")	14.3(0.56")	18.5(0.73")
5(0.2)	U1	22(0.87")	8(0.31")	14.3(0.56")	18.5(0.73")
10(0.4)	U1	25(0.98")	10(0.39")	17.8(0.70")	22.5(0.89")

T030301.EPS

#### (1) Mounting Direction

Please mount the Magnetic Flow Tube matching the flow direction of the fluid to be measured with the direction of the arrow mark on the flow tube.

**IMPORTANT**

If it is impossible to match the direction, please never remodel by changing direction of the terminal box. In case the measuring fluid flows against the arrow direction, please refer to the section "Reversing Flow Direction" in the Instruction Manual of AM11 Magnetic Flow Converter.

#### (2) Connecting Process Piping

Weld or screw the connecting fittings to the process piping.

**IMPORTANT**

- Please be sure to pass the connecting fittings through the union joint nuts in advance. Then connect the connecting fitting to the piping by screwing or welding the connecting fitting to the piping (see Figure 3.3.1).
- In case of weld joint type, please pay attention the welding condition to avoid deforming piping or making the stagnant portion of the fluid; joint preparation, level difference in butt joint, welding current.

#### (3) Positioning the Flow Tube

Install the magnetic flow tube on a mounting base and position it so that the center axis of the flow tube is aligned with that of the piping. Then mount the flow tube to union joint nuts by screwing the nuts to the connecting ports of the flow tube.

**CAUTION**

The ceramic pipe will be damaged if they are tightened when they are not properly aligned.

**(4) Tightening Nuts****CAUTION**

Tighten the union joint nuts according to Torque Values in Table 3.3.1 using a torque wrench. As the gasket material is Fluorocarbon PTFE, it is possible that nuts may loose by it's character as time passes. Please tighten the nuts regularly. The table below shows the tightening torque values. Be sure to use gasket : t=1.5 attached.

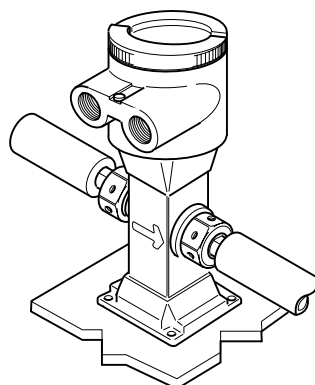
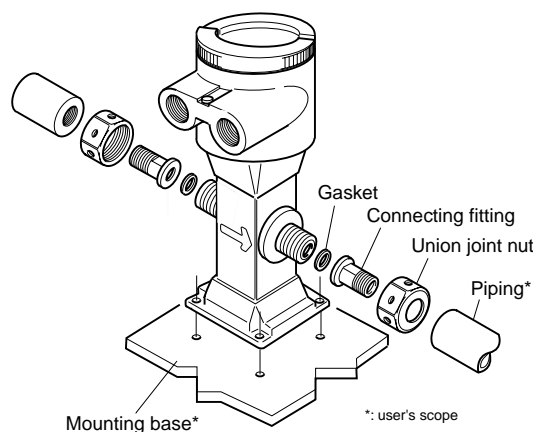

Horizontal Mounting

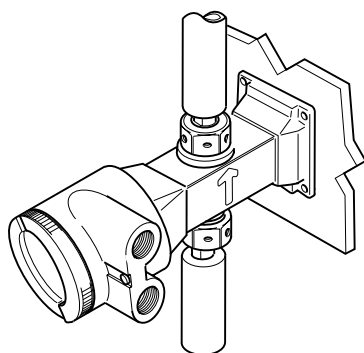

Vertical Munting

F030301.EPS

**Figure 3.3.1 Mounting Procedure (Size: 2.5 mm(0.1") to 10 mm(0.4"))**

Table 3.3.2

Size: mm(inch)	Tightening Torque N-m {kgf-cm} [in-lbf]
2.5(0.1)	Max.12{122}[106]
5(0.2)	Max.12{122}[106]
10(0.4)	Max.18{183}[160]

T030302.EPS

### 3.3.2 Nominal Diameter 2.5mm (0.1") to 40mm (1.5") Wafer Type

**IMPORTANT**

Please use appropriate bolts and nuts according to process connection. In case stud type of through bolts are used, be sure outside diameter of a shank is smaller than a thread ridge's one. Please use compressed non-asbestos fiber gasket, PTFE gasket or the gasket which has equal elasticity. In case of optional code/FRG, please use rubber gasket or others which has equal elasticity. Be sure the inner diameter of the gasket does not protrude to inner piping. (Refer to Table 3.3.8)

**(1) Mounting Direction**

Please mount the Magnetic Flow Tube matching the flow direction of the fluid to be measured with the direction of the arrow mark on the flow tube.

**IMPORTANT**

If it is impossible to match the direction, please never remodel by changing direction of the terminal box. In case the measuring fluid flows against the arrow direction, please refer to the section "Reversing Flow Direction" in the Instruction Manual of AM11 Magnetic Flow Converter.

**(2) Mounting Centering Devices**

To keep concentricity of the Flow Tube with pipes, please mount centering devices on the Mini-Flanges of the Flow Tube.

Please give attention to the nominal diameter and flange ratings of the centering devices.

**(3) Positioning Flow Tube**

Please pass two through-bolts to adjacent holes of both flanges and mount the Flow Tube, and pass other through-bolts to other holes. (Refer to Figure 3.3.2/ 3.3.3) In case stud type of through-bolts are used, position them coming in contact centering devices with thread of bolts.

**(4) Tightening Nuts**

Please tighten the bolts according to Torque Values in Table 3.3.3. In case of PVC piping, please select optional code /FRG, use rubber gasket and tighten with the torque value in Table 3.3.4.

**CAUTION**

In case of PFA lining type, as the lining material is Fluorocarbon PFA, it is possible that nuts may loose by its character as time passes. Please tighten the nuts regularly.

Please be sure to tighten the bolts following prescribed torque values. Please tighten the flange bolts diagonally with the same torque values, step by step up to the prescribed torque value.

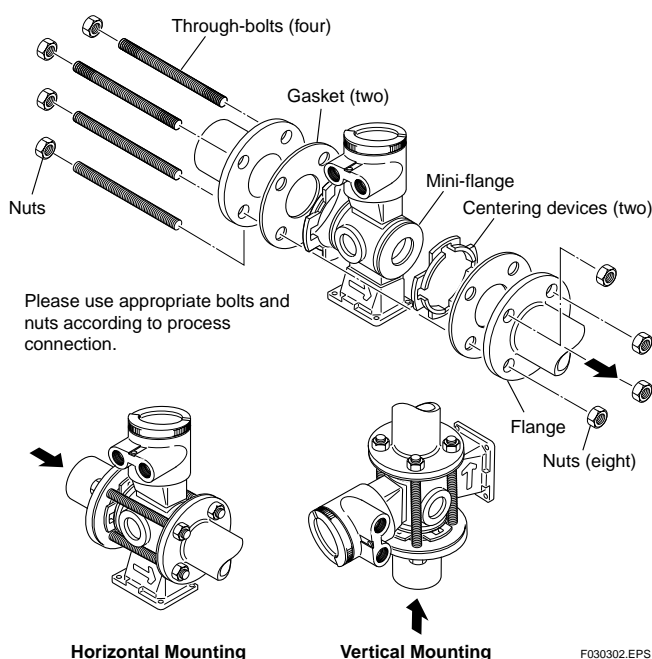

Figure 3.3.2 Mounting Procedure (Size: 2.5 mm(0.1") to 15 mm(0.5"))

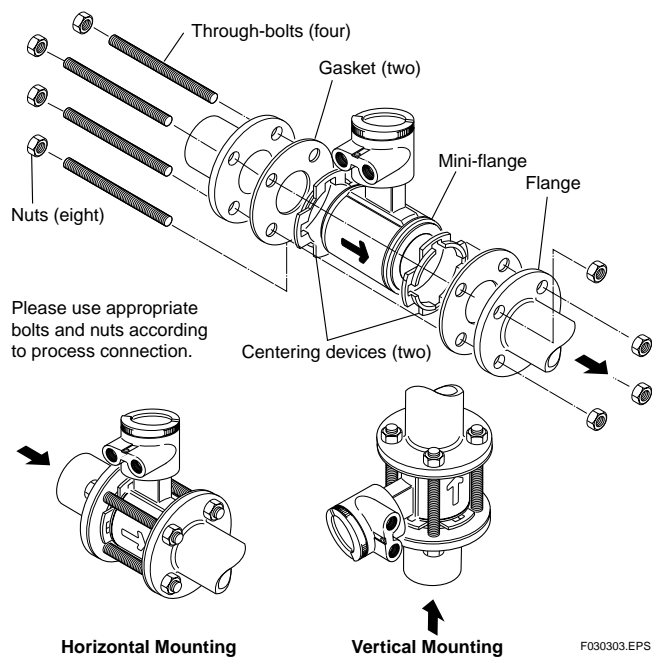

Figure 3.3.3 Mounting Procedure (Size: 25 mm(1"), 40 mm(1.5"))

Table 3.3.3 Tightening Torque Values for Metal Piping

Tightening Torque Values for PFA lining / Polyurethane lining Type N-m {kgf-cm} [in-lbf]						
Size mm(inch)	Flange Rating	JIS		ANSI		DIN
		10K	20K	150	300	PN10/16
2.5(0.1), 5(0.2) 10(0.4), 15(0.5)		6 to 9 {61 to 92} [53 to 80]	6 to 9 {61 to 92} [53 to 80]	6 to 9 {61 to 92} [53 to 80]	6 to 9 {61 to 92} [53 to 80]	6 to 9 {61 to 92} [53 to 80]
25(1)		15 to 22 {153 to 224} [133 to 195]	15 to 22 {153 to 224} [133 to 195]	12 to 18 {122 to 184} [106 to 159]	15 to 22 {153 to 224} [133 to 195]	11 to 17 {112 to 173} [97 to 150]
40(1.5)		21 to 32 {214 to 327} [186 to 283]	21 to 32 {214 to 327} [186 to 283]	17 to 26 {173 to 265} [150 to 230]	25 to 38 {255 to 388} [221 to 336]	21 to 32 {214 to 327} [186 to 283]
Maximum Tightening Torque Values for Ceramic lining Type N-m {kgf-cm} [in-lbf]						
Size mm(inch)	Flange Rating	JIS		ANSI		DIN
		10K	20K	150	300	PN10/16
15(0.5)		14 {143} [124]	14 {143} [124]	14 {143} [124]	14 {143} [124]	14 {143} [124]
25(1)		30 {306} [265]	30 {306} [265]	22 {224} [195]	30 {306} [265]	25 {255} [221]
40(1.5)		44 {449} [389]	44 {449} [389]	33 {337} [292]	51 {520} [451]	50 {510} [442]

\*Please use compressed non-asbestos fiber gasket, PTFE gasket or the gasket which has equal elasticity.

T030303.EPS

Table 3.3.4 Tightening Torque Values for PVC Piping

Tightening Torque Values for PFA lining / Polyurethane lining Type N-m {kgf-cm} [in-lbf]						
Size mm(inch)	Flange Rating	JIS		ANSI		DIN
		10K	20K	150	300	PN10/16
2.5(0.1), 5(0.2) 10(0.4), 15(0.5)		2.0 {20} [18]	—	2.1 {21} [19]	—	2.0 {20} [18]
25(1)		5.2 {53} [46]	—	4.2 {43} [37]	—	4.0 {41} [35]
40(1.5)		7.4 {76} [65]	—	6.0 {61} [53]	—	7.4 {76} [65]
Maximum Tightening Torque Values for Ceramic Type N-m {kgf-cm} [in-lbf]						
Size mm(inch)	Flange Rating	JIS		ANSI		DIN
		10K	20K	150	300	PN10/16
15(0.5)		1.3 {13} [12]	—	1.3 {13} [12]	—	1.3 {13} [12]
25(1)		3.5 {36} [31]	—	2.8 {29} [25]	—	2.7 {28} [24]
40(1.5)		5.7 {58} [50]	—	4.6 {47} [41]	—	5.7 {58} [50]

\*Please select optional code/FRG and use rubber gasket or others which has equal elasticity.

T030304.EPS

### 3.3.3 Nominal Diameter 50 mm(2") to 200 mm(8") Wafer Type

#### IMPORTANT

Please use appropriate bolts and nuts according to process connection. In case stud type of through bolts are used, be sure outside diameter of a shank is smaller than a thread ridge's one. Please use compressed non-asbestos fiber gasket, PTFE gasket or the gasket which has equal elasticity. In case of optional code/FRG, please use rubber gasket or others which has equal elasticity. Be sure the inner diameter of the gasket does not protrude to inner piping. (Refer to Table 3.3.8)

#### (1) Mounting Direction

Please mount the Magnetic Flow Tube matching the flow direction of the fluid to be measured with the direction of the arrow mark on the flow tube.

#### IMPORTANT

If it is impossible to match the direction, please never remodel to change direction of the terminal box. In case the measuring fluid flows against the arrow direction, please refer to the section "Reversing Flow Direction" in the Instruction Manual of AM11 Magnetic Flow Converter.

#### (2) Mounting Centering Devices

To keep concentricity between the Flow Tube and pipes, centering devices must be used. Pass two through-bolts through the four centering devices (two for each) and lower adjacent holes of both flanges. (Refer to Figure 3.3.4)

Please give attention to the nominal size and flange ratings of the centering devices. (Refer to Table 3.3.7)

#### (3) Positioning Flow Tube

Position the Flow Tube coming in contact four centering devices with Mini-Flanges. At this time, pay attention to avoid four centering devices come in contact with Housing. In case stud type of through-bolts are used, position them coming in contact four centering devices with thread of the bolts. (Refer to Figure 3.3.4) After positioning the Flow Tube, pass remaining through-bolts to remaining holes.

#### NOTE

When installing a size 150mm with JIS F12 (JIS75M) flange, please displace in circumferential direction slightly because the cover of electrode chamber will interfere against the bolts.

#### (4) Tightening Nuts

Please tighten the bolts according to Torque Values in Table 3.3.5. In case of PVC piping, please select optional code/FRG, use rubber gasket and tighten with the torque value in Table 3.3.6.

#### CAUTION

In case of PFA lining type as the lining material is Fluorocarbon PFA, it is possible that nuts loose by its character as time passes. Please tighten the nuts regularly.

Please be sure to tighten the bolts following prescribed torque values. Please tighten the flange bolts diagonally with the same torque values, step by step up to the prescribed torque value.

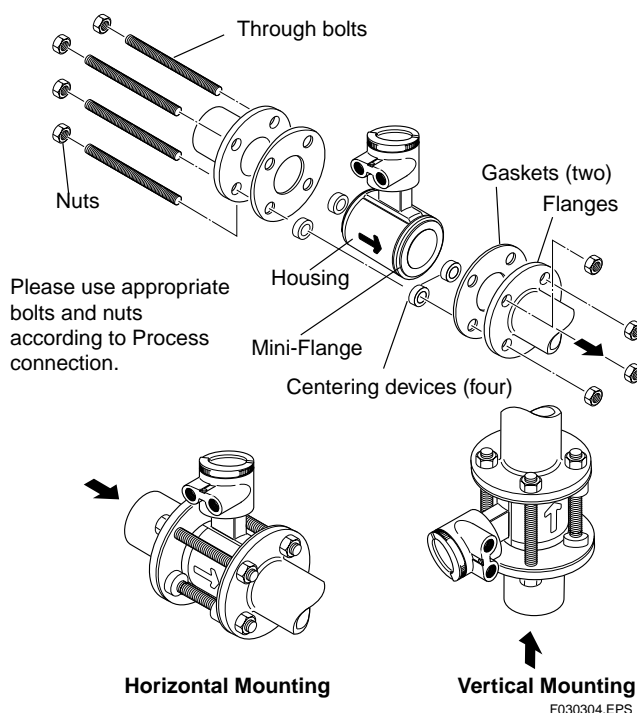

Figure 3.3.4 Mounting Procedure

Table 3.3.5 Tightening Torque Values for Metal Piping

Tightening Torque Values for PFA lining / Polyurethane lining Type N-m {kgf-cm} [in-lbf]								
Size mm(inch)	Flange Rating	JIS		ANSI		DIN		JIS G3451 F12
		10K	20K	150	300	PN10	PN16	
50(2)		28 to 42 {286 to 429} [248 to 372]	14 to 21 {143 to 214} [124 to 186]	28 to 42 {286 to 429} [248 to 372]	14 to 21 {143 to 214} [124 to 186]		28 to 42 {286 to 429} [248 to 372]	
80(3)		21 to 31 {214 to 316} [186 to 274]	26 to 39 {265 to 398} [230 to 345]	41 to 61 {418 to 622} [363 to 540]	25 to 37 {255 to 378} [221 to 327]		21 to 31 {214 to 316} [186 to 274]	41 to 62 {418 to 633} [363 to 549]
100(4)		35 to 51 {357 to 520} [310 to 451]	43 to 64 {439 to 653} [381 to 566]	35 to 51 {357 to 520} [310 to 451]	41 to 61 {418 to 622} [363 to 540]		35 to 52 {357 to 531} [310 to 460]	68 to 102 {694 to 1041} [602 to 903]
150(6)		65 to 94 {663 to 959} [575 to 832]	43 to 68 {439 to 694} [381 to 602]	63 to 89 {643 to 908} [558 to 788]	41 to 60 {418 to 612} [363 to 531]	65 to 94 {663 to 959} [575 to 832]	65 to 94 {663 to 959} [575 to 832]	68 to 100 {694 to 1020} [602 to 885]
200(8)		57 to 84 {582 to 857} [504 to 743]	61 to 92 {622 to 939} [540 to 814]	93 to 120 {949 to 1224} [823 to 1062]	65 to 93 {663 to 949} [575 to 823]	94 to 125 {959 to 1276} [832 to 1106]	58 to 84 {592 to 857} [513 to 743]	69 to 101 {704 to 1031} [611 to 894]
Maximum Tightening Torque Values for Ceramic lining Type N-m {kgf-cm} [in-lbf]								
Size mm(inch)	Flange Rating	JIS		ANSI		DIN PN		JIS G3451 F12
		10K	20K	150	300	PN10	PN16	
50(2)		50 {510} [442]	27 {276} [239]	50 {510} [442]	27 {276} [239]	—	63 {643} [558]	
80(3)		36 {367} [319]	44 {449} [389]	75 {765} [664]	44 {449} [389]	—	36 {367} [319]	80 {816} [708]
100(4)		48 {490} [425]	58 {592} [513]	49 {500} [434]	56 {571} [496]	—	48 {490} [425]	105 {1071} [929]
150(6)		79 {806} [699]	55 {561} [487]	66 {673} [584]	43 {439} [381]	—	76 {776} [673]	84 {857} [743]
200(8)		70 {714} [619]	76 {776} [673]	102 {1041} [903]	76 {776} [673]	103 {1051} [911]	67 {684} [593]	102 {1041} [903]

\*Please use compressed non-asbestos fiber gasket, PTFE gasket or the gasket which has equal elasticity.

T030305.EPS

Table 3.3.6 Tightening Torque Values for PVC Piping

Tightening Torque Values for PFA lining / Polyurethane lining Type N-m {kgf-cm} [in-lbf]								
Size mm(inch)	Flange Rating	JIS		ANSI		DIN		JIS G3451 F12(75M)
		10K	20K	150	300	PN10	PN16	
50(2)		9.8 {100} [87]	—	9.8 {100} [87]	—	—	9.8 {100} [87]	—
80(3)		7.2 {73} [64]	—	14.4 {147} [127]	—	—	7.2 {73} [64]	14.4 {147} [127]
100(4)		12.2 {124} [108]	—	12.2 {124} [108]	—	—	12.2 {124} [108]	24.4 {249} [216]
150(6)		21.4 {218} [189]	—	20.5 {209} [181]	—	21.4 {218} [189]	21.4 {218} [189]	23.4 {239} [207]
200(8)		19.3 {197} [171]	—	27.6 {282} [244]	—	28.9 {295} [256]	19.3 {197} [171]	31.6 {322} [280]
Maximum Tightening Torque Values for Ceramic lining Type N-m {kgf-cm} [in-lbf]								
Size mm(inch)	Flange Rating	JIS		ANSI		DIN		JIS G3451 F12(75M)
		10K	20K	150	300	PN10	PN16	
50(2)		8.2 {84} [73]	—	8.2 {84} [73]	—	—	8.2 {84} [73]	—
80(3)		6.2 {63} [55]	—	12.4 {127} [110]	—	—	6.2 {63} [55]	12.3 {126} [109]
100(4)		8.0 {82} [71]	—	8.1 {83} [72]	—	—	8.0 {82} [71]	16.1 {164} [142]
150(6)		19.8 {202} [175]	—	18.9 {193} [167]	—	19.8 {202} [175]	19.8 {202} [175]	21.6 {220} [191]
200(8)		17.5 {179} [155]	—	25.1 {256} [222]	—	26.2 {267} [232]	17.5 {179} [155]	28.7 {293} [254]

\*Please select optional code/FRG and use rubber or gasket or others which has equal elasticity.

T030306.EPS

Table 3.3.7 Centering Device Identification

Lining	Flange Rating	JIS 10K	JIS 20K	JIS G3451 F12	ANSI 150	ANSI 300	DIN PN 10/16
	mm(inch)						
PFA, polyurethane	50(2)	B	B	—	B	F	F
	80(3)	B	F	H	F	C	G
	100(4)	B	F	H	C	H	F
	150(6)	C	D	D	C	E	C
	200(8)	C	D	D	D	E	C
Ceramics	50(2)	B	B	—	B	F	F
	80(3)	B	F	H	F	C	G
	100(4)	B	F	H	C	H	F
	150(6)	B	C	G	B	D	B
	200(8)	B	C	C	G	J	B

\*Each Centering Devices is engraved a character as identification.

T030307.EPS

Table 3.3.8 Earth Ring inside diameter

Unit: mm(inch)			Unit: mm(inch)	
Size	PFA/Polyurethane lining	Ceramic lining	Size	Polyurethane lining
2.5(0.1)	φ15(0.6)	—	500(20)	φ468(18.4) [φ485(19.1)]
5(0.2)	φ15(0.6)	—	600(24)	φ563(22.2) [φ589(23.9)]
10(1.4)	φ15(0.6)	—	700(28)	φ665(26.2) [φ689(27.1)]
15(0.5)	φ15(0.6)	φ15(0.6)	800(32)	φ765(30.1) [φ788(31.0)]
25(1)	φ27(1.1)	φ27(1.1)	900(36)	φ855(33.7) [φ888(35.0)]
40(1.5)	φ40(1.6)	φ40(1.6)	1000(40)	φ942(37.1) [φ990(39.0)]
50(2)	φ52(2.1)	φ52(2.1)	1100(44)	φ1085(42.7)
80(3)	φ81(3.2)	φ81(3.2)	1200(48)	φ1185(46.7)
100(4)	φ98(3.9)	φ98(3.9)	1350(54)	φ1335(52.6)
150(6)	φ140.7(5.6)	φ144(5.7)	1500(60)	φ1485(58.5)
200(8)	φ188.9(7.5)	φ192(7.6)	1600(64)	φ1585(62.4)
250(10)	φ239.1(9.5)	—	1800(72)	φ1785(70.3)
300(12)	φ291.3(11.5)	—	2000(80)	φ1985(78.1)
350(14)	φ323.4(12.8)	—	2200(88)	φ2185(86)
400(16)	φ373.5(14.8)	—	2400(96)	φ2385(93.9)
			2600(104)	φ2585(101.8)

T030308.EPS

\* Please ensure that the I.D. of the gasket does not protrude into the I.D. of the Earth Ring.  
(This dimension is also applied when no earth ring is used)

\* [ ] ; for Process connection code G1

### 3.3.4 Nominal Diameter 15 mm (0.5") to 400 mm (16") Flange Type



#### IMPORTANT

Please use appropriate bolts and nuts according to process connection. Please use compressed non-asbestos fiber gasket, PTFE gasket or the gasket which has equal elasticity. In case of optional code/FRG, please use rubber gasket or others which has equal elasticity. Be sure the inner diameter of the gasket does not protrude to inner piping.(Refer to Table 3.3.8)

#### (1) Mounting Direction

Please mount the Magnetic Flow Tube matching the flow direction of the fluid to be measured with the direction of the arrow mark on the flow tube.



#### IMPORTANT

If it is impossible to match the direction, please never remodel to change direction of the terminal box. In case the measuring fluid flows against the arrow direction, please refer to the section "Reversing Flow Direction" in the Instruction Manual of AM11 Magnetic Flow Converter.

#### (2) Tightening Nuts

Please tighten the bolts according to Torque Values in Table 3.3.9. In case of PVC piping, please select optional code/FRG, use rubber gasket and tighten with the torque value in Table 3.3.10.



#### CAUTION

In case of PFA lining type as the lining material is Fluorocarbon PFA, it is possible that bolts loose by its character as time passes. Please tighten the nuts regularly.

Please be sure to tighten the bolts following prescribed torque values. Please tighten the flange bolts diagonally with the same torque values, step by step up to the prescribed torque value.

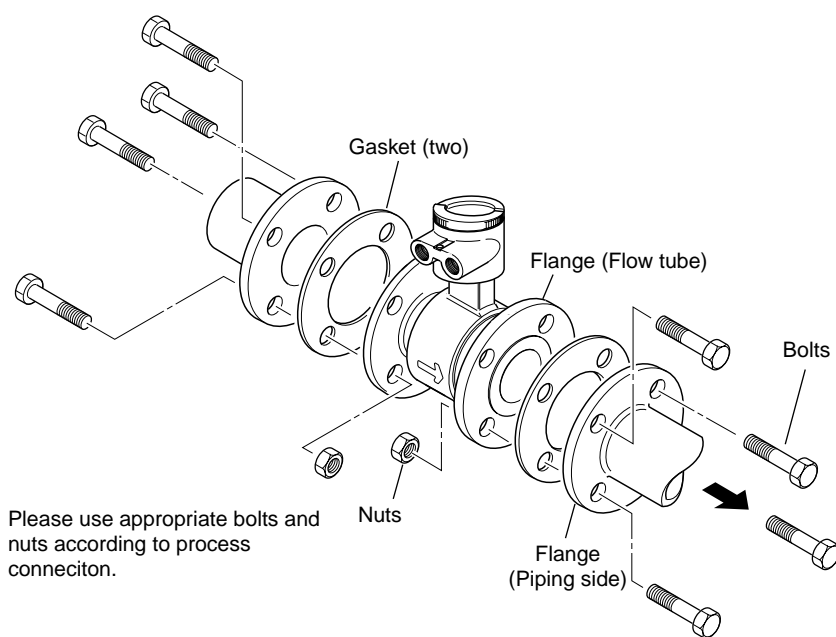

F030305.EPS

Figure 3.3.5 Mounting Procedure (Size: 15 mm (0.5") to 400 mm (16"))

Table 3.3.9 Tightening Torque Values for Metal Piping in N-m(kgf-cm) [in-lbf]

Size mm(inch)	Flange Rating	JIS		ANSI		DIN		JIS G3451 F12(75M)
		10K	20K	150	300	PN10	PN16	
15(0.5mm)		3 to 5 {31 to 51} [27 to 44]	3 to 5 {31 to 51} [27 to 44]	3 to 5 {31 to 51} [27 to 44]	3 to 5 {31 to 51} [27 to 44]	—	3 to 5 {31 to 51} [27 to 44]	—
25(1mm)		8 to 13 {82 to 133} [71 to 115]	8 to 13 {82 to 133} [71 to 115]	6 to 10 {61 to 102} [53 to 88]	8 to 13 {82 to 133} [71 to 115]	—	6 to 10 {61 to 102} [53 to 88]	—
40(1.5mm)		18 to 26 {184 to 265} [159 to 230]	18 to 26 {184 to 265} [159 to 230]	15 to 21 {153 to 214} [133 to 186]	21 to 31 {214 to 316} [186 to 274]	—	18 to 26 {184 to 265} [159 to 230]	—
50(2mm)		22 to 31 {224 to 316} [195 to 274]	11 to 16 {112 to 163} [97 to 142]	23 to 31 {235 to 316} [204 to 274]	11 to 16 {112 to 163} [97 to 142]	—	23 to 31 {235 to 316} [204 to 274]	—
80(3mm)		15 to 22 {153 to 224} [133 to 195]	18 to 27 {184 to 276} [159 to 239]	35 to 43 {357 to 439} [310 to 381]	18 to 26 {184 to 265} [159 to 230]	—	16 to 22 {163 to 224} [142 to 195]	33 to 47 {337 to 480} [292 to 416]
100(4mm)		21 to 35 {214 to 357} [186 to 310]	25 to 44 {255 to 449} [221 to 389]	22 to 35 {224 to 357} [195 to 310]	25 to 42 {255 to 429} [221 to 372]	—	21 to 35 {214 to 357} [186 to 310]	47 to 75 {480 to 765} [416 to 664]
150(6mm)		65 to 94 {663 to 959} [575 to 832]	43 to 68 {439 to 694} [381 to 602]	63 to 89 {643 to 908} [558 to 788]	41 to 59 {418 to 602} [363 to 522]	65 to 94 {663 to 959} [575 to 832]	65 to 94 {663 to 959} [575 to 832]	65 to 100 {663 to 1020} [575 to 885]
200(8mm)		57 to 84 {582 to 857} [504 to 743]	61 to 92 {622 to 939} [540 to 814]	93 to 120 {949 to 1224} [823 to 1062]	65 to 93 {663 to 949} [575 to 823]	94 to 125 {959 to 1276} [832 to 1106]	58 to 84 {592 to 857} [513 to 743]	69 to 101 {704 to 1031} [611 to 894]
250(10mm)		142 to 174 {1449 to 1776} [1257 to 1540]	154 to 182 {1571 to 1857} [1363 to 1611]	145 to 177 {1480 to 1806} [1283 to 1566]	126 to 151 {1286 to 1541} [1115 to 1336]	136 to 164 {1388 to 1673} [1204 to 1451]	154 to 175 {1571 to 1786} [1363 to 1549]	215 to 270 {2194 to 2755} [1903 to 2389]
300(12mm)		114 to 138 {1163 to 1408} [1009 to 1221]	125 to 145 {1276 to 1480} [1106 to 1283]	164 to 187 {1673 to 1908} [1451 to 1655]	154 to 180 {1571 to 1837} [1363 to 1593]	155 to 199 {1582 to 2031} [1372 to 1761]	175 to 213 {1786 to 2173} [1549 to 1885]	190 to 249 {1939 to 2541} [1681 to 2204]
350(14mm)		158 to 183 {1612 to 1867} [1398 to 1619]	—	245 to 284 {2500 to 2898} [2168 to 2513]	—	152 to 192 {1551 to 1959} [1345 to 1699]	—	274 to 325 {2796 to 3316} [2425 to 2876]
400(16mm)		243 to 261 {2480 to 2663} [2150 to 2310]	—	253 to 275 {2582 to 2806} [2239 to 2434]	—	248 to 331 {2531 to 3378} [2195 to 2929]	—	313 to 395 {3194 to 4031} [2770 to 3496]

\*Please use compressed non-asbestos fiber gasket, PTFE gasket or the gasket which has equal elasticity.

T030309.EPS

Table 3.3.10 Tightening Torque Values for PVC Piping in N-m(kgf-cm) [in-lbf]

Size mm(inch)	Flange Rating	JIS		ANSI		DIN		JIS G3451 F12(75M)
		10K	20K	150	300	PN10	PN16	
15(0.5)		1.1 {11} [10]	—	1.1 {11} [10]	—	—	1.1 {11} [10]	—
25(1)		2.9 {30} [26]	—	2.3 {23} [20]	—	—	2.2 {22} [19]	—
40(1.5)		5.9 {60} [52]	—	4.7 {48} [42]	—	—	5.9 {60} [52]	—
50(2)		7.2 {73} [64]	—	7.2 {73} [64]	—	—	7.2 {73} [64]	—
80(3)		4.9 {50} [43]	—	9.9 {101} [88]	—	—	4.9 {50} [43]	9.9 {101} [88]
100(4)		8.1 {83} [72]	—	8.2 {84} [73]	—	—	8.1 {83} [72]	16.3 {166} [144]
150(6)		29.8 {304} [264]	—	28.5 {291} [252]	—	29.8 {304} [264]	29.8 {304} [264]	32.6 {33} [288]
200(8)		26.3 {268} [233]	—	37.7 {385} [334]	—	39.4 {4.2} [349]	26.3 {268} [233]	43.1 {440} [381]

\*Please select optional code/FRG and use rubber or gasket or others which has equal elasticity.

T030310.EPS

### 3.3.5 Nominal Diameter 500 mm (20") to 2600 (104") Flange Type

#### (1) Mounting Direction

Please mount the Magnetic Flow Tube matching the flow direction of the fluid to be measured with the direction of the arrow mark on the flow tube.



#### IMPORTANT

If it is impossible to match the direction, please never remodel to change direction of the terminal box. In case the measuring fluid flows against the arrow direction, please refer to the section "Reversing Flow Direction" in the Instruction Manual of AM11 Magnetic Converter.



#### CAUTION

When lifting the flow tube, please use the lifting rings (eye bolts or shackle). To assure safety, please keep lifting angle less than 90 degrees as shown in Figure 3.3.6. Please do not shock the installation foundation bracket when installing the flowmeter as the bracket may be damaged.

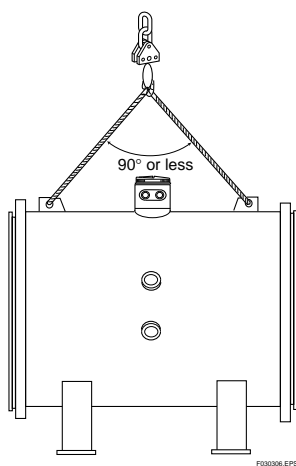

Figure 3.3.6 Lifting Flow Tube

#### (2) Positioning Flow Tube

Please position the flow tube using a jack.



#### IMPORTANT

Please apply the jack to near the flow tube support and insert a steel liner between the bracket and flow tube support. Never use wooden liner.

### (3) Installation Foundation Dimensions

Table 3.3.11 Installation Foundation Dimensions

[Nominal Dia. 500 mm (20") to 1000 mm (40")]

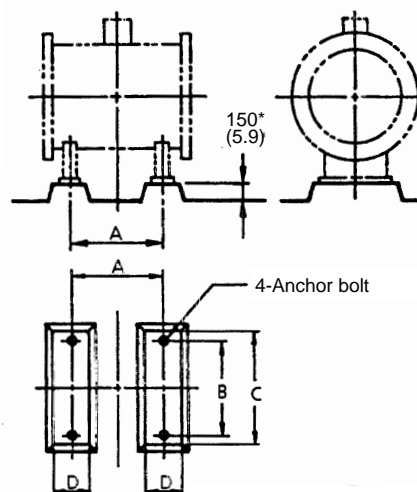

Size: mm (inch)	A	B	C	D
500 (20)	350 (13.8)	350 (13.8)	420 (16.5)	125 (4.9)
600 (24)	400 (15.7)	400 (15.7)	470 (18.5)	125 (4.9)
700 (28)	450 (17.7)	500 (19.7)	570 (22.4)	125 (4.9)
800 (32)	550 (21.7)	550 (21.7)	620 (24.4)	125 (4.9)
900 (36)	700 (27.6)	650 (25.6)	770 (30.3)	125 (4.9)
1000 (40)	800 (31.5)	700 (27.6)	870 (34.3)	125 (4.9)

T030311.EPS

Table 3.3.12 Installation Foundation Dimensions

[Nominal Dia. 1100 mm (44") to 2600 mm (104")]

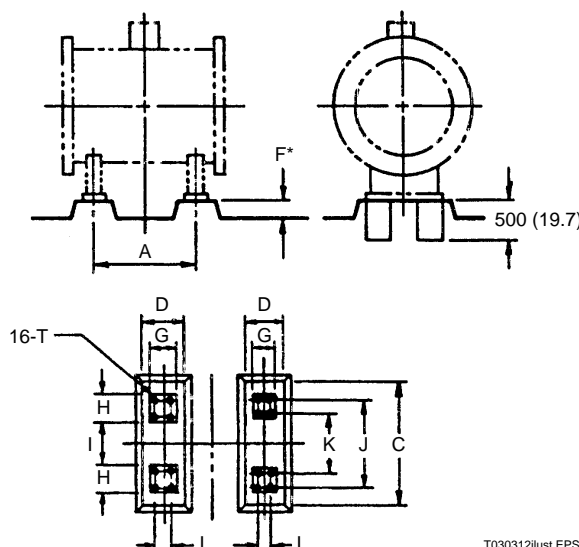

T030312inst.EPS

Size: mm (inch)	Dimensions										
	A	C	D	(F)	G	H	I	J	K	L	T
1,100 (44)	1,211 (47.7)	1,500 (59.1)				450 (17.7)	520 (20.5)	1,100 (43.3)	720 (28.3)		
1,200 (48)	1,261 (49.6)	1,600 (63.0)	600	200*	400	500 (19.7)	540 (21.3)	1,200 (47.2)	780 (30.7)	130	M16*
1,350 (54)	1,366 (53.8)	1,750 (68.9)	(23.6)	(7.9)	(15.7)	550 (21.7)	640 (25.2)	1,350 (53.1)	880 (34.6)	(5.1)	
1,500 (60)	1,490 (58.7)	1,900 (74.8)				600 (23.6)	700 (27.6)	1,500 (59.1)	980 (38.6)		
1,600 (64)	1,698 (66.9)	2,100 (82.7)				650 (25.6)	700 (27.6)	1,650 (65.0)	1,080 (42.5)		
1,800 (72)	1,864 (73.4)	2,250 (88.6)	700	250*	500	700 (27.6)	750 (29.5)	1,800 (70.9)	1,180 (46.5)	170	M20*
2,000 (80)	2,010 (79.1)	2,450 (96.5)	(27.6)	(9.8)	(19.7)	700 (27.6)	1,070 (42.1)	2,000 (78.7)	1,300 (51.2)	(6.7)	
2,200 (88)	2,172 (85.5)	2,700 (106.3)				730 (28.7)	1,200 (47.2)	2,200 (86.6)	1,430 (56.3)	200	M20*
2,400 (96)	2,218 (87.3)	2,900 (114.2)				770 (30.3)	1,330 (52.4)	2,400 (94.5)	1,560 (61.4)	(7.9)	
2,600 (104)	2,300 (90.6)							2,600 (102.4)	1,700 (66.9)		

T030312.EPS

Note 1: See the external dimensions for the support dimensions.

Note 2: The value marked as \* is reference dimensions.

#### (4) Connecting to Pipe

Please pass bolts from pipe line side, not flow tube side, and tighten the bolts according to Torque Values in Table 3.3.9.

#### ! CAUTION

- Please be sure to tighten the bolts following prescribed torque values. Please tighten the flange bolts diagonally with the same torque values, step by step up to the prescribed torque value.
- Please completely cover the brackets and liners with mortar.

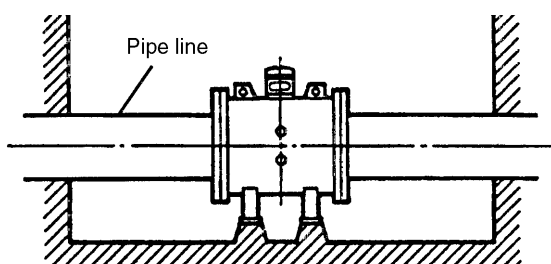

Figure 3.3.7 Mounting Flow Tube

Table 3.3.13 Tightening Torque Values for Metal Piping

Flange Rating Size: mm (inch)	JIS G3451 F12/JIS7.5K			JIS10K			ANSI150		
	N-m	kgf-cm	in-lbf	N-m	kgf-cm	in-lbf	N-m	kgf-cm	in-lbf
500 (20)	121 to 150	1234 to 1530	1071 to 1327	63 to 79	643 to 806	558 to 699	59 to 73	602 to 745	522 to 646
600 (24)	116 to 145	1183 to 1479	1027 to 1283	78 to 97	796 to 989	690 to 858	67 to 84	683 to 857	593 to 743
700 (28)	173 to 215	1765 to 2193	1531 to 1903	104 to 130	1061 to 1326	920 to 1150	—	—	—
800 (32)	180 to 224	1836 to 2285	1593 to 1982	115 to 144	1173 to 1469	1018 to 1274	—	—	—
900 (36)	102 to 127	1040 to 1295	903 to 1124	175 to 182	1785 to 1856	1549 to 1611	—	—	—
1000 (40)	231 to 288	2356 to 2938	2044 to 2549	204 to 254	2081 to 2591	1805 to 2248	—	—	—
1100 (44)	298 to 372	3040 to 3794	2637 to 3292	—	—	—	—	—	—
1200 (48)	301 to 376	3070 to 3935	2684 to 3327	—	—	—	—	—	—
1350 (54)	432 to 539	4406 to 5498	3823 to 4770	—	—	—	—	—	—
1500 (60)	463 to 578	4723 to 5896	4097 to 5115	—	—	—	—	—	—
1600 (64)	488 to 585	4774 to 5967	4142 to 5177	—	—	—	—	—	—
1800 (72)	485 to 605	4947 to 6171	4292 to 5354	—	—	—	—	—	—
2000 (80)	615 to 768	6273 to 7534	5442 to 6796	—	—	—	—	—	—
2200 (88)	686 to 858	6997 to 8752	6071 to 7593	—	—	—	—	—	—
2400 (96)	759 to 948	7742 to 9670	6717 to 8389	—	—	—	—	—	—
2600 (104)	1006 to 1257	10261 to 12821	8903 to 11124	—	—	—	—	—	—

\* Please use rubber gasket or the gasket which has equal elasticity.

T030313.EPS

### 3.3.6 Mounting Procedure for Sanitary Type

The sanitary type is mounted using IDF clamps.

#### (1) Mounting Direction

Please mount the Magnetic Flow Tube matching the flow direction of the fluid to be measured with the direction of the arrow mark on the flow tube.

#### ! IMPORTANT

If it is impossible to match the direction, please never remodel to change direction of the terminal box. In case the measuring fluid flows against the arrow direction, please refer to the section "Reversing Flow Direction" in the Instruction Manual of AM11 Magnetic Converter.

#### (2) Welding of Mating Ferrule to Piping

#### ! IMPORTANT

Weld the attached ferrules to the piping. Please pay attention to the welding condition to avoid deforming piping or making the stagnant portion of the fluid; joint preparation, level difference in butt joint, welding current.

#### (3) Mounting Gasket

Mount the attached gasket so it fits into the groove on the ferrule.

#### (4) Positioning Flow Tube

Position the flow tube between the mating ferrule.

#### (5) Tightening Clamp

Mount the clamp so they cover the flow tube and mating ferrule tapered part.

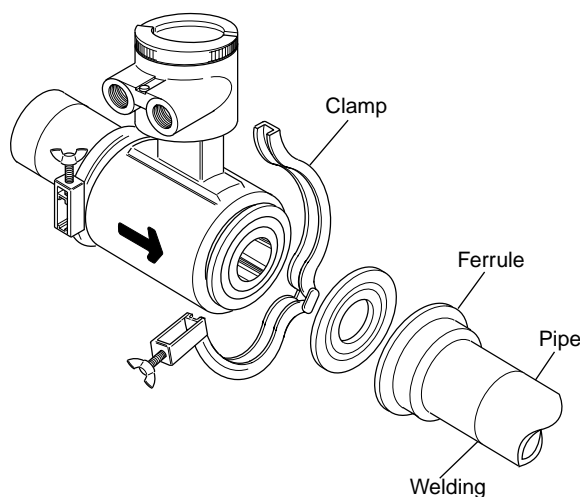

F030308.EPS

Figure 3.3.8 Mounting Procedure

## 3.4 Wiring Precautions

This section is described wiring only for flow tube side. Please see "Wiring" in AM11 Magnetic Flow Converter Instruction Manual for converter side.

### 3.4.1 Protective Grounding



#### CAUTION

Please be sure to connect protective grounding of ADMAG with cable of 2mm<sup>2</sup> or larger cross section in order to avoid the electrical shock to the operators and maintenance engineers and prevent the influence of external noise. And further connect the grounding wire to the  mark (100Ω or less).

### 3.4.2 General Precautions

Please give attention to the followings in wiring.



#### CAUTION

- In case the ambient temperature exceeds 50°C (122°F), please use heat-resistant cable with maximum allowable temperature of 70°C (158°F) or above for JIS flameproof type.
- Please pay attention to avoid the cable is bended excessively.
- Please do not connect cables outdoors in case of rain to prevent damages from dew formation and to keep insulation inside the terminal box of the flow tube.
- Please do not splice the cable between a flow tube and a converter if it is too short. Please replace the short cable with the cable which is appropriate length wholly.
- The all cable ends are to be provided with round crimp-on terminal.
- The signal cables must be routed in separate steel conduit tubes or flexible tubes.
- Please keep conduit or flexible tube water-tight using sealing tape.
- Please ground each of a flow tube and a converter separately.
- Please cover each shield of the signal cable with PVC tube or PVC tape to avoid contacting between two shields; shield and case.
- When waterproof glands or union equipped waterproof glands are used, the glands must be properly tightened to keep the box watertight.

- Please be sure to fully tighten the terminal box cover before the power is turned on.
- Please be sure to turn off the power before opening the terminal box cover.

### 3.4.3 Cable Types

#### (1) Dedicated Signal Cable(AM011)

The flow signal is transmitted via this dedicated cable. The cable is constructed with double shielding over the two conductors, and used heat-resistant vinyl as the outer jacket material.

Finished diameter: 10.5 mm (0.413")

Maximum length: 200 m (660 ft)

Maximum temperature: 80°C (176°F)

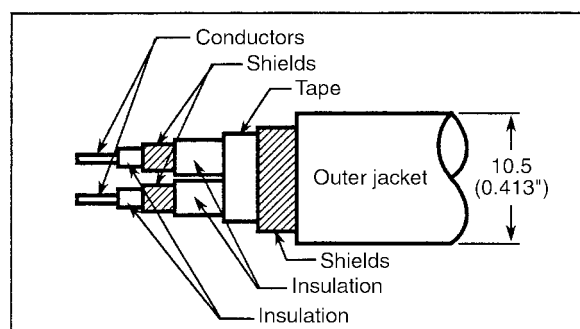

F030401.EPS

Figure 3.4.1 Dedicated Signal Cable AM011



#### IMPORTANT

If the cable is longer than required, cut off any extra length, rather coiling it up, and terminate the conductors as shown in Figure 3.4.2. Avoid using intermediate terminal boards to extend the cable length, or this will interrupt the shielding.

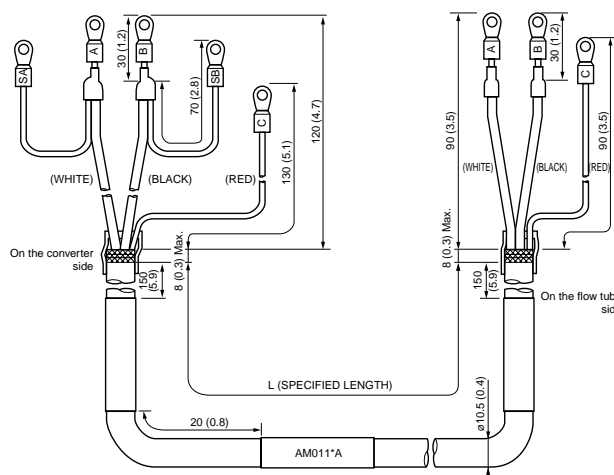

F030402.EPS

Figure 3.4.2 Treatment of Dedicated Signal Cable

**CAUTION**

Since A, B, SA, SB, and C all operate at different electrical potentials, securely insulate them from each other so they do not touch. The shields must not be allowed to touch each other or to touch the case. Cover each shield with vinyl tube or wrap in vinyl tape.

**NOTE**

Conductors A and B carry the signal from the electrodes, and C is at the potentials of the liquid it self (signal common) . Shields SA and SB are kept at the same potentials as the individual electrodes (these are actively driven shields). This is done to reduce the effect of the distributed capacitance of the cable at long cable length. Note that, since the signals from the individual electrodes are impedance converted inside the converter, errors will result if they come in contact with any other component. Great care must be taken in the cable end treatment.

**3.4.4 Connection to AM11Magnetic Flow Converter**

Connect the flow tube and converter in the following method.

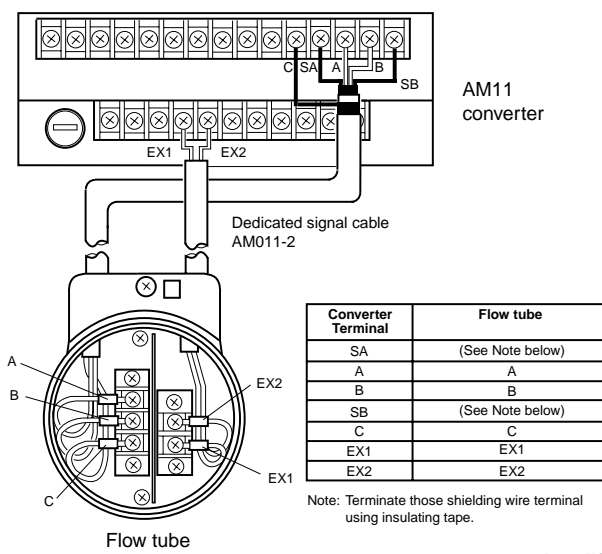

Figure 3.4.4 Connection

**(2) Excitation Cable**

Please use Polyvinyl chloride insulated and sheathed control cables (JIS C3401) or Polyvinyl chloride insulated and sheathed portable power cables (JIS C3312) or equivalents.

**Outer Diameter**

- 6.5 to 12mm in diameter (7.5 to 12 mm for water-proof gland / ECG, /ECU, /ECW)

**Nominal Cross Section**

- Single wire; 0.5 to 2.5mm<sup>2</sup> , Stranded wire; 0.5 to 2.5mm<sup>2</sup>

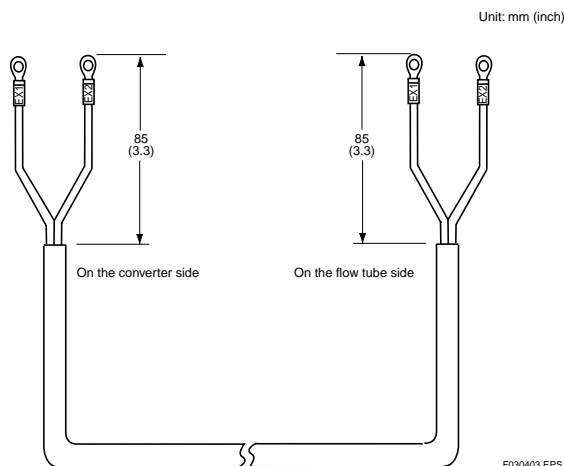

Figure 3.4.3 End Treatment of Excitation Cable

### 3.4.5 Wiring Ports

Please select the most suitable standard of wiring procedure for the wiring ports by customer's own.

#### A : Using the Waterproof Gland



#### IMPORTANT

To prevent water or condensate from entering the converter housing, waterproof glands are recommended. Do not over-tighten the glands or damage to the cables may result. Tightness of the gland can be checked by confirming that the cable is held firmly in place.

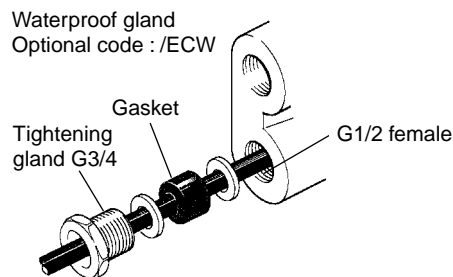
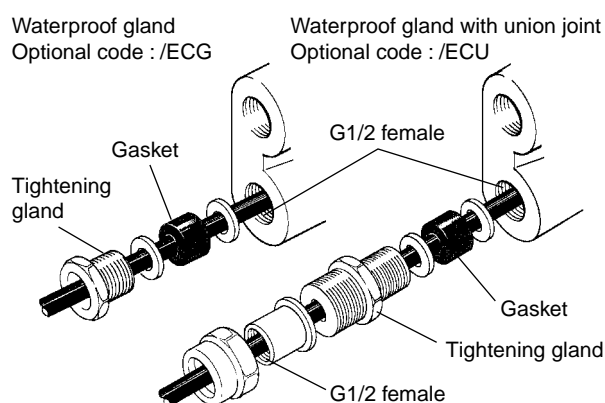

F030406.EPS

Figure 3.4.6 Waterproof Gland

#### B : Insulation Check

After wiring is completed, check insulation of the following terminals together with the wiring under the condition of the converter side wiring terminals disconnected.

- Between terminal EX1 and terminal A, B, C
- Between terminal C and terminal A, B
- Between terminal A and terminal B
- Between terminal EX1 and ground
- Between terminal EX2 and ground

All insulation measurements must be performed with a 500V megger. Insulation resistances must be 100MΩ or more each.



#### IMPORTANT

Be sure to disconnect the cables at the terminal of the converter when checking insulation.

#### C : Conduit Wiring

In case of conduit wiring, please use the waterproof gland to prevent water flowing through the conduit pipe into the wiring connection.

Please slope the conduit pipe down, and install a drain valve at the low end of the vertical pipe.

Please open the drain valve regularly.

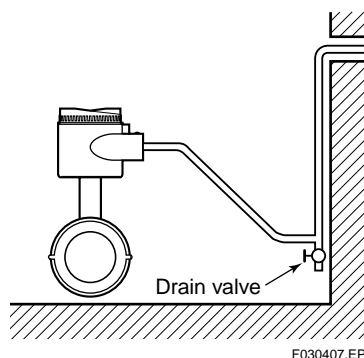

F030407.EPS

Figure 3.4.7 Conduit Wiring

# 4. MAINTENANCE



## WARNING

This instrument must be repaired or maintenance-serviced by expert engineer or skilled personnel. The procedures described in this chapter are not permitted for operators.

Regular maintenance and inspection should be carried out to fully utilize all functions and to obtain maximum performance from the magnetic flowmeter.

## 4.1 Regular Inspection Items

- (1) **Inspection of moisture-proofing inside the terminal box: Once/year**
- (2) **Refastening of piping joint screws: About twice/year**
- (3) **Inspection of electrodes and lining (in case of adhesive and/or abrasive fluid, etc.)**  
Determine the period of regular inspection as necessary.

## 4.2 Trouble Shooting

Since the ADMAG magnetic flowmeter has “self diagnostic functions”, if a failure occurs, it is displayed on the AM11 magnetic flow converter. Please refer to Instruction Manual of AM11 magnetic flow converter.



## IMPORTANT

Be sure to disconnect the cables at the terminals of the flow tube when checking.

### (1) Excitation Coil Check

Check that the resistance between terminals EX1 and EX2 in the terminal box is 150 Ω or less with a multimeter. If it is not, coils may be broken down, and replacement or repair of the flow tube is needed.

### (2) Insulation Resistance Check

Check the insulation resistances in accordance with the tables below. If one of them falls below the value in the tables, replacement or repair of the flow tube is needed. In case of submersible type flowmeter, release wiring connection of converter side and measure resistance at cable terminations.

#### Coil Circuit

Checking is possible even if the pipe is filled with fluid.

Test Terminals	Test Voltage	Specification
Between Terminals EX1 and C	500 V DC	1MΩ or more

T0401.EPS

#### Signal Circuit

Be sure to empty and dry the pipe inside, and release wiring connection of converter side before checking.

Test Terminals	Test Voltage	Specification
Between Terminals A and C Between Terminals B and C	500 V DC	100MΩ or more for each

T0402.EPS



# 5. OUTLINE

## STANDARD SPECIFICATIONS

### Protection:

General Purpose /Explosion proof /Sanitary Type:  
IP67, NEMA4X, JIS C0920 water tight  
type.

Submersible Type: JIS C0920 submersible type, IP68.  
(Test Condition: 50m below the surface of  
the water, equivalent to 0.5MPa hydraulic  
pressure, for one month. If always under  
water or corrosion fluid, contact  
Yokogawa office.)

### Size:

General Purpose type

Lining	Fluorocarbon PFA	Ceramic	Polyurethane
Size in mm (inch)	2.5(0.1), 5(0.2), 10(0.4),15(0.5), 25(1), 40(1.5), 50(2), 65(2.5), 80(3), 100(4), 125(5), 150(6), 200(8),250(10), 300(12),350(14), 400(16)	2.5(0.1), 5(0.2), 10(0.4), 15(0.5), 25(1), 40(1.5), 50(2), 80(3), 100(4), 150(6), 200(8)	25(1), 40(1.5), 50(2), 80(3), 100(4), 150(6), 200(8), 250(10), 300(12), 350(14), 400(16), 500(20), 600(24), 700(28), 800(32), 900(36), 1000(40),1100(44),1200(48), 1350(54), 1500(60), 1600(64), 1800(72),2000(80), 2200(88), 2400(96), 2600(104)

Submersible type

Lining	PFA	Polyurethane
Size in mm (inch)	25(1), 40(1.5), 50(2), 80(3), 100(4), 150(6), 200(8), 250(10), 300(12), 350(14), 400(16)	25(1), 40(1.5), 50(2), 80(3), 100(4), 150(6), 200(8), 250(10), 300(12), 350(14), 400(16),500(20), 600(24), 700(28), 800(32),900(36), 1000(40),1100(44), 1200(48), 1350(54), 1500(60),1600(64), 1800(72),2000(80), 2200(88),2400(96), 2600(104)

Explosion proof type

Lining	PFA/Ceramic
Size in mm (inch)	2.5(0.1), 5(0.2), 10(0.4), 15(0.5),25(1), 40(1.5), 50(2), 80(3), 100(4), 150(6), 200(8)

Sanitary type\*1

Lining	PFA
Size in mm (inch)	25(1), 40(1.5), 50(2), 65(2.5), 80(3), 100(4),

\*1: 15, 125mm for Sanitary type flow  
tubes are available on request.

### Coating:

General Purpose /Explosion Proof /Sanitary Type:  
Body: Size 2.5 to 100 mm (0.1 to 4in.); No  
coating (Stainless steel surface)  
Size 125mm (5in.) or more; Polyure-  
thane corrosion-resistant coating  
Frosty-white (Munsell 2.5Y8.4/1.2)

Terminal box : Polyurethane corrosion-resistant  
coating

Case; Frosty white (Munsell 2.5Y8.4/1.2)

Cover; Deep sea moss green (Munsell  
0.6GY3.1/2.0)

Submersible type: Non-tar epoxy coating(Black)

### Flow Tube Material:

Size 2.5 to 15 mm (0.1 to 0.5in.)

Housing: Stainless steel(SCS11)

Flange (15mm(0.5 in.)only) : Stainless  
steel.(SUS304)

Pipe: Stainless steel (SCS13)\*or Alumina  
ceramic (99.9%)

Terminal box : Aluminum alloy.

Size 25 to 100 mm (1 to 4in.)

Housing: Stainless steel(SUS304)

Flange : Stainless steel (SUS304)

Pipe: Stainless steel (SUS304)\*or Alumina  
ceramic (99.9%)

Terminal box : Aluminum alloy.

Size 125 to 400 mm (5 to 16in.)

Housing: Carbon steel

Flange Carbon steel

Pipe: Stainless steel (SUS304)\*or Alumina  
ceramic (99.9%, only for size 150mm  
and 200mm (6 and 8in.)

Terminal box : Aluminum alloy.

\* For PFA or Polyurethane lining

Size 500 to 2600 mm (20 to 104in.)

Housing: Carbon steel

Flange Carbon steel

Pipe: Stainless steel (SUS304)

Terminal box:cover; Aluminum alloy  
case; Stainless steel (SUS304)

### Wetted Part Material:

Lining: Fluorocarbon PFA, Alumina ceramic,  
Polyurethane

Electrode: Stainless steel (SUS316L), Hastelloy C  
(equivalent to Hastelloy C-276), Titanium,  
Tantalum, Platinum-Iridium, Platinum-  
alumina cermet only for ceramic lining.

\*For size over 500mm and sanitary type,  
SUS316L only

Earth Ring/Earth Electrode:Stainless steel (SUS316),  
Hastelloy C (equivalent to Hastelloy C-  
276), Titanium,SUS304,(Size 500 to  
1000mm (20 to 40in.), SS400 lined with  
SUS316 (Size 1100 to 2600mm (40 to  
104in.) ), PFA lining+Earth electrodes  
(Tantalum, Platinum-Iridium).

Note: Hastelloy is a registered trademark of  
Haynes International Inc.

Gasket: • VALQUA#7020;Fluoro resin with filler  
(between flow tube body and earth ring;  
for ceramic lining)

• VALQUA#4010;Fluoro rubber, viton  
(between flow tube body and earth ring;  
for optional code /FRG)

• Non-asbestos joint sheet sheathed with  
fluoro resin (between earth ring and  
process flange; for optional code /BCF or  
/BSC)

• Chloroprene rubber (between earth ring  
and process flange; for optional code  
/BCC or /BSC)

• EPDM, ethylene propylene rubber (for  
sanitary type)

\* Other gaskets between flow tube body and earth ring;

• VALQUA#7026;corrosion resistance gasket  
(Fluoro resin with carbon)

• VALQUA#4010(Mixing#RCD970);Alkali  
resistance gasket for PVC piping (Fluoro  
rubber)

• VALQUA#4010(Mixing#RCD470);Acid  
resistance gasket for PVC piping (Fluoro  
rubber)

Contact Yokogawa office. (Refer to TI  
1E6A0-06E)

Union Joint:Stainless steel (SUS316L), for ceramic  
lining size 10mm (0.4in.) or less\*

\*Contact Yokogwa office if PVC union joints are required.  
Ferrule(for sanitary type):SCS13

**Electrode Construction:**

- **General Purpose/Ex-proof/Submersible type**  
PFA, Polyurethane Linings: External Insertion type.  
Ceramic Lining: Integral type.
- **Sanitary type**  
Internal Insertion type.  
\* Only PFA lining is available for sanitary type

**Electrical Connection:**

JIS G1/2(PF1/2)female, ANSI 1/2NPT female,  
DIN Pg13.5 female, ISO M20X1.5 female

**Terminal Connection:**

M4 size screw terminal.

**Grounding:**

100Ω or less

\* In case of JIS Flameproof type, JIS Class C(10Ω or less) or JIS Class A(10Ω or less)

## HAZARDOUS AREA CLASSIFICATION AM100 / 200DN

**FM:**

- Explosion proof for Class I, Division 1, Groups A, B, C & D. Dust-ignitionproof for Class II/III, Division 1, Groups E, F & G. Intrinsically safe (electrode) for Class I, Division 1, Groups A, B, C & D.  
Electrode Circuit Vmax: 250V ac/dc  
Temp. Class. T6  
Enclosure: NEMA 4X
- Nonincendive for Class I, Division 2, Groups A, B, C & D; Suitable for Class II, Division 2, Groups F & G; Class III, Division 1 and 2. Intrinsically safe (electrode) for Class I, Division 1, Groups A, B, C & D.

Electrode Circuit Vmax: 250V ac/dc

Excitation Circuit: 130Vp 72/75 Hz

Temp. Class. T5

Enclosure: NEMA 4X

- \* Installation shall be in accordance with the manufacturer's instructions and the National Electric Code, ANSI/NFPA-70.

**CENELEC****KEMA No. Ex-94.C.8524**

EEx dm[ia]IIC T6...T4

Electrode Circuit Vmax: 250V ac/dc

Excitation Circuit: 130Vp 72/75 Hz

Temp. Class T6 T5 T4 T3

Process Temp. 70 85 120 150°C

**CSA :**

- Nonincendive for Class I, Division 2, Groups A, B, C & D; Suitable for Class II, Division 2, Groups F & G; Class III, Division 2. Intrinsically safe (electrode) for Class I, Division 1, Groups A, B, C & D.  
Electrode Circuit Vmax: 250V ac/dc  
Excitation Circuit: 130Vp 72/75 Hz, 11 Vmax  
Temp. Class T5 T4 T3  
Process Temp. 85 120 150°C  
Enclosure: Type 4

**JIS:**

- Exde[ia]II C T4X  
Converter, Terminal box ; Explosion proof  
Flow Tube ; Increased Safety  
Signal Circuit ; Intrinsically Safety(ia)  
Ambient Temperature : -10°C to 60 °C\*  
Fluid Temperature : 120°Cmax.  
Electrode Circuit : 250V AC/DC  
Grounding : JIS Class C(10Ω or less) or JIS Class A(10Ω or less)

\* In case the ambient temperature exceeds 50°C, use heat-resistant cables with maximum allowable temperature of 70°C or above.

## STANDARD PERFORMANCE

**Accuracy:**

PFA and Ceramic Lining

Vs: Span setting value (m/s)

Size in mm (inch)	Span in m/s (ft/s)	Accuracy
2.5 to 15 (0.1 to 0.5)	0.1 to 0.3(0.3 to 1)	0.15/Vs % of span
	0.3 to 1(1 to 3)	0.5% of span
	1 to 3 (3 to 33) (both included)	0.25% of span (at indications below 50%)
0.5% of flowrate indication (at indications 50% of span or more)		
25 to 400 (1 to 16)	0.1 to 0.3(0.3 to 1)	0.075/Vs % of span
	0.3 to 1 (1 to 3)	0.25% of span (at indications below 50% of span)
		0.5% of flowrate indication (at indications 50% of span or more)
1 to 10(3 to 33) (both included)	0.1% of span (at indications below 20% of span)	
	0.5% of flowrate indication (at indications 20% of span or more)	

T02.EPS

**Polyurethane Lining**

Vs: Span setting value (m/s)

Size in mm (inch)	Span in m/s (ft/s)	Accuracy
25 to 400 (1 to 16)	0.1 to 0.3(0.3 to 1)	0.15/Vs % of span
	0.3 to 1(1 to 3)	0.5% of span
	1 to 10 (3 to 33)	0.25% of span (at indications below 50% of span)
0.5% of flowrate indication (at indications 50% of span or more)		
500 to 1000 (20 to 40)	0.1 to 0.3(0.3 to 1)	0.225/Vs % of span
	0.3 to 1(1 to 3)	0.75 % of span
	1 to 10 (3 to 33)	0.5% of span
1100 to 2000 (44 to 80)	0.3 to 1(1 to 3)	0.75 % of span
	1 to 10(3 to 33)	0.5% of span
2200 to 2600 (88 to 104)	0.3 to 1(1 to 3)	1/Vs % of span
	1 to 10(3 to 33)	1% of span

T03.EPS

**Repeatability:**

0.1% of flowrate (1mm/s Minimum)

**Maximum Power Consumption:**

28W (for combination with AM11 converter).

**Insulation Resistance:**

- 100MΩ between excitation terminal and each signal terminal at 500V DC.
- 100MΩ among signal terminals at 500V DC.

**Withstand Voltage****(Except for ex-proof type):**

- 1000V AC or 1400 V DC between excitation terminal and ground terminal for 1 minute.

**(Ex-proof type):**

- 1500V AC between excitation terminal and ground terminal for 1 minute.
- 500V AC between each signal terminal and ground terminal for 1 minute.
- 1760V AC between each signal terminal and each excitation terminal for 1 minute.

**CAUTION**

When performing the Voltage Breakdown Test, Insulation Resistance Test or any unpowered electrical test, wait 10 seconds after the power supply is turned off before removing the housing cover. Be sure to remove the Short Bar at terminal "G". After testing, return the Short Bar to its correct position. Screw tightening torque should be 12kg-cm(0.88ft-lb) or more, because the G-terminal is thought as a protective grounding and should conform to the Safety Requirements.

**NORMAL OPERATING CONDITION**

**Ambient Temperature:**

-10 to 60°C (14 to 140°F)

**Ambient Humidity:**

5 to 95%RH (No condensation)

**Power Supply:**

Supplied from magnetic flow converter

**Measurable Flowrate**

SI Units (Size : mm, Flowrate : m³/h) English Units (Size : inch, Flowrate : GPM)

Size	Min. Flowrate @0.1m/s	Max. Flowrate @10m/s	Size	Min. Flowrate @0.33ft/s	Max. Flowrate @33ft/s
2.5	0.0018	0.1767	0.1	0.0081	0.8031
5	0.0071	0.7068	0.2	0.0322	3.212
10	0.0283	2.8274	0.4	0.1286	12.850
15	0.0637	6.361	0.5	0.2008	20.078
25	0.1768	17.671	1	0.8032	80.31
40	0.4524	45.23	1.5	1.8071	180.70
50	0.7069	70.68	2	3.213	321.2
65	1.1946	119.45	2.5	5.020	501.9
80	1.8096	180.95	3	7.229	722.8
100	2.8275	282.74	4	12.851	1,285.0
125	4.418	441.7	5	20.079	2007.8
150	6.362	636.1	6	28.914	2,891.3
200	11.310	1,130.9	8	51.41	5,140
250	17.672	1,767.1	10	80.32	8,031
300	25.447	2,544.6	12	115.66	11,565
350	34.64	3,463	14	157.42	15,741
400	45.24	4,523	16	205.61	20,560
500	70.69	7,068	20	321.3	32,125
600	101.79	10,178	24	462.7	46,261
700	138.55	13,854	28	629.7	62,966
800	180.96	18,095	32	822.5	82,242
900	229.03	22,902	36	1040.9	104,087
1000	282.75	28,274	40	1285.1	128,503
Size	Min. Flowrate @0.3m/s	Max. Flowrate @10m/s	Size	Min. Flowrate @1.0ft/s	Max. Flowrate @33ft/s
1100	1,026.4	34,211	44	4,665	155,489
1200	1,221.5	40,715	48	5,552	185,045
1350	1,545.9	51,529	54	7,026	234,197
1500	1,908.6	63,617	60	8,674	289,133
1600	2,171.5	72,382	64	9,870	328,969
1800	2,748.3	91,608	72	12,491	416,351
2000	3,393	113,097	80	15,421	514,014
2200	4,106	136,847	88	18,659	621,957
2400	4,886	162,860	96	22,206	740,181
2600	5,735	191,134	104	26,061	868,684

\* Measurable flow velocity is from 0m/s(ft/s).

T04.EPS

**Distance between Flow Tube and Converter:**

Size 15 mm(0.5in.) to 400mm(16in.)

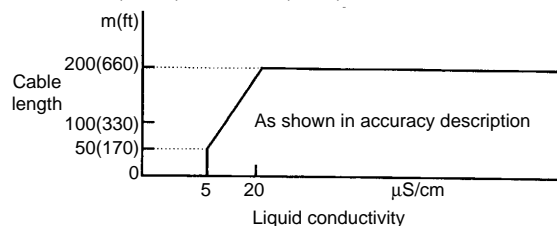

PFA, Size 2.5 to 10mm (0.1 to 0.4in.)

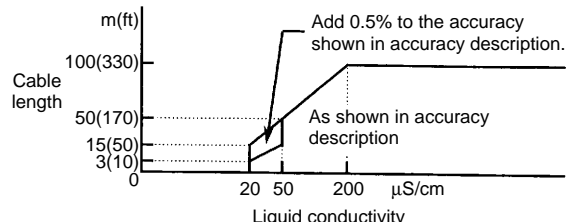

Ceramics, Size 2.5 to 10mm (0.1 to 0.4in.)

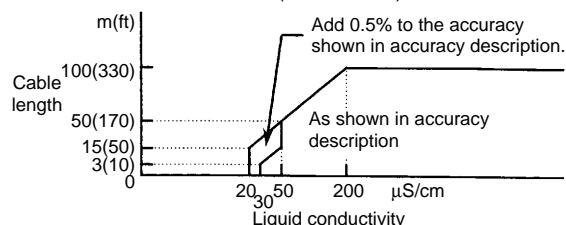

F01.EPS

\* In case of size 500mm(20in.) or larger, the maximum cable length is 200m(660ft) and the minimum conductivity is 50µS/cm.

**Fluid Temperature and Pressure:**

**PFA Lining**

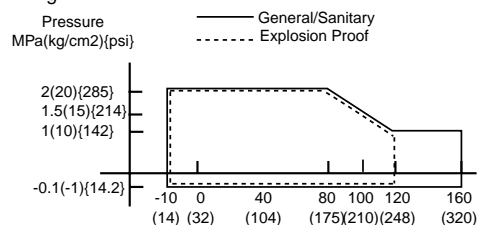

**Ceramics Lining**

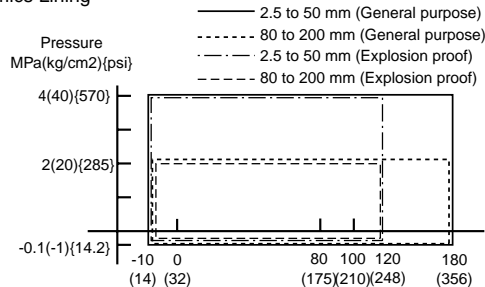

**Polyurethane Lining**

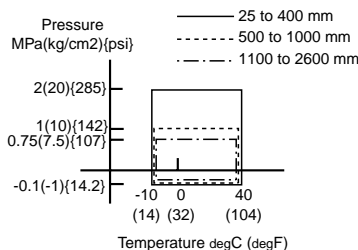

F02.EPS

**Reasonable Figures for Thermal Shock of Ceramic Lining:**

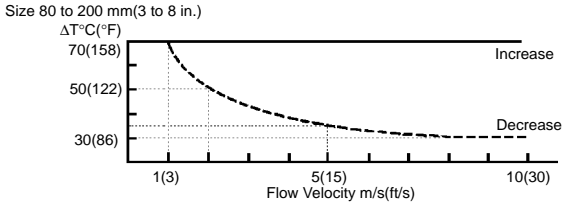
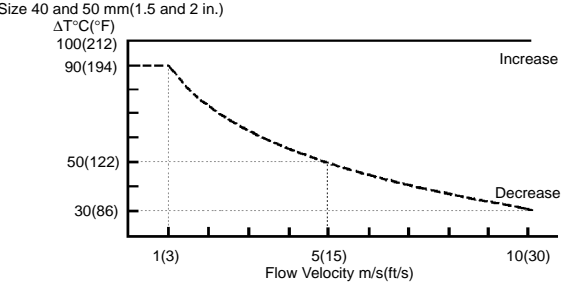
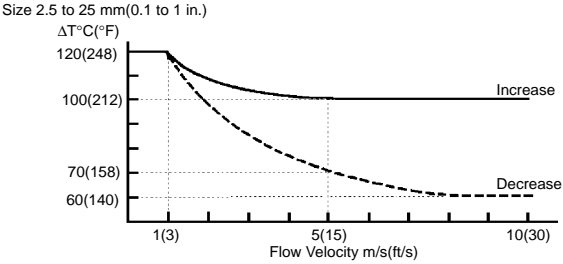

F03.EPS

**ACCESSORIES**

- Centering device (Wafer type) 1set
- Hexagonal Wrench (JIS Flameproof type) 2sets
- Hexagonal Wrench (Ex-proof type except JIS) 1set

**TERMINAL CONNECTION**

Terminal symbols	Description
<ul style="list-style-type: none"> <li>[ A</li> <li>[ B</li> <li>[ C</li> </ul>	] Flow signal output
<ul style="list-style-type: none"> <li>[ EX1</li> <li>[ EX2</li> </ul>	] Exciting current input
	Protective grounding (outside of the terminal box)

T06.EPS

**GASKET**

Please use compressed non-asbestos fiber gasket, PTFE gasket or the gasket which has equal elasticity. In case of optional code/FRG, please use rubber gasket or others which has equal elasticity.

**SIZING DATA**

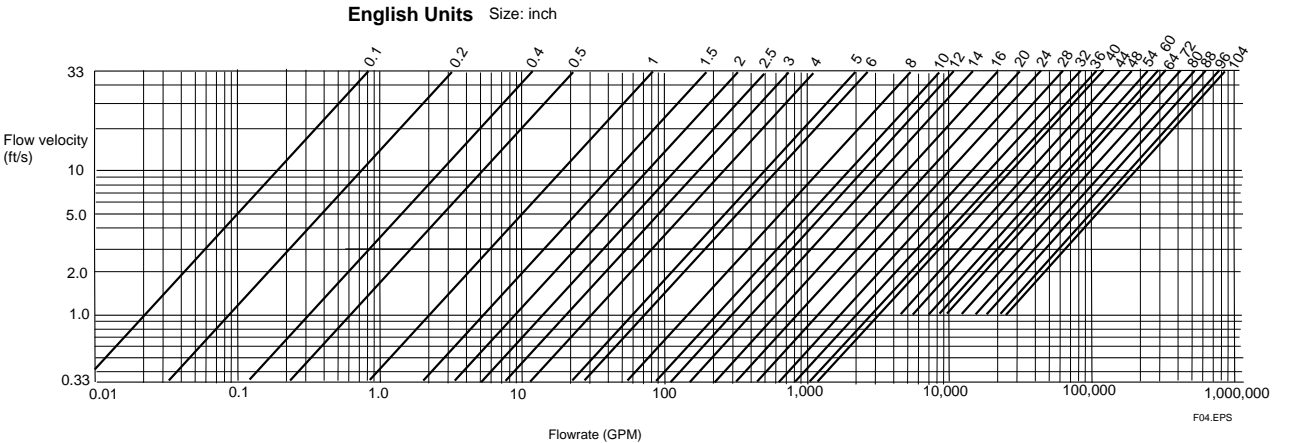
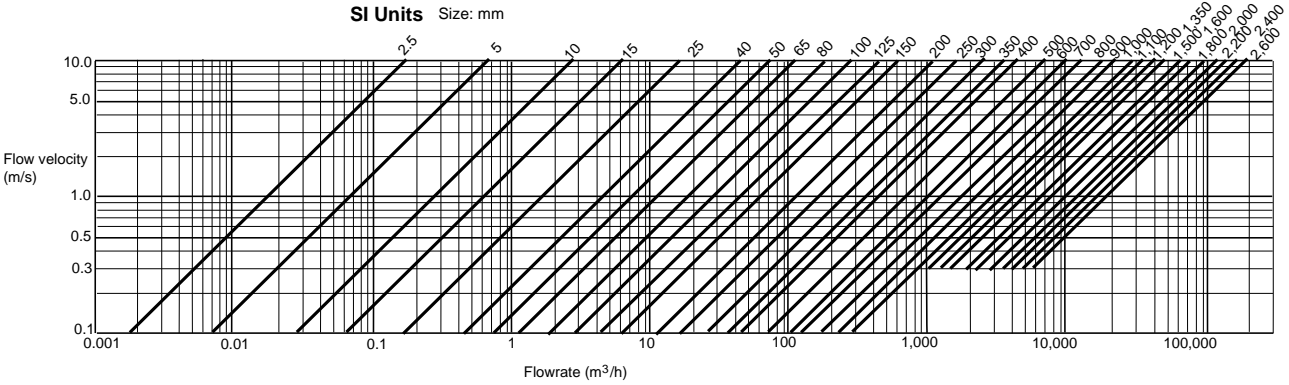

F04.EPS

\* Measurable flow velocity is from 0 m/s.

## MODEL AND SUFFIX CODE

- General purpose/Explosion proof/Submersible Type AM100D, 200D

Model	Suffix code	Description	Application										A: Available N: Not Available
			G		C		N		W				
			Lining material										
			A	U	C	A	C	A	C	A	U		
AM102D		Size 2.5 mm (0.1in.)	A	N	A	A	A	A	A	N	N	Note 1 Note 1 Note 1 Note 1	
AM105D		Size 5 mm (0.2in.)	A	N	A	A	A	A	A	N	N		
AM110D		Size 10 mm (0.4in.)	A	N	A	A	A	A	A	N	N		
AM115D		Size 15 mm (0.5in.)	A	N	A	A	A	A	A	N	N		
AM202D		Size 25 mm (1in.)	A	A	A	A	A	A	A	A	A		
AM204D		Size 40 mm (1.5in.)	A	A	A	A	A	A	A	A	A		
AM205D		Size 50 mm (2in.)	A	A	A	A	A	A	A	A	A		
AM206D		Size 65 mm (2.5in.)	A	N	N	N	N	N	N	N	N		
AM208D		Size 80 mm (3in.)	A	A	A	A	A	A	A	A	A		
AM210D		Size 100 mm (4in.)	A	A	A	A	A	A	A	A	A		
AM212D		Size 125 mm (5in.)	A	N	N	N	N	N	N	N	N		
AM215D		Size 150 mm (6in.)	A	A	A	A	A	A	A	A	A		
AM220D		Size 200 mm (8in.)	A	A	A	A	A	A	A	A	A		
Use	G W N C	General purpose	A	A	A	N	N	N	N	N	N		Note 4 Note 5
		Submersible	N	N	N	N	N	N	N	A	A		
		CENELEC, FM, CSA Ex.proof	N	N	N	N	N	A	A	N	N		
		JIS Flameproof	N	N	A	A	N	N	N	N	N		
Lining	-A -U -C	Fluorocarbon PFA	A	N	N	A	N	A	N	A	N		
		Polyurethane	N	A	N	N	N	N	N	N	A		
		Ceramic	N	N	A	N	A	N	A	N	N		
Process connection Note 3	K1 K2 B1 B2 E2 H1 J1 J2 A1 A2 D1 D2 G1 U1 U2 U3	JIS 10K wafer	A	A	A	A	A	A	A	A	A	Not available with 65/125mm	
		JIS 20K wafer	A	A	A	A	A	A	A	A	A		
		ANSI 150 wafer	A	A	A	A	A	A	A	A	A	Not available with 65/125mm	
		ANSI 300 wafer	A	A	A	A	A	A	A	A	A		
		DIN PN10/16 wafer	A	A	A	A	A	A	A	A	A	Size 80mm or larger	
		JIS F12 (JIS75M) wafer	A	A	A	A	A	A	A	A	A		
		JIS 10K flange	A	A	N	A	N	A	N	A	A	Not available with 65/125mm	
		JIS 20K flange	A	A	N	A	N	A	N	A	A		
		ANSI 150 flange	A	A	N	A	N	A	N	A	A	Size 150/200mm only	
		ANSI 300 flange	A	A	N	A	N	A	N	A	A		
		DIN PN10 flange	A	A	N	A	N	A	N	A	A	Note 2	
		DIN PN16 flange	A	A	N	A	N	A	N	A	A		
		JIS F12 (JIS75M) flange	A	A	N	A	N	A	N	A	A	Ceramic lining, size 2.5/5/10mm only	
		Union joint (weld joint)	N	N	A	N	A	N	A	N	N		
Union joint (R1/4 or R3/8)	N	N	A	N	A	N	A	N	N				
Union joint (1/4NPT or 3/8NPT)	N	N	A	N	A	N	A	N	N				
Electrode material	-L -P -E -H -T -V	SUS316L	A	A	N	A	N	A	N	A	A	Not available with 65/125mm	
		Platinum-iridium	A	N	N	A	N	A	N	N	N		
		Platinum-alumina cermet	N	N	A	N	A	N	A	N	N		
		Hastelloy C 276 equivalent	A	N	N	A	N	A	N	N	N		
		Tantalum	A	N	N	A	N	A	N	N	N		
Titanium	A	N	A	N	A	N	A	N	N				
Earth ring Earth electrode material	S P N H T V	SUS316	A	A	A	A	A	A	A	A	A	Note 6 Ceramic size 2.5/5/10mm only Not available with 65/125mm Note 6 Not available with 65/125mm	
		Platinum-iridium electrode	A	N	A	A	A	A	A	N	N		
		None	N	N	A	N	A	N	A	N	N		
		Hastelloy C276 equivalent	A	N	A	A	A	A	A	N	N		
		Tantalum	A	N	A	A	A	A	A	N	N		
		Titanium	A	N	A	A	A	A	A	N	N		
Electrical connection	J A D M	JIS G1/2 (PF1/2)female	A	A	A	A	A	N	N	A	A		
		ANSI 1/2NPT female	A	A	A	N	N	A	A	N	N		
		DIN Pg13.5 female	A	A	A	N	N	A	A	N	N		
		ISO M20 X 1.5 female	A	A	A	N	N	A	A	N	N		
Style code	*A	Style A											
Optional specification	Refer to optional specification code												

- Note 1: Process connection for size 2.5 to 10mm(0.1 to 0.4in.), wafer type is equal to one for 15mm(0.5in.).  
Provide 15mm process flanges for these flow tubes. Not available with 65, 125mm.
- Note 2: Select PN16 when requirement of PN10 for size 100mm(4in.)or less because of same mating dimensions.
- Note 3: Flange type is available for size 15mm or larger, PFA or Polyurethane lining.
- Note 4: Select ANSI 1/2NPT female electrical connection(code A) in case of requirement of FM/CSA explosion proof type.  
For CENELEC explosion proof type, select ANSI 1/2NPT (code A), DIN Pg13.5(code D) or ISO M20×1.5(code M) electrical connection.
- Note 5: Select JIS G1/2 female electrical connection (code J) and optional code /JF3 with /G12 in case of requirement of JIS Flameproof type.
- Note 6: Platinum-iridium and Tantalum earth electrodes are not available with 65, 125mm and ceramics 150, 200mm.

T07.EPS

• General purpose/Submersible Type AM300D

Model	Suffix code	Description	Application			A: Available N: Not Available
			G	W		
			Lining material			
			A	U	U	
AM325D AM330D AM335D AM340D	..... ..... ..... .....	Size 250 mm (10in.) Size 300 mm (12in.) Size 350 mm (14in.) Size 400 mm (16in.)	A A A A	A A A A	A A A A	
Use	G W	General purpose Submersible	A N	A N	N A	
Lining	-A -U	Fluorocarbon PFA Polyurethane	A N	N A	N A	
Process	J1 J2 A1 A2 D1 D2 G1	JIS 10K flange JIS 20K flange ANSI 150 flange ANSI 300 flange DIN PN10 flange DIN PN16 flange JIS G3451 F12 flange	A A A A A A A	A A A A A A A	A A A A A A A	Only for size 250 or 300 mm(10 or 12in.)  Only for size 250 or 300 mm(10 or 12in.)  Only for size 250 or 300 mm(10 or 12in.)
Electrode material	-L -P -H -T -V	SUS316L Platinum-iridium Hastelloy C 276 equivalent Tantalum Titanium	A A A A A	A N N N N	A N N N N	
Earthing	S H V	SUS316 Hastelloy C 276 equivalent Titanium	A A A	A N N	A N N	
Electrical connection	J A D M	JIS G1/2(PF1/2)female ANSI 1/2NPT female DIN Pg13.5 female ISO M20X1.5 female	A A A A	A A A A	A A A A	
—		-000	Always-000			
Style code	*A		Style A			
Optional specification	<input type="checkbox"/>		Refer to optional specification table			

T08.EPS

• General purpose/Submersible Type AM400D/AM500D

Model	Suffix code	Description
AM405D AM406D AM407D AM408D AM409D AM410D AM511D AM512D AM513D AM515D AM516D AM518D AM520D AM522D AM524D AM526D		Size: 500 mm (20in.) Size: 600 mm (24in.) Size: 700 mm (28in.) Size: 800 mm (32in.) Size: 900 mm (36in.) Size: 1000 mm (40in.) Size: 1100 mm (44in.) Size: 1200 mm (48in.) Size: 1350 mm (54in.) Size: 1500 mm (60in.) Size: 1600 mm (64in.) Size: 1800 mm (72in.) Size: 2000 mm (80in.) Size: 2200 mm (88in.) Size: 2400 mm (96in.) Size: 2600 mm (104in.)
Use	G W	General purpose Submersible
Lining	— U	Polyurethane
Process connection	J1 *1 A1 *2 G1 *3 W1 *4	JIS 10K Flange ANSI Class 150 Flange JIS G3451 F12 Flange JIS 7.5K Flange
Electrode material	— L	SUS316L
Earth ring material	S	SUS304(for AM400) SS400 lined with SUS316(for AM500)
Wiring port	J A *1	JIS G1/2(PF1/2) female ANSI 1/2NPT female
—		-000
—		Always -000
Style code	*A *C *5	Style A Style C
Optional specification	<input type="checkbox"/>	
		Refer to optional specification table

\*1 Size 500 to 1000mm(20 to 40in.)  
\*2 Size 500/600mm(20/24in.)  
\*3 Size 500 to 1500mm(20 to 60in.)  
\*4 Size 1600mm(64in.) or larger  
\*5 Size 1100mm(44in.) or larger

T09.EPS

- Sanitary Type

Model	Suffix code	Description
AM202DH	.....	Size 25 mm (1in.)
AM204DH	.....	Size 40 mm (1.5in.)
AM205DH	.....	Size 50 mm (2in.)
AM206DH	.....	Size 65 mm (2.5in.)
AM208DH	.....	Size 80 mm (3in.)
AM210DH	.....	Size 100 mm (4in.)
Lining	-A .....	Fluorocarbon PFA
Process connection	C1 .....	IDF clamp
Electrode material	-L .....	SUS316L
Earthing	N .....	None
Wiring port	J .....	JIS G1/2(PF1/2)female
	A .....	ANSI 1/2NPT female
	D .....	DIN Pg13.5 female
	M .....	ISO M20X1.5 female
Style code	*A	Style A
Optional specification	<input type="checkbox"/>	Refer to optional specification code

T10.EPS

## Optional Specifications

A : Available N : Not available

Item	Specification	Applicable Model					Code
		General	Ex-proof	Submersible	Sanitary		
		AM***DG	AM***DC	AM***DN	AM***DW	AM***DH	
Stainless steel tag plate	Stainless steel (SUS304) tag plate is fixed with screws.	A	A	A	N	A	/SCT
Waterproof Gland	Waterproof glands are attached to all wiring ports. For JIS G1/2 only.	A	N	N	N	A	/ECG
Waterproof Gland with Union Joint	Waterproof glands (union joint) are attached to all wiring ports. For JIS G1/2 only.	A	N	N	Standard (Note 1)	A	/ECU
Gasket for PVC Piping	Gasket are attached between earth ring and flow tube. For 200mm or smaller size. (except 65,125mm)	A	A	A	A	N	/FRG
DHC use (for size 100 to 400mm)	Condensation proof for District Heating and Cooling use. Terminal box; urethane resin potting. Wired 30m signal cable at factory.	A	N	N	N	N	/DHC
Epoxy Coating	Coating is changed to epoxy coating.	A	A	A	N	A	/EPF
High Anti-corrosion Coating	Coating is changed to three-layer coating (Urethane coating on two-layer Epoxy coating)	A	A	A	N	N	/X2
Material Certificate (Note 2)	Reproduced material certificate for pipe, electrode, earth ring, mini-flange and flange (depends on spec.).	A	A	A	N	N	/M01
Bolt & Nut Assembly (Note 3)	Carbon steel bolts/nuts and chloroprene gaskets assembly for wafer type	A	A	A	N	N	/BCC
	Carbon steel bolts/nuts and non-asbestos PTFE-wrapped gaskets assembly for wafer type	A	A	A	N	N	/BCF
	Stainless steel bolts/nuts and chloroprene gaskets assembly for wafer type	A	A	A	N	N	/BSC
	Stainless steel bolts/nuts and non-asbestos PTFE-wrapped gaskets assembly for wafer type	A	A	A	N	N	/BSF
FM Approval CSA Certification (Note 4)	FM Explosion proof/Nonincendive, CSA Nonincendive For 200mm or smaller size.	N	N	A	N	N	/ND
CENELEC Certification (KEMA Approval)(Note 4)	CENELEC Explosion proof For 200mm or smaller size.	N	N	A	N	N	/CE
JIS Flameproof (Note 4)(Note 5)	JIS Flameproof type For 200mm or smaller size.	N	(Note 5)	N	N	N	/JF3
Flameproof Packing Adapter for JIS Flameproof(Note 5)	Two Flameproof Packing Adapters are attached.	N	(Note 5)	N	N	N	/G12
Silicon Rubber Gasket for sanitary type	In case of fluid temp. over 120 degC(248 degF); 160 degC (320 degF) max. (Not available with 65mm)	N	N	N	N	A	/SRG
GOST Certification	Calibration Certificate for GOST (only for products produced at YMF)	A	N	A	A	A	/GOS
C-Tick mark	AS/NZS2064 compliance Only for Australia or New Zealand	A	N	N	A	A	/CTK
Mirror Finished Ceramics	Mirror finishing on the inside of ceramic tube(Rmax.<= 1micro-meter)	A	A	A	N	N	/MRR
Oil-prohibited Use	Degreased cleansing treatment	A	A	A	N	N	/K1
Oil-prohibited Use with Dehydrating Treatment	Degreased cleansing treatment; Packaging with desiccant	A	A	A	N	N	/K5
Hydrostatics Test Certificate	Test pressure depends on process connection (Test duration 10minutes) Test result is full in NOTE of QIC.	A	A	A	A	N	/T01
Calibration Certificate	Level2:Declaration and Calibration Equipment List	A	A	A	A	A	/L2
	Level3:Declaration and Primary Standard List	A	A	A	A	A	/L3
	Level4:Declaration and YOKOGAWA Measuring Instruments Control System	A	A	A	A	A	/L4

Note1 No need to select because waterproof glands(union joint)are attached for submersible type as standard.  
 Note2 In case of requirement of EN10204 3.1B for Material Certificate, contact Yokogawa office.  
 Note3 It is available only for JIS 10K wafer, JIS 20K wafer or ANSI 150 wafer type, not available with 65, 125mm.  
 Note4 It is available only for size 2.5 to 200mm(0.1 to 8in.).  
 Note5 Select optional code /JF3 with /G12 in case of requirement of JIS Flameproof type.

T11.EPS

EXTERNAL DIMENSIONS

Unit : mm (Approx. inch)

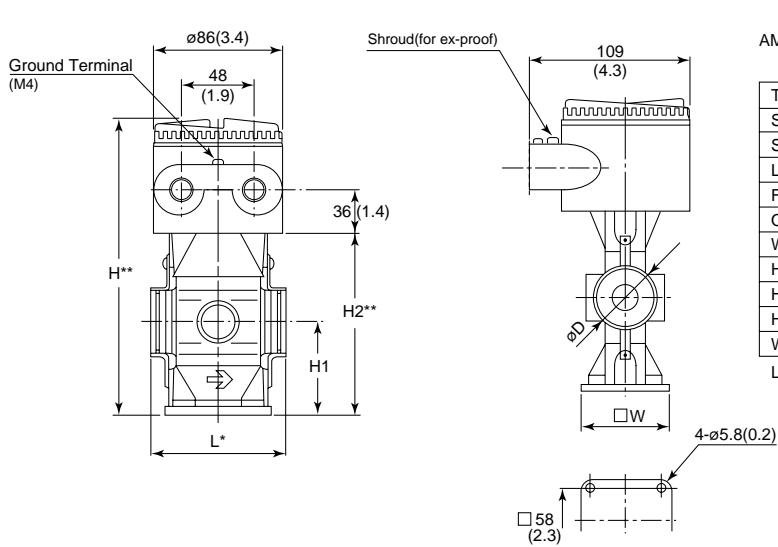

102	G	K	G	K
AM105	DC-A	B	AM115	DC-C
110	N	E	N	E
115				

Type	General (G), Ex-proof(C,N)			
Size code	102	105	110	115
Size	2.5(0.1)	5(0.2)	10(0.4)	15(0.5)
Lining code	A			A,C
Face-to-face	L	85(3.3)*		
Outer dia.	øD	44(1.7)		
Width	W	72(2.8)		
Height	H	214(8.4)**		
Height	H1	66(2.6)		
Height	H2	128(5.0)**		
Weight kg(lb)	2.4(5.3)			

Lining code A : PFA lining  
C : Ceramics pipe

\* The face-to-face length is longer by approx.22mm (0.89") for earth ring P.T. The face-to-face length is longer by approx.2mm (0.08")for PFA lining with optional code/FRG.

\*\* The height is shorter by 3mm (0.11") for ex-proof type.

SD1.eps

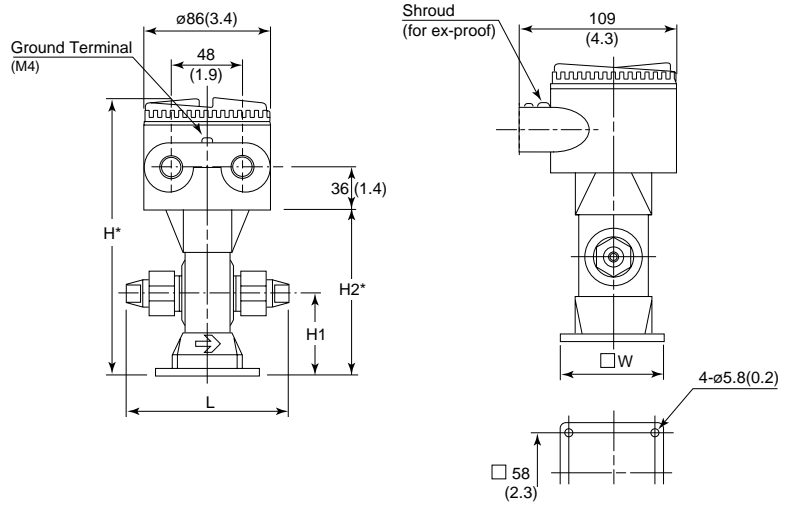

102 G  
AM105 DC-CU  
110 N

Process Connection

Size code	102	105	110
U1	Weld joint		
U2	R1/4	R3/8	
U3	1/4NPT	3/8NPT	

Type	General (G), Ex-proof(C,N)			
Size code	102	105	110	
Size	2.5(0.1)	5(0.2)	10(0.4)	
Lining code	C			
Process connection	U1	U2, U3	U1	U2, U3
Face-to-face	L	140(5.5)	130(5.1)	140(5.5)
Width	W	72(2.8)		
Height	H	202(8.0)*		
Height	H1	60(2.4)		
Height	H2	116(4.6)*		
Weight kg(lb)	2.4(5.3)			

Lining code C : Ceramics pipe  
\*The height is shorter by 3mm(0.12") for ex-proof type.

SD2c.eps

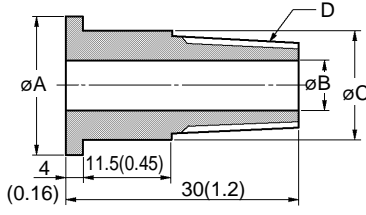

Size	A	B	C	D
2.5 (0.1)	22(0.87)	8(0.31)	18.5(0.73)	R1/4
5 (0.2)	22(0.87)	8(0.31)	18.5(0.73)	NPT1/4
10 (0.4)	25(0.98)	10(0.39)	22.5(0.89)	R3/8
	25(0.98)	10(0.39)	22.5(0.89)	NPT3/8

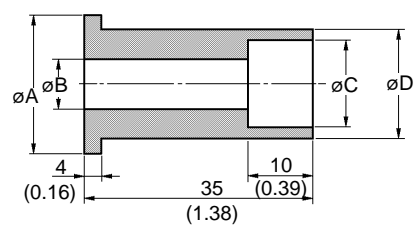

Size	A	B	C	D
2.5(0.1)	22(0.87)	8(0.31)	14.3(0.56)	18.5(0.73)
5(0.2)	22(0.87)	8(0.31)	14.3(0.56)	18.5(0.73)
10(0.4)	25(0.98)	10(0.39)	17.8(0.70)	22.5(0.89)

SD2.eps

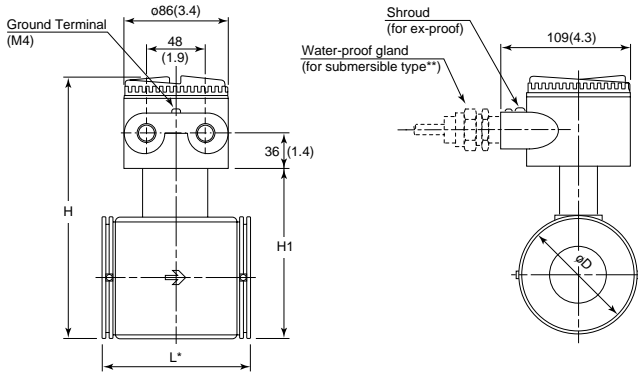

202 G K  
 204 W AB  
 205 D C UE  
 AM 206 N CH  
 208  
 210

Type	General(G), Submersible(W)							EX-proof(C,N)								
	202	204	205	206	208	210	208	210	202	204	205	208	210	208	210	
Size code	25(1)	40(1.5)	50(2)	65(2.5)	80(3)	100(4)	80(3)	100(4)	25(1)	40(1.5)	50(2)	80(3)	100(4)	80(3)	100(4)	
Size	A,U,C							A,C								
Lining code	A							C								
Face-to-face	L*	93(3.7)*	106(4.2)*	120(4.7)*	120(4.7)	160(6.3)*	180(7.1)*	160(6.3)*	180(7.1)*	93(3.7)*	106(4.2)*	120(4.7)*	160(6.3)*	180(7.1)*	160(6.3)*	180(7.1)*
Outer dia	D	68(2.7)	86(3.4)	99(3.9)	117(4.6)	129(5.1)	155(6.1)	129(5.1)	155(6.1)	68(2.7)	86(3.4)	99(3.9)	129(5.1)	155(6.1)	129(5.1)	155(6.1)
Height	H	197(7.8)	217(8.5)	230(9.1)	248(9.8)	270(10.6)	296(11.7)	260(10.2)	296(11.7)	195(7.7)	214(8.4)	228(9.0)	268(10.6)	296(11.7)	258(10.2)	294(11.6)
Height	H1	111(4.4)	131(5.2)	144(5.7)	162(6.4)	184(7.2)	210(8.3)	174(6.9)	210(8.3)	109(4.3)	128(5.0)	142(5.6)	182(7.2)	208(8.2)	172(6.8)	208(8.2)
Weight kg(lb)		2.3(5.5)	3.2(7.1)	4.2(9.3)	5.2(11.5)	7.3(16.1)	10.2(22.5)	6.9(15.2)	10(22.1)	2.3(5.5)	3.2(7.1)	4.2(9.3)	7.3(16.1)	10.2(22.5)	6.9(15.2)	10(22.1)

Lining code A : PFA lining

U : Polyurethane rubber lining

C : Ceramics pipe

- \* The face-to-face length is longer by approx.22mm(0.89") for earth ring P.T.
- \* The face-to-face length is longer by approx.2mm(0.08") for PFA or Polyurethane lining with optional code/FRG.
- \*\* Submersible flowtubes are provided with 30m(98ft) of signal and excitation cables, potted terminal box, and waterproof gland fittings. Please add 9.5kg(20.9lb) for submersible type.

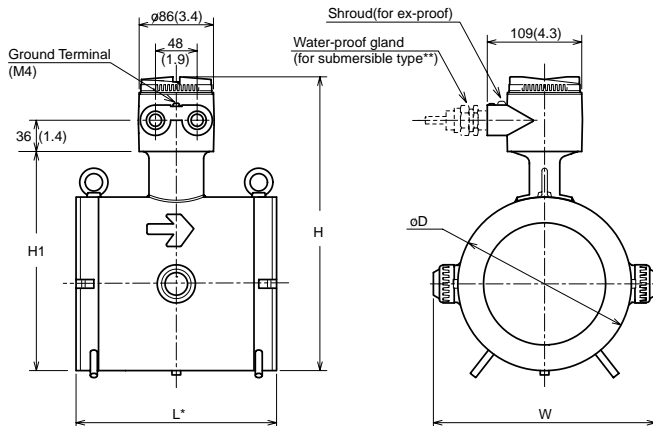

AM 212 G K  
 215 DW AB  
 220 N CH  
 C U E H

Type	General(G), Submersible(W)			Ex-proof(C, N)	
	212	215	220	215	220
Size code	125(5)	150(6)	200(8)	150(6)	200(8)
Size	A			A, U	
Lining code	A			C	
Face-to-face	L	230(9.1)	230(9.1)*	300(11.8)*	300(11.8)*
Outer dia.	D	175(6.9)	200(7.9)	250(9.8)	250(9.8)
Height	H	313(12.3)	339(13.3)	389(15.3)	336(13.2)
Height	H1	227(8.9)	253(9.9)	303(11.9)	250(10.1)
Width	W	230(9.1)	256(10.1)	307(12.1)	307(12.1)
Weight kg(lb)**		15.7(34.6)	17.9(39.4)	28.4(62.6)	20.9(46.1)

Lining code A : PFA lining  
 U : Polyurethane rubber lining

- \* The face-to-face length is longer by approx.30mm(1.2") for earth ring P.T.
- \* The face-to-face length is longer by approx.2mm(0.08") for optional code/FRG.
- \*\* Submersible flowtubes are provided with 30m (98ft) of signal and excitation cables, potted terminal box, and waterproof gland fittings. Please add 9.5kg(20.9lb) for submersible type.

SD4.eps

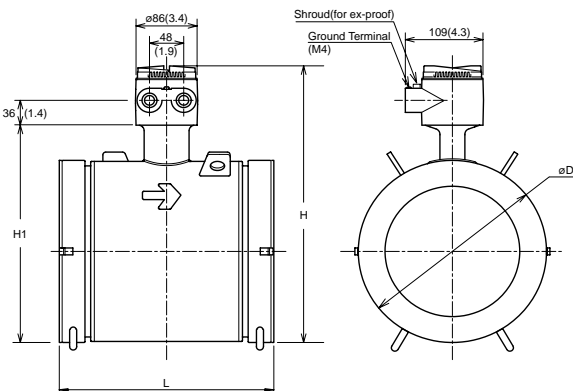

AM 215 G K  
 220 DN - C AB  
 C U E H

Type	General(G)		Ex-proof(C, N)	
	215	220	215	220
Size code	150(6)	200(8)	150(6)	200(8)
Size	C			
Lining code	C			
Face-to-face	L	232(9.2)	302(11.9)	302(11.9)
Outer dia	øD	214(8.5)	264(10.4)	264(10.4)
Height	H	352.5(13.9)	402.5(15.8)	350(13.8)
Height	H1	266.5(10.5)	316.5(12.5)	264(10.4)
Weight kg(lb)		21.6(47.7)	33.6(74.1)	24.6(54.2)

Lining code C : Ceramics pipe

SD7.eps

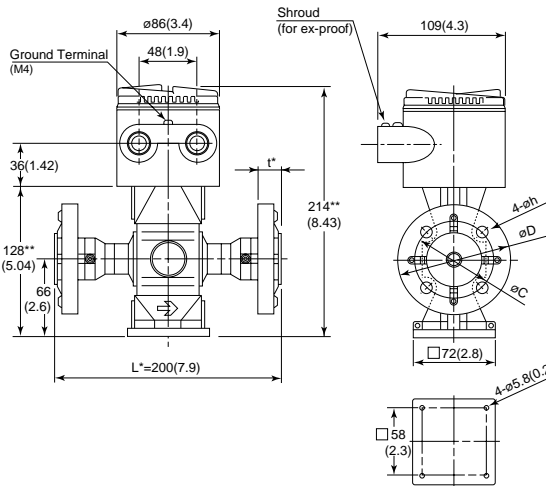

G J AM 115 DC - AA	
Type	General(G) Ex-proof(C,N)
Size code	115
Size	15(0.5)
Lining code	A
Process Connection	J1 J2 A1 A2 D2
Outer dia.	øD 95(3.7) 95(3.7) 89(3.5) 95(3.7) 95(3.7)
Thickness	t 19(0.7)-24(0.9)* 21(0.8)-26(1.0)* 18(0.7)-25(1.0)* 21(0.8)-28(1.1)* 20(0.8)-26(1.0)*
Pitch circle dia.	øC 70(2.8) 70(2.8) 61(2.4) 67(2.6) 65(2.6)
Hole dia.	øh 15(0.6) 15(0.6) 16(0.6) 16(0.6) 14(0.6)
Weight kg(lb)	4.0(8.8) 4.2(9.3) 3.8(8.4) 4.2(9.3) 4.2(9.3)

Process connection : J1 : JIS10K J2 : JIS20K A1 : ANSI 150 A2 : ANSI 300 D2 : DIN PN16  
Lining code A : PFA lining

- \* The face-to-face length is longer by approx.22mm (0.89") for earth ring P.T. The thickness(t) is longer by approx.11mm (0.43") for earth ring P.T. The face-to-face length is longer by approx.2mm (0.08") for optional code/FRG. The thickness(t) is longer by approx.1mm (0.04") for optional code/FRG.
- \*\* The height is shorter by 3mm (0.12") for ex-proof type.

SD11.eps

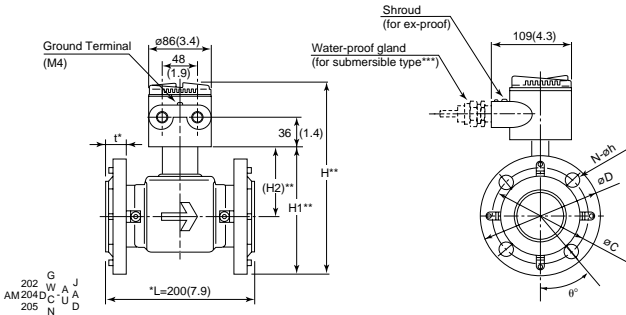

G J  
AM 204 DC - AA  
205 N

General(G), Submersible(W), Ex-proof(C,N)	
Type	202 204 205
Size code	25(1) 40(1.5) 50(2)
Size	
Lining code	A, U
Process Connection	J1 J2 A1 A2 D2 J1 J2 A1 A2 D2 J1 J2 A1 A2 D2
Height H	228(8.9) 217(8.5) 228(8.9) 221(8.7) 249(9.8) 249(9.8) 237(9.3) 251(9.9) 249(9.8) 259(10.2) 258(10.2) 251(10.1) 263(10.4) 263(10.4)**
Height H1	140(5.5) 140(5.5) 131(5.2) 138(5.4) 159(6.3) 159(6.3) 151(5.9) 158(6.2) 151(5.9) 172(6.8) 172(6.8) 171(6.7) 177(7.0) 177(7.0)**
Height H2	77(3.0)** 87.5(3.4)** 94.5(3.7)**
Outer dia. øD	125(4.9) 125(4.9) 108(4.3) 124(4.9) 115(4.5) 140(5.5) 140(5.5) 127(5.0) 155(6.1) 150(5.9) 155(6.1) 152(6.0) 165(6.5) 165(6.5)
Thickness t	21(0.8) 23(0.9) 21(0.8) 25(1) 22(0.9) 23(0.9) 25(1) 25(1) 28(1.1) 22(0.9) 23(0.9) 25(1) 25(1) 30(1.2) 24(0.9)
Pitch circle dia. øC	90(3.54) 90(3.54) 79(3.11) 89(3.50) 85(3.35) 105(4.13) 105(4.13) 99(3.90) 114(4.49) 110(4.33) 120(4.72) 120(4.72) 121(4.76) 127(5.00) 125(4.92)
Bolt hole pitch ø*	45 45 45 45 45 45 45 45 45 45 45 45 22.5 45 22.5 45
Hole dia. øh	19(0.75) 19(0.75) 16(0.63) 19(0.75) 14(0.55) 19(0.75) 19(0.75) 16(0.63) 22(0.87) 18(0.71) 19(0.75) 19(0.75) 19(0.75) 19(0.75) 19(0.75)
Number of holes N	4 4 4 4 4 4 4 4 4 4 4 4 8 4 8 4
Weight kg(lb)**	5.2(11.4) 5.5(12.1) 4.8(10.7) 5.8(12.8) 5.1(11.2) 7.4(16.3) 7.1(16.9) 7.0(15.4) 9.2(20.2) 8.0(18.5) 9.0(19.8) 9.1(20) 9.4(20.7) 10.8(23.8) 10.2(22.5)

Process connection : J1 : JIS10K J2 : JIS20K A1 : ANSI 150 A2 : ANSI 300 D2 : DIN PN16  
Lining code A : PFA Lining U : Polyurethane lining

- \* The face-to-face length is longer by approx.22mm (0.89") for earth ring P.T. The thickness(t) is longer by approx.11mm (0.43") for earth ring P.T. The face-to-face length is longer by approx.2mm (0.08") for optional code/FRG. The thickness(t) is longer by approx.1mm (0.04") for optional code/FRG.
- \*\* The height is shorter by 2.5mm (0.1") for ex-proof type.
- \*\* Submersible meters are provided with 30m (98ft) of signal and excitation cable, potted terminal box, and waterproof fittings. Please add 9.5kg (20.9lbs) in weight for submersible type.

SD12.eps

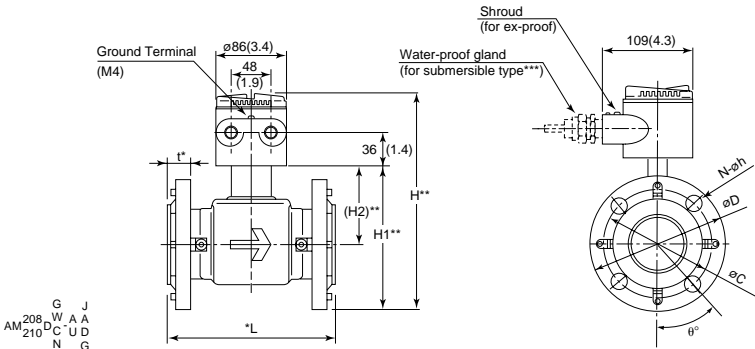

G J  
AM 208 DC - AA  
210 N G

General(G), Submersible(W), Ex-proof(C,N)	
Type	208 210
Size code	80(3) 100(4)
Size	
Lining code	A, U
Process Connection	J1 J2 A1 A2 D2 G1 J1 J2 A1 A2 D2 G1
Height H	288(11.3) 296(11.7) 291(11.4) 300(11.8) 296(11.7) 301(11.9) 324(12.8) 331(13.0) 333(13.1) 346(13.6) 328(13.0) 338(13.3)**
Height H1	202(8.0) 210(8.3) 205(8.1) 214(8.4) 210(8.3) 215(8.5) 238(9.4) 245(9.6) 247(9.7) 280(10.2) 243(9.6) 252(9.9)**
Height H2	109.5(4.3)** 132.5(5.2)**
Outer dia. øD	185(7.2) 200(7.9) 191(7.5) 210(8.3) 200(7.9) 211(8.3) 210(8.3) 225(8.9) 229(9.1) 254(10) 220(8.7) 238(9.4)
Thickness t	25(1) 29(1.1) 31(1.2) 36(1.4) 26(1) 25(1) 25(1) 31(1.2) 31(1.2) 39(1.5) 26(1) 25(1)
Pitch circle dia. øC	150(5.1) 160(6.3) 152(6.0) 168(6.6) 160(6.3) 168(6.6) 175(6.9) 185(7.3) 191(7.5) 200(7.9) 180(7.1) 195(7.7)
Bolt hole pitch ø*	22.5 22.5 45 22.5 22.5 45 22.5 22.5 22.5 22.5 22.5 19
Hole dia. øh	19(0.7) 23(0.8) 19(0.7) 22(0.8) 18(0.7) 19(0.7) 19(0.7) 23(0.9) 19(0.7) 22(0.9) 18(0.7) 22.5(0.8)
Number of holes N	8 8 4 8 8 4 8 8 8 8 8 4
Face-to-face L	200(7.9)* 250(9.8)*
Weight kg(lb)**	13(28.6) 15(33.0) 15.3(33.7) 18.3(40.3) 15(33.1) 15.5(34.2) 21.0(46.3) 24.2(53.4) 25.0(55.1) 32.4(71.4) 22.7(50.1) 24.1(53.1)

Process connection : J1 : JIS10K J2 : JIS20K A1 : ANSI 150 A2 : ANSI 300 D2 : DIN PN16 G1 : JIS F12  
Lining code A : PFA Lining U : Polyurethane lining

- \* The face-to-face length is longer by approx.22mm (0.89") for earth ring P.T. The thickness(t) is longer by approx.11mm (0.43") for earth ring P.T. The face-to-face length is longer by approx.2mm (0.08") for optional code/FRG. The thickness(t) is longer by approx.1mm (0.04") for optional code/FRG.
- \*\* The height is shorter by 2.5mm (0.1") for ex-proof type.
- \*\* Submersible meters are provided with 30m (98ft) of signal and excitation cable, potted terminal box, and waterproof fittings. Please add 9.5kg (20.9lbs) in weight for submersible type.

SD13.eps

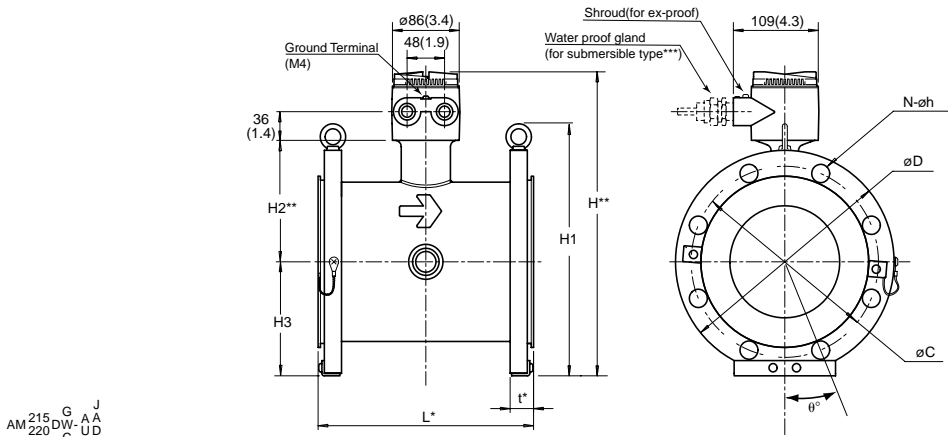

AM 215 G J  
220 DW- A A  
C U D  
N G

Type	General(G), Submersible(W), Ex-proof(C, N)															
Size code	215								220							
Size	150(6)								200(8)							
Lining code	A, U															
Process connection	J1	G1	A1	J2	A2	D1	D2	J1	G1	A1	J2	A2	D1	D2		
Face-to-face	270(10.6)*								340(13.4)*							
Outer dia.	øD	280(11)	290(11.4)	279(11.0)	305(12)	318(12.5)	285(11.2)	330(13)	342(13.5)	343(13.5)	350(13.8)	381(15.0)	340(13.4)	340(13.4)		
Height	H	382(15)	387(15.2)	381(15.0)	394(15.5)	401(15.8)	384(15.1)	432(17.0)	438(17.2)	438(17.3)	442(17.4)	457(18.0)	437(17.2)	437(17.2)		
Height	H1	317(12.5)	327(12.9)	316(12.4)	342(13.4)	354(13.9)	322(12.7)	367(14.4)	379(14.9)	379(14.9)	387(15.2)	418(16.4)	377(14.8)	377(14.8)		
	H2	152.5(6.0)								177.5(7.0)						
Pitch circle dia.	øC	143(5.6)	148(5.8)	143(5.6)	156(6.1)	162(6.4)	148(5.7)	168(6.6)	174(6.9)	175(6.9)	178(7.0)	194(7.6)	173(6.8)	173(6.8)		
	øC	240(9.4)	247(9.7)	241(9.5)	260(10.2)	270(10.6)	240(9.4)	290(11.4)	299(11.8)	298(11.7)	305(12)	330(10.6)	295(11.6)	295(11.6)		
Bolt hole pitch	θ°	22.5	30	22.5	15	15	22.5	15	22.5	22.5	15	15	22.5	15		
Number of holes	N	8	6	8	12	12	8	8	12	8	8	12	8	12		
	øh	23(0.9)	19(0.7)	23(0.9)	25(1)	22(0.9)	22(0.9)	23(0.9)	19(0.9)	23(0.9)	25(1.0)	25(1.0)	22(0.9)	22(0.9)		
Thickness(A)	t	30(1.2)	30(1.2)	33(1.3)	36(1.4)	44.5(1.8)	30(1.2)	30(1.2)	32(1.3)	36(1.4)	38(1.5)	49.1(1.9)	32(1.3)	32(1.3)		
Thickness(U)	t	31(1.2)	31(1.2)	34(1.4)	37(1.5)	45.5(1.8)	31(1.2)	31(1.2)	33(1.3)	37(1.5)	39(1.5)	50.1(2.0)	33(1.3)	33(1.3)		
Weight(General) kg(lb)		29(63.9)	31(68.3)	31(68.3)	37(81.6)	48(105.8)	30(66.1)	31(68.3)	41(90.2)	46(101.2)	49(107.8)	52(114.4)	73(160.6)	45(99.2)	46(101.2)	
Weight(Submersible) kg(lb)		38.5(84.9)	40.5(89.3)	40.5(89.3)	46.5(102.5)	57.5(126.8)	39.5(87.1)	40.5(89.3)	50.5(111.4)	55.5(122.4)	58.5(129.0)	61.5(135.6)	82.5(181.9)	54.5(120.2)	55.5(122.4)	
Weight(Ex-proof) kg(lb)		32(70.6)	34(75.0)	34(75.0)	40(88.2)	51(112.5)	33(72.8)	34(75.0)	46(101.4)	51(112.5)	54(119.1)	57(125.7)	78(172.0)	50(110.3)	51(112.5)	

\* The face-to-face length is longer by approx.28mm (1.1") for earth ring P.T.  
 The thickness(t) is longer by approx.14mm (0.55") for earth ring P.T.  
 The face-to-face length is longer by approx.2mm (0.08") for optional code/FRG.  
 The thickness(t) is longer by approx.1mm (0.04") for optional code/FRG.  
 \*\* The height is shorter by 2.5mm (0.1") for ex-proof type.  
 \*\*\* Submersible meters are provided with 30m (98ft) of signal and excitation cable, potted terminal box, and waterproof gland fittings.

Process connection : J1 : JIS10K J2 : JIS20K A1 : ANSI 150 A2 : ANSI 300  
 D1 : DIN PN10 D2 : DIN PN16 G : JIS F12  
 Lining code A : PFA Lining  
 U : Polyurethane lining

JIS Flameproof Packing Adapter /G12

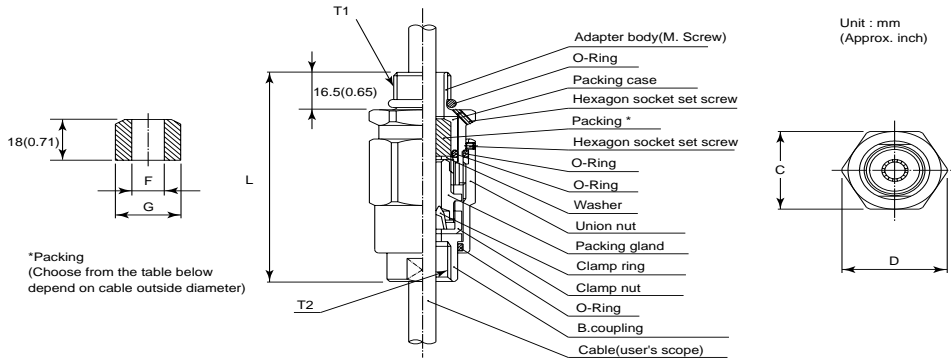

\*Packing  
 (Choose from the table below  
 depend on cable outside diameter)

Dimension					Cable outer diameter	Packing diameter		Identification mark	Weight kg (lb)
T1	T2	C	D	L		F	G		
G 1/2	G 1/2	35 (1.38)	39 (1.54)	94.5 (3.72)	ø8.0 to ø10.0 (0.31 to 0.39)	ø10.0(0.39)	ø20.0	16 8-10	0.26
					ø10.0 to ø12.0 (0.39 to 0.47)	ø12.0(0.47)	(0.79)	16 10-12	(0.57)

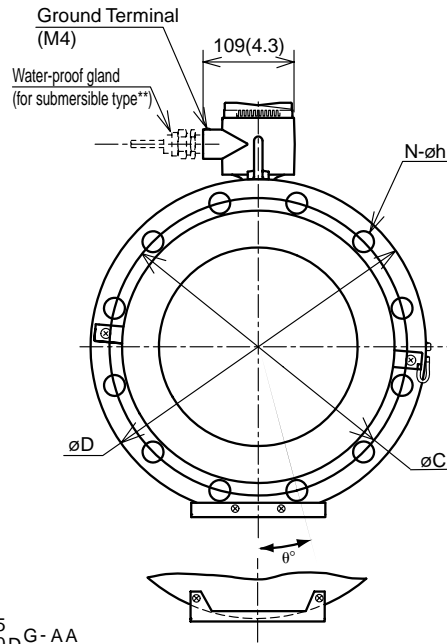
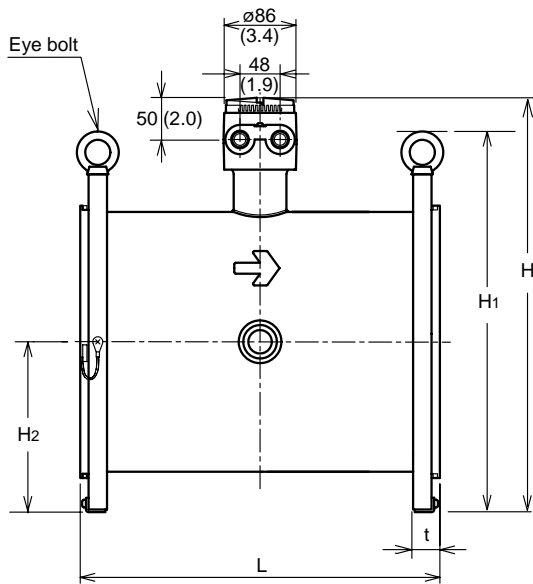

325  
AM330<sub>D</sub><sub>W</sub> G-AA  
335 UD  
340

for AM330, AM335, AM340

325  
AM330<sub>D</sub><sub>W</sub> G-AJ  
335 UG  
340

	Type		General(G), Submersible(W)				
	Size code		325	330	335	340	
	Size		250	300	350	400	
Lining code			A, U				
	Face-to-face	L	430(16.9)	500(19.7)	550(21.7)	600(23.6)	
	Eye bolt hole dia.	e	30(1.2)	30(1.2)	35(1.4)	35(1.4)	
Height	H	497(19.6)	544(21.4)	587(23.1)	650(25.6)		
	H1	454(17.9)	499(19.7)	553(21.8)	623(24.5)		
	H2	203(7.9)	226(9.0)	248(9.8)	283(11.1)		
	Outer dia.	øD	400(15.8)	445(17.5)	490(19.3)	560(22.0)	
	Pitch circle dia.	øC	355(14.0)	400(15.8)	445(17.5)	510(20.1)	
	Number of holes	N	12	16	16	16	
	Bolt hole pitch	ø°	15	11.25	11.25	11.25	
	Hole dia.	øh	25(1.0)	25(1.0)	25(1.0)	27(1.1)	
	Thickness(A)	t	32(1.3)	34(1.3)	36(1.4)	38(1.5)	
	Thickness(U)	t	33(1.3)	35(1.4)	37(1.4)	39(1.5)	
	Weight kg(lb)**		64(141.1)	81(178.6)	94(207.2)	122(269.0)	
JIS 20K	Height	H	512(20.2)	561(22.1)	-	-	
		H1	484(19.1)	534(21.0)	-	-	
		H2	218(8.6)	243(9.6)	-	-	
		Outer dia.	øD	430(16.9)	480(18.9)	-	-
		Pitch circle dia.	øC	380(15.0)	430(16.9)	-	-
		Number of holes	N	12	16	-	-
		Bolt hole pitch	ø°	15	11.25	-	-
	Hole dia.	øh	27(1.1)	27(1.1)	-	-	
	Thickness(A)	t	42(1.7)	44(1.7)	-	-	
	Thickness(U)	t	43(1.7)	45(1.8)	-	-	
	Weight kg(lb)**		67(147.7)	85(187.4)	-	-	
JIS F12	Height	H	502(19.8)	553(21.8)	607(23.9)	661(26.0)	
		H1	464(18.3)	518(20.4)	593(23.4)	645(25.4)	
		H2	208(8.2)	235(9.3)	268(10.6)	294(11.6)	
		Outer dia.	øD	410(16.1)	464(18.3)	530(20.9)	582(22.9)
		Pitch circle dia.	øC	360(14.2)	414(16.3)	472(18.6)	524(20.6)
		Number of holes	N	8	10	10	12
		Bolt hole pitch	ø°	22.5	18	18	15
	Hole dia.	øh	23(0.9)	23(0.9)	25(1.0)	25(1.0)	
	Thickness(A)	t	32(1.3)	34(1.3)	36(1.4)	36(1.4)	
	Thickness(U)	t	33(1.3)	35(1.4)	37(1.5)	37(1.5)	
	Weight kg(lb)**		64(141.1)	81(178.6)	94(207.2)	122(269.0)	

Lining code A : PFA lining  
U : Polyuretane lining

\*\* Submersible meters are provided with 30m (98ft) of signal and excitation cable, potted terminal box, and waterproof fittings.  
Please add 9.5kg (20.9lbs) in weight for submersible type.

Type	General(G), Submersible(W)						
	325	330	335	340			
Size code	250	300	350	400			
Size	250	300	350	400			
Lining code	A, U						
Face-to-face	L	430(16.9)	500(19.7)	550(21.7)	600(23.6)		
Eye bolt hole dia.	e	30(1.2)	30(1.2)	35(1.4)	35(1.4)		
Height	H	500(19.7)	563(22.2)	609(24.0)	668(26.3)		
	H1	461(18.1)	537(21.1)	597(23.5)	660(26.0)		
	H2	206(8.1)	245(9.7)	270(10.6)	302(11.9)		
	Outer dia.	øD	406(16.0)	483(19.0)	533(21.0)	597(23.5)	
	Pitch circle dia.	øC	362(14.3)	432(17.0)	476(18.7)	540(21.3)	
	Bolt hole pitch	ø°	15	15	15	11.25	
	Number of holes	N	12	12	12	16	
	Hole dia.	øh	26(1.0)	26(1.0)	29(1.1)	29(1.1)	
	Thickness(A)	t	38(1.5)	40(1.6)	45(1.8)	47(1.9)	
	Thickness(U)	t	39(1.5)	41(1.6)	46(1.8)	48(1.9)	
	Weight kg(lb)**		70(154.3)	90(198.4)	110(242.5)	145(319.7)	
ANSI 150	Height	H	519(20.4)	582(22.9)	-	-	
		H1	499(19.7)	575(22.6)	-	-	
		H2	225(8.9)	264(10.4)	-	-	
		Outer dia.	øD	445(17.5)	521(20.5)	-	-
		Pitch circle dia.	øC	387(15.2)	451(17.8)	-	-
		Number of holes	N	16	16	-	-
		Bolt hole pitch	ø°	11.25	11.25	-	-
	Hole dia.	øh	29(1.1)	32(12.6)	-	-	
	Thickness(A)	t	56(2.3)	59(2.3)	-	-	
	Thickness(U)	t	57(2.2)	60(2.4)	-	-	
	Weight kg(lb)**		75(165.4)	98(216.1)	-	-	
ANSI 300	Height	H	495(19.5)	544(21.4)	595(23.4)	652(25.7)	
		H1	449(17.7)	499(19.7)	568(22.4)	628(24.7)	
		H2	201(7.9)	226(9.0)	256(10.0)	286(11.3)	
		Outer dia.	øD	395(15.6)	445(17.5)	505(20.0)	565(22.2)
		Pitch circle dia.	øC	350(13.8)	400(15.8)	460(18.1)	515(20.3)
		Number of holes	N	12	12	16	16
		Bolt hole pitch	ø°	15	15	11.25	11.25
	Hole dia.	øh	22(0.9)	22(0.9)	22(0.9)	26(1.0)	
	Thickness(A)	t	34(1.3)	34(1.3)	36(1.4)	36(1.4)	
	Thickness(U)	t	35(1.4)	35(1.4)	37(1.5)	37(1.5)	
	Weight kg(lb)**		64(141.1)	81(178.6)	94(207.2)	122(269.0)	
DIN PN10	Height	H	500(19.7)	551(21.7)	-	-	
		H1	459(18.1)	514(20.2)	-	-	
		H2	206(8.1)	233(9.2)	-	-	
		Outer dia.	øD	405(15.9)	460(18.1)	-	-
		Pitch circle dia.	øC	355(14.0)	410(16.1)	-	-
		Number of holes	N	12	12	-	-
		Bolt hole pitch	ø°	15	15	-	-
	Hole dia.	øh	22(0.9)	22(0.9)	-	-	
	Thickness(A)	t	34(1.3)	36(1.4)	-	-	
	Thickness(U)	t	35(1.4)	37(1.5)	-	-	
	Weight kg(lb)**		65(143.3)	82(180.8)	-	-	
DIN PN16	Height	H	500(19.7)	551(21.7)	-	-	
		H1	459(18.1)	514(20.2)	-	-	
		H2	206(8.1)	233(9.2)	-	-	
		Outer dia.	øD	405(15.9)	460(18.1)	-	-
		Pitch circle dia.	øC	355(14.0)	410(16.1)	-	-
		Number of holes	N	12	12	-	-
		Bolt hole pitch	ø°	15	15	-	-
	Hole dia.	øh	22(0.9)	22(0.9)	-	-	
	Thickness(A)	t	34(1.3)	36(1.4)	-	-	
	Thickness(U)	t	35(1.4)	37(1.5)	-	-	
	Weight kg(lb)**		65(143.3)	82(180.8)	-	-	

Lining code A : PFA lining  
U : Polyuretane lining

\*\* Submersible meters are provided with 30m (98ft) of signal and excitation cable, potted terminal box, and waterproof fittings.  
Please add 9.5kg (20.9lbs) in weight for submersible type.

SD16.eps

AM405/406/407/408/409/410

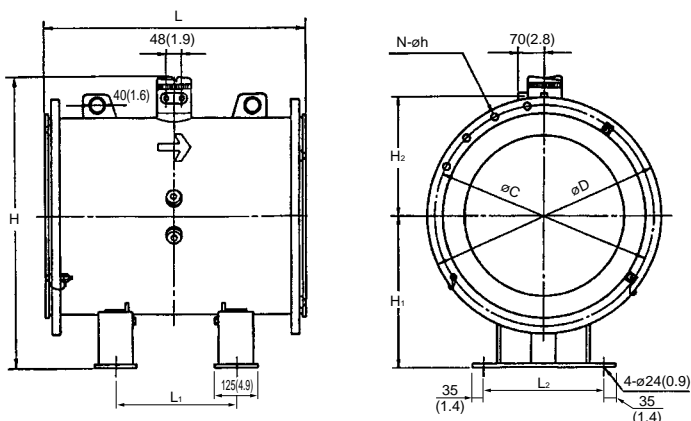

Cables are wired with water-proof glands for submersible type at the factory.

Model	AM405	AM406	AM407	AM408	AM409	AM410
Size	500(20)	600(24)	700(28)	800(32)	900(36)	1000(40)
Face-to-face	L	750(29.5)	800(31.5)	900(35.4)	1050(41.3)	1300(51.2)
Height	H	450(17.7)	500(19.7)	550(21.7)	600(23.6)	700(27.6)
Height	H1	840(33.1)	939(37.0)	1043(41.1)	1148(45.2)	1247(49.1)
Height	H2	334(13.1)	383(15.1)	437(17.2)	492(19.4)	541(21.3)
Outer dia.	øD	675(26.6)	795(31.3)	905(35.6)	1020(40.2)	1120(44.1)
Pitch circle dia.	øC	620(24.4)	730(28.7)	840(33.1)	950(37.4)	1050(41.3)
Number of holes	N	20	24	24	28	28
Hole dia.	øh	27(1.1)	33(1.3)	33(1.3)	33(1.3)	38(1.5)
Thickness	t	30(1.2)	32(1.3)	34(1.4)	36(1.4)	40(1.6)
Weight*kg(lb)*		260(57.3)	400(88.2)	510(112.5)	680(150.0)	870(191.9)
Height	H	840(33.1)	939(37.0)	-	-	-
Height	H1	334(13.1)	383(15.1)	-	-	-
Outer dia.	øD	700(27.6)	815(32.1)	-	-	-
Pitch circle dia.	øC	635(25.0)	750(29.5)	-	-	-
Number of holes	N	20	20	-	-	-
Hole dia.	øh	32(1.3)	35(1.4)	-	-	-
Thickness	t	43(1.7)	48(1.9)	-	-	-
Weight*kg(lb)*		360(79.4)	450(99.2)	-	-	-
Height	H	840(33.4)	951(37.4)	1050(41.3)	1153(45.4)	1259(49.6)
Height	H1	343(13.5)	395(15.6)	444(17.5)	497(19.6)	553(21.8)
Outer dia.	øD	708(27.8)	810(31.9)	928(36.5)	1034(40.7)	1156(45.5)
Pitch circle dia.	øC	639(25.2)	743(29.3)	854(33.6)	960(37.8)	1073(42.2)
Number of holes	N	12	16	16	20	20
Hole dia.	øh	27(1.1)	27(1.1)	33(1.3)	33(1.3)	33(1.3)
Thickness	t	30(1.2)	32(1.3)	35(1.4)	37(1.5)	39(1.5)
Weight*kg(lb)*		245(54.0)	300(66.2)	450(99.2)	620(136.7)	770(169.8)
Support interval	L1	350(13.8)	400(15.8)	450(17.7)	550(21.7)	700(27.6)
Mounting bolt interval	L2	350(13.8)	400(15.8)	500(19.7)	550(21.7)	650(25.6)

\*: The weight is added 9.5kg(20.9lb) for submersible type.

AM511/512/513

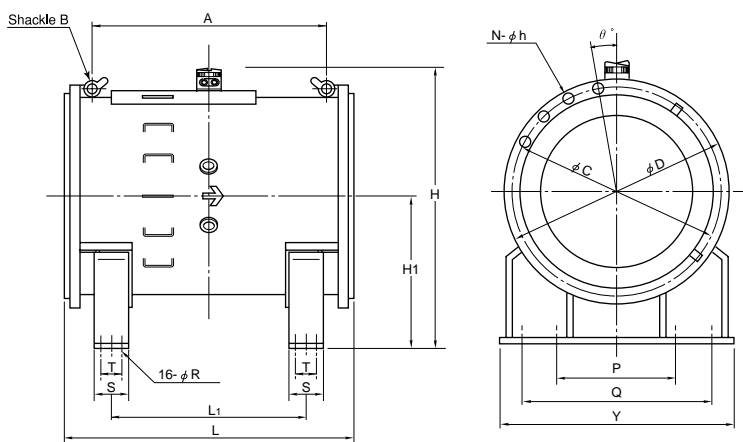

Model	AM511D	AM512D	AM513D
Size	1100(44)	1200(48)	1350(54)
Face-to-face	L	1650(65)	2025(79.7)
Height	H1	950(37.4)	1000(39.4)
Height	H	1698(66.9)	1803(71.0)
Shackle	Interval	A	1325(52.2)
	Size	B	SB24
Support	Width	S	200(7.9)
	Length	Y	1280(50.4)
Mounting Bolt	Interval	L1	1211(47.7)
		P	720(28.3)
		Q	1100(43.3)
		T	130(5.1)
JIS F12	Hole dia.	R	19(0.75)
	Outer dia.	D	1366(53.8)
	Pitch circle dia.	C	1283(50.5)
	Bolt hole pitch	θ°	7.5
	Number of holes	N	24
	Hole dia.	h	33(1.3)
	Thickness	t	78(3.4)
Weight*kg(lb)		1650(3638)	

\*Submersible flowtubes are provided with 30m (98ft) of signal and excitation cables, potted terminal box, and waterproof gland fittings. Please add 9.5kg(20.9lb) for submersible type.

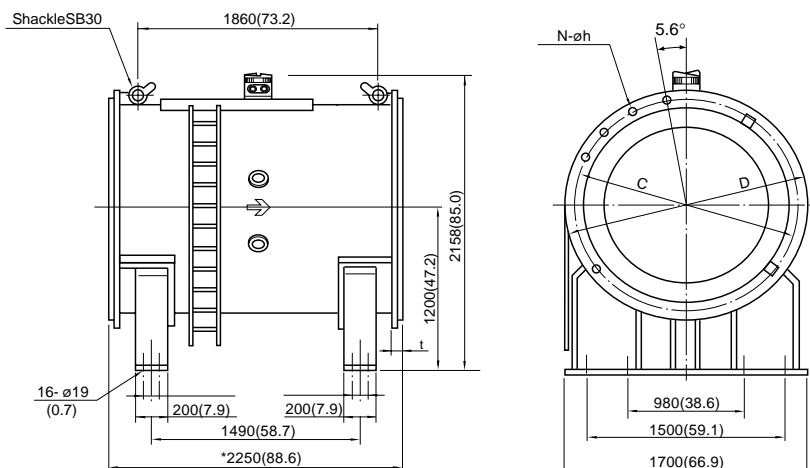

AM515

Model	AM515
Size	1500(60)
Outer dia.	D
Pitch circle dia.	C
Number of holes	N
Hole dia.	h
Thickness	t
Weight*kg(lb)	3150(6946)

\*Submersible flowtubes are provided with 30m (98ft) signal and excitation cables, potted terminal box, and waterproof gland fittings. Please add 9.5kg(20.9lb) for submersible type.

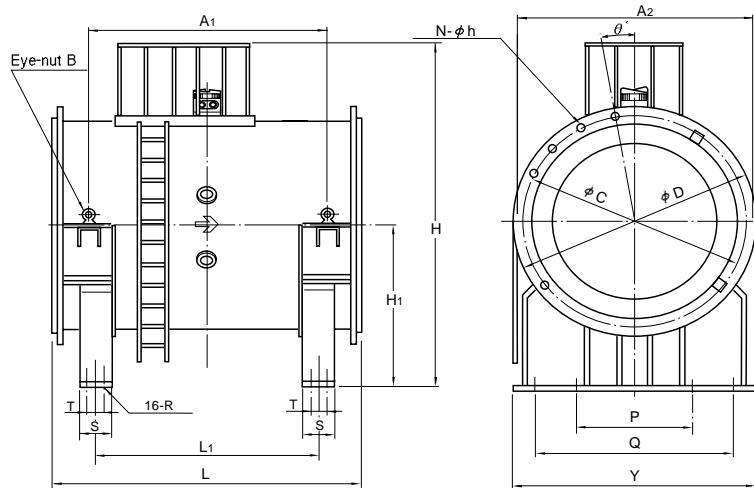

**AM516/518/520/522/524/526**

Model	AM516	AM518	AM520	AM522	AM524	AM526
Size	1600(64)	1800(72)	2000(80)	2200(88)	2400(96)	2600(104)
Face-to-face	L	2400(94.5)	2610(102.8)	2800(110.2)	2970(117.0)	3120(122.8)
Height	H1	1280(50.4)	1350(53.2)	1450(57.1)	1550(61.0)	1700(66.9)
Height	H	2971(117.0)	3143(123.7)	3346(131.7)	3553(139.9)	3811(150.0)
Eye nut	Interval1	A1	1834(72.2)	2022(79.6)	2191(85.7)	2325(86.3)
	Interval2	A2	1872(73.7)	2078(81.8)	2300(90.6)	2520(99.2)
Eye nut	Size	B	M48	M48	M48	M64
Support	Width	S	250(9.8)	250(9.8)	250(9.8)	300(11.8)
	Length	Y	1850(72.8)	2000(78.7)	2220(87.4)	2420(95.3)
	Interval	L1	1698(66.9)	1864(73.4)	2010(79.1)	2172(85.5)
Mounting bolt	Interval	P	1080(42.5)	1180(46.5)	1300(51.2)	1430(56.3)
	Interval	Q	1650(65.0)	1800(70.9)	2000(78.7)	2200(86.6)
	Interval	T	170(6.7)	170(6.7)	170(6.7)	200(7.9)
	Hole dia.	R	22(0.87)	22(0.87)	22(0.87)	22(0.87)
JIS G5527 7.5K Flange	Outer dia.	D	1915(75.4)	2115(83.3)	2325(91.5)	2550(100.4)
	Pitch circle dia.	C	1820(71.7)	2020(79.5)	2230(87.8)	2440(96.1)
	Bolt hole pitch	$\theta^\circ$	5	4.1	3.75	3.5
	Number of holes	N	36	44	48	52
	Hole dia.	h	39(1.5)	39(1.5)	46(1.8)	46(1.8)
	Thickness	t	88(3.5)	90(3.5)	92(3.6)	95(3.7)
	Weight* kg(lb)		3650(8048)	5270(11620)	6500(14333)	8400(18522)

\*Submersible flowtubes are provided with 30m (98ft) of signal and excitation cables, potted terminal box, and waterproof gland fittings. Please add 9.5kg(20.9lb) for submersible type.

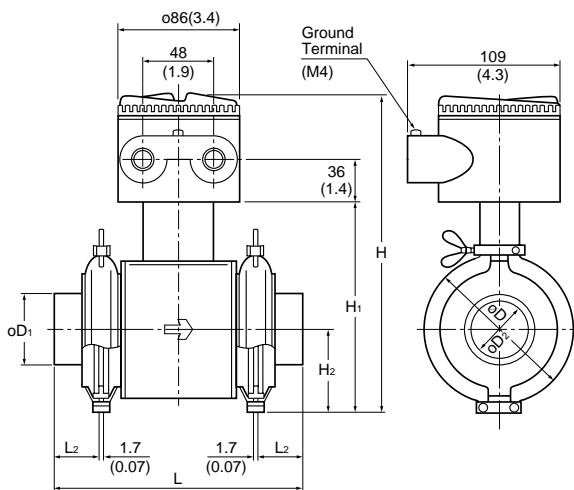

- 202
- 204
- 205
- AM206 DH
- 208
- 210

Type	Sanitary(H)					
	202	204	205	206	208	210
Size code	202	204	205	206	208	210
Size	25(1)	40(1.5)	50(2)	65(2.5)	80(3)	100(4)
Lining	PFA lining					
Face-to-face	L	176(6.9)	186(7.3)	206(8.1)	206(8.1)	272(10.7)
Ferrule length	L2	43(1.7)	41(1.6)	44(1.7)	44(1.7)	44(1.7)
Ferrule outer dia.	D1	25(1.0)	38(1.5)	51(2.0)	64(2.5)	102(4.0)
Ferrule inner dia.	D2	23(0.9)	36(1.4)	48(1.9)	60(2.4)	72(2.8)
Clamp outer dia.	D	74(2.9)	90(3.5)	103(4.1)	122(4.8)	171(6.7)
Height	H	212(8.3)	235(9.3)	248(9.8)	260(10.2)	329(13.0)
Height	H1	126(5.0)	149(5.8)	162(6.4)	174(6.9)	243(9.6)
Height	H2	49(1.7)	61(2.4)	67(2.6)	70(2.8)	111(4.4)
Weight kg(lb)		3.5(7.7)	4.6(10.1)	6.0(13.2)	7.6(16.8)	15.4(33.8)

SD21.EPS

# 6. HAZARDOUS DUTY TYPE INSTRUMENT

In this section, further requirements and differences for explosion proof type instrument are described. For explosion proof type instrument, the description in this chapter is prior to other description in this Instruction Manual.



## NOTE

The terminal box cover is locked by special screw. In case of opening the terminal box cover, please use the Hexagonal Wrench attached.



## CAUTION

Be sure to lock the cover with the special screw using the Hexagonal Wrench attached after tightening the cover.

## 6.1 FM

### (1) Technical Data

- Explosionproof for Class I Division 1 Groups A, B, C & D. Dust-ignitionproof for Class II/III Division 1 Groups E, F & G. Intrinsically safe (electrode) for Class I Division 1 Groups A, B, C & D  
Electrode circuit  $V_{max}$  : 250V ac/dc  
Temp. Class. T6  
Enclosure : NEMA 4X
- Nonincendive for Class I, Division 2, Groups A, B, C & D ; Suitable for Class II, Division 2, Groups F & G ; Class III, Division 1 and 2  
Intrinsically safe (electrode) for Class I Division 1 Groups A, B, C & D  
Electrode Circuit  $V_{max}$  : 250V ac/dc  
Excitation Circuit : 130Vp 72/75Hz  
Temp. Code : T5  
Enclosure : NEMA 4X

### (2) Installation



## WARNING

- All wiring shall comply with national electrical code ANSI/NFPA 70 and local electrical code.
- In hazardous locations, wiring to be in conduit as shown in the figure.

### (3) Operation



## WARNING

- Open circuit before opening the covers and seal all conduits with in 18 inches in hazardous locations.
- Take care not to generate mechanical spark when access to the instrument and peripheral devices in hazardous locations.

### (4) Maintenance and Repair



## WARNING

The instrument modification or parts replacement by other than authorized representative of Yokogawa Electric Corporation is prohibited and will void the approval of Factory Mutual Research Corporation.

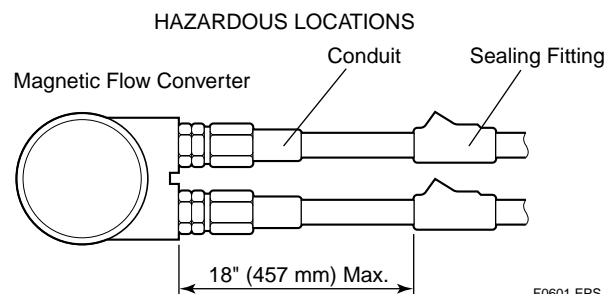

## 6.2 CSA

### (1) Technical Data

- Nonincendive for Class I, Division 2, Groups A, B, C & D ; Suitable for Class II, Division 2, Groups E, F and G ; Class III, Division 2  
Intrinsically safe (electrode) for Class I Division 1 Groups A, B, C & D  
Electrode Circuit Vmax: 250V ac/dc  
Excitation Circuit: 130Vp 72/75Hz, 11VAmx  
Temp. Code    T5    T4    T3  
Process Temp    85    120    150°C  
Enclosure: Type 4

### (2) Installation



#### WARNING

All wiring shall comply with Canadian Electrical Code Part I and Local Electrical Codes.

### (3) Operation



#### WARNING

**CAUTION : OPEN CIRCUIT BEFORE REMOVING COVER.**

OUVRIER LE CIRCUIT AVANT  
D'ENLEVER LE COUVERCLE.

Take care not to generate mechanical spark when access to the instrument and peripheral devices in hazardous location.

### (4) Maintenance and Repair



#### WARNING

The instrument modification or parts replacement by other than authorized representative of YOKOGAWA Electric Corporation or YOKOGAWA Corporation of AMERICA is prohibited and will void Canadian Standards Explosionproof Certification.

## 6.3 CENELEC (KEMA)



#### WARNING

Only trained persons use this instrument in industrial locations.

### (1) Technical Data

- CENELEC (KEMA) : KEMA No. Ex-94. C. 8524  
EEx dm[ia]IIC T6...T3  
Electrode circuit Vmax : 250V ac/dc  
Excitation Circuit : 130Vp 72/75Hz  
Temp. Class    T6    T5    T4    T3  
Process Temp    70    85    120    150°C

### (2) Installation



#### WARNING

- All wiring shall comply with local installation requirements and local electrical code.
- In hazardous locations, the cable entry devices shall be of a certified flameproof type, suitable for the conditions of use and correctly installed.

### (3) Operation



#### WARNING

- Open circuit before opening the covers.
- Take care not to generate mechanical spark when access to the instrument and peripheral devices in hazardous locations.

### (4) Maintenance and Repair



#### WARNING

The instrument modification or parts replacement by other than authorized representative of Yokogawa Electric Corporation is prohibited and will void the certification.

## 6.4 JIS



### WARNING

---

Care should be taken to install, wiring, piping to keep safety. This instrument is restricted to maintenance and repair. Please read "INSTALLATION AND OPERATING PRECAUTIONS FOR JIS FLAMEPROOF EQUIPMENT" in the end of this manual.

---

#### (1) Technical Data

- Construction : Exde [ia] II CT4X
  - : Terminal box ; Explosion proof
  - Flow Tube ; Increased Safety
  - Signal Circuit ; Intrinsically Safety (ia)
  - Um=250 V AC 50/60 Hz, 250 V DC,
  - Uo=250 V\*, Io=3.37 mA\*, Po=0.211 W
  - \* Uo and Io are rms value.
- : Ignition and Explosion Class of gas or vapour ; II CT4X
- Ambient Temperature : -10 to 60°C
- Fluid Temperature : 120°C or less
- Current Signal Circuit Allowable Voltage :
  - 250V AC/DC
- Grounding : 10 Ω or less



### WARNING

---

In case the ambient temperature exceeds 50°C, use heat-resistant cables with maximum allowable temperature of 70°C or above.

---

#### (2) Wiring

Flameproof packing adapter is attached to electrical connection.



### WARNING

---

Please use G12 (option) flameproof packing adapter attached.

---

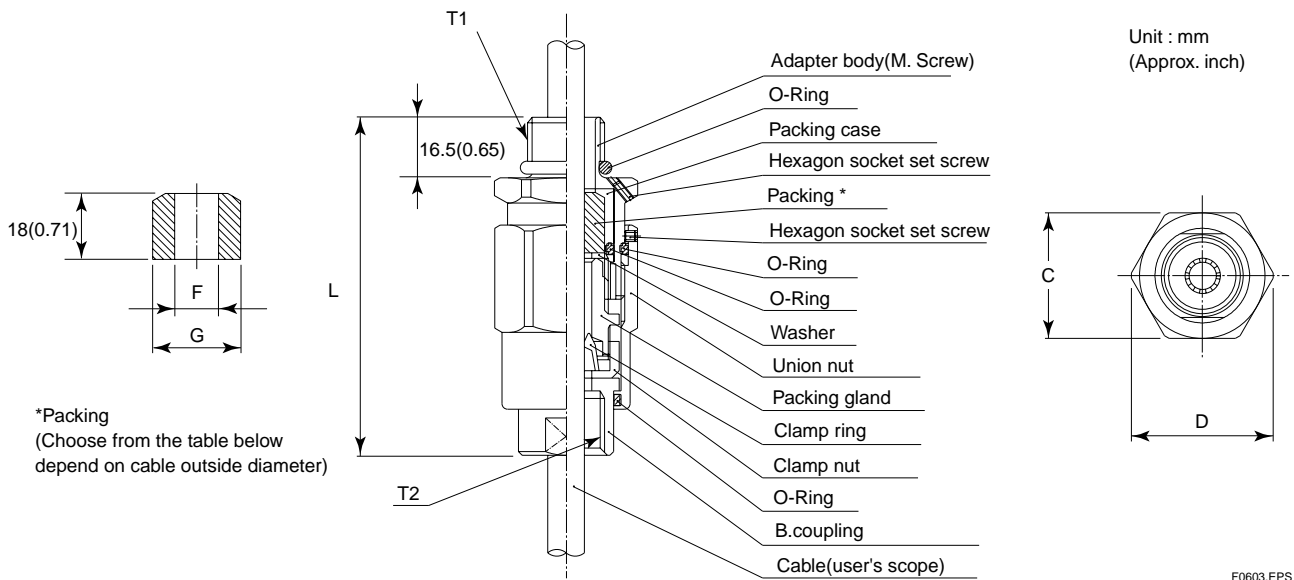

Dimension					Cable outer diameter	Packing diameter		Identification mark	Weight kg (lb)
T1	T2	C	D	L		F	G		
G 1/2	G 1/2	35 (1.38)	39 (1.54)	94.5 (3.72)	φ8.0 to φ10.0 (0.31 to 0.39)	φ10.0(0.39)	φ20.0 (0.79)	16 8-10	0.26 (0.57)
					φ10.0 to φ12.0 (0.39 to 0.47)	φ12.0(0.47)		16 10-12	

Figure 6.4.1 Flame Proof Packing Adapter

Follow the procedure for flame proof packing adapter setting.

**CAUTION**

Before tightening, confirm cable length from terminals to flame proof packing adapter when setting. Once it is tightened, loosening and re-tightening may damage its sealing performance.

- (a) Measure the bi-direction of the cable outside diameter to one decimal place in mm.
- (b) Calculate the average of these value, and choose the suitable packing from attached two. [Refer to the figure. 6.4.1]
- (c) Screw the M.screw into the electrical connection. (Ensure O-ring)
- (d) Set union nut, B.coupling, clamp nut, clamp ring, packing gland, packing case with inserted packing and washer in that order around the cable, and tighten packing gland. And then tighten clamp nut. Confirm packing is compressed and cable is fixed.
- (e) Insert packing gland into M.screw.
- (f) Connect each wire of cable to terminal.
- (g) Tighten and fix union nut.
- (h) Tighten and fix hexagon socket set screw of M.screw and union nut.

# INSTALLATION AND OPERATING PRECAUTIONS FOR JIS FLAMEPROOF EQUIPMENT

## Apparatus Certified Under Technical Criteria (IEC-compatible Standards)

### 1. General

The following describes precautions on electrical apparatus of flameproof construction (hereinafter referred to as flameproof apparatus) in explosion-protected apparatus.

Following the Labour Safety and Health Laws of Japan, flameproof apparatus is subjected to type tests to meet either the technical criteria for explosionproof electrical machinery and equipment (standards notification no. 556 from the Japanese Ministry of Labour) (hereinafter referred to as technical criteria), in conformity with the IEC Standards, or the “Recommended Practice for Explosion-Protected Electrical Installations in General Industries,” published in 1979. These certified apparatus can be used in hazardous locations where explosive or inflammable gases or vapours may be present.

Certified apparatus includes a certification label and an equipment nameplate with the specifications necessary for explosion requirements as well as precautions on explosion protection. Please confirm these precautionary items and use them to meet specification requirements.

For electrical wiring and maintenance servicing, please refer to “Internal Wiring Rules” in the Electrical Installation Technical Standards as well as “USER’S GUIDELINES for Electrical Installations for Explosive Gas Atmospheres in General Industry,” published in 1994.

To meet flameproof requirements, equipment that can be termed “flameproof” must:

- (1) Be certified by a Japanese public authority in accordance with the Labour Safety and Health Laws of Japan and have a certification label in an appropriate location on its case, and
- (2) Be used in compliance with the specifications marked on its certification label, equipment nameplate and precautionary information furnished.

### 2. Electrical Apparatus of Flameproof Type of Explosion-Protected Construction

Electrical apparatus which is of flameproof construction is subjected to a type test and certified by the Japanese Ministry of Labour aiming at preventing explosion caused by electrical apparatus in a factory or any location where inflammable gases or vapours may be present. The flameproof

construction is of completely enclosed type and its enclosure shall endure explosive pressures in cases where explosive gases or vapours entering the enclosure cause explosion. In addition, the enclosure construction shall be such that flame caused by explosion does not ignite gases or vapours outside the enclosure.

In this manual, the word "flameproof" is applied to the flameproof equipment combined with the types of protection "e", "o", "i", and "d" as well as flameproof equipment.

### 3. Terminology

#### (1) Enclosure

An outer shell of an electrical apparatus, which encloses live parts and thus is needed to configure explosion-protected construction.

#### (2) Shroud

A component part which is so designed that the fastening of joint surfaces cannot be loosened unless a special tool is used.

#### (3) Enclosure internal volume

This is indicated by:— the total internal volume of the flameproof enclosure minus the volume of the internal components essential to equipment functions.

#### (4) Path length of joint surface

On a joint surface, the length of the shortest path through which flame flows from the inside to outside of the flameproof enclosure. This definition cannot be applied to threaded joints.

#### (5) Gaps between joint surfaces

The physical distance between two mating surfaces, or differences in diameters if the mating surfaces are cylindrical.

Note: The permissible sizes of gaps between joint surfaces, the path length of a joint surface and the number of joint threads are determined by such factors as the enclosure’s internal volume, joint and mating surface construction, and the explosion classification of the specified gases and vapours.

## 4. Installation of Flameproof Apparatus

### (1) Installation Area

Flameproof apparatus may be installed, in accordance with applicable gases, in a hazardous area in Zone 1 or 2, where the specified gases are present. Those apparatus shall not be installed in a hazardous area in Zone 0.

Note: Hazardous areas are classified in zones based upon the frequency of the appearance and the duration of an explosive gas atmosphere as follows:

Zone 0: An area in which an explosive gas atmosphere is present continuously or is present for long periods.

Zone 1: An area in which an explosive gas atmosphere is likely to occur in normal operation.

Zone 2: An area in which an explosive gas atmosphere is not likely to occur in normal operation and if it does occur it will exist for a short period only.

### (2) Environmental Conditions

The standard environmental condition for the installation of flameproof apparatus is limited to an ambient temperature range from  $-20^{\circ}\text{C}$  to  $+40^{\circ}\text{C}$  (for products certified under Technical Criteria). However, some field-mounted instruments may be certified at an ambient temperature up to  $+60^{\circ}\text{C}$  as indicated on the instrument nameplates. If the flameproof apparatus are exposed to direct sunshine or radiant heat from plant facilities, appropriate thermal protection measures shall be taken.

## 5. External Wiring for Flameproof Apparatus

Flameproof apparatus require cable wiring or flameproof metal conduits for their electrical connections. For cable wiring, cable glands (cable entry devices for flameproof type) to wiring connections shall be attached. For metal conduits, attach sealing fittings as close to wiring connections as possible and completely seal the apparatus. All non-live metal parts such as the enclosure shall be securely grounded. For details, see the "USER'S GUIDELINES for Electrical Installations for Explosive Gas Atmospheres in General Industry," published in 1994.

### (1) Cable Wiring

- Specific cables shall be used as recommended by the "USER'S GUIDELINES for Electrical Installations for Explosive Gas Atmospheres in General Industry," published in 1994.
- In necessary, appropriate protective pipes (conduit or flexible pipes), ducts or trays shall be used for preventing the cable run (outside the cable glands) from damage.
- To prevent explosive atmosphere from being propagated from Zone 1 or 2 hazardous location to any different location or non-hazardous location through the protective pipe or duct, apply sealing of the protective pipes in the vicinity of individual boundaries, or fill the ducts with sand appropriately.
- When branch connections of cables, or cable connections with insulated cables inside the conduit pipes are made, a flameproof or increased-safety connection box shall be used. In this case, flameproof or increased-safety cable glands meeting the type of connection box must be used for cable connections to the box.

### (2) Flameproof Metal Conduit Wiring

- For the flameproof metal conduit wiring or insulated wires shall be used as recommended by the USER'S GUIDELINES for Electrical Installations for Explosive Gas Atmospheres in General Industry, published in 1994.
- For conduit pipes, heavy-gauge steel conduits conforming to JIS C 8305 Standard shall be used.
- Flameproof sealing fittings shall be used in the vicinity of the wiring connections, and those fittings shall be filled with sealing compounds to complete sealing of the apparatus. In addition, to prevent explosive gases, moisture, or flame caused by explosion from being propagated through the conduit, always provide sealing fittings to complete sealing of the conduit in the following locations:
  - (a) In the boundaries between the hazardous and non-hazardous locations.
  - (b) In the boundaries where there is a different classification of hazardous location.
- For the connections of the apparatus with a conduit pipe or its associated accessories, G-type parallel pipe threads (JIS B 0202) shall be used to provide a minimum of five-thread engagement to complete tightness. In addition, since these parallel threads do not have sealing property, nonhardening sealant such as liquid gaskets shall thus be applied to those threads for ensuring waterproofness.
- If metal conduits need flexibility, use flameproof flexible fittings.

## 6. Maintenance of Flameproof Apparatus

To maintain the flameproof apparatus, do the following. (For details, see Chapter 10 “MAINTENANCE OF EXPLOSION-PROTECTED ELECTRICAL INSTALLATION” in the USER’S GUIDELINES for Electrical Installations for Explosive Gas Atmospheres in General Industry.)

### (1) Maintenance servicing with the power on.

Flameproof apparatus shall not be maintenance-serviced with its power turned on. However, in cases where maintenance servicing is to be conducted with the power turned on, with the equipment cover removed, always use a gas detector to check that there is no explosive gas in that location. If it cannot be checked whether an explosive gas is present or not, maintenance servicing shall be limited to the following two items:

- (a) Visual inspection  
Visually inspect the flameproof apparatus, metal conduits, and cables for damage or corrosion, and other mechanical and structural defects.
- (b) Zero and span adjustments  
These adjustments should be made only to the extent that they can be conducted from the outside without opening the equipment cover. In doing this, great care must be taken not to cause mechanical sparks with tools.

### (2) Repair

If the flameproof apparatus requires repair, turn off the power and transport it to a safety (non-hazardous) location. Observe the following points before attempting to repair the apparatus.

- (a) Make only such electrical and mechanical repairs as will restore the apparatus to its original condition. For the flameproof apparatus, the gaps and path lengths of joints and mating surfaces, and mechanical strength of enclosures are critical factors in explosion protection. Exercise great care not to damage the joints or shock the enclosure.
- (b) If any damage occurs in threads, joints or mating surfaces, inspection windows, connections between the transmitter and terminal box, shrouds or clamps, or external wiring connections which are essential in flameproofness, contact Yokogawa Electric Corporation.



### CAUTION

Do not attempt to re-process threaded connections or refinish joints or mating surfaces.

- (c) Unless otherwise specified, the electrical circuitry and internal mechanisms may be repaired by component replacement, as this will not directly affect the

requirements for flameproof apparatus (however, bear in mind that the apparatus must always be restored to its original condition). If you attempt to repair the flameproof apparatus, company-specified components shall be used.

- (d) Before starting to service the apparatus, be sure to check all parts necessary for retaining the requirements for flameproof apparatus. For this, check that all screws, bolts, nuts, and threaded connections have properly been tightened.

### (3) Prohibition of specification changes and modifications

Do not attempt to change specifications or make modifications involving addition of or changes in external wiring connections.

## 7. Selection of Cable Entry Devices for Flameproof Type



### IMPORTANT

The cable glands (cable entry devices for flameproof type) conforming to IEC Standards are certified in combination with the flameproof apparatus. So, Yokogawa-specified cable entry devices for flameproof type shall be used to meet this demand.

### References:

- (1) Type Certificate Guide for Explosion-Protected Construction Electrical Machinery and Equipment (relating to Technical Standards Conforming to International Standards), issued by the Technical Institution of Industrial Safety, Japan
- (2) USER’S GUIDELINES for Electrical Installations for Explosive Gas Atmospheres in General Industry (1994), issued by the Japanese Ministry of Labour, the Research Institute of Industrial Safet