

Contents

Introduction	2
1. Combining AXF Flowtubes with Existing Converters	3
1.1 Combination between AM11 and AXF Flowtubes	3
1.2 Combination between AE14 and AXF Flowtubes	3
1.3 Combination between YMA11 and AXF Flowtubes	4
2. Combining AXFA Converters with Existing Flowtubes	7
2.1 Combination between AM Flowtubes and AXFA11	8
(Combination between AM Flowtubes and AXFA14)	
2.2 Combination between AE Flowtubes and AXFA14	9
(Combination between AE Flowtubes and AXFA11)	
2.3 Combination between SE Flowtubes and AXFA11	10
2.4 Combination between YM Flowtubes and AXFA11	11
2.5 Combination between Flowtubes of Other Manufacturers and AXFA11	13
3. How to Check the Performance of Existing Flowtubes	16
4. How to Obtain Meter Factor using the Customer's Flow Line	17
4.1 How to Perform Flow Calibration in Combination with AXFA11 using the Customer's Facilities	17
4.2 How to Obtain Meter Factor by Incorporating the Indicated Flow Rate of the Existing Converter.	18
4.3 How to Obtain Meter Factor According to the Inferred Flow Rates Such as Valve Openings or Pump Rpm	19
5. Compatibility with AXFA11 and AXFA14	20
Appendix. 1 Electrical Connection	21
(1) Combination AXFA11 and FOXBORO 1800 Series	22
(2) Combination AXFA11 and FOXBORO 2800 Series	24
(3) Combination AXFA11 and F&P 10D1418 Series	26
(4) Combination AXFA11 and F&P 10D1419 Series	28
(5) Combination AXFA11 and F&P 10D1430 Series	29
(6) Combination AXFA11 and F&P 10D1435 (MAGX) Series (6" to 48")	31
(7) Combination AXFA11 and F&P 10D1475 (MINI MAGX) Series	32
(8) Combination AXFA11 and BROOKS 7000 Series	33
(9) Combination AXFA11 and BROOKS 7100 Series	34
(10) Combination AXFA11 and BROOKS 7400 Series	35
(11) Combination AXFA11 and BROOKS 7500 Series	36
(12) Combination AXFA11 and KROHNE ALTFLUX X-1000, M900 Series	37
(13) Combination AXFA11 and ROSEMOUNT 8701	39
(14) Combination AXFA11 and TAYLOR 1100 Series	40

Introduction

This technical information describes how to combine ADMAG AXF magnetic flowmeters with existing remote type flowtubes or converters. A magnetic flowmeter is used by obtaining a meter factor, which is a calibration coefficient unique to a flowtube, according to flow calibration and then by setting the meter factor to a converter. Values of meter factors depend on the models of converters to be combined. Therefore, in order to measure flow rates with high accuracy, flow calibration must be re-performed at the factory. If this is not possible, refer to additional errors and meter factor conversion coefficients described in this technical information.

There are various precautions for combinations with existing instruments. In some cases, such instruments cannot be combined or require settings by Yokogawa's service personnel. Read this technical information carefully and take appropriate measures.

Possible Combinations between Existing Remote Type Flowtubes/Converters and ADMAG AXF Series

Converters Flowtubes	AXFA11	AXFA14	AM11	AE14	SE14	YMA11	Converters of Other Manufacturers
AXF Flowtube	—		Section 1.1	Section 1.2	Not possible	Section 1.3	Not possible
AM Flowtube	Section 2.1	See Note in Section 2.1					
AE Flowtube	See Note in Section 2.2	Section 2.2					
SE Flowtube	Section 2.3	Not possible					
YM Flowtube	Section 2.4	Not possible					
Flowtubes of Other Manufacturers	Section 2.5	Not possible					

T01.EPS

Note: Even if a flowtube is an explosion-proof type, the explosion-proof capability is not satisfied if the flowtube is combined with a different model. If the explosion-proof capability is required, the flowtube must be used in the combination specified for the same model.

1. Combining AXF Flowtubes with Existing Converters

Note 1: For combinations between an existing converter and an AXF flowtube, only AM11, AE14 and YMA11 can be used. Other converters (SE14 and converters of other companies) cannot be combined with AXF flowtubes.

Note 2: Even if flow calibration is redone, functions and capabilities are equivalent to those of existing instruments. The functions unique to AXF such as enhanced dual frequency excitation cannot be used.

1.1 Combination between AM11 and AXF Flowtubes

1.1.1 When newly purchasing AXF flowtubes

- Issue a Tokuchu request for purchasing AXF flowtubes. In this case, the enhanced dual frequency excitation function (option codes /HF1 and /HF2) cannot be selected. In the Tokuchu request, be sure to enter a model name of an existing converter (a full model and suffix code) and indicate clearly that an AXF flowtube will be combined with this converter.
- In addition to the regular flow calibration with AXFA converters, flow calibration in combination with AM11 is performed and then both meter factors are inscribed on the data plate. Set the meter factor for AM11 to AM11 before operation. The accuracy in this case will be the same as AM.

Note: Meter factors for combinations differ, depending on whether an existing converter is AM11-AS/DH/DB or AM11-DL. Therefore, be sure to state a full model and suffix code clearly in a Tokuchu request.

1.1.2 When using existing or stock AXF flowtubes

■ Combination with AM11-AS, DH or DB

- It is recommended that flow calibration be redone for the AXF flowtubes at Yokogawa's factory. The accuracy in this case will be the same as AM.
- If flow calibration cannot be redone at Yokogawa's factory, set the meter factors (both the low MF value and the high MF value) inscribed on AXF flowtubes to AM11 as they are. The accuracy for reference in this case will be approximately AM accuracy \pm additional 0.5% for flowtubes for AXFA11 (model name: AXFxxxx-N) and approximately AM accuracy \pm additional 1.5% for flowtubes for AXFA14 (model name: AXFxxxx-P).

■ Combination with AM11-DL

- Flow calibration must be redone for the AXF flowtubes at Yokogawa's factory. The accuracy in this case will be the same as AM.
- If flow calibration cannot be redone at Yokogawa's factory, contact Yokogawa. Since meter factors differ substantially for combination with the DL-type, meter factors inscribed on the AXF flowtubes cannot be set for use as they are.

1.2 Combination between AE14 and AXF Flowtubes

Note: Sizes of the flowtubes which can be combined with AE14 are 2.5 mm (0.1 in.) to 400 mm (16 in.) only.

1.2.1 When newly purchasing AXF flowtubes

- Issue a Tokuchu request for purchasing AXF flowtubes. In this case, the enhanced dual frequency excitation function (option codes /HF1 and /HF2) cannot be selected. In the Tokuchu request, be sure to indicate clearly that AXF flowtubes will be combined with AE14.
- In addition to the regular flow calibration with AXFA converters, flow calibration in combination with AE14 is performed and then both meter factors are inscribed on the data plate. Set the meter factor for AE14 to AE14 before operation. The accuracy in this case will be the same as AE.

1.2.2 When using existing or stock AXF flowtubes

- It is recommended that flow calibration be redone for the AXF flowtubes at Yokogawa's factory. The accuracy in this case will be the same as AE.
- If flow calibration cannot be redone at Yokogawa's factory, set the meter factors (both the low MF value and the high MF value) inscribed on AXF flowtubes to AE14 as they are. The accuracy for reference in this case will be approximately AE accuracy \pm additional 0.5% for flowtubes for AXFA14 (model name: AXFxxxx-P) and approximately AE accuracy \pm additional 1.5% for flowtubes for AXFA11 (model name: AXFxxxx-N).

1.3 Combination between YMA11 and AXF Flowtubes

1.3.1 When newly purchasing AXF flowtubes

- Issue a Tokuchu request for purchasing AXF flowtubes. In this case, the enhanced dual frequency excitation function (option codes /HF1 and /HF2) cannot be selected. In the Tokuchu request, be sure to indicate clearly that AXF flowtubes will be combined with existing YMA11 converters.
- In addition to the regular flow calibration with AXFA converters, flow calibration in combination with YMA11 is performed and then both meter factors are inscribed on the data plate. Set the meter factor for YMA11 and an excitation current value to YMA11 before operation. Obtain a relevant excitation current value from Tables 1.3.1 to 1.3.3. The accuracy in this case will be the same as YM.

1.3.2 When using existing or stock AXF flowtubes

- It is recommended that flow calibration be redone for the AXF flowtubes at Yokogawa's factory. The accuracy in this case will be the same as YM.
- If flow calibration cannot be redone at Yokogawa's factory and if a flowtube for AXFA11 (AXFxxxx-N) is used, obtain a necessary excitation current value and an approximate meter factor value from Tables 1.3.1 to 1.3.3, and combine the flowtube with YMA11. The meter factor for YMA11 is obtained by multiplying the low meter factor (the meter factor inscribed on the "METER FACTOR L" section of the data plate) of the AXF flowtube with a coefficient in Tables 1.3.1 to 1.3.3. Although the accuracy in this case is not guaranteed, it will be approximately YM accuracy \pm additional 2% as a reference. Also, the excitation current value needs to be set to YMA11.
- Flowtubes for AXFA14 (AXFxxxx-P) cannot be combined with YMA11 without redoing flow calibration.
- AXF flowtubes with the size of 32 mm (1.25 in.), 65 mm (2.5 in.) or 125 mm (5 in.) cannot be combined with YMA11.

Table 1.3.1 Combination between AXF Ceramic Lining Flowtubes and YMA11

Meter factor for YMA11 = Low meter factor for AXF flowtube × coefficient in the table below					
Size of AXF Flowtube [mm (in.)]	YMA11 Excitation Current Setting Value (A)	Coefficient in 1/8 Mode Excitation		Coefficient in 1/2 Mode Excitation	
		50 Hz Area	60 Hz Area	50 Hz Area	60 Hz Area
2.5 (0.1)	0.12	1.0304	1.0313	1.0232	1.0205
5 (0.2)	0.13	0.9771	0.9757	0.9760	0.9730
10 (0.4)	0.22	0.6542	0.9542	0.95	0.9487
15 (0.5)	0.22	0.9589	0.9584	0.9589	0.9583
25 (1.0)	0.14	0.9756	0.976	0.9748	0.9746
40 (1.5)	0.13	0.9723	0.9724	0.9732	0.9717
50 (2.0)	0.12	0.9697	0.9691	0.9683	0.9675
80 (3.0)	0.16	0.9701	0.9688	0.9673	0.9658
100 (4.0)	0.14	0.9619	0.9602	0.9567	0.9546
150 (6.0)	0.11	0.9672	0.9661	0.9639	0.9603
200 (8.0)	0.12	0.9666	0.9661	0.9596	0.9550

T02.EPS

Table 1.3.2 Combination between AXF PFA Lining Flowtubes and YMA11

Meter factor for YMA11 = Low meter factor for AXF flowtube × coefficient in the table below					
Size of AXF Flowtube [mm (in.)]	YMA11 Excitation Current Setting Value (A)	Coefficient in 1/8 Mode Excitation		Coefficient in 1/2 Mode Excitation	
		50 Hz Area	60 Hz Area	50 Hz Area	60 Hz Area
2.5 (0.1)	0.12	1.0127	1.0162	1.0092	1.006
5 (0.2)	0.14	0.9786	0.9788	0.9763	0.975
10 (0.4)	0.23	0.94	0.9403	0.9351	0.9335
15 (0.5)	0.23	0.9423	0.9419	0.9398	0.9399
25 (1.0)	0.15	0.9755	0.976	0.9746	0.9747
40 (1.5)	0.13	0.9727	0.9719	0.9716	0.9708
50 (2.0)	0.13	0.9728	0.9725	0.9715	0.9705
80 (3.0)	0.17	0.9741	0.9726	0.9701	0.9674
100 (4.0)	0.14	0.9635	0.9625	0.9562	0.9526
150 (6.0)	0.11	0.9796	0.9779	0.9679	0.9613
200 (8.0)	0.12	0.9767	0.9759	0.9756	0.9468
250 (10.0)	0.5	0.9924	0.9925	0.9595	0.9483
300 (12.0)	0.5	0.9864	0.9855	0.9435	0.9265
350 (14.0)	0.5	*	*	*	*
400 (16.0)	0.5	0.9844	0.9841	0.9367	0.9193

T03.EPS

For "*" sections in the table, contact Yokogawa.

Table 1.3.3 Combination between AXF Polyurethane Lining Flowtubes and YMA11

Meter factor for YMA11 = Low meter factor for AXF flowtube × coefficient in the table below

Size of AXF Flowtube [mm (in.)]	YMA11 Excitation Current Setting Value (A)	Coefficient in 1/8 Mode Excitation		Coefficient in 1/2 Mode Excitation	
		50 Hz Area	60 Hz Area	50 Hz Area	60 Hz Area
25 (1.0)	0.2	0.9841	0.9835	0.9840	0.9838
40 (1.5)	*	*	*	*	*
50 (2.0)	*	*	*	*	*
80 (3.0)	0.23	0.9836	0.9821	0.972	0.9701
100 (4.0)	0.2	0.9562	0.9553	0.9491	0.9452
150 (6.0)	0.15	0.9845	0.9827	0.9742	0.9684
200 (8.0)	0.17	0.9818	0.9802	0.9621	0.9519

T04.EPS

For " * " sections in the table, contact Yokogawa.

2. Combining AXFA Converters with Existing Flowtubes

Note: In some cases, these instruments cannot be combined. Even if they can be combined, it is strongly recommended to redo flow calibration if existing flowtubes are Yokogawa's products. The accuracy in this case will be the standard accuracy of the existing flowtubes. If flow calibration cannot be redone or if AXFA converters need to be combined with flowtubes of other manufacturers, meter factors based on calculations or on-site actual flow tests shall be incorporated. Note that the accuracy is not guaranteed in this case. It may also not be possible to provide additional errors for reference.

Outline of procedures

• For details, see Sections 2.1 to 2.5.

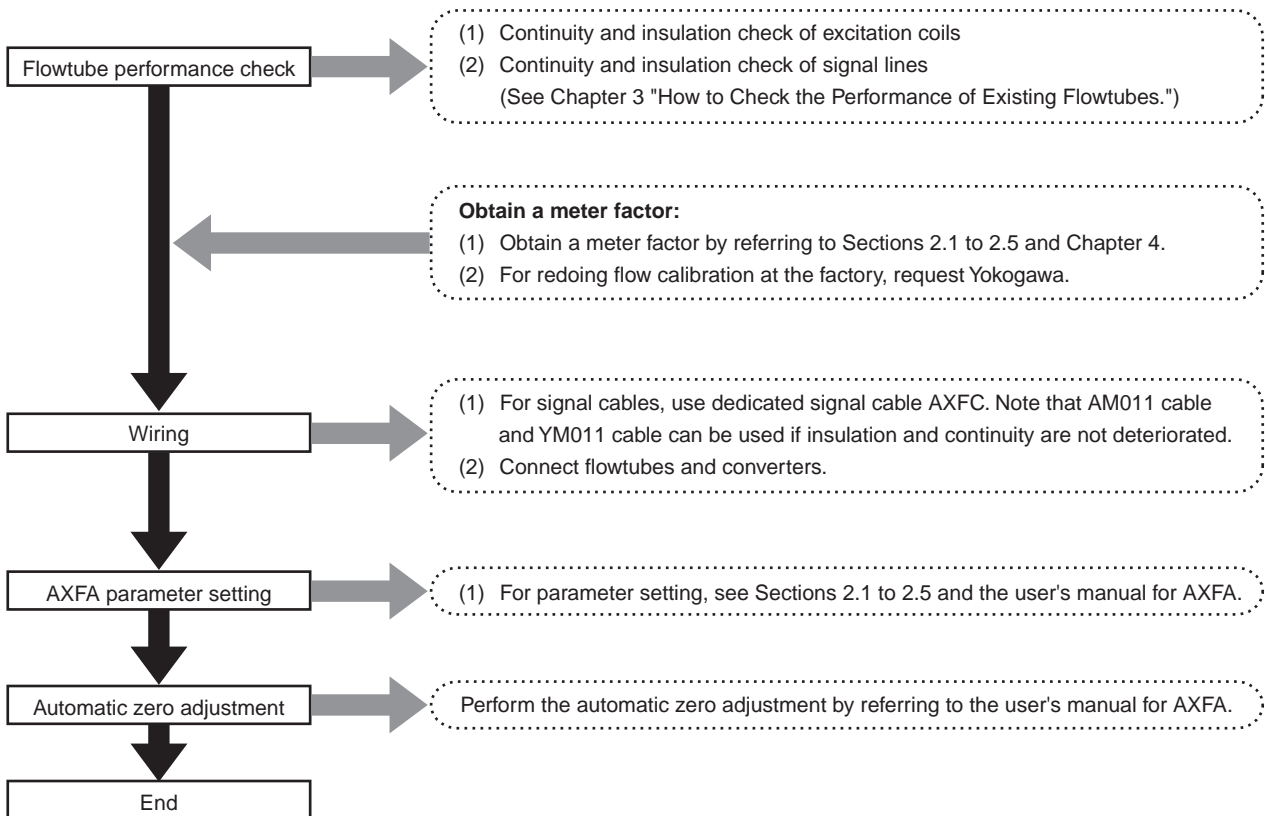

F01.EPS

2.1 Combination between AM Flowtubes and AXFA11

2.1.1 Flowtube performance check

Based on Chapter 3 "How to Check the Performance of Existing Flowtubes," check that an existing flowtube is not damaged.

2.1.2 Obtaining the meter factors

Obtain the meter factors by either of the following two methods a) or b) depending on the situation:

a) By obtaining the meter factors by redoing flow calibration at Yokogawa's factory

The accuracy in this case will be the same as AM.

b) By using the meter factors of AM

- For the sizes from 2.5 mm (0.1 in.) to 1000 mm (40 in.) and the sizes from 1100 mm (44 in.) to 2600 mm (104 in.) style A or style B (model code: AM5xxx.....*A or *B), the meter factors inscribed on AM flowtubes can be set to AXFA11 as they are. The accuracy for reference in this case will be approximately AM accuracy \pm additional 0.5%.

- If the existing flowtube is 1100 mm (44 in.) to 2600 mm (104 in.) style C (model code: AM5xxx.....*C), the AM's meter factor cannot be set to AXFA11 as it is, because the meter factor in combination with AXFA11 differs substantially. Contact Yokogawa for how to deal with such situations.

2.1.3 Wiring

Connect the AM flowtube with AXFA11.

The wiring is the same as in the case of connecting AXF flowtubes with AXFA11.

2.1.4 Parameter setting

Set the following parameters to AXFA11:

- Select "ADMAG" in the parameter "C30: Select Flow Tube." Flowtubes with the size of 400 mm (16 in.) or smaller are driven with dual frequency excitation, while those with the size of 500 mm (20 in.) or larger are driven with pulsed DC calculation. The enhanced dual frequency excitation function cannot be used.
- Set both "C21: Low MF" and "C22: High MF" as meter factors for flowtubes with the sizes from 2.5 mm (0.1 in.) to 400 mm (16 in.). Set "C21: Low MF" as the meter factor for flowtubes with the sizes from 500 mm (20 in.) to 2600 (104 in.) mm, and set 1.0000 to "C22: High MF."
- For the sizes from 1100 mm (44 in.) to 2600 mm (104 in.), select "No" in the parameter "J30: Power Synch" and set "49.00" to "J31: Power Frequency."
- For details on setting parameters other than the above, follow the user's manual for AXFA11.

2.1.5 Zero adjustment

Perform the automatic zero adjustment according to the user's manual for AXFA11.

End

Note: Combinations between AM flowtubes and AXFA14 can also be operated using the same procedure. However, in "b) By using the meter factors of AM" of Section 2.1.2 "Obtaining the meter factors," the accuracy for reference will be approximately AM accuracy \pm additional 1.5%. Moreover, in the case of the sizes from 250 mm (10 in.) to 400 mm (16 in.), output fluctuations may become larger than in the case of operations using AXFA11 due to EMF differences. Note that combinations between AM flowtubes and AXFA14 are only possible for the sizes from 2.5 mm (0.1 in.) to 400 mm (16 in.). There is no need to set the parameter "C30: Select Flow Tube" (there is no parameter "C30" in AXFA14).

2.2 Combination between AE Flowtubes and AXFA14

2.2.1 Flowtube performance check



Based on Chapter 3 "How to Check the Performance of Existing Flowtubes," check that an existing flowtube is not damaged.

2.2.2 Obtaining the meter factors



Obtain the meter factors by either of the following two methods a) or b) depending on the situation:

a) By obtaining the meter factors by redoing flow calibration at Yokogawa's factory

The accuracy in this case will be the same as AE.

b) By using the meter factors of AE

The meter factors inscribed on AE flowtubes can be set to AXFA14 as they are.

The accuracy for reference in this case will be approximately AE accuracy \pm additional 0.5%.

2.2.3 Wiring



Connect the AE flowtube with AXFA14.
The wiring is the same as in the case of connecting AXF flowtubes with AXFA14.

2.2.4 Parameter setting



Set the following parameters to AXFA14:

- Set both "C21: Low MF" and "C22: High MF" as meter factors.
- For details on setting parameters other than the above, follow the user's manual for AXFA14.

Note: AE flowtubes are driven with dual frequency excitation. The enhanced dual frequency excitation function cannot be used.

2.2.5 Zero adjustment



Perform the automatic zero adjustment according to the user's manual for AXFA14.

End

Note: Combinations between AE flowtubes and AXFA11 can also be operated using the same procedure. However, in "b) By using the meter factors of AE" of Section 2.2.2 "Obtaining the meter factors," the accuracy for reference will be approximately AE accuracy \pm additional 1.5%. Select "ADMAG AE" in the parameter "C30: Select Flow Tube" for AXFA11.

2.3 Combination between SE Flowtubes and AXFA11

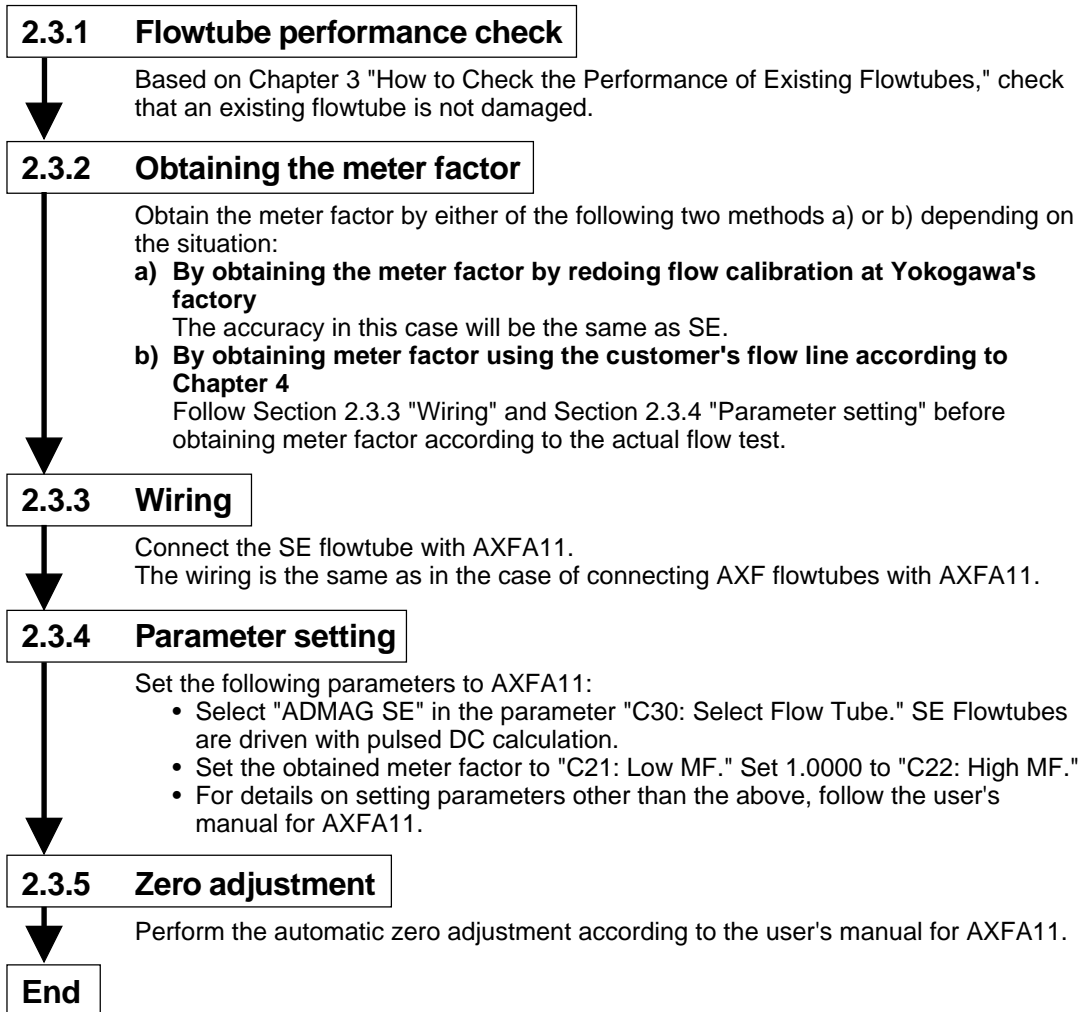

Note 1: Meter factors of SE flowtubes cannot be used for setting as they are, as meter factors differ substantially in the combinations between SE flowtubes and AXFA11.

Note 2: AXFA14 cannot be combined with SE flowtubes, as it cannot drive the SE flowtubes.

2.4 Combination between YM Flowtubes and AXFA11

2.4.1 Flowtube performance check

Based on Chapter 3 "How to Check the Performance of Existing Flowtubes," check that an existing flowtube is not damaged.

2.4.2 Obtaining the meter factor

Obtain the meter factor by either one of the following three methods a), b) and c), depending on the situation:

a) By obtaining the meter factor by redoing flow calibration at Yokogawa's factory

The accuracy in this case will be the same as YM.

b) By calculating from the meter factor of YM

The accuracy for reference will be approximately YM accuracy \pm additional 1%.

- (1) Read the meter factor in 1/8 mode (standard mode) and 50 Hz from the data plate of a YEW MAG flowtube.
- (2) The meter factor is obtained by multiplying the YM meter factor in 1/8 mode and 50 Hz by a coefficient determined for each size shown in Table 2.4 "Meter Factor Calculation Coefficient Table".

Example:

YM102 1/8 mode, 50 Hz	Meter factor: 0.2800
-----------------------	----------------------

50 Hz area:

Meter factor: $0.2800 \times 1.0825 = 0.3031$

60 Hz area:

Meter factor: $0.2800 \times 1.0820 = 0.3030$

c) By obtaining meter factor using the customer's flow line according to Chapter 4

Follow Section 2.4.3 "Wiring" and Section 2.4.4 "Parameter setting" before obtaining meter factor according to the actual flow test.

2.4.3 Wiring

Connect the YM flowtube with AXFA11.

The wiring is the same as in the case of connecting AXF flowtubes with AXFA11.

Note that, if BARD is used for a YM explosion-proof type flowtube, remove the BARD and use the flowtube as a non-explosion-proof type product. This combination cannot satisfy the requirements of explosion-proof capabilities.

2.4.4 Parameter setting

Set the following parameters to AXFA11:

- Select "YEW MAG" in the parameter "C30: Select Flow Tube."
- Check the software revision number of AXFA11 which is indicated in the parameter "J50: Software Rev No."

If the revision number is "R1.05" or "R1.08":

Select "Low" in the service parameter (not disclosed) "U15: 4-20mA Sel."

Be sure to contact Yokogawa for the service parameter setting. Pulsed DC calculations apply to all sizes.

If the revision number is other than "R1.05" or "R1.08":

There is no need to set "U15: 4-20mA Sel." Pulsed DC calculations automatically apply to all sizes by selecting "YEW MAG" in the parameter "C30: Select Flow Tube" as above.

- Set the obtained meter factor to "C21: Low MF." Set 1.0000 to "C22: High MF."
- For the sizes from 1100 mm (44 in.) to 2600 mm (104 in.), select "No" in the parameter "J30: Power Synch" and set "49.00" to "J31: Power Frequency."
- For details on setting parameters other than the above, follow the user's manual for AXFA11.

(To the next page)

↓
2.4.5 Zero adjustment

↓ Perform the automatic zero adjustment according to the AXFA11 user's manual.

End

Note: AXFA14 cannot be combined with YM flowtubes, as it cannot operate the YM flowtubes.

Table 2.4 List of Meter Factor Calculation Coefficients

	50 Hz Area	60 Hz Area
YM102	1.0825	1.0820
YM104	1.0541	1.0545
YM106	1.0417	1.0448
YM115	1.1184	1.1185
YM202	1.0633	1.0633
YM204	1.0181	1.0170
YM205	1.0124	1.0123
YM208	1.0120	1.0122
YM210	1.0124	1.0152
YM315	1.0095	1.0098
YM320	1.0053	1.0065
YM325	1.0185	1.0170
YM330	1.0251	1.0249
YM335	1.0250	1.0263
YM340	1.0506	1.0537
YM405	1.0180	1.0179
YM406	1.0195	1.0201
YM407	1.0224	1.0217
YM408	1.0252	1.0254
YM409	1.0198	1.0206

T05.EPS

2.5 Combination between Flowtubes of Other Manufacturers and AXFA11

Note: It may not be possible to operate some flowtubes of other manufacturers due to the difference in magnetic circuits. Although the coil resistance of a flowtube must be 240 Ω or less, it may not be possible to operate the flowtube even if the resistance is 240 Ω or less. Especially, if the excitation current of an existing model is designed to be 0.26 mA or less, it is more likely that the flowtube cannot be driven by AXFA11.

2.5.1 Flowtube performance check



Based on Chapter 3 "How to Check the Performance of Existing Flowtubes," check that an existing flowtube is not damaged.

2.5.2 Obtaining the meter factor

Obtain the meter factor by one of the following three methods a), b) and c), depending on the situation:

a) By obtaining meter factor using the customer's flow line according to Chapter 4

Follow Section 2.5.3 "wiring" and Section 2.5.4 "Parameter setting" before obtaining meter factor according to the actual flow test.

b) By obtaining meter factor through calculation

The calculated meter factor is an approximation. Calculations must be performed when it is difficult to obtain a meter factor according to the actual flow test. Accuracy for reference cannot be provided.

Driving methods of existing flowtubes

(Known) Model Name	Method	Relevant Section
	Reference voltage method	b.1)
FOXBORO 1800 and 2800 series	Flowtube inscribed with C/F/P	b.2)
	Flowtube inscribed with generated EMF	b.3)

T06.EPS

* FOXBORO 1800 and 2800 series have two types: C/F/P is inscribed on one type, while the generated EMF is inscribed on the other. Check the types shown in the data plate. Both C/F/P and the generated EMF may be inscribed on some models. In this case, use C/F/P for calculation.

b.1) Reference voltage method

Reference voltage ("Reference.v") is inscribed on the data plate or CP unit (open the terminal box cover). Calculate the meter factor using the reference voltage:

$$\text{Meter factor for FOXBORO 1800 and 2800 series} = \frac{\text{Reference voltage (v)}}{5 \times \text{excitation current}}$$



(To the next page)

- b.2) Flowtube inscribed with C/F/P
If C/F/P is inscribed on the data plate, calculate the meter factor as follows:

$$\text{Meter factor} = \frac{C \times F}{10 \times \text{span flow velocity (m/s)}}$$

- b.3) Flowtube inscribed with generated EMF
If the generated EMF is inscribed on the data plate and if the excitation current value is already known, calculate the meter factor as follows.

$$\text{Meter factor} = \frac{\text{Generated EMF per 1 m/s}}{\text{Excitation current value of an existing instrument}}$$

How to obtain the generated EMF per 1 m/s:

Example) If the size is 25 mm (1 in.) and the generated EMF is 0.0540 mV (m³/h):

The generated EMF of 0.0540 mV (m³/h) means that "the EMF to be generated when the flow rate is 1 m³/h is 0.0540 mV."

The flow velocity for size 25 mm (1 in.) when the flow rate is 1 m³/h:

$$\begin{aligned} \text{Flow velocity } V(\text{m/s}) &= \frac{4}{\pi D^2(\text{m})} \times Q(\text{m}^3/\text{s}) \\ &= \frac{4}{3.14 \times (0.025(\text{m}))^2} \times \frac{1}{3600} (\text{m}^3/\text{s}) = 0.566(\text{m/s}) \end{aligned}$$

where,

D: Nominal size (to be set in units of m)

Q: Flow rate (to be set in m³/s)

Since the generated EMF for 1 m³/h (= 0.566 m/s) is 0.054 mV, the generated EMF for 1 m/s will be:

$$0.0540 \text{ mV} \times \frac{1}{0.566} = 0.0954 \text{ mV}$$

- c) **By using an already-known approximate meter factor**

Approximate meter factors of the FOXBORO 1800 and 2800 series are already known. They are shown in Appendix 1 "Wiring". Since these values are approximations, they shall be used when it is difficult to obtain meter factors using actual flow tests or through calculations. Accuracy for reference cannot be provided.

2.5.3 Wiring

Connect the flowtubes of other manufacturers with AXFA11. For reference, see Appendix 1 "Wiring" which contains known and available information.

2.5.4 Parameter setting

Set the following parameters to AXFA11:

- Check the software revision number of AXFA11 which is indicated in the parameter "J50: Software Rev No."

If the revision number is "R1.05" or "R1.08":

- (1) Select "YEW MAG" or "Calibrator" in the parameter "C30: Select Flow Tube":
"YEW MAG" if the flowtube's coil resistance is 60 Ω or less.
"Calibrator" if the flowtube's coil resistance is 61 Ω to 240 Ω.
- (2) Select "Low" in the service parameter (not disclosed) "U15: 4-20mA Sel." Be sure to contact Yokogawa for the service parameter setting. Pulsed DC calculations apply to all sizes.

If the revision number is other than "R1.05" or "R1.08":

- (1) Select "YEW MAG" or "Other" in the parameter "C30: Select Flow Tube":
"YEW MAG" if the flowtube's coil resistance is 60 Ω or less.
"Other" if the flowtube's coil resistance is 61 Ω to 240 Ω.

There is no need to set "U15: 4-20mA Sel." Pulsed DC calculations automatically apply to all sizes by selecting "YEW MAG" or "Other" in the parameter "C30: Select Flow Tube."

(To the next page)



- Set the obtained meter factor to "C21: Low MF." Set 1.0000 to "C22: High MF."
- For details on setting parameters other than the above, follow the user's manual for AXFA11.

2.5.5 Zero adjustment



Perform the automatic zero adjustment according to the user's manual for AXFA11.

End

Note: AXFA14 cannot be combined with flowtubes of other manufacturers.

3. How to Check the Performance of Existing Flowtubes

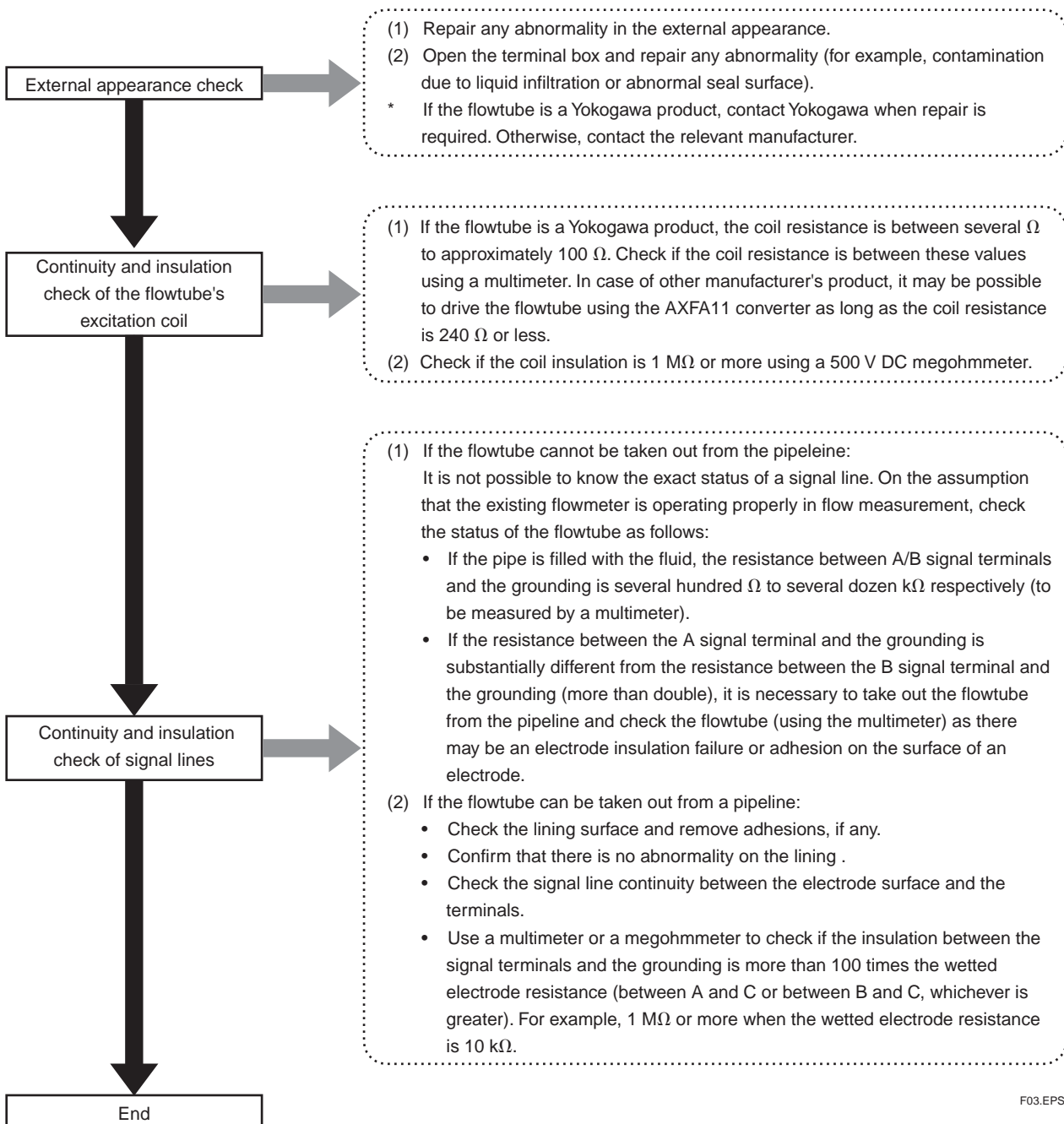

4. How to Obtain Meter Factor using the Customer's Flow Line

This chapter describes the following three methods to obtain meter factor using the customer's flow line by means of AXFA11 and an existing flowtube:

- Flow calibration in combination with AXFA11 using the customer's facilities
- Obtaining meter factor by incorporating the indicated flow rate of the existing converter.
- Using inferred flow rate such as valve openings or pump rpm

4.1 How to Perform Flow Calibration in Combination with AXFA11 using the Customer's Facilities

This method can be used if there is a tank or other vessel which can serve as a volumetric standard, or if another flow meter can be used as a master meter. The accuracy for reference in this case will be more than three times the accuracy of the volumetric standard or the reference meter, or the nominal accuracy of the flowtube, whichever is greater. As a rule, calibration should be performed by Yokogawa's service personnel.

4.1.1 Parameter setting



Set the size and span to AXFA11. The span shall be 1.5 to 2 times the flow rate (the same span as the one for the master meter if the master meter method is used). In addition, set the parameters according to any combination with relevant models in Chapter 2. For "C21: Low MF," set 1.0000 at first temporarily.

4.1.2 Zero adjustment



Before allowing the fluid to flow, see the user's manual for AXFA11 and perform the automatic zero adjustment.

4.1.3 Measuring flow and calculating the meter factor

Allow the fluid to flow and calculate the new meter factor as follows:

$$\text{New meter factor} = \text{old meter factor} \times \frac{\text{Indicated value of AXFA11}}{\text{Volumetric standard (or indicated value of the master meter)}}$$

Use 1.0000, which was temporarily set to the old meter factor, to calculate the new meter factor. After setting the new meter factor, confirm that the flow indication is correct. If the flow indication is not correct, repeat the above procedure and incorporate the new meter factor.

4.2 How to Obtain Meter Factor by Incorporating the Indicated Flow Rate of the Existing Converter.

This method can be used if an existing flowtube operates properly. In addition, the method requires that the flow rate is constant and stable. In case of this method, the accuracy for reference cannot be provided as it depends on the accuracy of the measuring flow system. As a rule, calibration should be performed by Yokogawa service personnel.

Electrical connection:

Connect an existing flowtube and an existing converter as shown in the figure below:

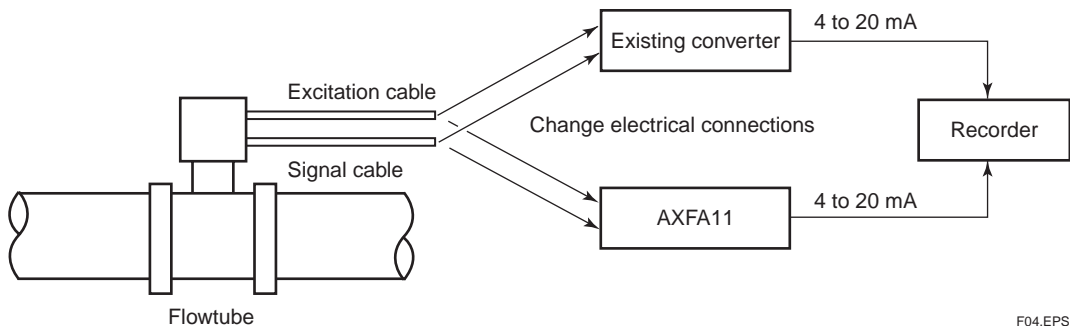

F04.EPS

4.2.1 Parameter setting

Set the size and span to AXFA11. The span shall be the same as the one for the existing converter. In addition, set the parameters according to any combination with relevant models in Chapter 2. For "C21: Low MF," set 1.0000 at first temporarily.

4.2.2 Zero adjustment

Before allowing the fluid to flow, see the user's manual for AXFA11 and perform the automatic zero adjustment. Also apply the zero adjustment to the existing converter.

4.2.3 Measuring flow with existing converter

Measure an instantaneous flow rate in the combination with the existing converter and record the 4 to 20 mA output. Since the indication of AXFA11 at the same flow rate is checked in the next step, do not change the flow rate.

4.2.4 Measuring flow with AXFA11 converter

Change the connections of the existing flowtube to AXFA11 and record the 4 to 20 mA output in the same manner.

4.2.5 Calculating the meter factor

Use the indicated value of the existing converter and the indicated value of AXFA11, which were recorded in the above step, and calculate the new meter factor as follows:

$$\text{New meter factor} = \text{old meter factor} \times \frac{\text{Indicated value of AXFA11 (\%)}}{\text{Indicated value of the existing converter (\%)}}$$

Use 1.0000, which was temporarily set to the old meter factor, to calculate the new meter factor. After setting the new meter factor, confirm that the flow indication is correct. If the flow indication is not correct, repeat the above procedure and incorporate the new meter factor.

4.3 How to Obtain Meter Factor According to the Inferred Flow Rates Such as Valve Openings or Pump Rpm

The accuracy for reference in this case cannot be provided as it depends on the accuracy of the inferred flow rate. As a rule, calibration should be performed by Yokogawa's service personnel.

4.3.1 Parameter setting



Set the size and span to AXFA11. The span shall be 1.5 to 2 times the flow rate. In addition, set necessary parameters according to any combination with relevant models in Chapter 2. For "C21: Low MF," set 1.0000 at first temporarily.

4.3.2 Zero adjustment



Before allowing the fluid to flow, see the user's manual for AXFA11 and perform the automatic zero adjustment.

4.3.3 Measuring flow and calculating the meter factor

Allow the fluid to flow and calculate the new meter factor as follows:

$$\text{New meter factor} = \text{old meter factor} \times \frac{\text{Indicated value of AXFA11}}{\text{Inferred flow rate}}$$

Use 1.0000, which was temporarily set to the old meter factor, to calculate the new meter factor. After setting the new meter factor, confirm that the flow indication is correct. If the flow indication is not correct, repeat the above procedure and incorporate the new meter factor.

5. Compatibility with AXFA11 and AXFA14

If the same AXF flowtube is combined with AXFA11 or AXFA14, meter factors will differ due to differences between the excitation circuit of AXFA11 and that of AXFA14. Therefore, wrong combinations will cause a span error. A span error for reference is approximately 1.5%. Select the correct converter for combination using the flowtube's model and suffix code when ordering.

Since AXFA14 does not have a parameter for setting the excitation current value or switching to the pulsed DC calculation, AXFA14 cannot operate SE, YM and flowtubes of other manufactures. AXFA14 can only operate AXF, AM and AE flowtubes.

On the other hand, as AXFA11 has a parameter "C30:Select Flow tube" for setting the excitation current value or switching to the pulsed DC calculation, AXFA11 can operate other flowtubes including SE and YM.

Compatibility errors for AXFA11 and AXFA14 if flow calibration is not redone (values for reference)

Flowtube \ Converter	AXFA11	AXFA14	AM11	AE14	SE14	YMA11
AXF flowtube for AXFA11 (AXFxxxx-N)	AXF std. performance accuracy	AXF std. accuracy $\pm 1.5\%$	AM std. accuracy $\pm 0.5\%$	AE std. accuracy $\pm 1.5\%$	not available	YM std. accuracy $\pm 2\%$ when calculated MF is used.
AXF flowtube for AXFA14 (AXFxxxx-P)	AXF std. accuracy $\pm 1.5\%$	AXF std. performance accuracy	AM std. accuracy $\pm 1.5\%$	AE std. accuracy $\pm 0.5\%$	not available	not available unless redoing flow calibration
AM flowtube	AM std. accuracy $\pm 0.5\%$	AM std. accuracy $\pm 1.5\%$	AM std. performance accuracy	AE std. accuracy $\pm 1.5\%$ (in principle, not available)	not available	See TI 1E6C1-01E
AE flowtube	AE std. accuracy $\pm 1.5\%$	AE std. accuracy $\pm 0.5\%$	AE std. accuracy $\pm 1.5\%$	AE std. performance accuracy	not available	not available
SE flowtube	not available unless redoing flow calibration	not available	not available	not available	SE std. performance accuracy	not available
YM flowtube	YM std. accuracy $\pm 1\%$ when calculated MF is used	not available	See TI 1E6C1-01E	not available	not available	YM std. performance accuracy

T07.EPS

Appendix. 1 Electrical Connection



CAUTION

1. Disconnect ac power the magmeter flowtube.
Flowtube will be powered by the Yokogawa converter.
 2. Follow the proper Yokogawa wiring procedure for the make and model of magnetic flowtube being converted. failure to follow the proper wiring procedure will result in damage to the Yokogawa converter.
-

(1) Combination AXFA11 and FOXBORO 1800 Series

● AXFA11 Wiring Connections

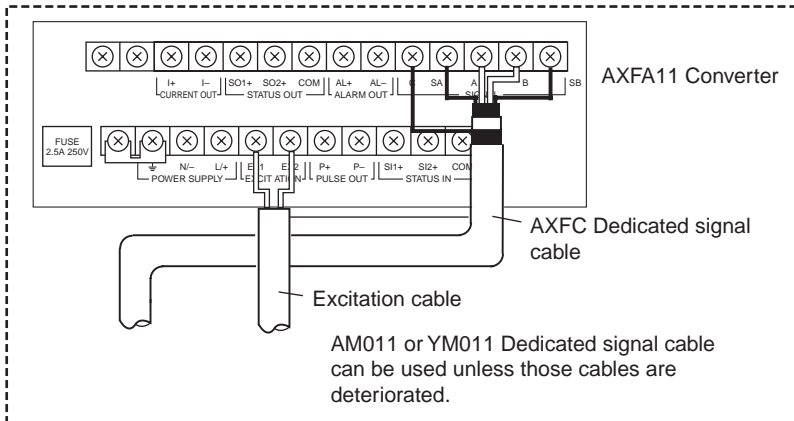

Terminal correspondences

Converter AXFA11	Flowtube 1800 Series
SA *1	Taped
SB *1	Taped
A	B
B	W
C	SH
EX1 *2	L1
EX2 *2	L2

- *1 When a shield drive is not carried out, SA and SB marked are not used.
- *2 If we read negative output, exchange EX1 and EX2 at AXFA11 terminal.
- *3 Exciting power coils must be isolated from ground and other all terminals.

● FOXBORO 1800 Wiring

Sample A

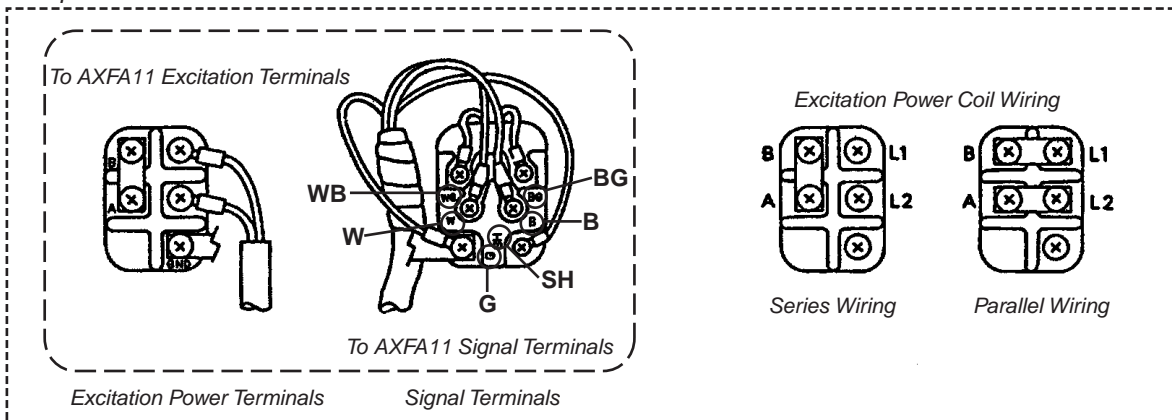

Sample B

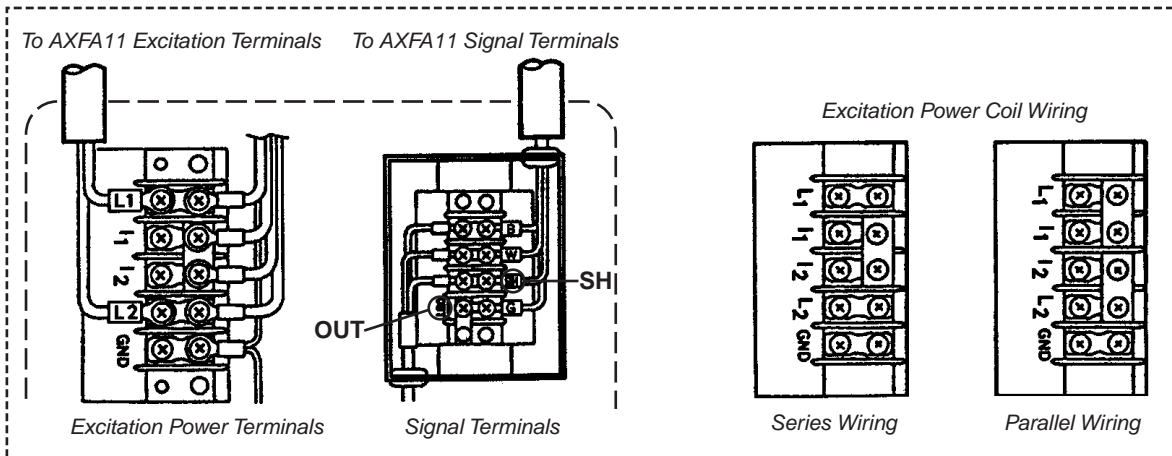

AF02.EPS

FOXBORO 1800 Series Meter Factor List

Following are model numbers, Exciting current values and approximate meter factors for flowtubes where the coils are wired either in series or parallel.

Nominal Size		Series Connection	Parallel Connection
mm	inch	LOW MF (C21)	LOW MF (C21)
15	0.5	0.4483	0.2241
25	1	0.4852	0.2426
40	1.5	0.5852	0.2926
50	2	0.5518	0.2765
80	3	0.6150	0.3075
100	4	0.4609	0.2304
150	6	0.4167	0.2083
200	8	0.3500	0.1705
250	10	0.3990	0.1995
300	12	0.2727	0.1363
350	14	0.3274	0.1316
400	16	0.6373	0.3183

For FOXBORO 1800 Series

AF03.EPS

(2) Combination AXFA11 and FOXBORO 2800 Series

● AXFA11 Wiring Connections

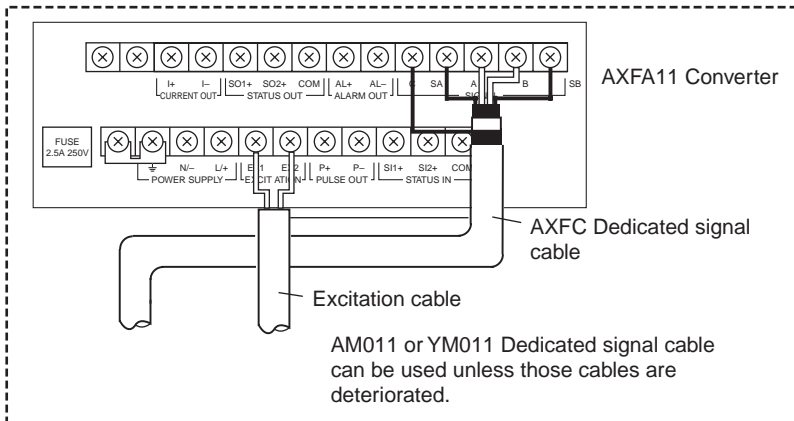

Terminal correspondences

Converter AXFA11	Flowmeter 2800 Series
SA	BG
SB	WG
A	B
B	W
C	SH
EX1 *	L1
EX2 *	L2

* If we read negative output, exchange EX1 and EX2 at AXFA11 terminals.

● FOXBORO 2800 Wiring

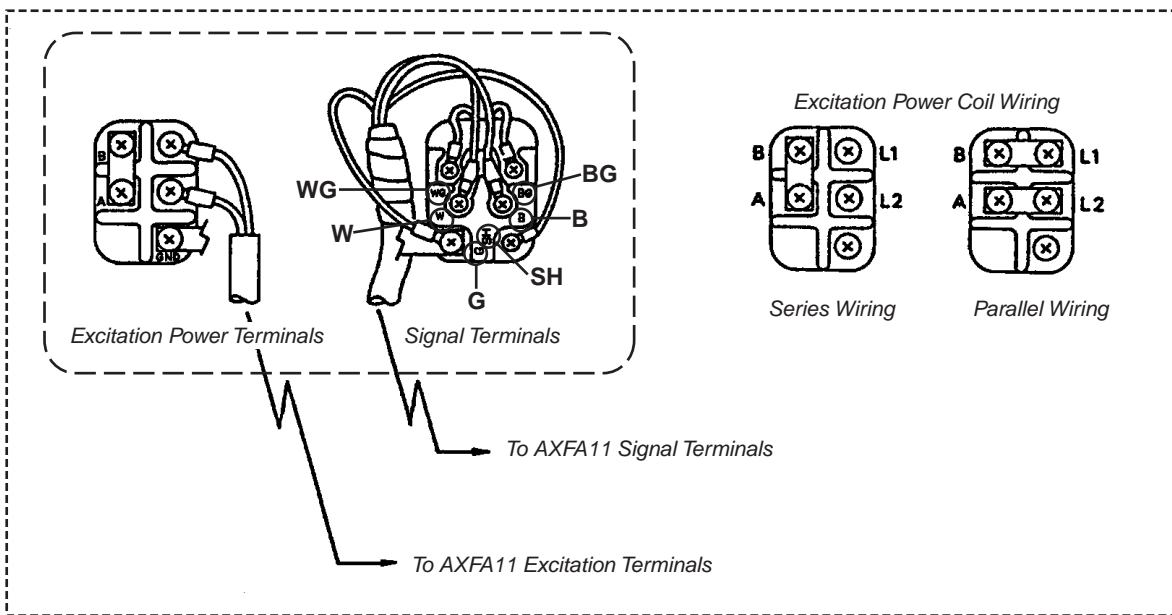

AF04.EPS

FOXBORO 2800 Series Meter Factor List

Following are model numbers, Excitation current values and approximate meter factors for flowtubes where the coils are wired either in series or parallel.

Model	Liner	Nominal Size		Series Connection	Parallel Connection
		mm	inch	LOW MF (C21)	LOW MF (C21)
2891	TF	2.5	0.1	0.2229	—
2893	TF	5.1	0.2	0.2922	—
2893	TF	9.5	0.375	0.4280	—
280H	TF	15	0.5	0.4854	0.2426
2801	TF	25	1	0.5767	0.2883
2801	TT	25	1	0.9939	0.4649
281H	TF	40	1.5	0.7500	0.3750
281H	TT	40	1.5	1.0690	0.5374
2802	TF	50	2	0.7630	0.3814
2802	TT	50	2	0.9852	0.4925
2802	CR	50	2	0.8593	0.4296
2802	UL	50	2	1.0370	0.5185
2803	TF	80	3	0.8992	0.4496
2803	TT	80	3	1.0310	0.5115
2803	CR	80	3	0.9612	0.4806
2803	UL	80	3	1.1630	0.5813
2804	TF	100	4	0.7823	0.3911
2804	TT	100	4	0.8686	0.4342
2804	CR	100	4	0.7823	0.3911
2804	UL	100	4	0.9921	0.4960
2806	TF	150	6	0.5139	0.2569
2806	TT	150	6	0.5421	0.2710
2806	CR	150	6	0.5275	0.2637
2806	UL	150	6	0.6045	0.3022
2808	TF	200	8	0.4269	0.2134
2808	CR	200	8	0.4267	0.2138
2808	UL	200	8	0.4731	0.2365
2810	TF	250	10	0.6316	0.3158
2810	CR	250	10	0.6322	0.3158
2810	UL	250	10	0.6704	0.3352
2812	TF	300	12	0.5018	0.2509
2812	CR	300	12	0.5023	0.2511
2812	UL	300	12	0.5272	0.2635

AF05.EPS

(3) Combination AXFA11 and F&P 10D1418 Series

● AXFA11 Wiring Connections

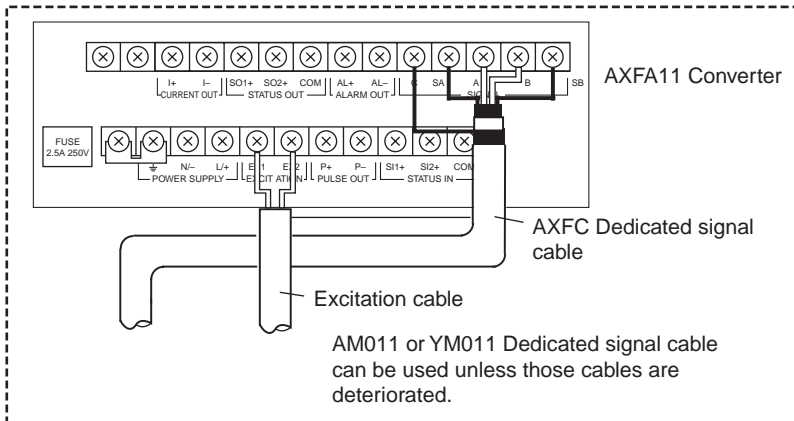

● F&P 10D1418 (Internal Phase) Wiring (1/10" to 4")

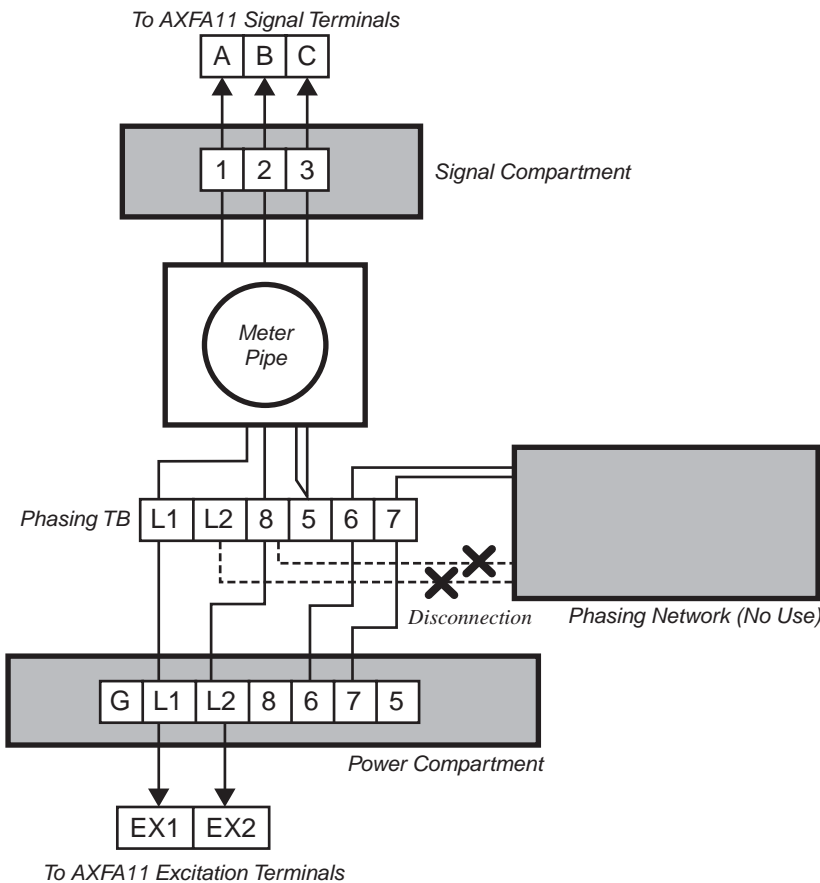

Terminal correspondences (Integral phase)

Converter AXFA11	F&P 10D1418 AC-MAG
SA *1	Taped
SB *2	Taped
A	1
B	2
C	3
EX1 *2	L1
EX2 *2	L2

- *1 When a shield drive is not carried out, SA and SB marked are not used.
- *2 If we read negative output, exchange EX1 and EX2 at AXFA11 terminal.
- *3 Exciting power coils must be isolated from ground and other all terminals.

AF06.EPS

● F&P 10D1418 (Remote Phase) Wiring (1/10" to 4")

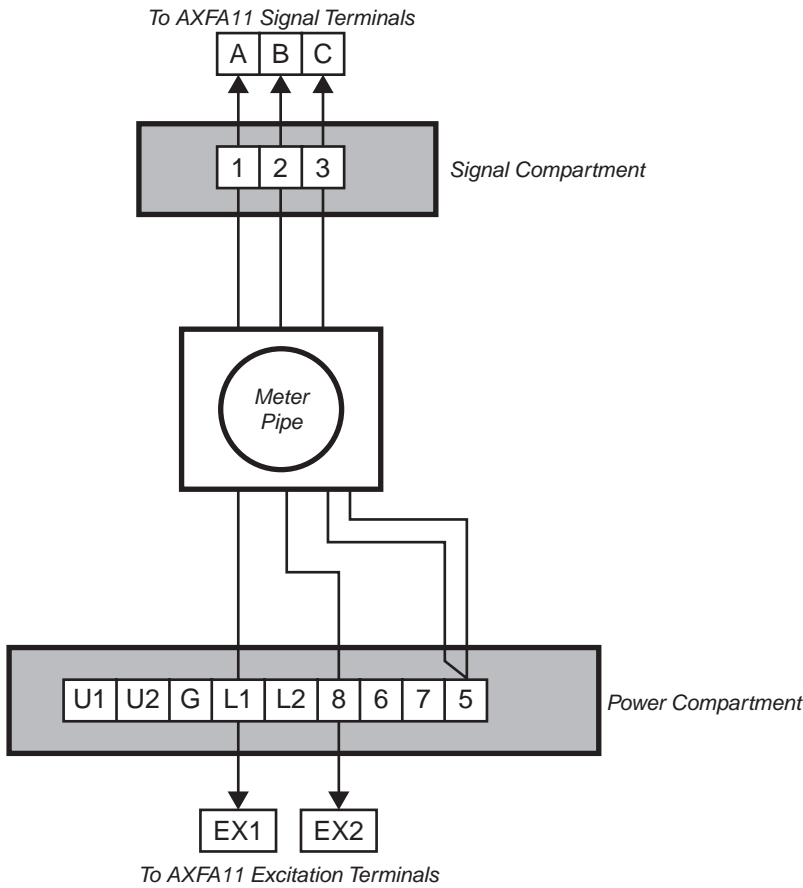

Terminal correspondences (Remote phase)

Converter AXFA11	F&P 10D1418 AC-MAG
SA *1	Taped
SB *2	Taped
A	1
B	2
C	3
EX1 *2	L1
EX2 *2	8

- *1 When a shield drive is not carried out, SA and SB marked are not used.
- *2 If we read negative output, exchange EX1 and EX2 at AXFA11 terminal.
- *3 Exciting power coils must be isolated from ground and other all terminals.

MODIFICATION

- 1) Disconnect AC-Power Supply from flowtube, and connect Excitation Cable from AXFA11 to flowtube Terminal (Power Compartment T B L1, 8)
- 2) Connect Signal Cable from AXFA11 to flowtube. Be sure that No. 3 Terminal of Signal Compartment is definitely grounded to the Mag Body.

AF07.EPS

(4) Combination AXFA11 and F&P 10D1419 Series

● AXFA11 Wiring Connections

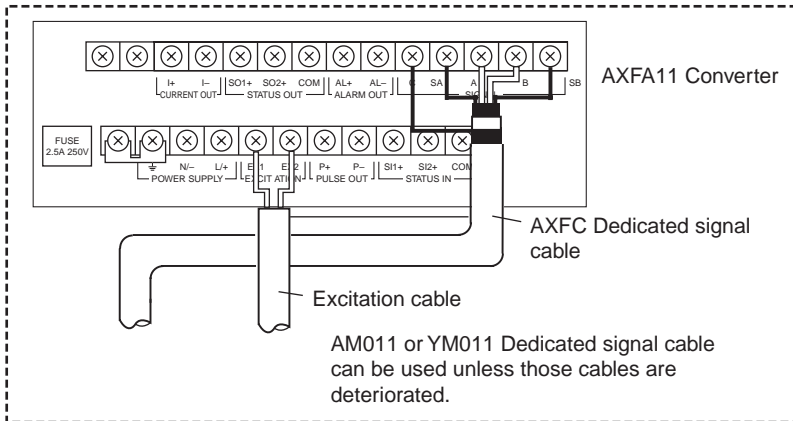

● F&P 10D1419 (Integral) Wiring (1/10" to 4")

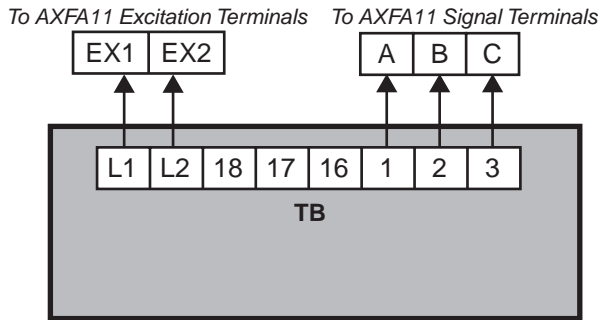

MODIFICATION

Disconnect L1, L2, M1, M2 of magnet driver ass'y. Connect L1 and M1 at air, also connect L2 and M2 at air. (Do not Connect these wires at terminals)

Terminal correspondences

Converter AXFA11	F&P 10D1419 AC-MAG
SA *1	Taped
SB *1	Taped
A	1
B	2
C	3
EX1 *2	L1
EX2 *2	L2

- *1 When a shield drive is not carried out, SA and SB marked are not used.
- *2 If we read negative output, exchange EX1 and EX2 at AXFA11 terminal.
- *3 Exciting power coils must be isolated from ground and other all terminals.

● F&P 10D1419 (Remote Type) Wiring

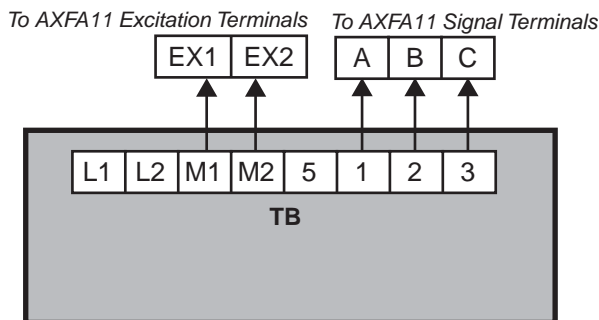

Terminal correspondences

Converter AXFA11	F&P 10D1419 AC-MAG
SA *1	Taped
SB *1	Taped
A	1
B	2
C	3
EX1 *2	M1
EX2 *2	M2

- *1 When a shield drive is not carried out, SA and SB marked are not used.
- *2 If we read negative output, exchange EX1 and EX2 at AXFA11 terminal.
- *3 Exciting power coils must be isolated from ground and other all terminals.

AF08.EPS

(5) Combination AXFA11 and F&P 10D1430 Series

● AXFA11 Wiring Connections

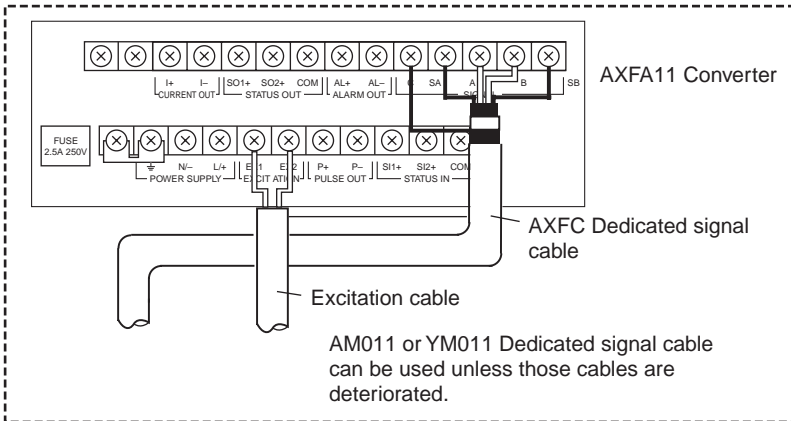

● F&P 10D1430 (Integral Phasing Type) Wiring

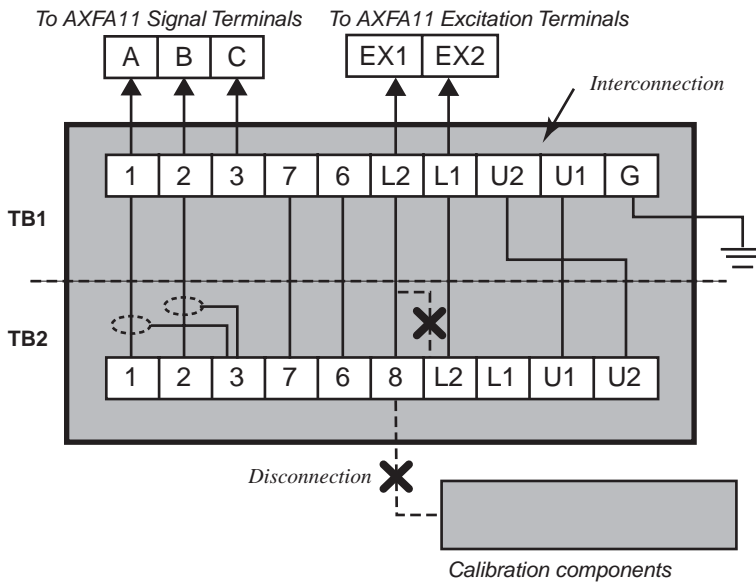

Terminal correspondences

Converter AXFA11	F&P 10D1430
SA *1	Taped
SB *1	Taped
A	1
B	2
C	3
EX1 *2	L1
EX2 *2	L2

*1 When a shield drive is not carried out, SA and SB marked are not used.

*2 If we read negative output, exchange EX1 and EX2 at AXFA11 terminal.

*3 Exciting power coils must be isolated from ground and other all terminals.

MODIFICATION

- 1) Remove L2 at TB2 (FM TB) and connect No. 8 terminal of TB2.
- 2) Disconnect No. 8 terminal of TB2 (Wire from calibration components) and tape it.

AF09.EPS

● F&P 10D1430 (Remote Cali. Type) Wiring

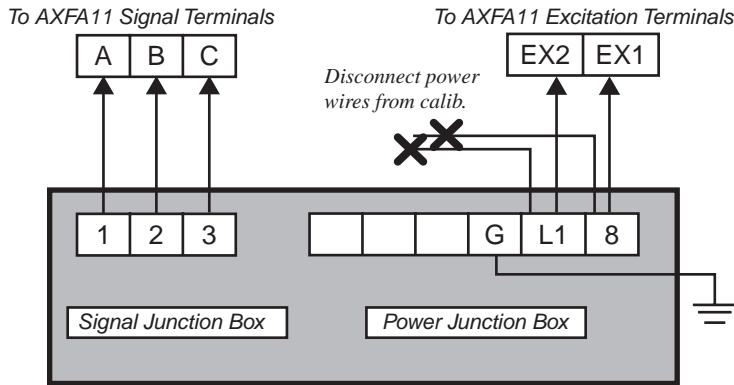

Terminal correspondences

Converter AXFA11	F&P 10D1430
SA *1	Taped
SB *1	Taped
A	1
B	2
C	3
EX1 *2	L1
EX2 *2	8

- *1 When a shield drive is not carried out, SA and SB marked are not used.
- *2 If we read negative output, exchange EX1 and EX2 at AXFA11 terminal.
- *3 Exciting power coils must be isolated from ground and other all terminals.

MODIFICATION

- 1) Disconnect power wires L1, 8 at Power junction box, and connect AXFA11's excitation cable to these L1, 8 terminal.

● F&P 10D1430 (Submersible Type) Wiring

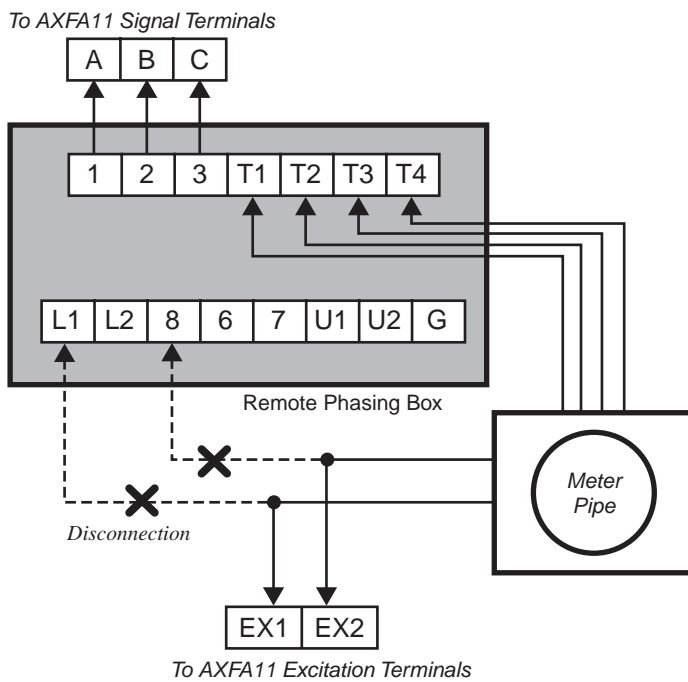

Terminal correspondences

Converter AXFA11	F&P 10D1430
SA *1	Taped
SB *1	Taped
A	1
B	2
C	3
EX1 *2	L1
EX2 *2	8

- *1 When a shield drive is not carried out, SA and SB marked are not used.
- *2 If we read negative output, exchange EX1 and EX2 at AXFA11 terminal.
- *3 Exciting power coils must be isolated from ground and other all terminals.

MODIFICATION

- 1) Disconnect power wires L1, 8 at remote box, and connect AXFA11's excitation cable to L1, 8 air.

AF10.EPS

(6) Combination AXFA11 and F&P 10D1435 (MAGX) Series (6" to 48")

● AXFA11 Wiring Connections

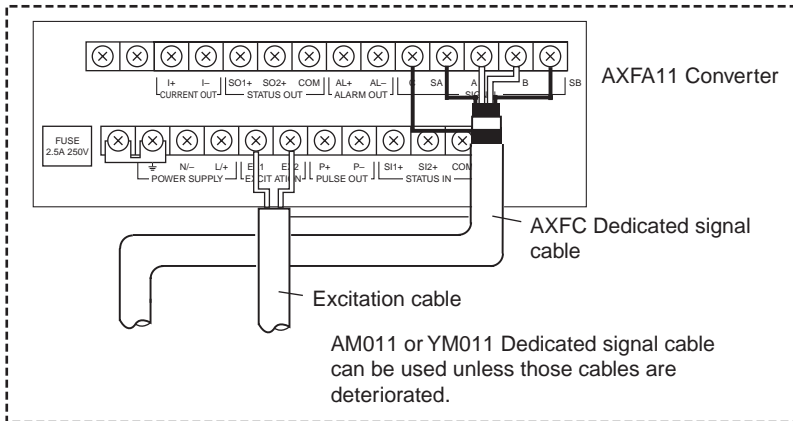

● F&P 10D1435 (Integral Magnet Driver) Wiring

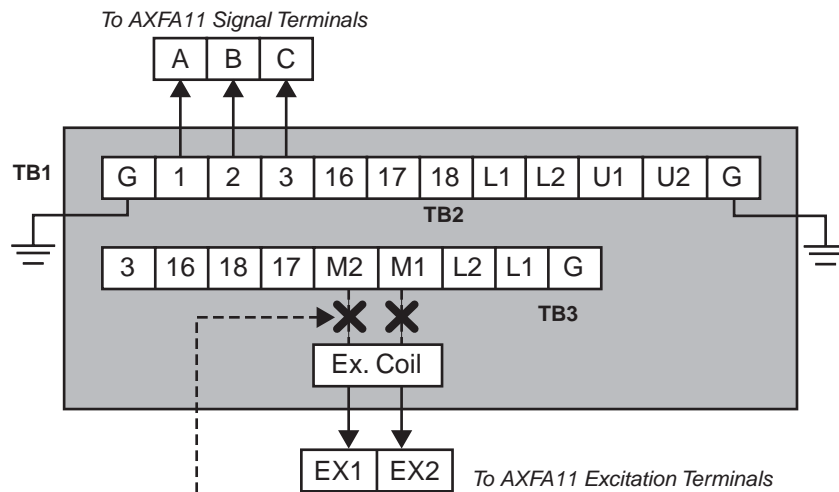

Terminal correspondences

Converter AXFA11	F&P 10D1435 MAGX
SA *1	Taped
SB *1	Taped
A	1
B	2
C	3
EX1 *2	Ex. Coil
EX2 *2	Ex. Coil

- *1 When a shield drive is not carried out, SA and SB marked are not used.
- *2 If we read negative output, exchange EX1 and EX2 at AXFA11 terminal.
- *3 Exciting power coils must be isolated from ground and other all terminals.

MODIFICATION
 Disconnect Ex. Coil Wires from M1, M2 and Connect Ex1 and Ex2 cable from AXFA11 at air.

● F&P 10D1435 (Remote Magnet Driver) Wiring

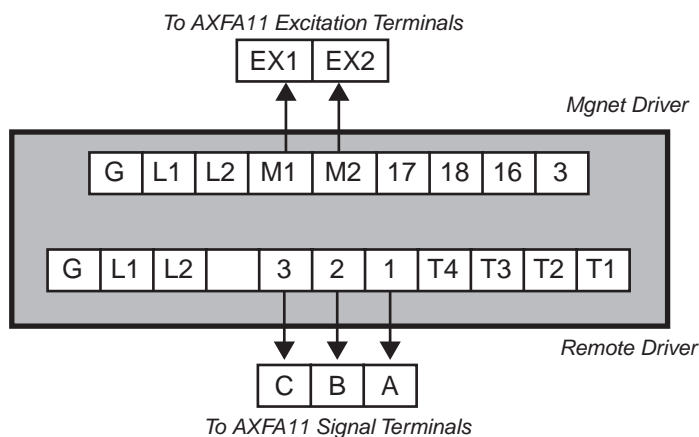

Terminal correspondences

Converter AXFA11	F&P 10D1435 MAGX
SA *1	Taped
SB *1	Taped
A	1
B	2
C	3
EX1 *2	M1
EX2 *2	M2

- *1 When a shield drive is not carried out, SA and SB marked are not used.
- *2 If we read negative output, exchange EX1 and EX2 at AXFA11 terminal.
- *3 Exciting power coils must be isolated from ground and other all terminals.

AF11.EPS

(7) Combination AXFA11 and F&P 10D1475 (MINI MAGX) Series

● AXFA11 Wiring Connections

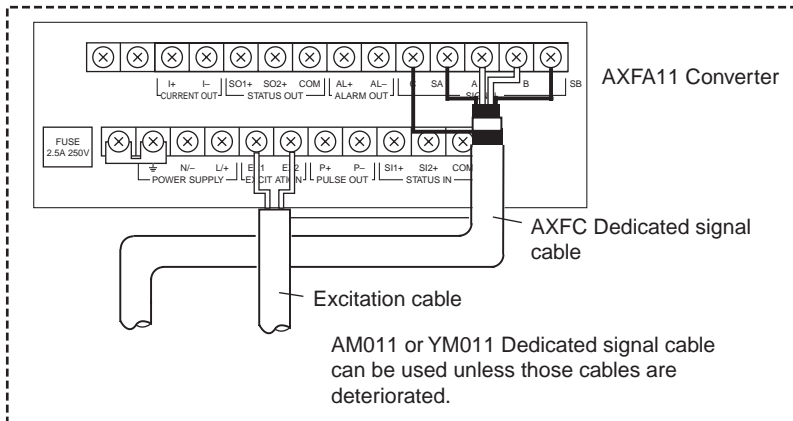

● F&P 10D1475 (Integral Type) Wiring

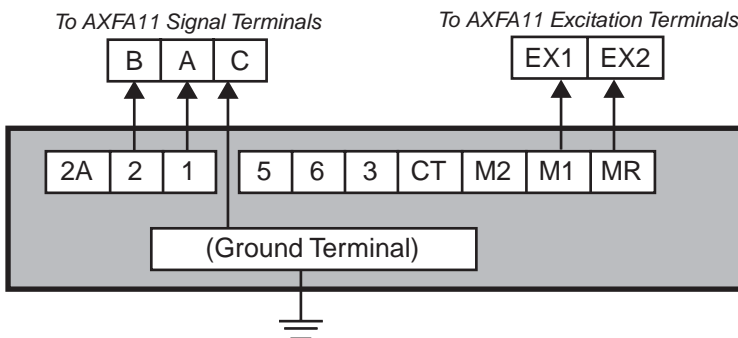

MODIFICATION

1) Disconnect all wires from this terminal except signal and exciting wires as shown.

Terminal correspondences

Converter AXFA11	F&P 10D1475 MINI-MAG
SA *1	Taped
SB *1	Taped
A	1
B	2
C	Ground
EX1 *2	M1
EX2 *2	MR

- *1 When a shield drive is not carried out, SA and SB marked are not used.
- *2 If we read negative output, exchange EX1 and EX2 at AXFA11 terminal.
- *3 Exciting power coils must be isolated from ground and other all terminals.

● F&P 10D1475C (Remote Type) Wiring

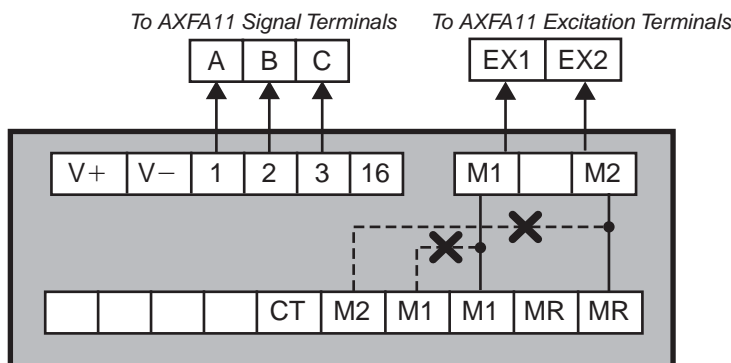

MODIFICATION

1) Disconnect M1, M2 of primary board and connect another M1, MR.

Terminal correspondences

Converter AXFA11	F&P 10D1475 MINI-MAG
SA *1	Taped
SB *1	Taped
A	1
B	2
C	3
EX1 *2	M1
EX2 *2	M2

- *1 When a shield drive is not carried out, SA and SB marked are not used.
- *2 If we read negative output, exchange EX1 and EX2 at AXFA11 terminal.
- *3 Exciting power coils must be isolated from ground and other all terminals.

(8) Combination AXFA11 and BROOKS 7000 Series

● AXFA11 Wiring Connections

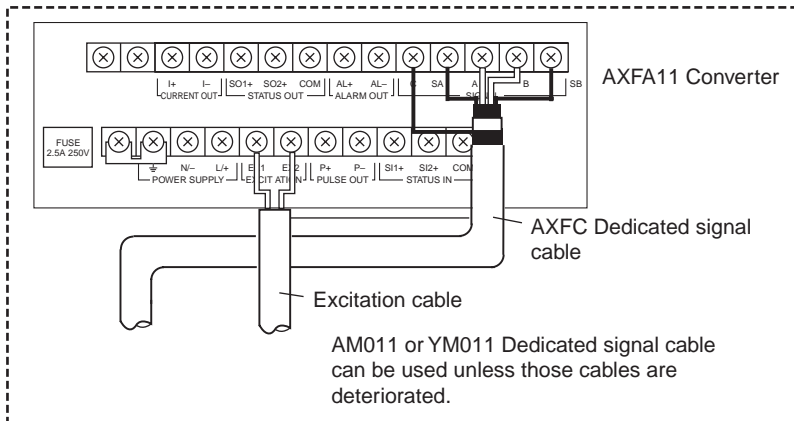

● BROOKS 7000 Wiring

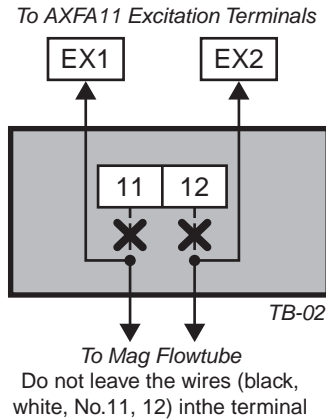
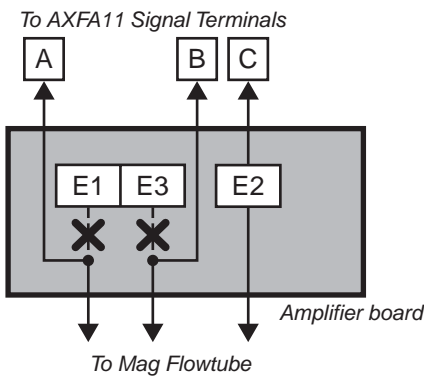

Terminal correspondences

Converter AXFA11	BROOKS 7000 Series
SA *1	Taped
SB *1	Taped
A	E1 of AMP.
B	E3 of AMP.
C	E2 of AMP.
EX1 *2	11 of TB-02.
EX2 *2	12 of TB-02.

- *1 When a shield drive is not carried out, SA and SB marked are not used.
- *2 If we read negative output, exchange EX1 and EX2 at AXFA11 terminal.
- *3 Exciting power coils must be isolated from ground and other all terminals.

MODIFICATION

- 1) Disconnect power supply at L1 DG TB4-AC power and J2, J5 in Mag flowtube. (No power supply needs to Brooks Mag)
- 2) Remove wires of TB-11 and 12 in power supply board and connect EX1, EX2 (AXFA11) to these wires as follows:

EX1 EX2=Excitation Power from AXFA11	AXFA11	7000 TB-02	Do not connect these wires at terminals, connect at air
	EX1	11	
	EX2	12	

- 3) Remove E1, E2, E3 of amplifier board and connect A, B and C

EX1 EX2=Signal terminal from AXFA11	AXFA11	7000 TB-02	Do not connect these wires at terminals, connect at air
	A	E1	
	B	E3	
	C	E2	

(9) Combination AXFA11 and BROOKS 7100 Series

● AXFA11 Wiring Connections

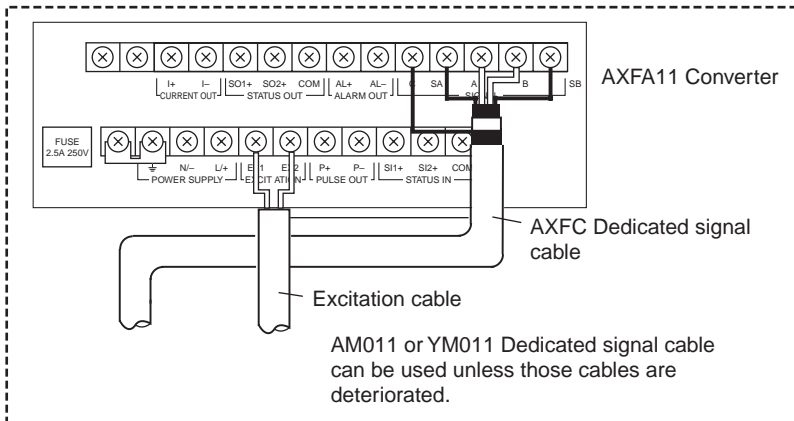

● BROOKS 7100 Wiring

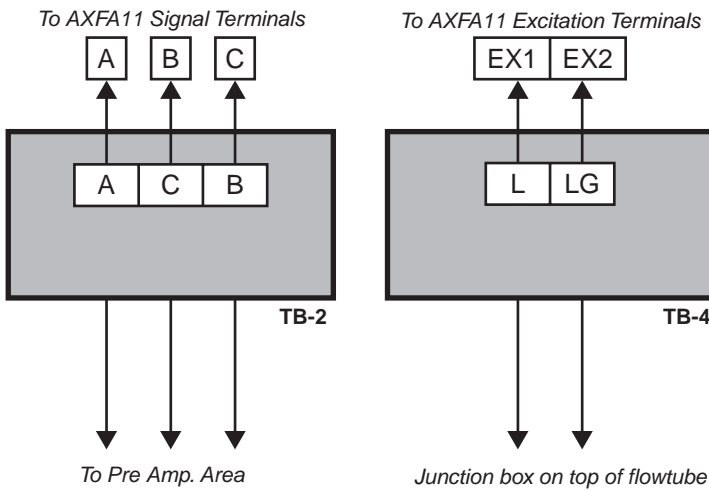

Terminal correspondences

Converter AXFA11	BROOKS 7100 Series AC-MAG
SA *1	Taped
SB *1	Taped
A	A (TB2)
B	C (TB2)
C	B (TB2)
EX1 *2	L (TB4)
EX2 *2	LG (TB4)

*1 When a shield drive is not carried out, SA and SB marked are not used.
 *2 If we read negative output, exchange EX1 and EX2 at AXFA11 terminal.
 *3 Exciting power coils must be isolated from ground and other all terminals.

AF14.EPS

(10) Combination AXFA11 and BROOKS 7400 Series

● AXFA11 Wiring Connections

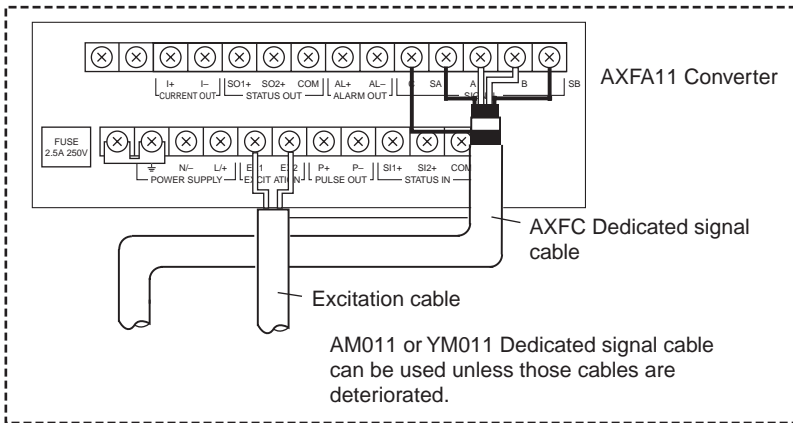

● BROOKS 7400 Wiring

To AXFA11 Signal Terminals

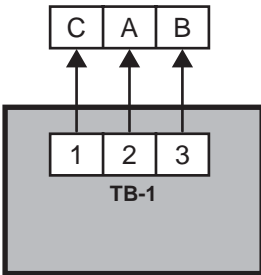

To AXFA11 Excitation Terminals

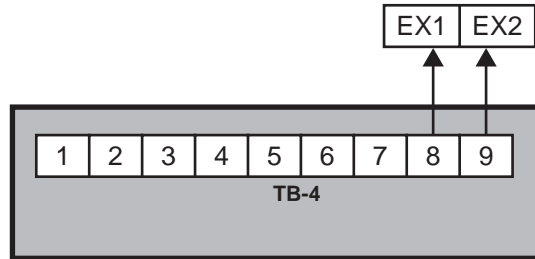

Terminal correspondences

Converter AXFA11	BROOKS 7400 Series Wafer-MAG
SA *1	Taped
SB *1	Taped
A	2 (TB1)
B	3 (TB1)
C	1 (TB1)
EX1 *2	8 (TB2)
EX2 *2	9 (TB2)

- *1 When a shield drive is not carried out, SA and SB marked are not used.
- *2 If we read negative output, exchange EX1 and EX2 at AXFA11 terminal.
- *3 Exciting power coils must be isolated from ground and other all terminals.

Brooks 7400 Wafer Mag

It is necessary to modify following terminal and connectors.

- 1) Signal Cable Connector J1
- 2) Field Coil Connector J3
- 3) Customer Hook-up TB1, TB2

How to Modify BROOKS 7400 Wafer Mag

- 1) Open Electronic Box Cover.
- 2) Remove whole electronics from electronics box.
- 3) Disconnect all wires from TB1, TB2, except No. One Terminal of TB1.
- 4) Modification of J3 (Field Coil)
 - Connect No.2, No.5 wires of J3 Connector (Field Coil Connector) to Terminal 8, 9 of TB2.
 - Connect No.1, No.6 wires of J3 at air. (To make a closed loop of an excitation circuit)
- 5) J1 (Signal Cable)
 - Connect No.2, No.3 wires at air.
 - Also connect No.4, No.1 wires to No.2 and No.3 Terminal of TB1.
- 6) Connect cables from AXFA11 to Wafer-Mag customer hook-up.

AF15.EPS

(11) Combination AXFA11 and BROOKS 7500 Series

● AXFA11 Wiring Connections

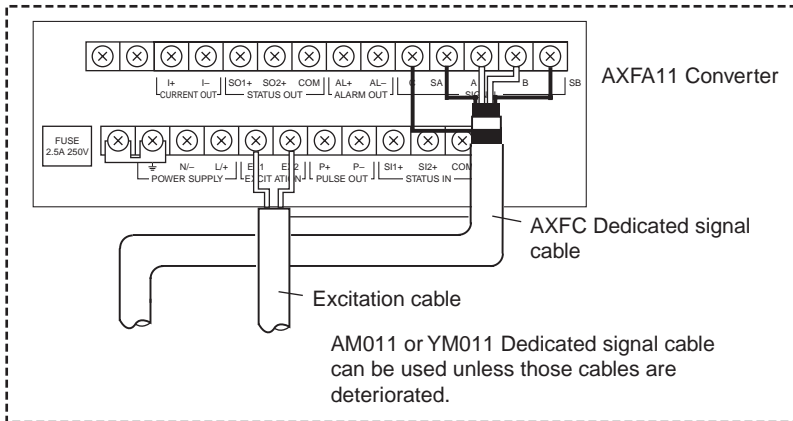

● BROOKS 7500 Wiring

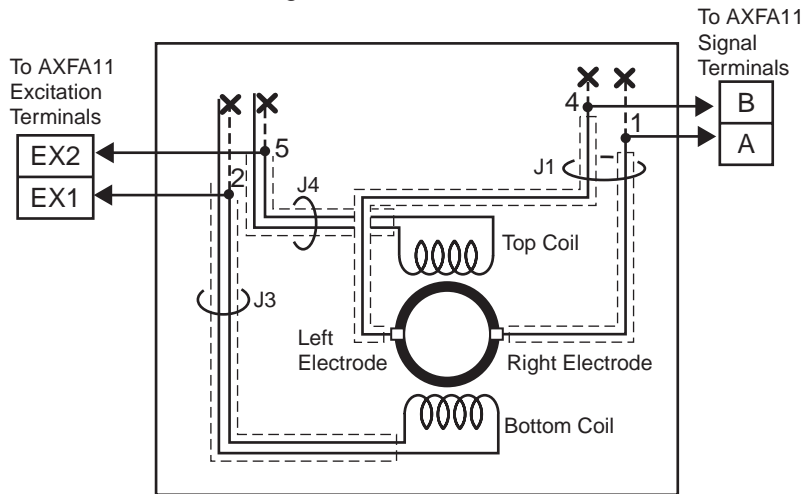

Terminal correspondences

Converter AXFA11	BROOKS 7500 Series
SA *1	Taped
SB *1	Taped
A	1 of J1
B	4 of J1
C	System Com
EX1 *2	2 of J3
EX2 *2	5 of J3

- *1 When a shield drive is not carried out, SA and SB marked are not used.
- *2 If we read negative output, exchange EX1 and EX2 at AXFA11 terminal.
- *3 Exciting power coils must be isolated from ground and other all terminals.

How to Combination AXFA11 and BROOKS 7500

- Power disconnection of flowtube
Disconnect power supply (L, N) at TB1 in customer hook-up. (No power supply needs to BROOKS 7500 Mag.)
- Excitation power from AXFA11 to flowtube.
Cut wires of connector J3 (Female side) on power supply coil drive.
Connect EX1, EX2 (From AXFA11) to these wires as follows:

AXFA11	7500 J3/Power Coil Drive
EX1	2
EX2	5

Do not connect these wires at terminals, connect at air

- Signal wiring to AXFA11
Cut wires of connector (J1, Female) on signal conditioner.
Connect A, B and C to these wires as follows:

AXFA11	7500 J3/Power Coil Drive
A	1
B	4
C	System Com. at signal Cond. (2, 3) Maile side

Do not connect these wires at terminals, connect at air

(12) Combination AXFA11 and KROHNE ALTFLUX X-1000, M900 Series

● AXFA11 Wiring Connections

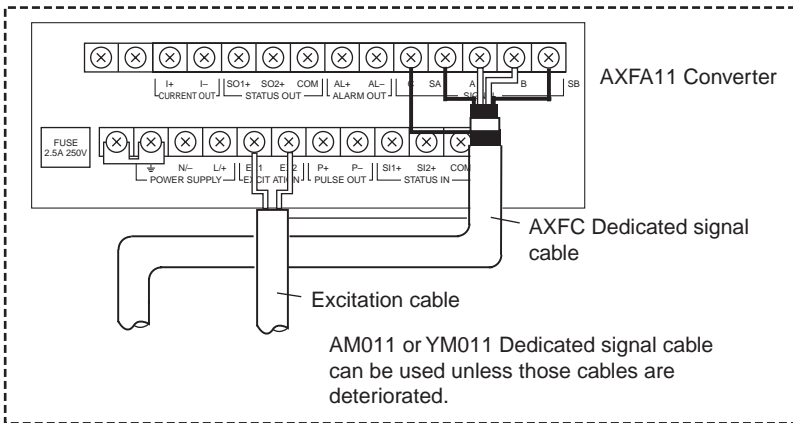

● X-1000, M900 Series (Using Signal Cable Type A) Wiring

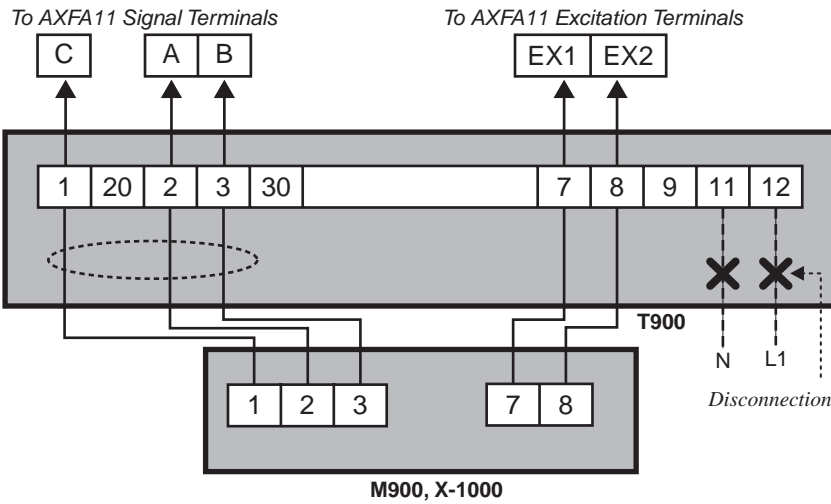

Terminal correspondences

Converter AXFA11	KROHNE ALTFLUX
SA *1	Taped
SB *1	Taped
A	2
B	3
C	1
EX1 *2	7
EX2 *2	8

*1 When a shield drive is not carried out, SA and SB marked are not used.

*2 If we read negative output, exchange EX1 and EX2 at AXFA11 terminal.

*3 Exciting power coils must be isolated from ground and other all terminals.

● X-1000, M900 Series (Using Signal Cable Type B) Wiring

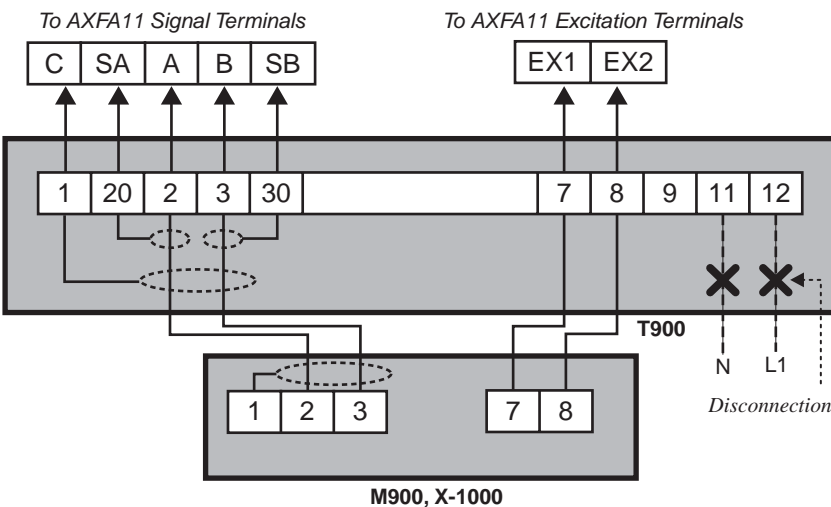

Terminal correspondences

Converter AXFA11	KROHNE ALTFLUX
SA *1	20
SB *1	30
A	2
B	3
C	1
EX1	7
EX2	8

*1 When a shield drive is not carried out, SA and SB marked are not used.

How to Combination AXFA11 and KROHNE ALTFLUX X-1000, ALTFLUX MT900 Series

1. Signal Wiring from Flowtube to AXFA11

Disconnect all signal wires from T900F signal terminals (No.1, 20, 2, 3, 30).
Connect these wires to AXFA11 signal terminals as below. Please do not connect these wires at T900F signal terminals; but, connect at AXFA11 signal terminals.

AXFA11 Signal terminals	X-1000 / M900 Signal Wires
A	2 (Common)
B	3 (Common)
C	1 (Common)
SA	Shield for 20
SB	Shield for 30

AF18-1.EPS

2. Excitation Power from AXFA11 to Flowtube

Disconnect wires from terminals No. 7, 8 of T900F.
Connect wires to EX1, EX2 or AXFA11 as shown below.

AXFA11	X-1000 / M900
EX1	7
EX2	8

AF18-2.EPS

If we need a negative output, exchange EX1 and EX2.

(13) Combination AXFA11 and ROSEMOUNT 8701

● AXFA11 Wiring Connections

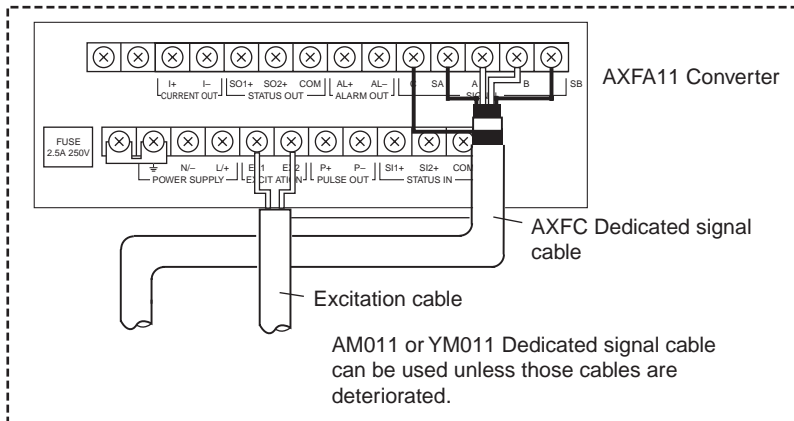

● Model 8701 Wiring

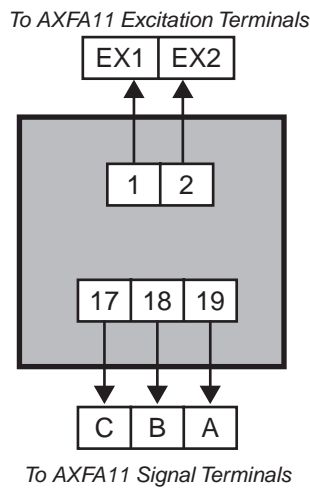

Terminal correspondences

Converter AXFA11	ROSEMOUNT 8701
SA *1	Taped
SB *1	Taped
A	19
B	18
C	17
EX1 *2	1
EX2 *2	2

- *1 When a shield drive is not carried out, SA and SB marked are not used.
- *2 If we read negative output, exchange EX1 and EX2 at AXFA11 terminal.
- *3 Exciting power coils must be isolated from ground and other all terminals.

AF19.EPS

(14) Combination AXFA11 and TAYLOR 1100 Series

● AXFA11 Wiring Connections

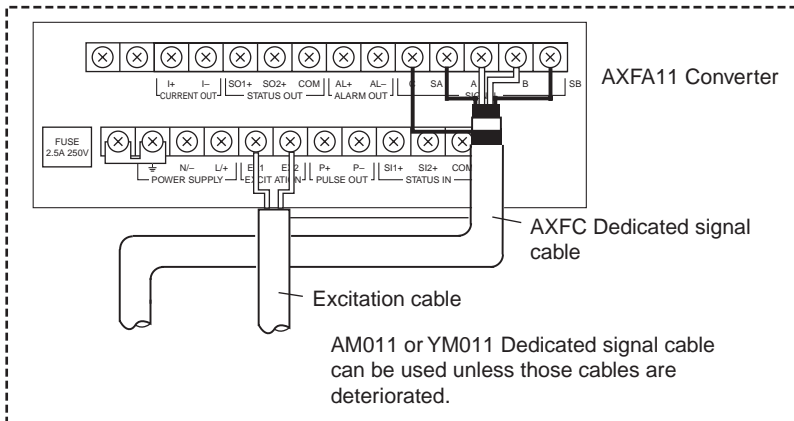

● TAYLOR 1100 (0.1", 0.2", 0.36", 0.5") Wiring

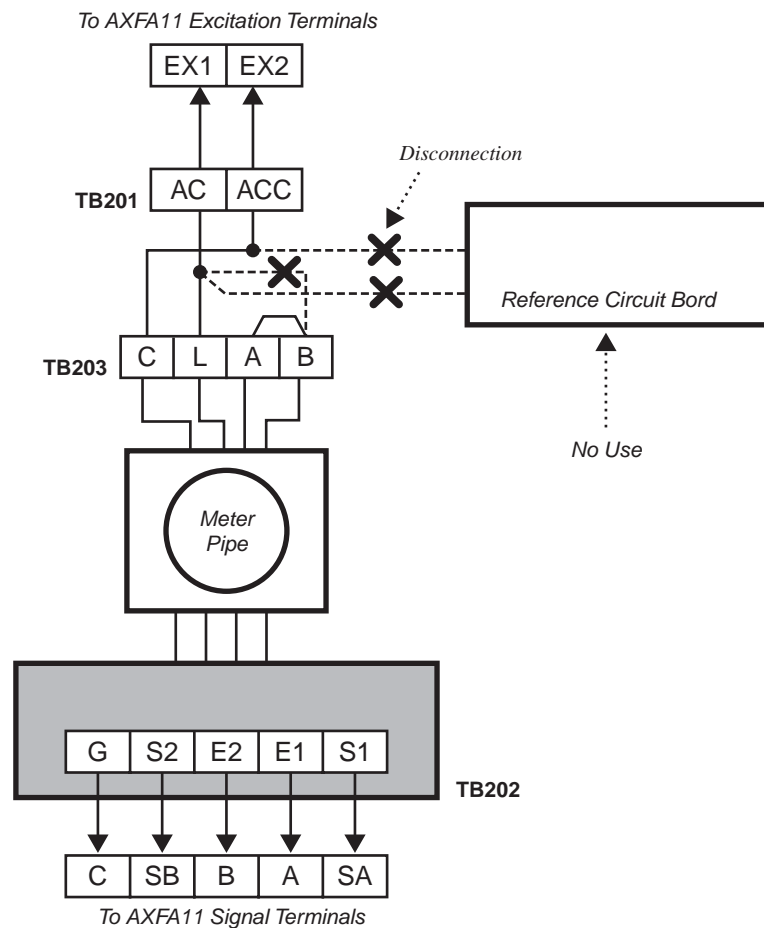

Terminal correspondences

Converter AXFA11	TAYLOR 1100 Series
SA *1	(S1)
SB *1	(S2)
A	E1
B	E2
C	GND
EX1 *2	AC
EX2 *2	ACC

- *1 When a shield drive is not carried out, SA and SB marked are not used.
- *2 If we read negative output, exchange EX1 and EX2 at AXFA11 terminal.
- *3 Exciting power coils must be isolated from ground and other all terminals.
- *4 Make sure "GND" terminal of TB202 must be grounded to the body.

AF20.EPS

Size 0.1", 0.2", 0.36", 0.5" Flowtube

- 1) Open Electronic Box Cover.
- 2) Remove all cables from Flowtube except Signal Cable. (The cables are not needed anymore.)
Reference circuit and its terminal are no longer used.
- 3) Disconnect the BRN wire (which connects the T202-reference circuit to "L" Terminal of TB203 and tape it.
- 4) Relocate the RED wire (from "AC" Terminal of TB201 to "R" Terminal of TB203) to "L" Terminal of TB203.
- 5) Connect excitation cable from AXFA11 excitation terminal to "AC" and "ACC" Terminal of TB201.
- 6) Signal Cable Connection:
Confirm GND (GRN) Terminal of TB202 is properly grounded to Mag Body.
Connect Signal cable to AXFA11.
- 7) Reference Meter Factor.
Around 0.1 thru 0.4

● TAYLOR 1100 (1" to 12") Wiring

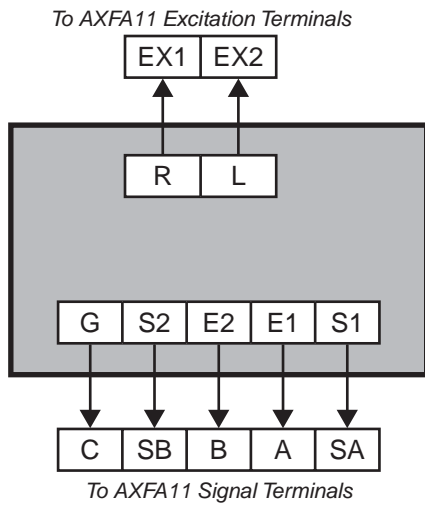

Terminal correspondences

Converter AXFA11	TAYLOR 1100 Series
SA *1	(S1)
SB *1	(S2)
A	E1
B	E2
C	GND
EX1 *2	AC
EX2 *2	ACC

- *1 When a shield drive is not carried out, SA and SB marked are not used.
- *2 If we read negative output, exchange EX1 and EX2 at AXFA11 terminal.
- *3 Exciting power coils must be isolated from ground and other all terminals.
- *4 Make sure "GND" terminal of TB202 must be grounded to the body.

AF22.EPS

Size 1" to 12" Flowtube

- 1) Open Electronic Box Cover.
- 2) Remove all cables from Flowtube except Signal Cable. (The cable are not needed anymore.)
Reference circuit and its terminal are no longer used.
- 3) Disconnect wire of "R" (BLK) Terminal and "L" (BRN) Terminal on TB203 from transform side (not from exciting coil side), and tape them.
- 4) Connect excitation cable from AXFA11 excitation terminals to "R" and "L" Terminal of TB203.
- 5) Signal Cable Connection:
Confirm GND (GRN) Terminal of TB202 is properly grounded to Mag Body. Connect Signal Cable to AXFA11. Terminals S1 and S2 should definitely be isolated from other terminal.

Following are Nominal Size and reference meter factor.

Nominal Size (inch)	Meter Factors
1	0.3000
1.5	0.3500
2	0.3750
3	0.4000
4	0.3500
6	0.3000
8	0.2500
10	0.2250
12	0.2000

AF21.EPS

For TAYLOR Mag-Pipe Flowtube (AC Mag) Type 1100L, 1101L.