User's Manual

Model MLA & MLD Loop Powered Process Indicators



Model MLD (Digital)

Model MLA (Analog)

1. PREFACE

The Model MLA and MLD field mounted indicators receive DC voltage or current signals by electronic transmitters and indicate process measurement values. This instruction manual gives instructions on handling, mounting, and wiring of the MLA (analog type) and MLD (digital type) indicators.

2. MODEL CODE AND SPECIFICATIONS

| Model | Suffix Codes | Description |
|---------------------------|--------------|--|
| MLA | | Field Mounted Loop Indicator (Analog) |
| MLD | | Field Mounted Loop Indicator (Digital) |
| Input Signal | -A | 4 to 20 mA DC |
| | -B | 10 to 50 mA DC (MLA only) |
| | -C | 1 to 5 VDC (MLA only) |
| Mounting | 1..... | 2" Horizontal Pipe |
| | 2 | 2" Vertical Pipe (or wall mount) |
| Electrical Classification | /N4X | NEMA4X Enclosure (weatherproof) |
| | /FF1 | FM Explosion Proof |
| | /CF1 | CSA Explosion Proof |
| Options | /ENG | Engineering Unit Calibration (MLD) |
| | /WHT | White scale or face plate |
| | /SC | Scale in Engineering Units (MLA) |
| | /SST | Stainless Steel Tag |

STANDARD SPECIFICATIONS

Input Resistance: < 6.5 ohm (MLA-A 4-20mA), < 13.5 ohm (MLA-B 10-50mA), ~4K ohm (MLA-C 1-5V)

Voltage drop: 1.8V typical, 2V max. (MLD)

Scale: : Black. Analog single graduations 0-100% std. Digital 0-100.0% w/decimal std.

Accuracy: ± 1.5% of full scale (MLA), ± 0.05% of full scale (1999) +1 digit (MLD)

Operating Temperature Range: -20 to 60°C

Temperature drift: ±0.3digit/°C (MLD)

Vibration: 1G @ 10-150Hz (MLA), 3G @ 10-150Hz (MLD)

Insulation Resistance: Between input terminals and case 100 Mohm at 500 V DC

Dielectric Strength: Between input terminals and case: 1000 V AC for 1 minute.

Mounting: Nominal 2" (50mm) pipe mount or surface.

Electrical Classification: NEMA4X, FM, CSA, EXPLOSIONPROOF CL1, DIV1, GPS A,B,C,D, DUST-IGNITIONPROOF CLII / III, GPS E,F,G

Case and Cover: Die cast aluminum, baked polyurethane paint. Dark green. NEMA4X

Electrical Connection: $\frac{1}{2}$ " NPT

Weight: 3.0 lbs (MLA), 2.7 lbs (MLD)

OPTIONS

Scale: MLA: Special range scale in Engineering Units (/SC).

MLD: Custom lasered faceplate available on request.

Scale or Faceplate color: White on request (/WHT)

Scaling: Digital: Special calibration in Engineering Units (/ENG). Max. value = 1999

ORDERING INSTRUCTIONS

1. Model, Suffix, and Option codes.
2. Scale range and unit markings desired.
3. Tag number.

Example Ordering Instructions:

MLA-A1/FF1/SC/SST (Field Mounted Loop Indicator (Analog), 4 to 20 mA DC, 2" Horizontal Pipe, FM Explosion Proof,

0-200 InH2O scale in Engineering Units.) Please specify Scale and Engineering units when ordering /SC.

FT-201 Specify Tag Number when ordering /SST; Up to 8 Characters.

DIMENSIONS

Unit: mm (Approx. inch)

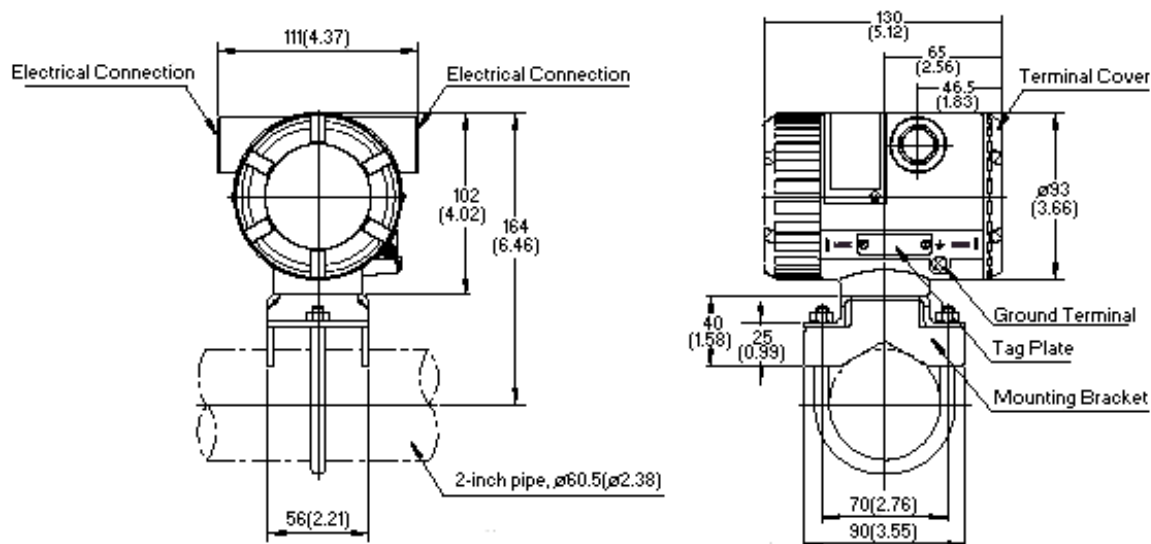

3. INSTALLATION

The Loop Powered Indicator can be mounted on a wall or a 2" pipe. The housing is a Nema4X Explosion Proof housing so it can be mounted outside in the field.

Do not install the unit in the following conditions:

- Extreme Temperatures beyond the temperature rating of the instrument.
- High vibration areas above the vibration rating of the instrument.
- Extremely corrosive environments.

MOUNTING EXAMPLES

Vertical Pipe Mounting

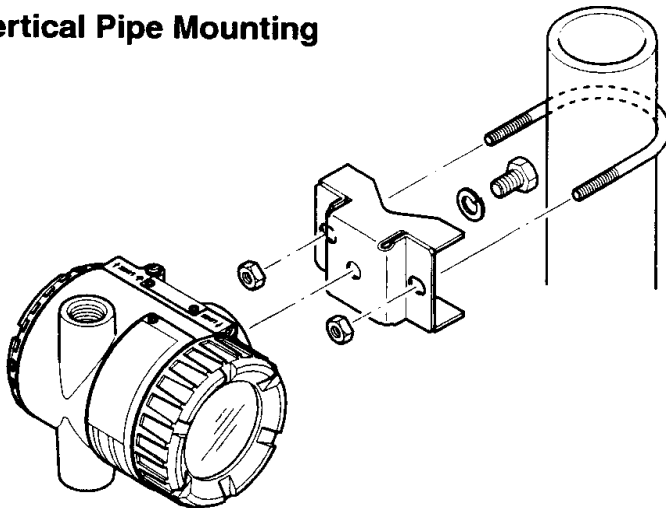

Horizontal Pipe Mounting

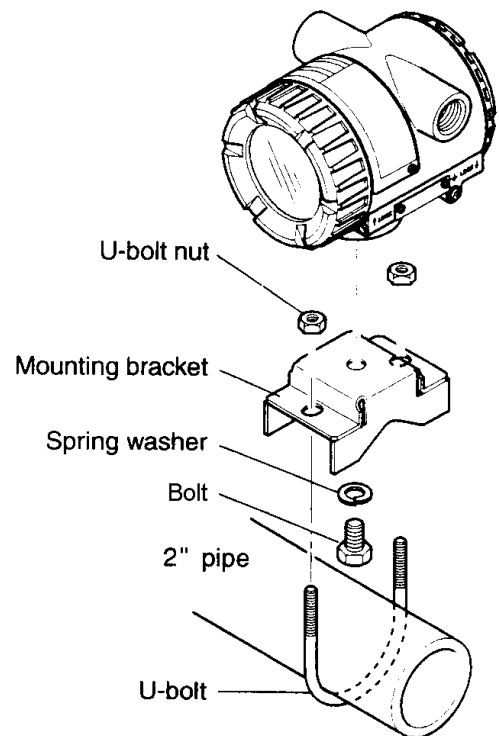

Wall Mounting

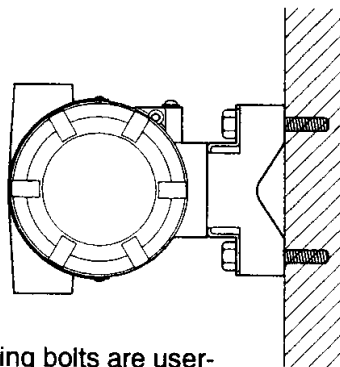

Note: Wall mounting bolts are user-supplied.

4. WIRING

The loop powered indicator series is powered by the current output loop and does not require external power. All devices must be wired in series with the current loop. Twisted pair shielded cable is recommended.

The following is a typical wiring example of the MLA (Analog type) Loop Indicator connected to an EJA Pressure Transmitter. The impedance of the MLA is low enough that you can connect it across the Check Terminals

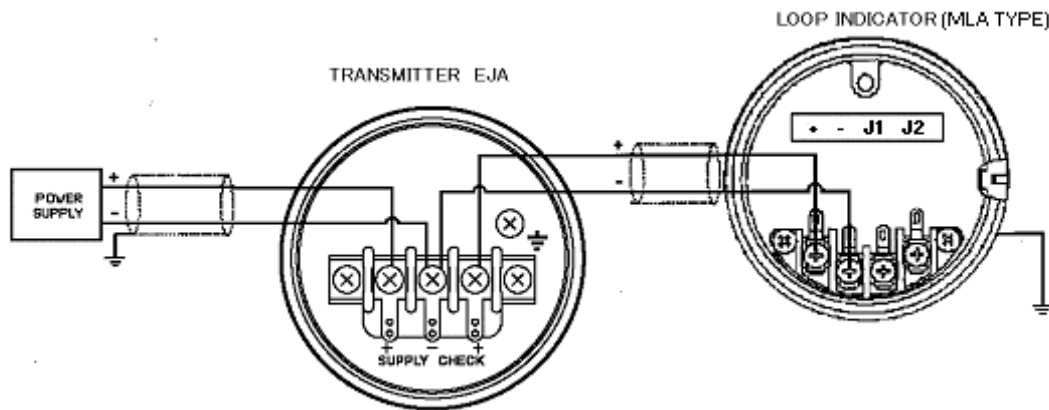

The following is another wiring example of the MLA (Analog type) or MLD (Digital type) Loop Indicator connected to an EJA Pressure Transmitter (Note: The EJA Transmitter below can be replaced with any 4-20mA 2 wire device).

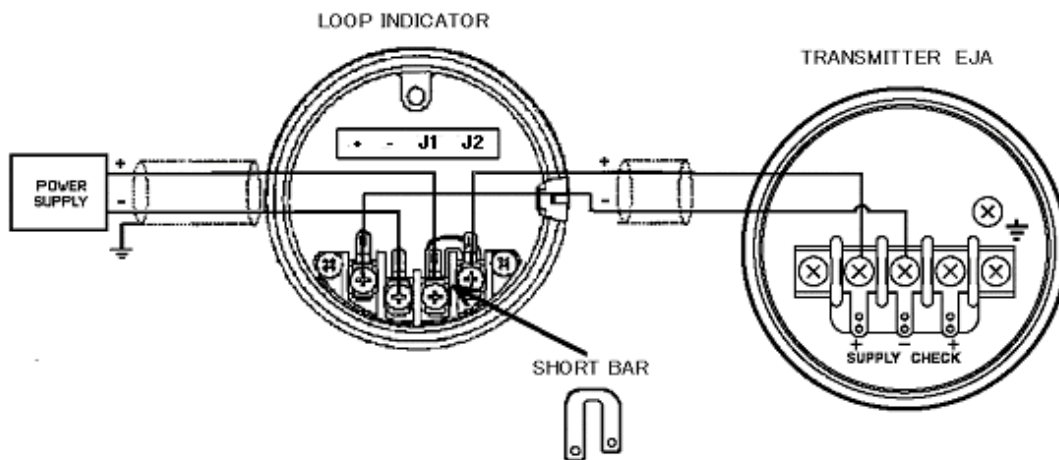

The Loop Indicator is available in FM Explosion Proof and CSA Explosion Proof types for hazardous locations. Wire sealing is required for these approvals. The following diagrams show some wire sealing examples.

GENERAL PURPOSE TYPE USING WIRING CONDUIT

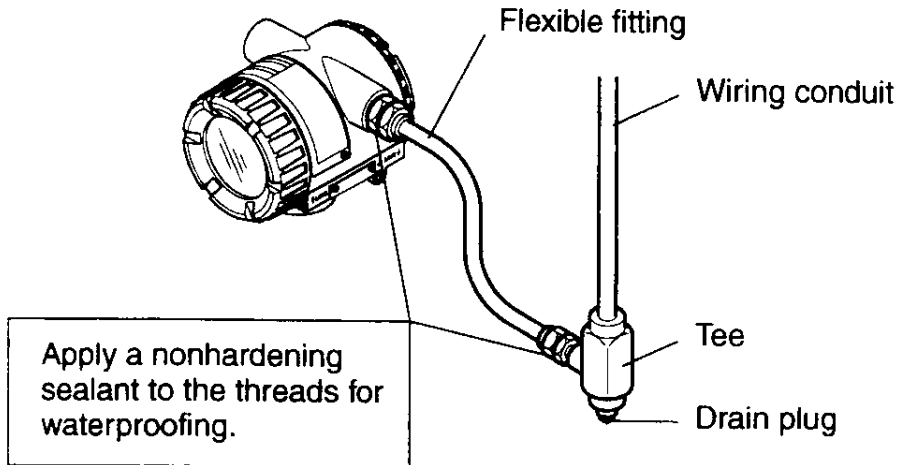

For Flameproof type use Flameproof Packing Adapter or Flameproof Conduit in connection above.

FLAMEPROOF TYPE USING FLAMEPROOF METAL CONDUIT

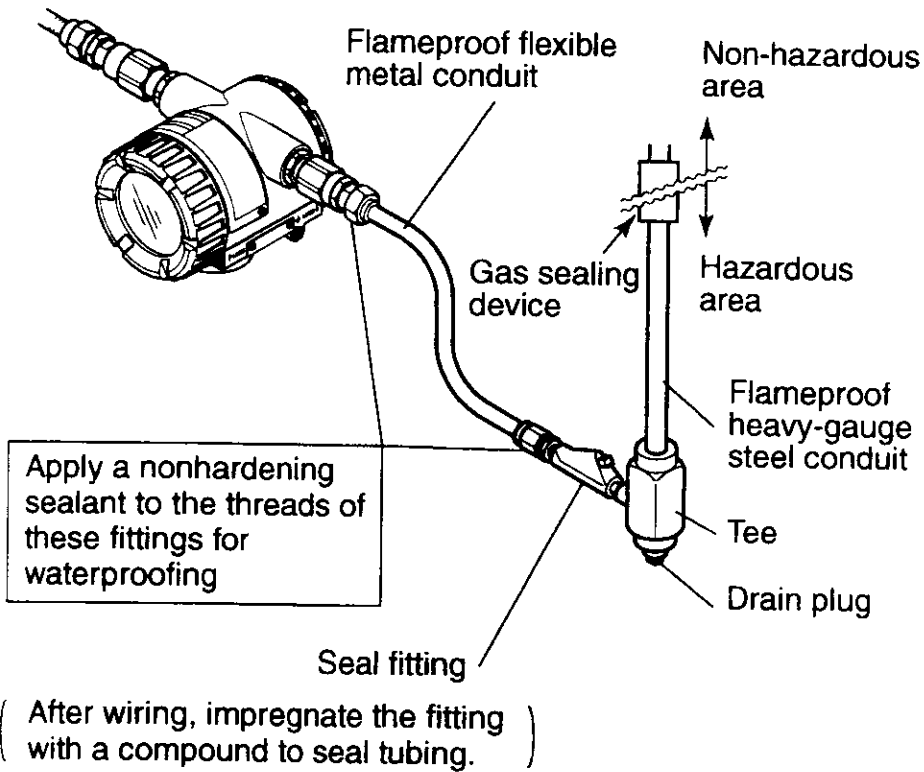

MOUNTING IN HAZARDOUS LOCATIONS

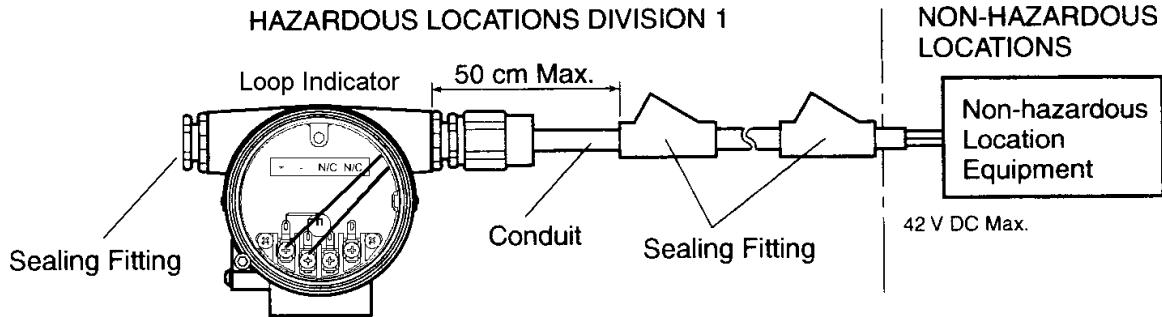

Explosionproof Class I, Groups C and D
 Dustignitionproof Class II, Groups E, F and G, Class III

Wiring method shall be suitable for the specified hazardous locations.

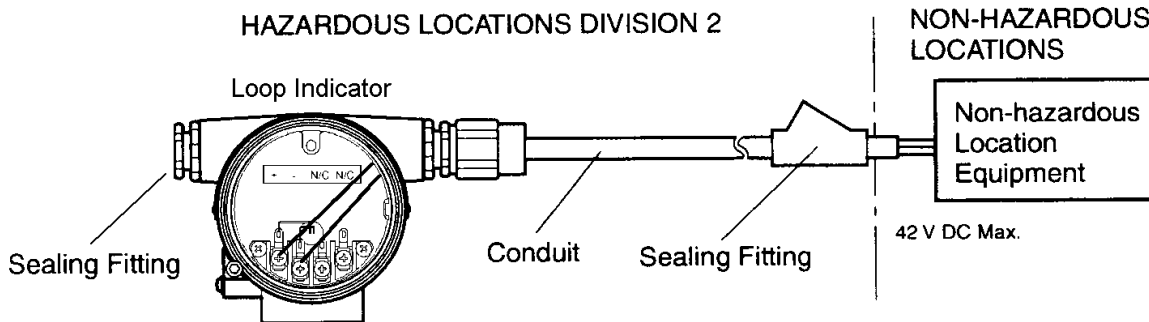

Explosionproof Class I, Groups C and D
 Dustignitionproof Class II, Groups E, F and G, Class III

Wiring method shall be suitable for the specified hazardous locations.

5. CALIBRATION

The Loop Indicators are factory calibrated to 0-100% unless the /SC (for MLA) or /ENG (for MLD) options are specified.

Calibration check for MLA Analog Type Units

- (1) The MLA model ships with a 0-100% scale unless ordered with the /SC Special Scale option.
- (2) Connect unit to Voltage/Current Standard (red to +, black to -). Voltage/Current Standards can be purchased through Yokogawa Corporation of America. Recommended models are CA11 (Voltage/Current Calibrator) or CA71 (Multifunction Calibrator).
- (3) The values to check are shown in the table below. Apply the minimum value and adjust the zero manually first. The zero adjustment can be performed by using a special tool or small needle nose pliers and twisting the white Teflon piece in the center of the meter element. Be careful not to damage the meter movement.

| | Suffix –A 4-20mA | Suffix –B 10-50mA | Suffix –C 1-5V |
|-------------|-----------------------------|------------------------------|---------------------------|
| 0% | 4.0mA | 10mA | 1.0VDC |
| 20% | 7.2mA | 18mA | 1.8VDC |
| 40% | 10.4mA | 26mA | 2.6VDC |
| 60% | 13.6mA | 34mA | 3.4VDC |
| 80% | 16.8mA | 42mA | 4.2VDC |
| 100% | 20.0mA | 50mA | 5.0VDC |

- (4) Verify the meter readings are within specification.

Calibration of MLD Digital Type Units

- (1) The MLD model ships with a calibration range of 0-100% unless ordered with the /ENG Engineering Units option.
- (2) If adjustments are needed the 2 screws holding the plate will need to be removed
- (3) Connect unit to Voltage/Current Standard (red to +, black to -). Voltage/Current Standards can be purchased through Yokogawa Corporation of America. Recommended models are CA11 (Voltage/Current Calibrator) or CA71 (Multifunction Calibrator).

- (4) Set range switches based on the following table (for standard 0-100% unit set SW1 and SW8 to ON):

| Desired Display Reading | | | SW1 | SW2 | SW3 | SW4 | SW5 |
|-------------------------|-------------------------|-------------------------|-----|-----|-----|-----|-----|
| 4mA Adjustment | 20mA Adjustment Minimum | 20mA Adjustment Maximum | | | | | |
| 000 | 1200 | 1999 | OFF | OFF | OFF | OFF | OFF |
| 000 | 600 | 1200 | ON | OFF | OFF | OFF | OFF |
| 000 | 400 | 600 | OFF | OFF | ON | OFF | OFF |
| 000 | 200 | 400 | ON | ON | ON | OFF | OFF |
| 000 | 100 | 200 | ON | ON | ON | ON | OFF |

- (5) Set the Decimal value as follows:
- If tenths (ex. XXX.X) set SW8 on.
 - If hundredths (ex. XX.XX) set SW7 on.
 - If thousandths (ex. X.XXX) set SW6 on.
- (6) The values to check are shown in the table below.

| | Suffix –A 4-20mA | Suffix –B 10-50mA | Suffix –C 1-5V |
|-------------|---------------------|----------------------|-------------------|
| 0% | 4.0mA | 10mA | 1.0VDC |
| 25% | 8.0mA | 20mA | 2.0VDC |
| 50% | 12mA | 30mA | 3.0VDC |
| 75% | 16mA | 40mA | 4.0VDC |
| 100% | 20mA | 50mA | 5.0VDC |

- (7) Set the voltage standard to the 0% value. Adjust the Zero Pot (top one) to read the minimum value needed.
- (8) Set the Voltage Standard to the 100% value. Adjust the Span Pot (bottom one) to read the maximum value needed.
- (9) Check all points in the table above and verify unit is within specification.

6. ROTATING DISPLAY DIRECTION

The loop indicator display is designed so that it can be rotated in 90 degree increments. This is accomplished by ordering the unit as a horizontal pipe mount or a vertical pipe mount. However there may be the need for the customer to change the angle of the display. The following are procedures for the display rotation:

Display rotation of MLA Analog type

WARNING: The MLA loop indicator contains a very delicate meter movement which can easily be damaged if care is not taken. When performing the following modification avoid contact with the pointer and any of the internal meter movement to avoid damage.

- (1) Remove power from the unit.
- (2) Remove the glass cover from the display side.
- (3) Remove the 2 small screws holding the scale plate onto the meter.
- (4) Carefully remove the scale from the unit (avoid touching the pointer).
- (5) You will notice 2 screws at the 9 and 3 o'clock positions in the bottom of the housing. Remove these screws.
- (6) Rotate the meter to the position desired.
- (7) Replace screws in the 9 and 3 o'clock positions and tighten firmly.
- (8) Carefully put the scale back on the unit (avoid touching the pointer).
- (9) Replace the 2 scale mounting screws.
- (10) Replace the glass cover.

Display rotation of MLD Digital type

- (1) Remove power from the unit.
- (2) Remove the glass cover from the display side.
- (3) Remove the 2 screws holding the mounting plate to the standoffs.
- (4) Rotate the display to the desired position (can be rotated in 90 degree increments).
- (5) Replace and tighten firmly the 2 screws into the standoffs.
- (6) Replace the glass cover.