

---

**User's  
Manual**

**EJX Series  
BRAIN Communication Type**

*DPharp* **EJX**<sup>™</sup>

IM 01C25T03-01E

---

**vigilantplant.**<sup>™</sup>

# CONTENTS

---

|  |            |
|--|------------|
| <b>1. INTRODUCTION .....</b>                                       | <b>1-1</b> |
| Regarding This Manual .....  | 1-1        |
| 1.1 Safe Use of This Product .....                                 | 1-2        |
| 1.2 Warranty .....   | 1-2        |
| 1.3 ATEX Documentation .....                                       | 1-3        |
| <b>2. CONDITIONS OF COMMUNICATION LINE .....</b>                   | <b>2-1</b> |
| 2.1 Connecting the BT200 .....                                     | 2-1        |
| 2.2 Communication Line Requirements .....                          | 2-1        |
| 2.3 Power Supply Voltage and Load Resistance .....                 | 2-1        |
| <b>3. OPERATION .....</b>  | <b>3-1</b> |
| 3.1 BT200 Operating Procedures .....                               | 3-1        |
| 3.1.1 Key Layout and Screen Display .....                          | 3-1        |
| 3.1.2 Operating Key Functions .....                                | 3-2        |
| (1) Alphanumeric Keys and Shift Keys .....                         | 3-2        |
| (2) Function Keys .....  | 3-2        |
| 3.1.3 Calling Up Menu Addresses Using the Operating Keys .....     | 3-3        |
| 3.1.4 Printout (for BT200 printer option) .....                    | 3-3        |
| 3.2 Setting Parameters Using the BT200 .....                       | 3-4        |
| 3.2.1 Parameter Usage and Selection .....                          | 3-4        |
| 3.2.2 Menu Tree .....  | 3-5        |
| 3.2.3 Setting Parameters .....                                     | 3-6        |
| (1) Tag No. Setup .....  | 3-6        |
| (2) Calibration Range Setup .....                                  | 3-6        |
| (3) Damping Time Constant Setup .....                              | 3-7        |
| (4) Output Mode and Integral Indicator Display Mode Setup .....    | 3-8        |
| (5) Output Signal Low Cut Mode Setup .....                         | 3-8        |
| (6) Integral Indicator Scale Setup .....                           | 3-9        |
| (7) Unit Setup for Displayed Temperature .....                     | 3-11       |
| (8) Operation Mode Setup .....                                     | 3-11       |
| (9) Impulse Line Connection Orientation Setup .....                | 3-11       |
| (10) CPU Failure Burnout Direction and Hardware Write Protect .... | 3-11       |
| (11) Software Write Protect .....                                  | 3-12       |
| (12) Output Status Setup when a Hardware Error Occurs .....        | 3-13       |
| (13) Bi-directional Flow Measurement Setup .....                   | 3-13       |
| (14) Range Change while Applying Actual Inputs .....               | 3-13       |
| (15) Sensor Trim .....   | 3-14       |
| (16) Test Output Setup .....                                       | 3-17       |
| (17) Signal Characterizer .....                                    | 3-17       |
| (18) Process Alarm .....   | 3-18       |
| (19) Status Output (option code AL) .....                          | 3-18       |
| (20) Capillary Fill Fluid Density Compensation .....               | 3-20       |
| (21) Adjustment Information and User Memo Fields .....             | 3-21       |
| 3.3 Displaying Data Using the BT200 .....                          | 3-21       |
| 3.3.1 Displaying Measured Data .....                               | 3-21       |
| 3.3.2 Display Transmitter Model and Specifications .....           | 3-21       |

**4. SELF-DIAGNOSTICS ..... 4-1**

    4.1 Checking for Problems ..... 4-1

        4.1.1 Identifying Problems with BT200 ..... 4-1

        4.1.2 Checking with Integral Indicator ..... 4-2

    4.2 Alarms and Countermeasures ..... 4-3

**5. PARAMETER SUMMARY ..... 5-1**

**APPENDIX 1. SAFETY INSTRUMENTED SYSTEMS INSTALLATION ..... A-1**

**REVISION RECORD**

# 1. INTRODUCTION

---

Thank you for purchasing the DPharp EJX electronic pressure transmitter.

EJX pressure transmitters are precisely calibrated at the factory before shipment. To ensure both safety and efficiency, please read this manual carefully before operating the instrument.

This manual describes the BRAIN protocol communication functions of the EJX series and explains how to set the parameters for EJX series pressure transmitters using the BT200 handheld terminal. For information on the installation, wiring, and maintenance of EJX series pressure transmitters, please refer to the user's manual of each model.



## WARNING

---

When using the EJX in a Safety Instrumented Systems (SIS) application, refer to Appendix 1 in this manual. The instructions and procedures in the appendix must be strictly followed in order to maintain the designed safety integrity of the transmitter.

---

### ■ Regarding This Manual

- This manual should be provided on to the end user.
- The contents of this manual are subject to change without prior notice.
- All rights reserved. No part of this manual may be reproduced in any form without Yokogawa's written permission.
- Yokogawa makes no warranty of any kind with regard to this manual, including, but not limited to, implied warranty of merchantability and fitness for a particular purpose.
- If any question arises or errors are found, or if any information is missing from this manual, please inform the nearest Yokogawa sales office.
- The specifications covered by this manual are limited to those for the standard type under the specified model number break-down and do not cover custom-made instruments.

- Please note that changes in the specifications, construction, or component parts of the instrument may not immediately be reflected in this manual at the time of change, provided that postponement of revisions will not cause difficulty to the user from a functional or performance standpoint.
- The following safety symbols are used in this manual:



## WARNING

---

Indicates a potentially hazardous situation which, if not avoided, could result in death or serious injury.

---



## CAUTION

---

Indicates a potentially hazardous situation which, if not avoided, may result in minor or moderate injury. It may also be used to alert against unsafe practices.

---



## IMPORTANT

---

Indicates that operating the hardware or software in this manner may damage it or lead to system failure.

---



## NOTE

---

Draws attention to information essential for understanding the operation and features.

---

## 1.1 Safe Use of This Product

For the safety of the operator and to protect the instrument and the system, please be sure to follow this manual's safety instructions when handling this instrument. If these instructions are not heeded, the protection provided by this instrument may be impaired. In this case, Yokogawa cannot guarantee that the instrument can be safely operated. Please pay special attention to the following points:

### (a) Installation

- This instrument may only be installed by an engineer or technician who has an expert knowledge of this device. Operators are not allowed to carry out installation unless they meet this condition.
- With high process temperatures, care must be taken not to burn yourself by touching the instrument or its casing.
- Never loosen the process connector nuts when the instrument is installed in a process. This can lead to a sudden, explosive release of process fluids.
- When draining condensate from the pressure detector section, take appropriate precautions to prevent the inhalation of harmful vapors and the contact of toxic process fluids with the skin or eyes.
- When removing the instrument from a hazardous process, avoid contact with the process fluid and the interior of the meter.
- All installation shall comply with local installation requirements and the local electrical code.

### (b) Wiring

- The instrument must be installed by an engineer or technician who has an expert knowledge of this instrument. Operators are not permitted to carry out wiring unless they meet this condition.
- Before connecting the power cables, please confirm that there is no current flowing through the cables and that the power supply to the instrument is switched off.

### (c) Operation

- Wait 10 min. after the power is turned off before opening the covers.

### (d) Maintenance

- Please carry out only the maintenance procedures described in this manual. If you require further assistance, please contact the nearest Yokogawa office.
- Care should be taken to prevent the build up of dust or other materials on the display glass and the name plate. To clean these surfaces, use a soft, dry cloth.

### (e) Modification

- Yokogawa will not be liable for malfunctions or damage resulting from any modification made to this instrument by the customer.

## 1.2 Warranty

- The warranty shall cover the period noted on the quotation presented to the purchaser at the time of purchase. Problems occurring during the warranty period shall basically be repaired free of charge.
- If any problems are experienced with this instrument, the customer should contact the Yokogawa representative from which this instrument was purchased or the nearest Yokogawa office.
- If a problem arises with this instrument, please inform us of the nature of the problem and the circumstances under which it developed, including the model specification and serial number. Any diagrams, data and other information you can include in your communication will also be helpful.
- The party responsible for the cost of fixing the problem shall be determined by Yokogawa following an investigation conducted by Yokogawa.
- The Purchaser shall bear the responsibility for repair costs, even during the warranty period, if the malfunction is due to:
  - Improper and/or inadequate maintenance by the purchaser.
  - Malfunction or damage due to a failure to handle, use, or store the instrument in accordance with the design specifications.
  - Use of the product in question in a location not conforming to the standards specified by Yokogawa, or due to improper maintenance of the installation location.
  - Failure or damage due to modification or repair by any party except Yokogawa or an approved representative of Yokogawa.
  - Malfunction or damage from improper relocation of the product in question after delivery.
  - Reason of force majeure such as fires, earthquakes, storms/floods, thunder/lightening, or other natural disasters, or disturbances, riots, warfare, or radioactive contamination.

### 1.3 ATEX Documentation

This section is only applicable to the countries in the European Union.

GB

All instruction manuals for ATEX Ex related products are available in English, German and French. Should you require Ex related instructions in your local language, you are to contact your nearest Yokogawa office or representative.

DK

Alle brugervejledninger for produkter relateret til ATEX Ex er tilgængelige på engelsk, tysk og fransk. Skulle De ønske yderligere oplysninger om håndtering af Ex produkter på eget sprog, kan De rette henvendelse herom til den nærmeste Yokogawa afdeling eller forhandler.

I

Tutti i manuali operativi di prodotti ATEX contrassegnati con Ex sono disponibili in inglese, tedesco e francese. Se si desidera ricevere i manuali operativi di prodotti Ex in lingua locale, mettersi in contatto con l'ufficio Yokogawa più vicino o con un rappresentante.

E

Todos los manuales de instrucciones para los productos antiexplosivos de ATEX están disponibles en inglés, alemán y francés. Si desea solicitar las instrucciones de estos artículos antiexplosivos en su idioma local, deberá ponerse en contacto con la oficina o el representante de Yokogawa más cercano.

NL

Alle handleidingen voor producten die te maken hebben met ATEX explosiebeveiliging (Ex) zijn verkrijgbaar in het Engels, Duits en Frans. Neem, indien u aanwijzingen op het gebied van explosiebeveiliging nodig hebt in uw eigen taal, contact op met de dichtstbijzijnde vestiging van Yokogawa of met een vertegenwoordiger.

SF

Kaikkien ATEX Ex -tyyppisten tuotteiden käyttöohjeet ovat saatavilla englannin-, saksan- ja ranskankielisinä. Mikäli tarvitsette Ex -tyyppisten tuotteiden ohjeita omalla paikallisella kielellänne, ottakaa yhteyttä lähimpään Yokogawa-toimistoon tai -edustajaan.

P

Todos os manuais de instruções referentes aos produtos Ex da ATEX estão disponíveis em Inglês, Alemão e Francês. Se necessitar de instruções na sua língua relacionadas com produtos Ex, deverá entrar em contacto com a delegação mais próxima ou com um representante da Yokogawa.

F

Tous les manuels d'instruction des produits ATEX Ex sont disponibles en langue anglaise, allemande et française. Si vous nécessitez des instructions relatives aux produits Ex dans votre langue, veuillez bien contacter votre représentant Yokogawa le plus proche.

D

Alle Betriebsanleitungen für ATEX Ex bezogene Produkte stehen in den Sprachen Englisch, Deutsch und Französisch zur Verfügung. Sollten Sie die Betriebsanleitungen für Ex-Produkte in Ihrer Landessprache benötigen, setzen Sie sich bitte mit Ihrem örtlichen Yokogawa-Vertreter in Verbindung.

S

Alla instruktionsböcker för ATEX Ex (explosionssäkra) produkter är tillgängliga på engelska, tyska och franska. Om Ni behöver instruktioner för dessa explosionssäkra produkter på annat språk, skall Ni kontakta närmaste Yokogawakontor eller representant.

GR

Όλα τα εγχειρίδια λειτουργίας των προϊόντων με ATEX Ex διατίθενται στα Αγγλικά, Γερμανικά και Γαλλικά. Σε περίπτωση που χρειάζεστε οδηγίες σχετικά με Ex στην τοπική γλώσσα παρακαλούμε επικοινωνήστε με το πλησιέστερο γραφείο της Yokogawa ή αντιπρόσωπο της.

SK

Všetky návody na obsluhu pre prístroje s ATEX Ex sú k dispozícii v jazyku anglickom, nemeckom a francúzskom. V prípade potreby návodu pre Ex-prístroje vo Vašom národnom jazyku, skontaktujte prosím miestnu kanceláriu firmy Yokogawa.

CZ

Všechny uživatelské příručky pro výrobky, na něž se vztahuje nevybušné schválení ATEX Ex, jsou dostupné v angličtině, němčině a francouzštině. Požadujete-li pokyny týkající se výrobků s nevybušným schválením ve vašem lokálním jazyku, kontaktujte prosím vaši nejbližší reprezentační kancelář Yokogawa.

LT

Visos gaminiø ATEX Ex kategorijos Eksploatavimo instrukcijos teikiami anglø, vokieèiø ir prancûzø kalbomis. Norëdami gauti prietaisø Ex dokumentacijà kitomis kalbomis susisiekite su artimiausiu bendrovës “Yokogawa” biuru arba atstovu.

LV

Visas ATEX Ex kategorijas izstrādājumu Lietošanas instrukcijas tiek piegādātas angļu, vācu un franču valodās. Ja vēlaties saņemt Ex ierīšu dokumentāciju citā valodā, Jums ir jāsazinās ar firmas Jokogava (Yokogawa) tuvāko ofisu vai pārstāvi.

EST

Kõik ATEX Ex toodete kasutamishendid on esitatud inglise, saksa ja prantsuse keeles. Ex seadmete muukeelse dokumentatsiooni saamiseks pöörduge lähima Iokagava (Yokogawa) kontori või esindaja poole.

PL

Wszystkie instrukcje obsługi dla urządzeń w wykonaniu przeciwwybuchowym Ex, zgodnych z wymaganiami ATEX, dostępne są w języku angielskim, niemieckim i francuskim. Jeżeli wymagana jest instrukcja obsługi w Państwa lokalnym języku, prosimy o kontakt z najbliższym biurem Yokogawy.

SLO

Vsi predpisi in navodila za ATEX Ex sorodni pridelki so pri roki v angleščini, nemščini ter francoščini. Če so Ex sorodna navodila potrebna v vašem tukejnem jeziku, kontaktirajte vaš najbliži Yokogawa office ili predstavnika.

H

Az ATEX Ex műszerek gépkönyveit angol, német és francia nyelven adjuk ki. Amennyiben helyi nyelven kérik az Ex eszközök leírásait, kérjük keressék fel a legközelebbi Yokogawa irodát, vagy képviselőtet.

BG

Всички упътвания за продукти от серията ATEX Ex се предлагат на английски, немски и френски език. Ако се нуждаете от упътвания за продукти от серията Ex на родния ви език, се свържете с най-близкия офис или представителство на фирма Yokogawa.

RO

Toate manualele de instructiuni pentru produsele ATEX Ex sunt in limba engleza, germana si franceza. In cazul in care doriti instructiunile in limba locala, trebuie sa contactati cel mai apropiat birou sau reprezentant Yokogawa.

M

Il-manwali kollha ta' l-istruzzjonijiet għal prodotti marbuta ma' ATEX Ex huma disponibbli bl-Ingliż, bil-Ġermaniż u bil-Franċiż. Jekk tkun teħtieġ struzzjonijiet marbuta ma' Ex fil-lingwa lokali tiegħek, għandek tikkuntattja lill-eqreb rappreżentant jew ufficċju ta' Yokogawa.

# 2. CONDITIONS OF COMMUNICATION LINE

The BRAIN communication signal is superimposed onto the 4 to 20 mA DC analog signal. Since the modulated wave is a communication signal, superimposing it on the normal signal will, from basic principles, cause no error in the DC component of the analog signal. Thus, monitoring can be performed via the BT200 while the transmitter is on-line.

## 2.1 Connecting the BT200

Connection to the transmitter with the BT200 can be made by either connecting to the BT200 connection hooks in the transmitter terminal box or by connecting to a relaying terminal or a terminal board.

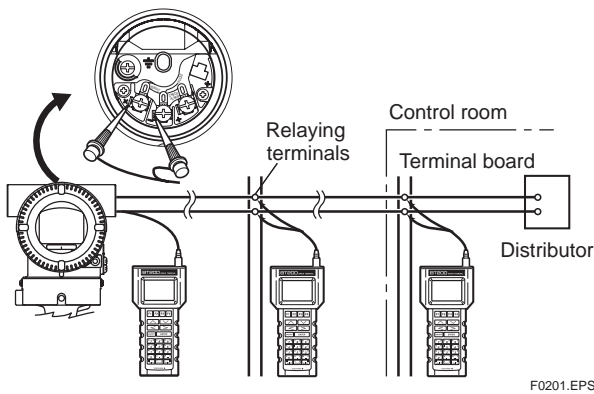

Figure 2.1 Connecting the BT200

## 2.2 Communication Line Requirements

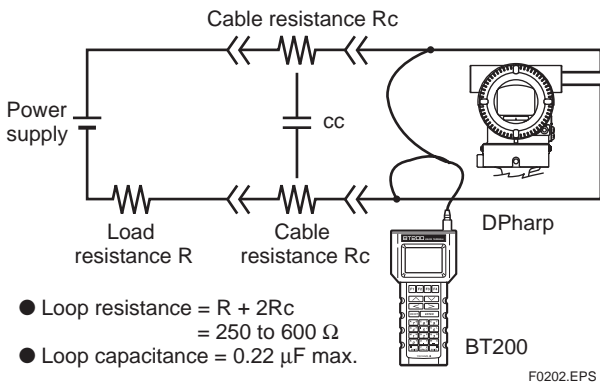

Figure 2.2 Communication Line Requirements

## 2.3 Power Supply Voltage and Load Resistance

When configuring the loop, make sure that the external load resistance is within the range in the figure below.

(Note) With an intrinsically safe transmitter, external load resistance includes safety barrier resistance.

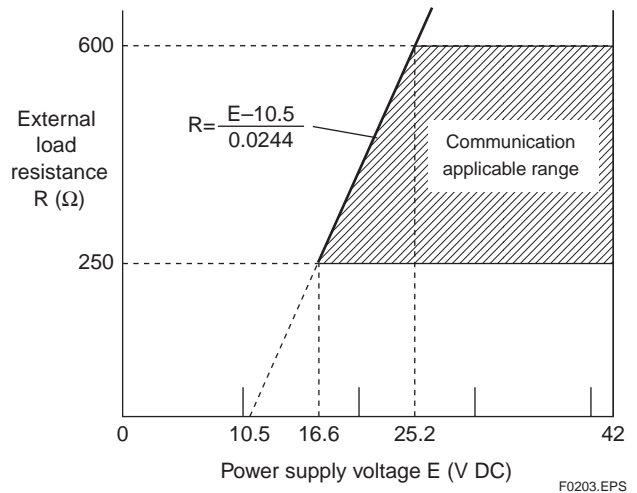

Figure 2.3 Relationship between Power Supply Voltage and External Load Resistance

# 3. OPERATION

The DPharp is equipped with BRAIN communications capabilities, so that range changes, Tag No. setup, monitoring of self-diagnostic results, and zero point adjustment can be handled remotely via the BT200 BRAIN TERMINAL or the CENTUM CS console. This section describes procedures for setting parameters using the BT200. For further information on the BT200, see the BT200 User's Manual (IM 01C00A11-01E).

## 3.1 BT200 Operating Procedures

### 3.1.1 Key Layout and Screen Display

Figure 3.1.1a shows the arrangement of the operating keys on the BT200 keypad, and figure 3.1.1b shows the BT200 screen.

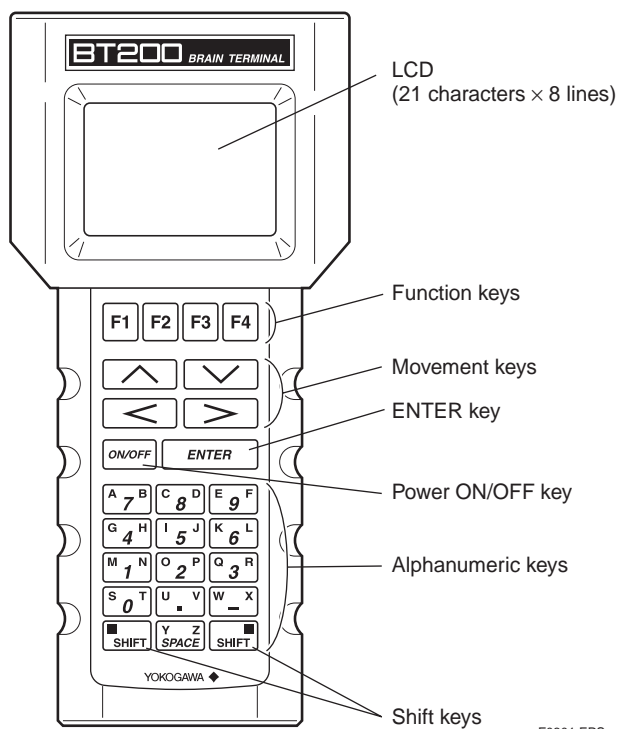
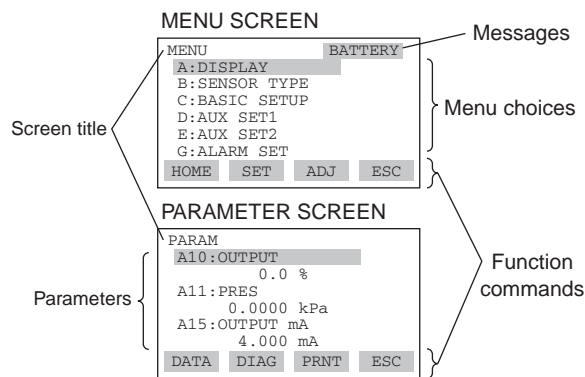

Figure 3.1.1a BT200 Key Layout



F0302.EPS

Figure 3.1.1b BT200 Screen

### 3.1.2 Operating Key Functions

#### (1) Alphanumeric Keys and Shift Keys

Use the alphanumeric keys in conjunction with the shift keys to enter numbers, symbols, and alphabetic characters.

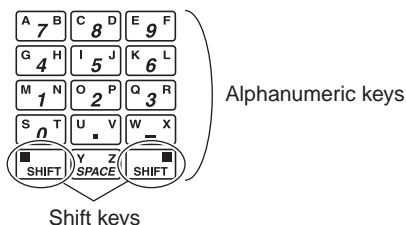

F0303.EPS

#### a. Entering Numbers, Symbols, and Spaces

Simply press the alphanumeric keys.

| Entry | Key-in sequence |
|-------|-----------------|
| -4    |                 |
| 0.3   |                 |
| 1 -9  |                 |

T0301.EPS

#### b. Entering Alphabetic Characters

Press either the left or right shift key and then an alphanumeric key to enter the desired alphabetic character. The shift key must be pressed each time an alphabetic character is entered.

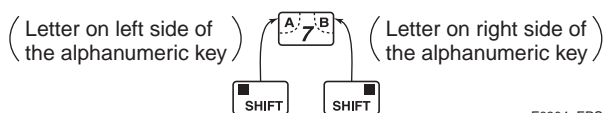

F0304 .EPS

| Entry | Key-in sequence |
|-------|-----------------|
| W     |                 |
| IC    |                 |
| J. B  |                 |

T0302.EPS

Use the function key [F2] CAPS to select uppercase and lowercase (for alphabetic characters only). The case toggles between uppercase and lowercase each time [F2] CAPS is pressed.

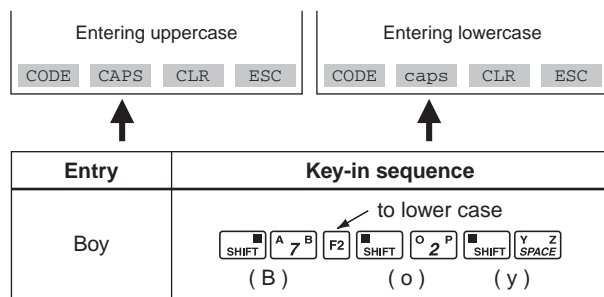

F0305.EPS

Use the function key [F1] CODE to enter symbols. The following symbols will appear in sequence, one at a time, at the cursor each time [F1] CODE is pressed:

/ . - , + \* ) ( ' & % \$ # " !

To enter characters next to these symbols, press [ > ] to move the cursor.

| Entry | Key-in Sequence                         |
|-------|---|
| l/m   | symbol command<br><br>( l ) ( / ) ( m ) |

T0303.EPS

#### (2) Function Keys

The function command carried out by each function key is displayed directly above the key.

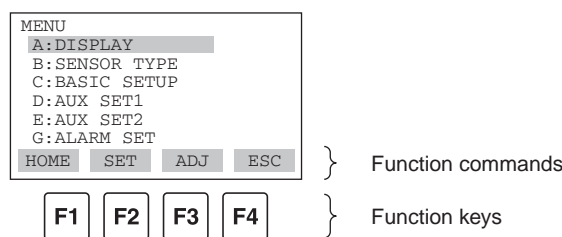

F0306.EPS

#### Function Command List

| Command   | Function  |
|-----------|---|
| ADJ       | Displays the ADJ menu                           |
| CAPS/caps | Selects uppercase or lowercase                  |
| CODE      | Selects symbols                                 |
| CLR       | Erases input data or deletes all data           |
| DATA      | Updates parameter data                          |
| DEL       | Deletes one character                           |
| DIAG      | Calls the self-check panel                      |
| ESC       | Returns to the most recent display              |
| HOME      | Displays the menu panel                         |
| NO        | Quits setup and returns to the previous display |
| OK        | Proceeds to the next panel                      |
| PARM      | Enters the parameter number setup mode          |
| SET       | Displays the SET menu                           |
| SLOT      | Returns to the slot selection panel             |
| UTIL      | Calls the utility panel                         |
| *COPY     | Prints out parameters on display                |
| *FEED     | Paper feed                                      |
| *LIST     | Lists all parameters in the menu                |
| *PON/POFF | Automatic printout mode on or off               |
| *PRNT     | Changes to the print mode                       |
| *GO       | Starts printing                                 |
| *STOP     | Cancels printing                                |

\* Available on BT200-P00 (with printer).

T0304.EPS

### 3.1.3 Calling Up Menu Addresses Using the Operating Keys

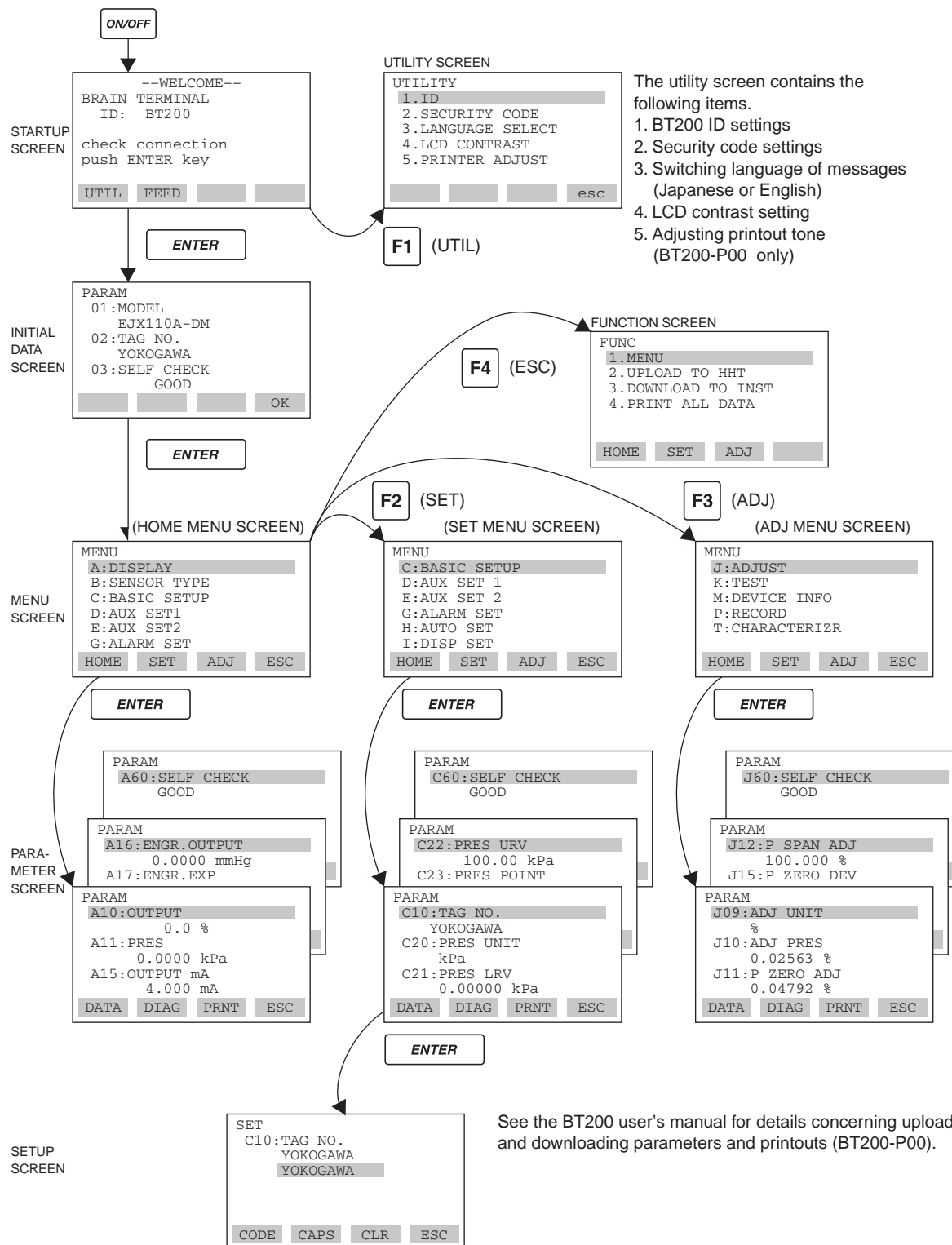

F0307.EPS

### 3.1.4 Printout (for BT200 printer option)

#### (1) Printout of All Parameters

Select 4. *PRINT ALL DATA* from the function screen to output a list of all parameters. It takes about 10 minutes to complete the printout.

#### (2) Printout by Menu Item

To printout the parameters for a specific screen, push the function key corresponding to screen's PRINT.

## 3.2 Setting Parameters Using the BT200



After setting and sending data with the BT200, wait 30 seconds before turning off the transmitter. If it is turned off too soon, the settings will not be stored in the transmitter.

### 3.2.1 Parameter Usage and Selection

Before setting a parameter, please see the following table for a summary of how and when each parameter is used.

Table 3.2.1 Parameter Usage and Selection

| Setup item   | Description  |
|--|--|
| <b>Tag No. setup ▶ P.3-6</b>   | Sets the Tag No. (using 16 alphanumeric characters).   |
| <b>Calibration range setup ▶ P.3-6</b>   | Sets the calibration range for 4 to 20 mA DC. Sets the following items: range unit, input value at 4 mA DC (LRV), input value at 20 mA DC (URV), and decimal point position.<br>Note: LRV and URV can be specified with range value specifications up to 5 digits (excluding any decimal point) within the range of -32000 to 32000.   |
| <b>Damping time constant setup ▶ P.3-7</b>   | Adjusts the output response speed for 4 to 20 mA DC at amplifier.<br>Can be set from 0.50 to 100.00 s. (from 0.00 to 100.00 s with quick response mode on)   |
| <b>Output and integral indicator display mode setup ▶ P.3-8</b>                                | Sets modes for output signal and integral indicator to Linear mode (proportional to input differential pressure) or to Square root mode (proportional to flow).  |
| <b>Output signal low cut mode setup ▶ P.3-8</b>  | Used mainly to stabilize output near 0% if the output signal is square root mode.<br>Two modes are available: forcing output to 0% for input below a specific value, or changing to proportional output for input below a specific value.  |
| <b>Integral indicator display function ▶ P.3-9</b>   | Available from the following 5 types of integral indicator scale ranges and units:<br>input pressure, % of range, user set scale, input static pressure, % of static pressure range, and alternating among any four of the above.<br>Configure the following when using the user set scale;<br>user set scale setting, unit (BT200 only), display value at 4 mA DC (LRV), and display value at 20 mA DC (URV).<br>Note: LRV and URV can be specified with range value specifications up to 5 digits (excluding any decimal point) within the range of -32000 to 32000. |
| <b>Unit setup for displayed temperature ▶ P.3-11</b>   | Sets the unit for temperatures displayed on the BT200.   |
| <b>Static pressure setup ▶ P.3-11</b>  | Sets the parameters concerned with static pressure such as unit, calibration range, upper and lower range values, decimal point position, damping time constant.   |
| <b>Operation mode (normal/reverse signal) setup ▶ P.3-11</b>                                   | Reverses the direction for 4 to 20 mA DC output relative to input.<br>Reverse mode is used for applications in which safety requires that output be driven toward 20 mA if input is lost.  |
| <b>Impulse line connection orientation (higher pressure on right/left side) setup ▶ P.3-11</b> | Used where installation conditions make it imperative to connect high pressure side impulse line to low pressure side of transmitter. Reversal of orientation should be dealt with by reversing impulse line wherever possible. Use this function only where there is no alternative.  |
| <b>CPU Failure burnout direction and hardware write protect ▶ P.3-11</b>                       | Displays the status of 4 to 20 mA DC output when a CPU fails. The direction is selectable by the hardware switch on the amplifier. It also physically prevents parameter access.   |
| <b>Software write protect ▶ P.3-12</b>   | Configured data can be protected by setting a password.  |
| <b>Output status setup when a hardware error occurs ▶ P.3-13</b>                               | Sets the status of the 4 to 20 mA DC output when an abnormal status is detected with the capsule or the amplifier as the result of self-diagnosis. Either the last held, high limit, or low limit values status, can be selected.  |
| <b>Bi-directional flow measurement ▶ P.3-13</b>  | Used to measure bi-directional flows. Output at zero flow is 12 mA DC, with output range equally divided between forward and reverse flow. Can be used with square root mode.  |
| <b>Range change (while applying actual inputs) ▶ P.3-13</b>                                    | Range for 4 to 20 mA DC signal is set with actual input applied. Sets 20 mA DC output precisely with respect to user's reference instrument output. Note that DPharp is calibrated with high accuracy before shipment, so span should be set using the normal range setup.   |
| <b>Sensor trim ▶ P.3-14</b>  | Adjusts zero point and span of the sensor.   |
| <b>Test output (fixed current output) setup ▶ P.3-17</b>                                       | Used for loop checks.<br>Output can be set freely from -2.50% to 110.00% in 0.01% steps.   |
| <b>Signal characterizer ▶ P.3-17</b>   | Used to compensate the output for the non-linear application.  |
| <b>Process alarm ▶ P.3-18</b>  | Used for alarm generation on the integral indicator.   |
| <b>Status output ▶ P.3-18</b>  | Outputs an on/off digital signal based on the settings of process alarm.   |
| <b>Capillary fill fluid density compensation ▶ P.3-20</b>                                      | Compensates the zero shift by the ambient temperature effect on the capillary tubes.   |
| <b>User memo fields ▶ P.3-21</b>   | Allows user to enter up to 3 items, each containing any combination of up to 16 alphanumeric characters.   |

### 3.2.2 Menu Tree

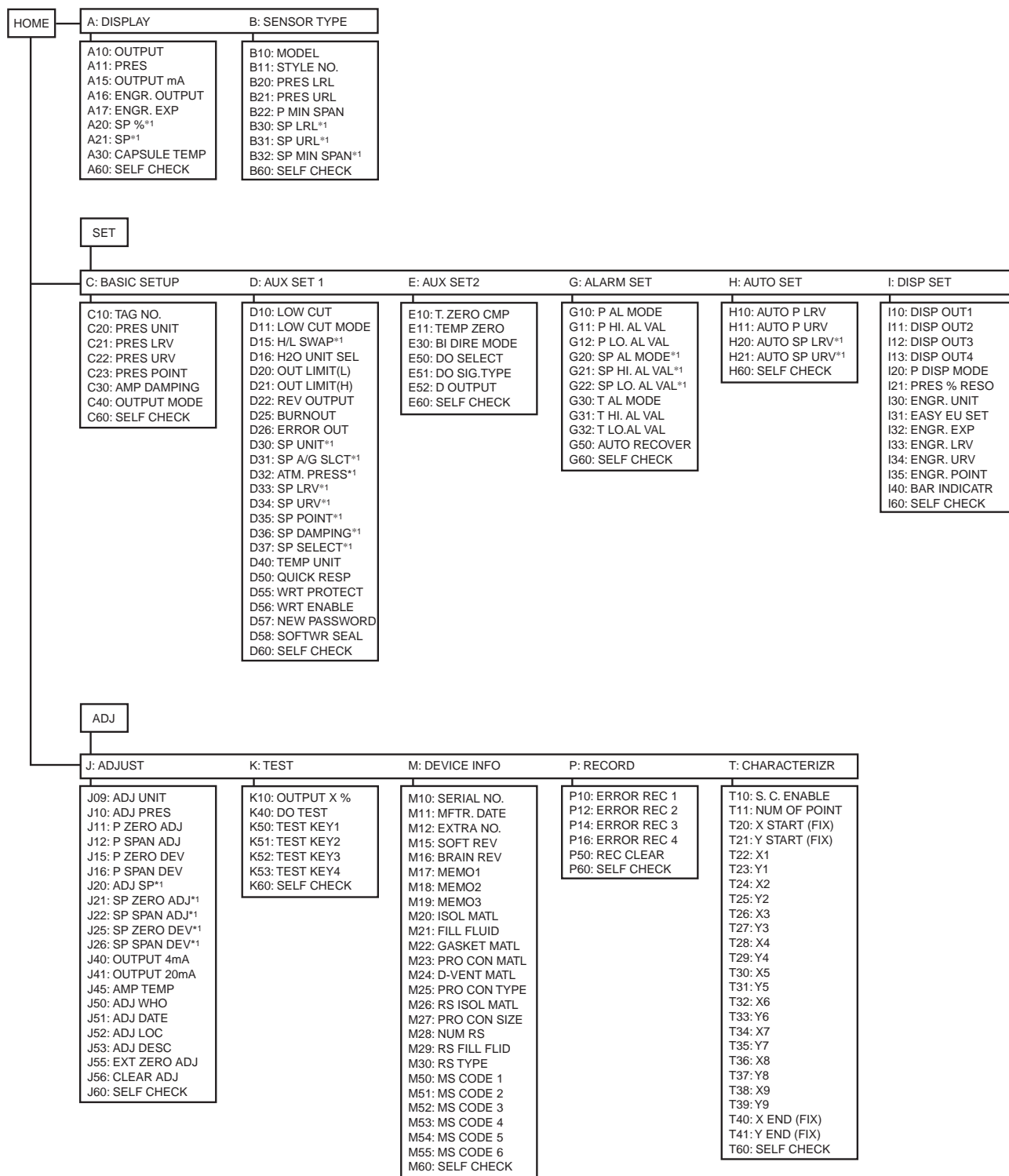

\*1: Available for differential pressure transmitter.

### 3.2.3 Setting Parameters

Set or change the parameters as necessary. After completing these, do not fail to use the “DIAG” key to confirm that “GOOD” is displayed for the self-diagnostic result at **\_60: SELF CHECK**.

#### (1) Tag No. Setup (C10: TAG NO)

Use the procedure below to change the Tag No. Up to 16 alphanumeric characters can be entered.

**• Example: Set a Tag No. to F11-1a**

Press the **ON/OFF** key to turn on the BT200.

Connect DPharp and BT200 using a communication cable and press the **ENTER** key.

Displays the name of connected DPharp model, TAG NO. and diagnostics information. Press the **F4** (OK) key after confirmation.

Press the **F2** (SET) key to display the SET menu panel.

Select C: BASIC SETUP and press the **ENTER** key.

Select C10: TAG NO. and press the **ENTER** key.

Set the new TAG NO. (F11-1a).

Set TAG NO. and press the **ENTER** key.

(When you have made an entry mistake, return the cursor **<** using the key, then reenter.)

F0308.EPS

This is the panel for confirming set data. The set data items flash. When all items have been confirmed, press the **ENTER** again. (To go back to the setting panel, press the **F3** (NO) key.

The DPharp TAG NO. was overwritten. Press the **F4** (OK) key to return to the parameter panel. Press the **F3** (NO) key to return to the setting panel.

F0309.EPS

#### (2) Calibration Range Setup

##### a. Setting Calibration Range Unit (C20: PRES UNIT)

The unit parameter is set at the factory before shipment if specified at the time of order. Follow the procedure below to change the unit parameter.

**• Example: Change the unit from mmH2O to kPa.**

Use the **↑** or **↓** key to select **kPa**. Press the **ENTER** key twice to enter the setting.

Press the **F4** (OK) key.

F0310.EPS

Note that the Yokogawa default setting for the standard temperature is 4°C (39.2°F). For the units of mmH<sub>2</sub>O, mmAq, mmWG, inH<sub>2</sub>O, and ftH<sub>2</sub>O, the pressure varies according to the standard temperature definition. When a standard temperature of 20°C (68°F) is required, select @20degC (68.0F) at the parameter of D16:H2O UNIT SEL.

Available pressure units are shown below.

|       |                     |       |
|-------|---------------------|-------|
| mmH2O | MPa                 | inHg  |
| mmAq  | mbar                | ftH2O |
| mmWG  | bar                 | psi   |
| mmHg  | gf/cm <sup>2</sup>  | atm   |
| Torr  | kgf/cm <sup>2</sup> | Pa    |
| kPa   | inH2O               | hPa   |

FX0301.EPS

**b. Setting Calibration Range Lower Range Value and Upper Range Value (C21: PRES LRV, C22: PRES URV)**

These range values are set as specified in the order before the instrument is shipped. Follow the procedure below to change the range.

- The measurement span is determined by the upper and lower range limit values. In this instrument, changing the lower range value also automatically changes the upper range value, keeping the span constant.

• Example 1: With present settings of 0 to 30 kPa, set the lower range value to 0.5 kPa.

```
SET
C21: PRES LRV
      0 kPa
+ 0.5
```

DEL CLR ESC

**Set 0.5.**  
Press the **ENTER** key twice to enter the setting.

```
SET
C21: PRES LRV
      0.5 kPa
```

FEED NO OK

Press the **F4** (OK) key.

```
PARAM
C20: PRES UNIT
      kPa
C21: PRES LRV
      0.5 kPa
C22: PRES URV
      30.5 kPa
```

DATA DIAG PRNT ESC

The upper range value is changed while the span remains constant.

$$\left( \text{Span} = \text{Upper range value} - \text{Lower range value} \right)$$

F0311.EPS

- Entering the range values as LRV>URV reverses the direction of the output signal of 4-20 mA to 20-4 mA corresponding to the calibration range of 0 to 100%.
- Calibration range can be specified with range value specifications up to 5 digits (excluding any decimal point) for lower or upper range limits within the range of -32000 to 32000.
- Note, however, that changing the upper range value does not cause the lower range value to change. Thus, changing the upper range value also changes the span.

• Example 2: With present settings of 0 to 30 kPa, set the upper range value to 10 kPa.

```
SET
C22: PRES URV
      30 kPa
+ 10
```

DEL CLR ESC

**Set 10.**  
Press the **ENTER** key twice to enter the setting.

```
SET
C22: PRES URV
      10 kPa
```

FEED NO OK

Press the **F4** (OK) key.

```
PARAM
C20: PRES UNIT
      kPa
C21: PRES LRV
      0 kPa
C22: PRES URV
      10 kPa
```

DATA DIAG PRNT ESC

The lower range value is not changed, so the span changes.

F0312.EPS

**(3) Damping Time Constant Setup (C30: AMP DAMPING)**

When the instrument is shipped, the damping time constant is set at 2.00 seconds unless otherwise specified in the order. Follow the procedure below to change the damping time constant.

Note that setting the quick response parameter (D50: QUICK RESP) ON enables you to set the damping time constant between 0.00 to 0.49 second.

• Example: Change from 2.00 sec to 4.00 sec.

```
SET
C30: AMP DAMPING
      2.00 sec
+ 004.00
```

CLR ESC

**Enter 4.**  
Press the **ENTER** key twice to enter the setting.

```
SET
C30: AMP DAMPING
      4.00 sec
```

FEED NO OK

Press the **F4** (OK) key.

F0313.EPS

Note 1: The damping time constant set here is the time constant for the amplifier assembly. The damping time constant for the entire transmitter is the sum of the values for the amplifier assembly and for the capsule assembly.

Note 2: When the damping time constant is set to less than 0.5 second, communication may occasionally be unavailable during the operation, especially while output changes dynamically.

#### (4) Output Mode and Integral Indicator Display Mode Setup (C40: OUTPUT MODE, I20: P DISP MODE)

The mode setting for the output signal and the integral indicator can be performed independently.

This mode is set as specified in the order when the instrument is shipped. Follow the procedure below to change the mode.

If the instrument is equipped with an integral indicator and the display mode is **SQUARE ROOT**, “√” is displayed on the integral indicator.

- Output mode for 4-20 mA output

• Example: Set output mode from **Linear** to **Square root**.

```
SET
C40:OUTPUT MODE
  LINEAR
< LINEAR >
< SQUARE ROOT >
FEED CLR ESC
```

Use the or key to select **SQUARE ROOT**.

Press the key twice to enter the setting.

```
SET
C40:OUTPUT MODE
  SQUARE ROOT
FEED CLR NO OK
```

Press the (OK) key.

F0314.EPS

- Integral indicator display mode

• Example: Set display mode from **Linear** to **Square root**.

```
SET
I20:P DISP MODE
  LINEAR
< LINEAR >
< SQUARE ROOT >
FEED CLR ESC
```

Use the or key to select **SQUARE ROOT**.

Press the key twice to enter the setting.

```
SET
I20:P DISP MODE
  SQUARE ROOT
FEED CLR NO OK
```

Press the (OK) key.

F0315.EPS

#### (5) Output Signal Low Cut Mode Setup (D10: LOW CUT, D11: LOW CUT MODE)

Low cut mode can be used to stabilize the output signal near the zero point. The low cut point can be set in a range from 0 to 20%, the direct ratio corresponding to the output signal of 4 to 20 mA. (Hysteresis:  $\pm 10\%$  of the cut point)

Either **LINEAR** or **ZERO** can be selected as the low cut mode. Unless otherwise specified, the cut mode is set to **LINEAR** at the factory.

Note that when the output modes of the output signal and the integral indicator are selected as **SQUARE ROOT** and **LINEAR** accordingly, the low cut function is not available for the integral indicator display.

• Example: Change the low cut setting range from 10% to 20%, and the low cut mode from **LINEAR** to **ZERO** in the **SQUARE ROOT** output mode.

● Low cut mode "LINEAR"

● Low cut mode "ZERO"

```
SET
D10:LOW CUT
  10.00 %
+ 20.00
FEED CLR ESC
```

Set **20**.

Press the key twice to enter the setting.

```
SET
D10:LOW CUT
  20.00 %
FEED CLR NO OK
```

Press the (OK) key.

Next, the [D11: LOW CUT MODE] setting panel is displayed.

```
SET
D11:LOW CUT MODE
  LINEAR
< LINEAR >
< ZERO >
FEED CLR ESC
```

Use the or key to select **ZERO**.

Press the key twice to enter the setting.

```
SET
D11:LOW CUT MODE
  ZERO
FEED CLR NO OK
```

Press the (OK) key.

```
PARAM
D10:LOW CUT
  20.0 %
D11:LOW CUT MODE
  ZERO
D15:H/L SWAP
  NORMAL
DATA DIAG PRNT ESC
```

F0317.EPS

The low cut point has hysteresis so that the output around the point is behaved as below figure.

<Example>

Output mode: Linear

Low cut mode: Zero

Low cut: 20.00%

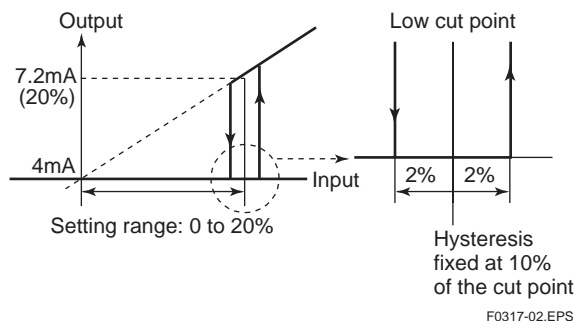

### (6) Integral Indicator Scale Setup

The following five displays are available for integral indicators: input pressure\*1, % of range, user set scale, input static pressure, and % of static pressure range\*1. A cycle of up to four displays can be shown by assigning variables to the parameters I10 to I13: DISP OUT1 to DISP OUT4.

| Available displays                      | Description and related parameters   |
|---|--|
| Input pressure (PRES)<br>               | Indicates values of input pressure with the indication limits -32000 to 32000.<br><br>A11: PRES<br>456 kPa   |
| % of range (PRES %)<br>                 | Indicates input pressure in -2.5 to 110% range depending on the measuring range (C21, C22).<br><br>A10: OUTPUT<br>45.6 %   |
| User set scale (ENGR. PRES)<br>         | Indicates values depending on the engineering range (I33, I34) with the unit (I30).<br><br>A16: ENGR. OUTPUT<br>20.5 m <sup>3</sup> /min<br>A17: ENGR. EXP<br>×100 |
| Input static pressure (SP)*1<br>        | Indicates input static pressure with the indication limits -32000 to 32000. Reference pressure is factory-set in absolute.<br><br>A21: SP<br>4.000 MPa             |
| % of static pressure range (SP %)*1<br> | Indicates input static pressure in -10 to 110% range depending on the measuring range (D33, D34).<br><br>A20: SP %<br>52.6 %                                       |

T0306.EPS

\*1: Available for differential pressure transmitter.

See (a.) through (d.) for each setting procedure.

**a. Display Selection  
(I10: DISP OUT1)**

Select the variable for the parameter I10: DISP OUT1 to display on the integral indicator.

- Example: Change the integral indicator scale from % of range to input pressure display.

Use the or key to select **PRES**.

Press the key twice to enter the setting.

Press the (OK) key.

F0318.EPS

**b. Cyclic Display  
(I11: DISP OUT2, I12: DISP OUT3, and I13: DISP OUT4)**

In addition to the display set at I10: DISP OUT1, displays can be set at I11: DISP OUT2, I12: DISP OUT3, and I13: DISP OUT4 for cyclic display in the order of the parameter number.

**c. User Setting of Engineering Unit and Scale  
(I30: ENGR.UNIT, I31: EASY EU SET, I33: ENGR.LRV, and I34: ENGR.URV)**

These parameters allow the entry of the engineering units and scale to be displayed. The engineering unit can be selected from the parameter of I31: EASY EU SET as listed below. Alternately, up to eight alphanumeric, spaces, and a slash “/” can be input on keypad at I30: ENGR.UNIT; only first six are displayed on the integral indicator.

Select the unit from the list of I31: EASY EU SET.

|       |         |         |
|-------|---------|---------|
| kPa   | ftH2O   | Nl/min  |
| MPa   | gf/cm2  | Nm3/h   |
| mbar  | kgf/cm2 | Nm3/min |
| bar   | kg/cm2G | ACFH    |
| psi   | kg/cm2A | ACFM    |
| psia  | atm     | SCFH    |
| mmH2O | kg/h    | SCFM    |
| mmHg  | t/h     | GPH     |
| mmHgA | m3/h    | GPM     |
| mmAq  | m3/min  | m       |
| mmWG  | l/h     | mm      |
| Torr  | l/min   | in      |
| inH2O | kl/h    | ft      |
| inHg  | kl/min  | kg/m3   |
| inHgA | Nl/h    | g/cm3   |

FX0302.EPS

Follow the procedure below to change the settings.

- Example: Set an engineering unit **M**.

Set **M**.

Press the key twice to enter the setting.

Press the (OK) key.

F0319.EPS

Note that following symbols are not available.

. - , + \* ) ( ' & % \$ # " !

The transmitter integral indicator shows “-----” when these are entered.

- Example: Set lower range value (LRV) to **-50** and upper range value (URV) to **50**.

**Setting LRV**

Set **-50**.

Press the key twice to enter the setting.

Press the (OK) key.

**Setting URV**

Set **50**.

Press the key twice to enter the setting.

Press the (OK) key.

F0320.EPS

**d. Setting Static Pressure Unit and Scale (D30: SP UNIT, D33: SP LRV, and D34: SP URV)**

Static pressure can be displayed in measured input static pressure or in %, independent from the 4-20 mA output signal of measured pressure or differential pressure. These parameters allow the entry of the static pressure unit and scale to be displayed.



Note that the parameter D37: SP SELECT can be used to select either the high or low pressure side of the capsule to monitor the static pressure.

**(7) Unit Setup for Displayed Temperature (D40: TEMP UNIT)**

When the instrument is shipped, the temperature units are set to **degC**. Follow the procedure below to change this setting. Note that changing the unit here changes the unit for A30: CAPSULE TEMP (capsule temperature) and J45: AMP TEMP (amplifier temperature).

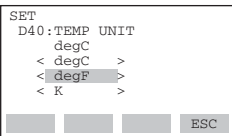
• Example: Change the unit for the temperature display **degC** to **degF**.



Use the  or  key to select **degF**.

Press the  key twice to enter the setting.

Then press the  (OK) key.



F0321.EPS

**(8) Operation Mode Setup (D22: REV OUTPUT)**

This parameter allows the direction of the 4-20 mA output to be reversed with respect to input. Follow the procedure below to make this change.

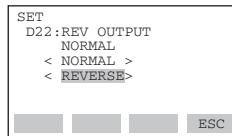
• Example: Change 4 to 20 mA output to 20 to 4 mA output.



Use the  or  key to select **REVERSE**.

Press the  key twice to enter the setting.

Then press the  (OK) key.



F0322.EPS

**(9) Impulse Line Connection Orientation Setup (D15: H/L SWAP)**

This function reverses the impulse line orientation. Follow the procedure below to make this change.

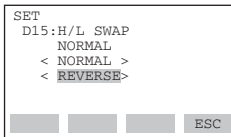
• Example: Assign the high pressure impulse line connection to the L side of the transmitter.



Use the  or  key to select **REVERSE**.

Press the  key twice to enter the setting.



Then press the  (OK) key.

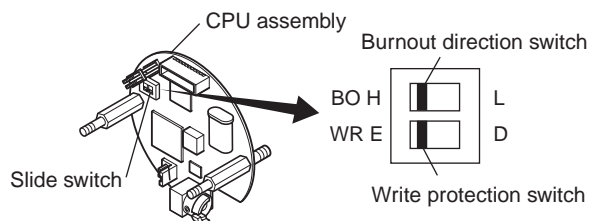

F0323.EPS

**(10) CPU Failure Burnout Direction and Hardware Write Protect (D25: BURNOUT)**

There are two slide switches on the CPU assembly board. One sets the burnout direction at CPU failure, and the other sets a write protection function which disables parameter changes through the use of a handheld terminal or some other communication method.



| Burnout direction switch (BO)     |   |   |   |
|-----------------------------------|---|---|---|
| Burnout Direction Switch Position | H  L | H  L | L  D |
| Burnout Direction                 | HIGH  | LOW   |   |

| Hardware write protection switch (WR) |   |   |   |
|---------------------------------------|---|---|---|
| Write Protection Switch Position      | H  L | H  L | L  D |
| Write Protection                      | NO (Write enabled)  | YES (Write disabled)  |   |

F0324.EPS

The parameter of D25: BURNOUT displays the status of 4-20 mA DC output if a CPU failure occurs. In case of a failure, communication is disabled.

Standard specifications

The burnout direction switch is set to HIGH. If a failure occurs, the transmitter outputs a 110% or higher signal.

Option code /C1

The burnout direction switch is set to LOW. If a failure occurs, a -5% or lower output is generated.

- Example: Standard specifications

D25: BURNOUT  
HIGH

Slide switch position: H

- Example: Option code /C1

D25: BURNOUT  
LOW

Slide switch position: L

F0325.EPS

**(11) Software Write Protect (D55: WRT PROTECT, D56: WRT ENABLE, D57: NEW PASSWORD)**

EJX configured data can be saved by the write protect function. Write protect status (D55: WRT PROTECT) is set from **NO** to **YES** when eight alphanumeric characters are entered in the parameter of D57: NEW PASSWORD. Accordingly, the transmitter does not accept any parameter changes. When the eight alphanumeric password is entered in the parameter of D56: WRT ENABLE, the transmitter accepts parameter changes during a 10 minute period.

To cancel the transmitter for the software write protection completely, use D56: WRT ENABLE to first release the write protect function and then enter eight spaces in the D57: NEW PASSWORD field.

The software write protection does not affect the function of external zero adjustment screw.

To disable the external zero adjustment screw, set the parameter of J15: EXT ZERO ADJ to INHIBIT before activating the software write protection.

**a. Setting Password (D57: NEW PASSWORD)**

- Example: Set the password to 1234ABCD.

Enter **1234ABCD**.

Press the **ENTER** key twice to enter the setting.

Press the **F4** (OK) key.

Then status of parameter D55: WRT PROTECT becomes YES.

F0340.EPS

**b. Entering Password to Enable Parameter Change (D56: WRT ENABLE)**

- Example: Enter the password of 1234ABCD.

Enter the password.

Press the **ENTER** key twice to enter the setting.

Press the **F4** (OK) key.

Parameter changes are available for 10 minutes.

F0341.EPS

**c. Releasing Password (D57: NEW PASSWORD)**

To release the password, enter eight spaces at D57: NEW PASSWORD during the period that the parameter change is possible.

**d. Software Seal (D58: SOFTWR SEAL)**

When you lose the password that has been registered, it is possible to release the write protect function by using general password, "YOKOGAWA." When the password is used, the status shown in the parameter of D58: SOFTWR SEAL is changed from **KEEP** to **BREAK**. The status returns to **KEEP** by entering a newly set password at D56: WRT ENABLE.

**(12) Output Status Setup when a Hardware Error Occurs (D26: ERROR OUT)**

This parameter allows the setting of the output status when a hardware error occurs. The following selections are available.

- (a) BURNOUT DIR; Outputs the corresponding values of 110% or -5% of output signals according to the setting by burnout direction switch (BO) on the CPU board.
- (b) HOLD; Outputs the last value held before the error occurred.

Note: A hardware error means CAP.ERR of AL.01 or AMP.ERR of AL.02 which are shown in table 4.2 Alarm Message Summary.

● Example: Set the output status to **HOLD** when a hardware error occurs.

```

SET
D26:ERROR OUT
  BURNOUT DIR
< BURNOUT DIR >
< HOLD >
          
```

Use the or key to select **HOLD**.

Press the **ENTER** key twice to enter the setting.

Then press the **F4** (OK) key.

F0326.EPS

**(13) Bi-directional Flow Measurement Setup (E30: BI DIRE MODE)**

- (a) This parameter enables selection of 50% output at an input of 0 kPa. Procedure is shown in the figure below.
- (b) Combining this with **C40: OUTPUT MODE** provides a square root output computed independently for 0% to 50% output and for 50% to 100% output.

● Example: If measurement range is 0 to 10 kPa (LRV=0 kPa, URV=10 kPa)

```

SET
E30:BI DIRE MODE
  OFF
< OFF >
< ON >
          
```

Use the or key to select **ON**.

Press the **ENTER** key twice to enter the setting.

Then press the **F4** (OK) key.

The measurement range changes to -10 to 0 to 10 kPa (output 0% to 50% to 100).

Note that **C21: PRES LRV** and **C22: PRES URV** are not changed.

F0327.EPS

● Output mode "LINEAR"

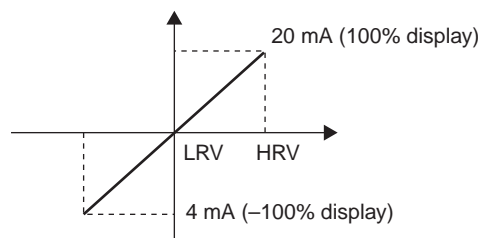

● Output mode "SQUARE ROOT"

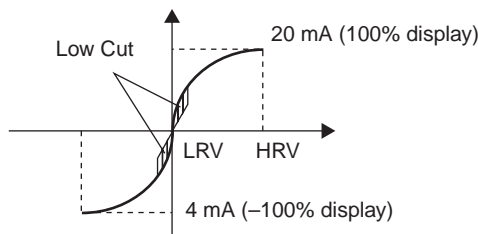

F0328.EPS

**(14) Range Change while Applying Actual Inputs (H10: AUTO P LRV, H11: AUTO P URV)**

This feature allows the lower and upper range values to be set up automatically with the actual input applied. If the lower and upper range values are set, C21: PRES LRV and C22: PRES URV are changed at this same time.

Follow the procedure in the figure below.

The measurement span is determined by the upper and lower range values. Changing the lower range value results in the upper range value changing automatically, keeping the span constant.

● Example 1: When changing the lower range value to 0.5 kPa for the present setting of 0 to 30 kPa, take the following action with input pressure of 0.5 kPa applied.

```

SET
H10:AUTO P LRV
  0 kPa
+ 0
          
```

Press the **ENTER** key twice.

The lower range value is changed to 0.5 kPa.

```

SET
H10:AUTO P LRV
  0.5000 kPa
          
```

Press the **F4** (OK) key.

```

PARAM
H10:AUTO P LRV
  0.5000 kPa
H11:AUTO P URV
  30.500 kPa
H20:AUTO SP LRV
  0.0 MPa
DATA  DIAG  PRINT  ESC
          
```

The upper range value is changed keeping the span constant.

Parameters **C21** and **C22** are changed at the same time.

F0329.EPS

Note that changing the upper range value does not cause the lower range value to change but does change the span.

- Example 2: When the upper range value is to be changed to 10 kPa with the present setting of 0 to 30 kPa, take the following action with an input pressure of 10 kPa applied.

```

SET
H11:AUTO P URV
      30 kPa
+-----+
      30
-----+
          ESC
    
```

Press the **ENTER** key twice.  
The upper range value is changed to 10 kPa.

```

SET
H11:AUTO URV
      10.000 kPa
-----+
          FEED NO OK
    
```

Press the **F4** (OK) key.

```

PARAM
H10:AUTO P LRV
      0 kPa
H11:AUTO P URV
      10.000 kPa
H20:AUTO SP LRV
      0.0 MPa
-----+
          DATA DIAG PRNT ESC
    
```

The lower range value is not changed, so the span changes. Parameter **C22** is changed at the same time.

F0330.EPS

### (15) Sensor Trim

Each DPharp EJX series transmitter is factory characterized. Factory characterization is the process of comparing a known pressure input with the output of each transmitter sensor module over the entire pressure and temperature operating range. During the characterization process, this comparison information is stored in the transmitter EEPROM. In operation, the transmitter uses this factory-stored curve to produce a process variable output (PV), in engineering units, dependent on the pressure input.

The sensor trim procedure allows you to adjust for local conditions, changing how the transmitter calculates process variables. There are two ways to trim the sensor: a zero trim and a full sensor trim. A zero trim is a one-point adjustment typically used to compensate for mounting position effects or zero shifts caused by static pressure. A full sensor trim is a two-point process, in which two accurate end-point pressures are applied (equal to or greater than the range values), and all output is linearized between them.

#### a. Zero Trim (J11: P ZERO ADJ, J15: P ZERO DEV, J55: EXT ZERO ADJ)

The DPharp supports several adjustment methods. Select the method best suited for the conditions of your application.

| Adjustment Method                        | Description  |
|--|--|
| Using the BT200                          | <b>Set the present input to 0%.</b><br>Adjust for 0% output at input level of 0%.  |
|  | <b>Adjust output to the reference value obtained using other means.</b><br>If the input level cannot easily be made 0% (because of tank level, etc.), adjust output to the reference value obtained using other means, such as a sight glass.                    |
| Using the external zero-adjustment screw | Adjust zero point using the zero-adjustment screw on the transmitter. This permits zero adjustment without using the BT200. Accurately adjust the output current to 4 mA DC or other target output value using an ammeter that accurately reads output currents. |

T0307.EPS

When using BT200, the output signal can be adjusted either in % or pressure unit. The unit can be selected by the parameter J09: ADJ UNIT. Output signal can be changed by displaying parameter A10: OUTPUT for % or J10: OUTPUT for pressure unit.

This section describes the zero adjustment procedure by using the pressure unit.

### a-1. Zeroing

Setting the parameter of J11: P ZERO ADJ carries out the zero adjustment and automatically sets the applied "0" input values to the transmitter's output value of zero, keeping the span constant. Use this setting when the LRV is known to be 0 kPa.

|  |  |
|--|--|
| A11: PRES<br>0.03585 kPa                     | Transmitter measures pressure of 0.03585 kPa.  |
| SET<br>J11: P ZERO ADJ<br>0.00000 kPa<br>+ 0 | A pressure of 0 kPa is applied. Press the <b>ENTER</b> key twice after the pressure has become stable. |
| SET<br>J11: P ZERO ADJ<br>0.00000 kPa        | Zero adjustment is completed. Press the <b>F4</b> (OK) key.  |
| A11: PRES<br>0.00000 kPa                     | Transmitter measures pressure of 0.00000 kPa.  |

F0331.EPS

### a-2. Level Adjustment

The zero adjustment by the parameter of J11: P ZERO ADJ calibrates the transmitter output corresponding to the actual tank level. To perform this adjustment, first use a glass gauge or the like to determine the actual tank level, then enter the correct data as shown below.

DPharp span: 0 to 25.00 kPa  
Actual level: 13.50 kPa  
Transmitter output: 13.83 kPa

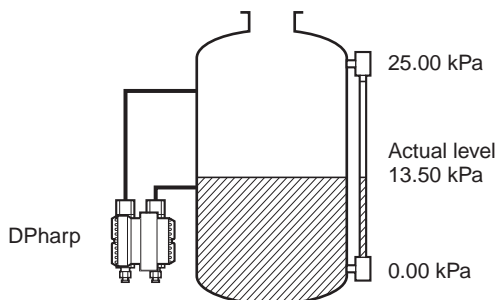

F0332.EPS

|  |   |
|--|---|
| A11: PRES<br>13.83 kPa                                     | Transmitter measures present pressure of 13.83 kPa.                         |
| SET<br>J11: P ZERO ADJ<br>0.00000 kPa<br>+ 045.0<br>+ 13.5 | Enter the present actual level, 13.5 kPa. Press the <b>ENTER</b> key twice. |
| A11: PRES<br>13.5000 kPa                                   | The measured pressure is changed to 13.5 kPa.                               |

F0333.EPS

### a-3. Using External Zero-adjustment Screw

This method permits zero adjustment without the BT200. Use a slotted screwdriver to turn the zero-adjustment screw. See the hardware manual for details.

Note that the parameter of J55: EXT ZERO ADJ must be **ENABLE** to perform this adjustment.

Follow the procedure below to enable or inhibit zero point adjustment from the zero-adjustment screw on the transmitter.

This is set to **ENABLE** when the instrument is shipped.

- Example: Inhibiting zero adjustment by the external zero-adjustment screw.

|   |   |
|---|---|
| SET<br>J55: EXT ZERO ADJ<br>ENABLE<br>< ENABLE ><br>< INHIBIT > | Use the <b>▲</b> or <b>▼</b> key to select <b>INHIBIT</b> . Press the <b>ENTER</b> key twice to enter the setting. Then press the <b>F4</b> (OK) key. |
|---|---|

F0335.EPS

### b. Full Sensor Trim (J11: P ZERO ADJ, J12: P SPAN ADJ, J15: P ZERO DEV, J16: P SPAN DEV)

Full sensor trim is carried out with a series of the procedure of J11: P ZERO ADJ and J12: P SPAN ADJ. Also, you can manually perform the trimming procedure by using J15: P ZERO DEV and J16: P SPAN DEV.

The full sensor trim is a two-point adjustment, and the lower point adjustment should always be performed before the upper point adjustment in order to maintain the pitch between the zero and 100% points within the calibration range.

In the manual method, the reference pressure should also be applied to the transmitter at both lower and upper point of trim ends. Without the reference pressure, J15: P ZERO DEV and J16: P SPAN DEV may not represent the correct value of adjustment point for each.



### c. Sensor Trim for Static Pressure (J21: SP ZERO ADJ, J22: SP SPAN ADJ, J25: SP ZERO DEV, J26: SP SPAN DEV)



For the EJX differential transmitters (Except for EJX120A), zeroing and full sensor trim of the static pressure is performed in the same way as with the primary process variable (PV). Note that the static pressure sensor trim should be done only after trimming the PV.

### d. Reset Trim Adjustment to Factory Setting (J56: CLEAR ADJ)

Use **PRES** or **SP** of J56: CLEAR ADJ parameter to reset the trim adjustment to the initial calibrated values that were set. When **PRES** is selected to clear the adjustment, the amount of the adjustment by the external zero-adjustment screw is returned to the initial setting as well.

• Example: Reset the trim adjustment of pressure to factory set characterization curve.

```
SET
J56: CLEAR ADJ
---
< --- >
< PRES >
< SP >
< 4-20mA >
```

Use the  or  key to select **PRES**.

Press the  key twice to enter the setting.

```
SET
J56: CLEAR ADJ
---
```

Press the  (OK) key.

```
FEED NO OK
```

F0353.EPS

### (16) Test Output Setup (K10: OUTPUT X %)

This feature can be used to output a fixed current for loop checks. The available range for test output depends on the setting at parameters of D20 OUT LIMIT (L) and D21 OUT LIMIT (H), whose limit is from 3.6 mA (-2.5%) to 21.6 mA (110%).

- Example: Output 12 mA (50%) fixed current.

```
SET
K10: OUTPUT X %
0.00 %
+ 050.00
```

Set **50.00%**.

Press the  key twice to output a fixed current at 50%.

```
SET
K10: OUTPUT X %
50.00% ACTIVE
```

**Active** is displayed while this is being executed.

Press the  (OK) key to cancel the fixed current output.

F0336.EPS



### IMPORTANT

1. Test output continues for approximately 10 minutes, then is released automatically. Even if the BT200 power supply is turned off or the communication cable is disconnected, test output will continue for approximately 10 minutes.
2. Press the  (OK) key to release test output immediately.

### (17) Signal Characterizer

This function is used to compensate the output for non-linear applications. The characterized values are applied to the 4-20 mA output. For the measured pressure, a maximum of nine coordinates can be specified between 0-100%. Perform the coordinate settings while the T10: S. C. ENABLE parameter is **INHIBIT**.

To apply the settings to the output, set the T10: S. C. ENABLE parameter to **ENABLE**.

Note that the EJX rejects the activation of the function by AL. 60 with the following transmitter's status:

- When the specified coordinates of x and y are not incremental as the input increases.
- When the output mode of the output signal is set as **SQUARE ROOT**; at the same time, the low cut mode is set to **LINEAR**.

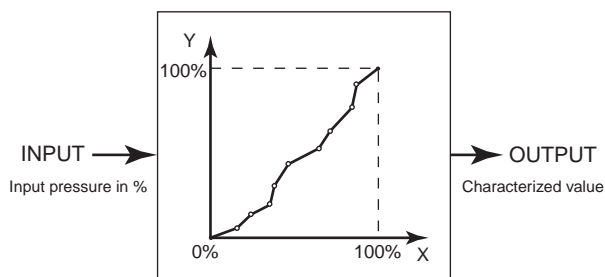

F0342.EPS

• Example: Set the number of coordinates on the line graph to 5.

SET  
T11:NUM OF POINT  
9  
5

CLR ESC

Set 5.  
Press the **ENTER** key twice to enter the setting.

SET  
T11:NUM OF POINT  
5

FEED NO OK

Press the **F4** (OK) key.

F0344.EPS

**(18) Process Alarm (G10: P AL MODE, G11: P HI.AL VAL, G12: P LO.AL.VAL)**

The function is used to display the alarm codes when the input pressure exceeds the specified value within the calibration range. The same is available for the input static pressure and the capsule temperature on the pressure sensor. Refer to table 4.2 Alarm Message Summary for the specific alarm code to be generated.

• Example: Set alarm mode from **OFF** to **HI.AL DETECT**.

SET  
G10:P AL MODE  
INHIBIT  
< INHIBIT >  
< HI.AL DETECT >  
< LO.AL DETECT >  
< HI/LO.AL DETECT >

ESC

Use the or key to select **HI.AL DETECT**.  
Press the **ENTER** key twice to enter the setting.

SET  
G10:P AL MODE  
HI.AL DETECT

FEED NO ESC

Press the **F4** (OK) key.  
Alarm code is generated when the output goes beyond the value set at G11: P HI. AL VAL.

F0346.EPS

• Example: Set the first coordinates (X1, Y1) as (12, 14) in %.

SET  
T22:X1  
10.00%  
+ 012.00

CLR ESC

Set 12 for X1.  
Press the **ENTER** key twice to enter the setting.  
Press the **F4** (OK) key.

SET  
T23:Y1  
10.00%  
+ 014.00

CLR ESC

Set 14 for Y1.  
Press the **ENTER** key twice to enter the setting.  
Press the **F4** (OK) key.

PARAM  
T21:Y 0.00%  
T22:X1 12.00%  
T23:Y1 14.00%

DATA DIAG PRNT ESC

F0345.EPS

• Example: Set the higher alert value of 75 for alarm generation.

SET  
G11:P HI.AL VAL  
100.000 kPa  
+ 75

CODE CAPS CLR ESC

Set 75.  
Press the **ENTER** key twice to enter the setting.

SET  
G11:P HI.AL VAL  
75.0000 kPa

FEED NO OK

Press the **F4** (OK) key.  
Then the alarm code "AL.35 P. HI" is generated when the input pressure goes beyond that value.

F0347.EPS

• Example: Set the signal characterizer **ENABLE**.

SET  
T10:S.C.ENABLE  
INHIBIT  
< INHIBIT >  
< ENABLE >

ESC

Use the or key to select **ENABLE**.  
Press the **ENTER** key twice to activate the function.

SET  
T10:S.C.ENABLE  
ENABLE

FEED NO OK

Press the **F4** (OK) key.

F0343.EPS

**(19) Status Output (option code AL)**

This feature is used for a transistor output (open collector) of an on/off signal according to the status of high and low alarm limits, which are user-configurable values as shown in (18) Process Alarm. The status output can be assigned as any combination of the high or low limits of the input pressure, input static pressure, or capsule temperature.

**CAUTION**

Execute DO testing by the parameter "K40 DO test" whenever turning on the transmitter or detecting the short interruption in order to check that the alarm contact output is correctly configured.



**NOTE**

No status output signal has been defined for a CPU failure or hardware error. Use a 4-20 mA signal to indicate a transmitter's failure.

- Example: Set the status output to output an off signal when the input pressure exceeds 75 kPa with its alert mode of HI. AL DETECT.

```
SET
E50:DO SELECT
  INHIBIT
< INHIBIT >
  PRES
< SP >
< TEMP >
ESC
```

Use the or key to select **PRES**.

Press the **ENTER** key twice to enter the setting.

```
SET
E50:DO SELECT
  PRES
FEED NO OK
```

Press the **F4** (OK) key.

```
SET
E51:DO SIG.TYPE
  ON WHEN ALARM
< ON WHEN ALARM >
  OFF WHEN ALARM
ESC
```

Use the or key to select **OFF WHEN ALARM**.

Press the **ENTER** key twice to enter the setting.

```
SET
E51:DO SIG.TYPE
  OFF WHEN ALARM
FEED NO OK
```

Press the **F4** (OK) key.

F0354.EPS

Example: Status output operation of **ON WHEN AL. DETECT**

- Status output for higher alert value

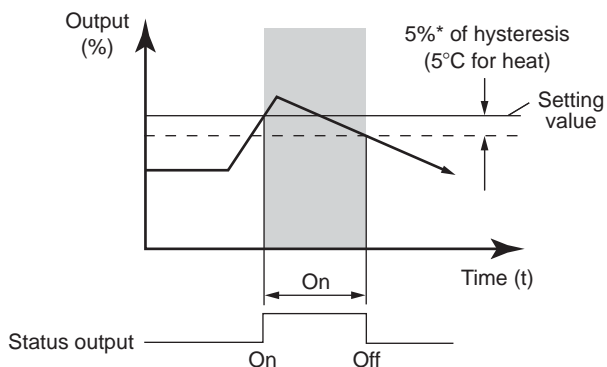

- Status output for lower alert value

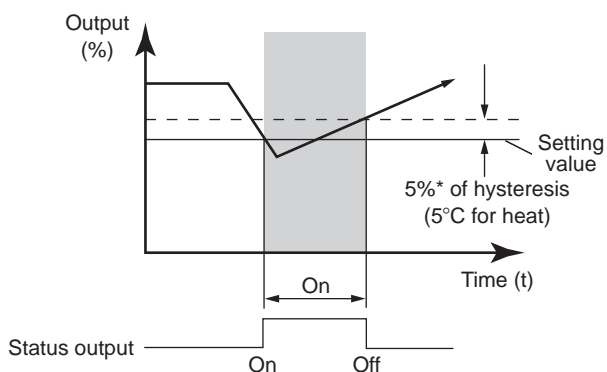

F0350.EPS

\*5% of the setting span of differential pressure / pressure.

**(20) Capillary Fill Fluid Density Compensation (E10: T.ZERO CMP, E11: TEMP ZERO)**

For transmitters with diaphragm seals, this function is used to compensate the zero shift caused by the ambient temperature effect on the capillary tubes.

The following equation indicates the relationship between the calculated output value and the compensating constant K (%/°C) with the measured ambient temperature at the capsule module.

$$\text{Compensated output} = \text{output} + K \times T_{\text{amb}}$$

**(1) Temperature Compensation Mode Setup (E10: T. ZERO CMP)**

When using this function, set T. ZERO CMP to *ON* to enable or *OFF* to disable. To set to *ON*, follow the procedure below.

• Example: Set the temperature compensation mode to **ON**.

```

SET
E10:T.ZERO CMP
OFF
< OFF >
< ON >
        
```

Use the or key to select **ON**.

Press the key twice to enter the setting.

```

SET
E10:T.ZERO CMP
ON
        
```

Press the (OK) key.

F0355.EPS

**(2) Zero Shift Compensation Setup (E11: TEMP ZERO)**

Obtain the K compensating value from the equation(1) below.

$$K = - \frac{h \times B}{\text{Span}} \times 100 \dots \dots \dots (a)$$

where,

B: Constant value of fill fluid (See Table A.)

span: |URV-LRV|

h: Distance from high pressure side to low pressure side (m)

EJX118A: Distance from high side of diaphragm seal to low side of diaphragm seal.

EJX438A: Distance from diaphragm seal (high side) to position of transmitter (low side).

● EJX118A

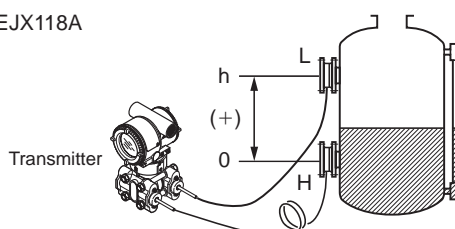

● EJX438A

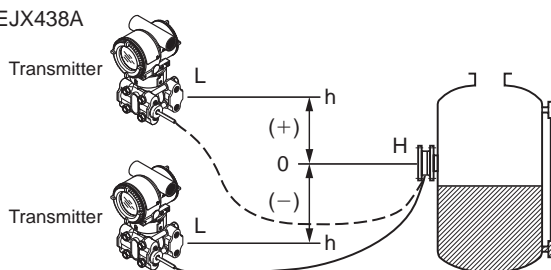

Note: When the transmitter is positioned lower than the diaphragm seal part, the value of "h" must have a negative sign (-).

F0357.EPS

• Example: Enter K value obtained from the equation (a). A value having up to 3 decimal places may be specified.

When h = +3 m, Fill fluid code A, span = 15 kPa,  
 $K = -(+3) \times 0.00745 \div 15 \times 100 = -0.149$

```

SET
E11:TEMP ZERO
0.000 %/degC
- 00.149
        
```

Enter "-0.149."

Press the key twice to enter the setting.

```

SET
E11:TEMP ZERO
-0.149 %/degC
        
```

Press the (OK) key.

F0358.EPS

Note 1: The function is performed using a built-in temperature sensor in the transmitter body. The temperature deviation between the transmitter body and capillaries should be minimized to achieve optimal performance of the function.

Note 2: When the span changes, reenter the newly obtained value of K to E11: TEMP ZERO.

**Table A. Constant value [B] of fill fluid**

|                    | Fill fluid code     | A, C     | B        | D        | E        |
|--------------------|---------------------|----------|----------|----------|----------|
| Constant value [B] | mmH <sub>2</sub> O  | 0.76     | 0.87     | 1.45     | 0.75     |
|                    | kgf/cm <sup>2</sup> | 0.000076 | 0.000087 | 0.000145 | 0.000075 |
|                    | kPa                 | 0.00745  | 0.00853  | 0.01422  | 0.00736  |
|                    | mBar                | 0.07453  | 0.08532  | 0.14220  | 0.07355  |
|                    | atm                 | 0.000074 | 0.000084 | 0.000140 | 0.000073 |
|                    | inH <sub>2</sub> O  | 0.02992  | 0.03425  | 0.05709  | 0.02953  |
|                    | psi                 | 0.00108  | 0.00124  | 0.00206  | 0.00167  |
|                    | mmHg                | 0.05592  | 0.06401  | 0.10669  | 0.05518  |

T0308.EPS

Note 3: Select the unit of constant value of [B] from the actual unit used for the transmitter in operation.

**(21) Adjustment Information and User Memo Fields (J50: ADJ WHO, J51: ADJ DATE, J52: ADJ LOC, J53: ADJ DESC, M17 to M19: MEMO1 to MEMO3)**

This feature provides four fields for instrument adjustment information at maintenance: inspection date, inspector, location, and description. Also three user memo fields are provided, each holding up to 16 alphanumeric characters.

- Example: Save an inspection date of October 21, 2003.

|   |  |
|---|--|
| PARAM<br>J50:ADJ WHO<br>J51:ADJ DATE<br>J52:ADJ LOC<br>DATA DIAG PRNT ESC | Set "10-21-2003" in the order of month, day, and year. |
| SET<br>J51:ADJ DATE<br>MM-DD-YYYY<br>10-21-2003<br>CODE CAPS CLR ESC      | Press the <b>ENTER</b> key twice to enter the setting. |

F0337.EPS

### 3.3 Displaying Data Using the BT200

#### 3.3.1 Displaying Measured Data

The BT200 can be used to display measured data.

The measured data is updated automatically every seven seconds. In addition, the display can be updated to the present data value at any time by pressing the **F1** (DATA) key. For parameters associated with the display of measured data, see chapter 5 Parameter Summary.

- Example: Display output.

|   |   |
|---|---|
| MENU<br>A: DISPLAY<br>B: SENSOR TYPE<br>C: BASIC SETUP<br>D: AUX SET1<br>E: AUX SET2<br>G: ALARM SET<br>HOME SET ADJ ESC          |   |
| PARAM<br>A10: OUTPUT<br>0.0 % ←<br>A11: PRES<br>0.0000 kPa ←<br>A15: OUTPUT mA<br>4.000 mA ←<br>DATA DIAG PRNT ESC                | Display "A10: OUTPUT"<br><br>Data is updated automatically at 7-second intervals. |
| PARAM <span style="float: right;">communi</span><br>A10: OUTPUT<br>0.0 %<br>A11: PRES<br>0.0000 kPa<br>A15: OUTPUT mA<br>4.000 mA |   |

F0338.EPS

#### 3.3.2 Display Transmitter Model and Specifications

The BT200 can be used to display the model and specifications of the transmitter.

- Example: View transmitter model name.

|  |  |
|--|--|
| MENU<br>A: DISPLAY<br>B: SENSOR TYPE<br>C: BASIC SETUP<br>D: AUX SET1<br>E: AUX SET2<br>G: ALARM SET<br>HOME SET ADJ ESC | Press <b>ENTER</b> .   |
| ↓  |  |
| PARAM<br>B10: MODEL<br>EJX110 M<br>B11: STYLE NO.<br>1.00<br>B20: PRES LRL<br>- 98.07 kPa<br>DATA DIAG PRNT ESC          | For the associated parameters, see Chapter 5, Parameter Summary. |

F0339.EPS

# 4. SELF-DIAGNOSTICS

## 4.1 Checking for Problems

### 4.1.1 Identifying Problems with BT200

The following four areas can be checked.

- Whether connections are good.
- Whether BT200 was properly operated.
- Whether settings were properly entered.
- History of the errors.

See examples below.

#### • Example 1: Connection errors

```
--WELCOME--
BRAIN TERMINAL
ID: BT200

check connection
push ENTER key

UTIL FEED
```

Press the **ON/OFF** key.  
When the panel shown on the left appears, press the **ENTER** key.

```
communication error

ESC
```

Since communications will be unsuccessful if there is a problem in the connection to the BT200, the display at the left will appear.  
Recheck the connection.  
Press the **F4** (OK) key.

#### • Example 2: Setting entry errors

```
PARAM
01:MODEL
EJX110 M
02:TAG NO.
YOKOGAWA
03:SELF CHECK
ERROR

OK
```

The initial data panel shows the result of current transmitter diagnostics.

```
PARAM
C20: PRES UNIT
kPa
C21: PRES LRV
600 kPa
C22: PRES URV
600 kPa

DATA DIAG PRNT ESC
```

Press the **F2** (DIAG) key in the parameter panel to go to the diagnostics panel (C60: SELF CHECK).

```
DIAG
C60: SELF CHECK
ERROR
< ERROR >
< ILLEGAL LRV >

FEED PRNT ESC
```

An error message is displayed when an error occurs in the diagnostics panel.

F0401.EPS

#### • Example 3: Checking the history of the errors

```
MENU
J:ADJUST
K:TEST
L:CALIBRATION
M:MEMO
P:RECORD
T:CHARACTERIZR
HOME SET ADJ ESC
```

Connect the BT200 to the transmitter, and call item "P"

```
PARAM
P10:ERROR REC 1
ERROR
P12:ERROR REC 2
ERROR
P14:ERROR REC 3
GOOD
DATA DIAG PRNT ESC
```

P10: "ERROR REC 1" displays the last error.

P12: "ERROR REC 2" displays the error one time before the last error occurred.

P14: "ERROR REC 3" displays the error two times before the last error occurred.

P16: "ERROR REC 4" displays the error three times before the last error occurred.

The history of up to four errors can be stored. When the 5th error has occurred, it is stored in "P10." The error stored in "P16" will be deleted, and then, the error in "P14" will be copied to "P16." In this sequence, the history of the most previously occurred error will be removed from memory. "GOOD" will be displayed if there was no previous error.

```
SET
P10:ERROR REC 1
ERROR
< ERROR >
<50:P ILLEG LRV >

ESC
```

Select P10: ERROR REC1 and press the **ENTER** key to display the error message.

<(a) SETUP PANEL>

For the details of the messages, see [Table 4.5.1 Alarm Message Summary](#).

Note 1: Press the **ENTER** key twice in the setup panel (a) to clear all error message (P10 to P16) information.

Note 2: When the error occurs, the self-diagnostic detects errors and records them in two ways depending on the types of errors. The amplifier/capsule failures are recorded immediately after the occurrence, while the minor errors such as warnings of inappropriate parameter settings are periodically recorded at an interval of minimum five minutes to twenty four hours. Note that the interval extends as the number of access counts to EEPROM increases.

F0402.EPS

### 4.1.2 Checking with Integral Indicator

**NOTE**

If an error is detected by running self-diagnostics, an error number is displayed on the integral indicator. If there is more than one error, the error number changes at three-second intervals. See table 4.2 regarding the alarm codes.



F0403.EPS

Figure 8.5.1 Integral Indicator

## 4.2 Alarms and Countermeasures

Table 4.2 Alarm Message Summary

| Indicator          | BT200 display     | Cause  | Output operation during error   | Countermeasure  |
|--------------------|-------------------|--|---|---|
| None               | GOOD              |  |   |   |
| AL. 01<br>CAP. ERR | 01: P-SENSOR ERR  | Sensor problem.  | Outputs the signal (Hi or Low) set with parameter D26. [Status output: undefined] | Replace capsule when error keep appearing error even after restart.   |
|                    | 01: CT-SENSOR ERR | Capsule temperature sensor problem.                      |   | Replace capsule.  |
|                    | 01: C-EEPROM ERR  | Capsule EEPROM problem.                                  |   |   |
| AL. 02<br>AMP. ERR | 02: AT-SENSOR ERR | Amplifier temperature sensor problem.                    |   | Replace amplifier.  |
|                    | 02: A-EEPROM ERR  | Amplifier EEPROM problem.                                |   |   |
|                    | 02: CPU BOARD ERR | Amplifier problem.                                       |   |   |
| AL. 10<br>PRESS    | 10: P OVER SPEC   | Input is outside measurement range limit of capsule.     | Outputs upper range limit (URL) or lower range limit (LRL).                       | Check input or replace capsule when necessary.                        |
| AL. 11<br>ST. PRSS | 11: SP OVER SPEC  | Static pressure exceeds limit.                           | Continues to operate and output.  |   |
| AL. 12<br>CAP. TMP | 12: CT OVER SPEC  | Capsule temperature is outside range (-50 to 130°C).     |   | Use heat insulation or make lagging to keep temperature within range. |
| AL. 13<br>AMP. TMP | 13: AT OVER SPEC  | Amplifier temperature is outside range (-50 to 95°C).    |   |   |
| AL. 30<br>RANGE    | 30: P OVER RANGE  | Output is outside upper or lower range limit value.      | Outputs upper range value (URV) or lower range value (LRV).                       | Check input and range setting, and change them as needed.             |
| AL. 31<br>SP. RNG  | 31: SP OVER RANGE | Static pressure exceeds specified range.                 | Continues to operate and output.  |   |
| AL. 35<br>P. HI    | 35: P HIGH ALARM  | Input pressure exceeds specified threshold.              |   | Check input.  |
| AL. 36<br>P. LO    | 36: P LOW ALARM   |  |   |   |
| AL. 37<br>SP. HI   | 37: SP HIGH ALARM |  |   |   |
| AL. 38<br>SP. LO   | 38: SP LOW ALARM  |  |   |   |
| AL. 39<br>TMP. HI  | 39: CT HIGH ALARM | Detected temperature exceeds specified threshold.        |   | Check capsule temperature.  |
| AL. 40<br>TMP. LO  | 40: CT LOW ALARM  |  |   |   |
| AL. 50<br>P. LRV   | 50: P ILLEG LRV   | Specified value is outside of setting range.             | Holds output immediately before error occurred.                                   | Check settings and change them as needed.                             |
| AL. 51<br>P. URV   | 51: P ILLEG URV   |  |   |   |
| AL. 52<br>P. SPN   | 52: P ILLEG SPAN  |  |   |   |
| AL. 53<br>P. ADJ   | 53: P SPAN ADJ    |  | Continues to operate and output.  | Adjust settings and change them as needed.                            |
|                    | 53: P ZERO ADJ    |  |   |   |
| AL. 54<br>SP. RNG  | 54: SP ILLEG LRV  |  | Continues to operate and output holding static pressure in %.                     | Check settings and change them as needed.                             |
|                    | 54: SP ILLEG URV  |  |   |   |
|                    | 54: SP ILLEG SPAN |  |   |   |
| AL. 55<br>SP. ADJ  | 55: SP SPAN ADJ   |  | Continues to operate and output.  | Adjust settings and change them as needed.                            |
|                    | 55: SP ZERO ADJ   |  |   |   |
| AL. 60<br>SC. CFG  | 60: SC CONFIG ERR | Specified values or settings do not meet the conditions. | Continues to operate and output without signal characterizing.                    | Check settings and change them as needed.                             |
| AL. 79<br>OV. DISP | _____             | Displayed value exceeds limit.                           | Continues to operate and output.  |   |

# 5. PARAMETER SUMMARY

Instruments to which applicable:

F: Differential pressure transmitters

P: Absolute and gauge pressure transmitters

L: Flange mounted differential pressure transmitters

| No. | Parameter name | Item   | R/W <sup>*1</sup> | Content  | Default value            | Applicable model |   |   | Upload data |
|-----|----------------|--|-------------------|--|--------------------------|------------------|---|---|-------------|
|     |                |  |                   |  |                          | F                | P | L |             |
| 01  | MODEL          | Model  | R                 |  | EJX                      | ○                | ○ | ○ | -           |
| 02  | TAG No.        | Tag number                                   | R                 |  | As specified             | ○                | ○ | ○ | -           |
| 03  | SELF CHECK     | Self-diagnostics                             | R                 |  | GOOD                     | ○                | ○ | ○ | -           |
| A   | DISPLAY        | Measured data display                        |                   |  |                          |                  |   |   |             |
| A10 | OUTPUT         | Output (in %)                                | R                 | -2.5 to 110%   |                          | ○                | ○ | ○ | -           |
| A11 | PRES           | Measured pressure after zero adjustment      | R                 | Unit specified in C20  |                          | ○                | ○ | ○ | -           |
| A15 | OUTPUT mA      | Output current                               | R                 | 3.6000 to 21.6000 mA   |                          | ○                | ○ | ○ | -           |
| A16 | ENGR. OUTPUT   | User scaled value                            | R                 | Unit specified in I30  |                          | ○                | ○ | ○ | -           |
| A17 | ENGR. EXP      | Exponents                                    | R                 | Unit specified in I32  |                          | ○                | ○ | ○ | -           |
| A20 | SP %           | Static pressure (in %)                       | R                 | -10 to 110%  |                          | ○                | - | ○ | -           |
| A21 | SP             | Static pressure after zero adjustment        | R                 | Unit specified in D30  |                          | ○                | - | ○ | -           |
| A30 | CAPSULE TEMP   | Capsule temperature                          | R                 | Unit specified in D40  |                          | ○                | ○ | ○ | -           |
| A60 | SELF CHECK     | Self-diagnostics                             | R                 | Refer to Table 4.2 Alarm Message Summary   |                          | ○                | ○ | ○ | -           |
| B   | SENSOR TYPE    | Sensor type                                  |                   |  |                          |                  |   |   |             |
| B10 | MODEL          | Model and capsule type                       | R                 | Model and capsule type   |                          | ○                | ○ | ○ | -           |
| B11 | STYLE NO.      | Style number                                 | R                 | Style number of product  |                          | ○                | ○ | ○ | -           |
| B20 | PRES LRL       | Lower range limit                            | R                 | Unit specified in C20  |                          | ○                | ○ | ○ | -           |
| B21 | PRES URL       | Upper range limit                            | R                 | Unit specified in C20  |                          | ○                | ○ | ○ | -           |
| B22 | P MIN SPAN     | Minimum span                                 | R                 | Unit specified in C20  |                          | ○                | ○ | ○ | -           |
| B30 | SP LRL         | Lower range limit for static pressure        | R                 | Unit specified in D30  |                          | ○                | - | ○ | -           |
| B31 | SP URL         | Upper range limit for static pressure        | R                 | Unit specified in D30  |                          | ○                | - | ○ | -           |
| B32 | SP MIN SPAN    | Minimum span for static pressure             | R                 | Unit specified in D30  |                          | ○                | - | ○ | -           |
| B60 | SELF CHECK     | Self-diagnostics                             | R                 | See A60  |                          | ○                | ○ | ○ | -           |
| C   | BASIC SETUP    | Setting data                                 |                   |  |                          |                  |   |   |             |
| C10 | TAG NO.        | Tag number                                   | W                 | 16 alphanumeric characters   | As specified             | ○                | ○ | ○ | ○           |
| C20 | PRES UNIT      | Measurement range unit                       | W                 | mmH2O, mmAq, mmWG, mmHg, Torr, kPa, MPa, mbar, bar, gf/cm2, kgf/cm2, inH2O, inHg, ftH2O, psi, atm, Pa, hPa | kPa                      | ○                | ○ | ○ | ○           |
| C21 | PRES LRV       | Lower range value                            | W                 | -32000 to 32000 within measurement range   | As specified             | ○                | ○ | ○ | ○           |
| C22 | PRES URV       | Upper range value                            | W                 | -32000 to 32000 within measurement range   | As specified             | ○                | ○ | ○ | ○           |
| C23 | PRES POINT     | Decimal place                                | W                 | 0 to 4   | 2                        | ○                | ○ | ○ | ○           |
| C30 | AMP DAMPING    | Damping time constant at amplifier           | W                 | 0.50 (0.00) to 100.00 sec, see D50   | 2.00 sec or as specified | ○                | ○ | ○ | ○           |
| C40 | OUTPUT MODE    | Output mode                                  | W                 | LINEAR or SQUARE ROOT  | LINEAR or as specified   | ○                | ○ | ○ | ○           |
| C60 | SELF CHECK     | Self-diagnostics                             | R                 | See A60  |                          | ○                | ○ | ○ | -           |
| D   | AUX SET 1      | Auxiliary setting data 1                     |                   |  |                          |                  |   |   |             |
| D10 | LOW CUT        | Low cut                                      | W                 | 0.00 to 20.00%   | 10.00%                   | ○                | ○ | ○ | ○           |
| D11 | LOW CUT MODE   | Low cut mode                                 | W                 | LINEAR or ZERO   | LINEAR                   | ○                | ○ | ○ | ○           |
| D15 | H/L SWAP       | Impulse piping accessing direction           | W                 | NORMAL or REVERSE  | NORMAL                   | ○                | - | ○ | ○           |
| D16 | H2O UNIT SEL   | H2O unit select                              | W                 | @4degC or @20degC (68.0F)  | @4degC                   | ○                | ○ | ○ | ○           |
| D20 | OUT LIMIT (L)  | Low side output limiter                      | W                 | -2.50 to 110.00%   | -2.50%                   | ○                | ○ | ○ | ○           |
| D21 | OUT LIMIT (H)  | High side output limiter                     | W                 | -2.50 to 110.00%   | 110%                     | ○                | ○ | ○ | ○           |
| D22 | REV OUTPUT     | Output reversal                              | W                 | NORMAL or REVERSE  | NORMAL                   | ○                | ○ | ○ | ○           |
| D25 | BURNOUT        | CPU error                                    | R                 | HIGH or LOW  |                          | ○                | ○ | ○ | -           |
| D26 | ERROR OUT      | Hardware error                               | W                 | BURNOUT DIR or HOLD  | BURNOUT DIR              | ○                | ○ | ○ | ○           |
| D30 | SP UNIT        | Static pressure unit                         | W                 | See C20  | MPa                      | ○                | - | ○ | ○           |
| D31 | SP A/G SLCT    | Gauge/Abs select for static pressure         | W                 | GAUGE or ABSOLUTE  | ABSOLUTE                 | ○                | - | ○ | ○           |
| D32 | ATM. PRESS     | Coefficient for given gauge pressure         | W                 | Unit specified in D30  | 0.10133 MPa              | ○                | - | ○ | ○           |
| D33 | SP LRV         | Lower limit of static pressure               | W                 | -32000 to 32000 within measurement range   | 0.0 MPa                  | ○                | - | ○ | ○           |
| D34 | SP URV         | Upper limit of static pressure <sup>*2</sup> | W                 | -32000 to 32000 within measurement range   |                          | ○                | - | ○ | ○           |

\*1: R/W: R = Read only, W = Read & Write

\*2: The default value shows MWP (Maximum working pressure) of the capsule.

Since the working pressure limit varies according to the Model, refer to the General Specifications section in each user's manual.

## 5. PARAMETER SUMMARY

| No. | Parameter name | Item  | R/W <sup>*1</sup> | Content   | Default value | Applicable model |   |   | Upload data |
|-----|----------------|---|-------------------|---|---------------|------------------|---|---|-------------|
|     |                |   |                   |   |               | F                | P | L |             |
| D   | AUX SET 1      | Auxiliary setting data 1                      |                   |   |               |                  |   |   |             |
| D35 | SP POINT       | Decimal place of static pressure              | W                 | 0 to 4  | 1             | ○                | - | ○ | ○           |
| D36 | SP DAMPING     | Damping time constant of SP                   | W                 | 0.00 to 100.00 sec  | 2.00 sec      | ○                | - | ○ | ○           |
| D37 | SP SELECT      | H/L select for static pressure                | W                 | HIGH or LOW   | HIGH          | ○                | - | ○ | ○           |
| D40 | TEMP UNIT      | Temperature setting unit                      | W                 | degC, degF, or K  | degC          | ○                | ○ | ○ | ○           |
| D50 | QUICK RESP     | Quick response                                | W                 | OFF or ON (enable 0.00 to 0.50 sec at C30)                            | OFF           | ○                | ○ | ○ | ○           |
| D55 | WRT PROTECT    | Write protect indicator                       | R                 | NO or YES   | NO            | ○                | ○ | ○ | -           |
| D56 | WRT ENABLE     | Write protect release                         | W                 | 8 alphanumeric characters   | None          | ○                | ○ | ○ | -           |
| D57 | NEW PASSWORD   | User set password for write protect           | W                 | 8 alphanumeric characters   | None          | ○                | ○ | ○ | -           |
| D58 | SOFTWR SEAL    | Software seal                                 | R                 | BREAK or KEEP   | KEEP          | ○                | ○ | ○ | -           |
| D60 | SELF CHECK     | Self-diagnostics                              | R                 | See A60   |               | ○                | ○ | ○ | -           |
| E   | AUX SET 2      | Auxiliary setting data 2                      |                   |   |               |                  |   |   |             |
| E10 | T. ZERO CMP    | Temperature compensation mode                 | W                 | OFF or ON   | OFF           | ○                | ○ | ○ | -           |
| E11 | TEMP ZERO      | Zero shift compensation                       | W                 | -99.999 to 99.999%/degC   | 0.000%/degC   | ○                | ○ | ○ | -           |
| E30 | BI DIRE MODE   | Bidirectional mode                            | W                 | OFF or ON   | OFF           | ○                | ○ | ○ | -           |
| E50 | DO SELECT      | Contact output select                         | W                 | INHIBIT, PRES, SP, TEMP, PRES/SP, PRES/TEMP, SP/TEMP, or PRES/SP/TEMP | INHIBIT       | ○                | ○ | ○ | -           |
| E51 | DO SIG. TYPE   | Signal type select                            | W                 | OFF WHEN ALARM or ON WHEN ALARM                                       | ON WHEN ALARM | ○                | ○ | ○ | -           |
| E52 | D OUTPUT       | Contact output                                | R                 | OFF or ON   | OFF           | ○                | ○ | ○ | -           |
| E60 | SELF CHECK     | Self-diagnostics                              | R                 | See A60   |               | ○                | ○ | ○ | -           |
| G   | ALARM SET      | Alarm setting                                 |                   |   |               |                  |   |   |             |
| G10 | P AL MODE      | Alert mode                                    | W                 | INHIBIT, HI. AL DETECT, LO. AL DETECT, or HI/LO. AL DETECT            | INHIBIT       | ○                | ○ | ○ | -           |
| G11 | P HI. AL VAL   | High side alert value                         | W                 | -32000 to 32000, unit specified in C20                                | 100.000 kPa   | ○                | ○ | ○ | -           |
| G12 | P LO. AL VAL   | Low side alert value                          | W                 | -32000 to 32000, unit specified in C20                                | -100.000 kPa  | ○                | ○ | ○ | -           |
| G20 | SP AL MODE     | Static pressure alert mode                    | W                 | INHIBIT, HI. AL DETECT, LO. AL DETECT, or HI/LO. AL DETECT            | INHIBIT       | ○                | - | ○ | -           |
| G21 | SP HI. AL VAL  | High side alert value of SP <sup>*2</sup>     | W                 | -32000 to 32000, unit specified in D30                                |               | ○                | - | ○ | -           |
| G22 | SP LO. AL VAL  | Low side alert value of SP                    | W                 | -32000 to 32000, unit specified in D30                                | 0.00000 MPa   | ○                | - | ○ | -           |
| G30 | T AL MODE      | Temperature alert mode                        | W                 | INHIBIT, HI. AL DETECT, LO. AL DETECT, or HI/LO. AL DETECT            | INHIBIT       | ○                | ○ | ○ | -           |
| G31 | T HI. AL VAL   | High side alert value of temperature          | W                 | -50 to 130  | 120 degC      | ○                | ○ | ○ | -           |
| G32 | T LO. AL VAL   | Low side alert value of temperature           | W                 | -50 to 130  | -40 degC      | ○                | ○ | ○ | -           |
| G50 | AUTO RECOVER   | Auto-recover from sensor error                | W                 | OFF or ON   | ON            | ○                | ○ | ○ | -           |
| G60 | SELF CHECK     | Self-diagnostics                              | R                 | See A60   |               | ○                | ○ | ○ | -           |
| H   | AUTO SET       | Automatic setup                               |                   |   |               |                  |   |   |             |
| H10 | AUTO P LRV     | Lower range value auto setup                  | W                 | -32000 to 32000, unit specified in C20                                | As specified  | ○                | ○ | ○ | -           |
| H11 | AUTO P URV     | Upper range value auto setup                  | W                 | -32000 to 32000, unit specified in C20                                | As specified  | ○                | ○ | ○ | -           |
| H20 | AUTO SP LRV    | SP lower range value auto setup               | W                 | -32000 to 32000, unit specified in D30                                | 0.00000 MPa   | ○                | - | ○ | -           |
| H21 | AUTO SP URV    | SP upper range value auto setup <sup>*2</sup> | W                 | -32000 to 32000, unit specified in D30                                |               | ○                | - | ○ | -           |
| H60 | SELF CHECK     | Self-diagnostics                              | R                 | See A60   |               | ○                | ○ | ○ | -           |
| I   | DISP SET       | Display setting                               |                   |   |               |                  |   |   |             |
| I10 | DISP OUT1      | LCD output 1                                  | W                 | PRES, PRES %, ENGR. PRES, SP, or SP %                                 | PRES %        | ○                | ○ | ○ | ○           |
| I11 | DISP OUT2      | LCD output 2                                  | W                 | PRES, PRES %, ENGR. PRES, SP, SP %, or ---                            | ---           | ○                | ○ | ○ | ○           |
| I12 | DISP OUT3      | LCD output 3                                  | W                 | See I11   | ---           | ○                | ○ | ○ | ○           |
| I13 | DISP OUT4      | LCD output 4                                  | W                 | See I11   | ---           | ○                | ○ | ○ | ○           |
| I20 | P DISP MODE    | % display mode                                | W                 | LINEAR or SQUARE ROOT   | LINEAR        | ○                | ○ | ○ | ○           |
| I21 | PRES % RESO    | % display resolution                          | W                 | NORMAL or HIGH RESOLUTION   | NORMAL        | ○                | ○ | ○ | ○           |
| I30 | ENGR. UNIT     | User set engineering unit                     | W                 | 8 alphanumeric characters   |               | ○                | ○ | ○ | ○           |
| I31 | EASY EU SET    | Engineering unit select                       | W                 |   |               | ○                | ○ | ○ | -           |
| I32 | ENGR. EXP      | Exponents                                     | W                 | ---, ×10, ×100, ×1000   | ---           | ○                | ○ | ○ | ○           |
| I33 | ENGR. LRV      | User set lower range limit                    | W                 | -32000 to 32000, unit specified in I30                                | 0.00          | ○                | ○ | ○ | ○           |
| I34 | ENGR. URV      | User set upper range limit                    | W                 | -32000 to 32000, unit specified in I30                                | 100.00        | ○                | ○ | ○ | ○           |
| I35 | ENGR. POINT    | Decimal place of user set                     | W                 | 0 to 4  | 1             | ○                | ○ | ○ | ○           |
| I40 | BAR INDICATR   | Bar indicator                                 | W                 | OFF or ON   | ON            | ○                | ○ | ○ | ○           |
| I60 | SELF CHECK     | Self-diagnostics                              | R                 | See A60   |               | ○                | ○ | ○ | -           |

\*1: R/W: R = Read only, W = Read & Write

\*2: The default value shows MWP (Maximum working pressure) of the capsule.

Since the working pressure limit varies according to the Model, refer to the General Specifications section in each user's manual.

## 5. PARAMETER SUMMARY

| No. | Parameter name | Item                                       | R/W <sup>*1</sup> | Content                                | Default value | Applicable model |   |   | Upload data |
|-----|----------------|--|-------------------|--|---------------|------------------|---|---|-------------|
|     |                |  |                   |  |               | F                | P | L |             |
| J   | ADJUST         | Adjusting data                             |                   |  |               |                  |   |   |             |
| J09 | ADJ UNIT       | Pressure adjusting unit select             | W                 | % or PRES UNIT                         | PRES UNIT     | ○                | ○ | ○ | -           |
| J10 | ADJ PRES       | Adjustment reference pressure              | R                 | Unit specified in J09                  |               | ○                | ○ | ○ | -           |
| J11 | P ZERO ADJ     | Automatic zero adjustment                  | W                 | -32000 to 32000, unit specified in J09 | 0.00000 kPa   | ○                | ○ | ○ | -           |
| J12 | P SPAN ADJ     | Automatic span adjustment                  | W                 | -32000 to 32000, unit specified in J09 | 100.000 kPa   | ○                | ○ | ○ | -           |
| J15 | P ZERO DEV     | Manual zero adjustment                     | W                 | -32000 to 32000, unit specified in J09 | 100.000 kPa   | ○                | ○ | ○ | -           |
| J16 | P SPAN DEV     | Manual span adjustment                     | W                 | -32000 to 32000, unit specified in J09 | 100.000 kPa   | ○                | ○ | ○ | -           |
| J20 | ADJ SP         | Adjustment reference pressure of SP        | R                 | Unit specified in J09                  |               | ○                | - | ○ | -           |
| J21 | SP ZERO ADJ    | Automatic SP zero adjustment               | W                 | -32000 to 32000, unit specified in J09 | 0.00000 MPa   | ○                | - | ○ | -           |
| J22 | SP SPAN ADJ    | Automatic SP span adjustment <sup>*2</sup> | W                 | -32000 to 32000, unit specified in J09 |               | ○                | - | ○ | -           |
| J25 | SP ZERO DEV    | Manual SP zero adjustment                  | W                 | -32000 to 32000, unit specified in J09 | 0.00000 MPa   | ○                | - | ○ | -           |
| J26 | SP SPAN DEV    | Manual SP span adjustment                  | W                 | -32000 to 32000, unit specified in J09 | 0.00000 MPa   | ○                | - | ○ | -           |
| J40 | OUTPUT 4mA     | 4 mA adjustment                            | W                 | -10.000 to 10.000%                     | 0.000%        | ○                | ○ | ○ | -           |
| J41 | OUTPUT 20mA    | 20 mA adjustment                           | W                 | -10.000 to 10.000%                     | 0.000%        | ○                | ○ | ○ | -           |
| J45 | AMP TEMP       | Amplifier temperature                      | R                 | Unit specified D40                     | 0 degC        | ○                | ○ | ○ | -           |
| J50 | ADJ WHO        | Adjustment information                     | W                 | 8 alphanumeric characters              |               | ○                | ○ | ○ | -           |
| J51 | ADJ DATE       | Adjustment information                     | W                 | 16 alphanumeric characters             |               | ○                | ○ | ○ | -           |
| J52 | ADJ LOC        | Adjustment information                     | W                 | 8 alphanumeric characters              |               | ○                | ○ | ○ | -           |
| J53 | ADJ DESC       | Adjustment information                     | W                 | 16 alphanumeric characters             |               | ○                | ○ | ○ | -           |
| J55 | EXT ZERO ADJ   | External zeroing permission                | W                 | INHIBIT or ENABLE                      | ENABLE        | ○                | ○ | ○ | -           |
| J56 | CLEAR ADJ      | Clear adjustment                           | W                 | ---, PRES, SP, 4-20mA, or ALL          | ---           | ○                | ○ | ○ | -           |
| J60 | SELF CHECK     | Self-diagnostics                           | R                 | See A60                                |               | ○                | ○ | ○ | -           |
| K   | TEST           | Test parameters                            |                   |  |               |                  |   |   |             |
| K10 | OUTPUT X %     | Test output % setting                      | W                 | Within a range between D20 and D21     | 0.00%         | ○                | ○ | ○ | -           |
| K40 | DO TEST        | Test contact output                        | W                 | OFF or ON                              | OFF           | ○                | ○ | ○ | -           |
| K50 | TEST KEY1      | Special maintenance parameter              | W                 |  |               | ○                | ○ | ○ | -           |
| K51 | TEST KEY2      | Special maintenance parameter              | W                 |  |               | ○                | ○ | ○ | -           |
| K52 | TEST KEY3      | Special maintenance parameter              | W                 |  |               | ○                | ○ | ○ | -           |
| K53 | TEST KEY4      | Special maintenance parameter              | W                 |  |               | ○                | ○ | ○ | -           |
| K60 | SELF CHECK     | Self-diagnostics                           | R                 | See A60                                |               | ○                | ○ | ○ | -           |
| M   | DEVICE INFO    | Device information                         |                   |  |               |                  |   |   |             |
| M10 | SERIAL NO.     | Serial number                              | R                 |  |               | ○                | ○ | ○ | -           |
| M11 | MFTR. DATE     | Manufactured date                          | R                 |  |               | ○                | ○ | ○ | -           |
| M12 | EXTRA NO.      | Customization number                       | R                 |  |               | ○                | ○ | ○ | -           |
| M15 | SOFT REV       | Software revision                          | R                 |  |               | ○                | ○ | ○ | -           |
| M16 | BRAIN REV      | BRAIN protocol revision                    | R                 |  |               | ○                | ○ | ○ | -           |
| M17 | MEMO1          | Memo                                       | W                 | 16 alphanumeric characters             |               | ○                | ○ | ○ | -           |
| M18 | MEMO2          | Memo                                       | W                 | 16 alphanumeric characters             |               | ○                | ○ | ○ | -           |
| M19 | MEMO3          | Memo                                       | W                 | 16 alphanumeric characters             |               | ○                | ○ | ○ | -           |
| M20 | ISOL MATL      | Capsule material                           | W                 |  |               | ○                | ○ | ○ | -           |
| M21 | FILL FLUID     | Fill fluid                                 | W                 |  |               | ○                | ○ | ○ | -           |
| M22 | GASKET MATL    | Gasket material                            | W                 |  |               | ○                | ○ | ○ | -           |
| M23 | PRO CON MATL   | Flange material                            | W                 |  |               | ○                | ○ | ○ | -           |
| M24 | D-VENT MATL    | Vent plug material                         | W                 |  |               | ○                | ○ | ○ | -           |
| M25 | PRO CON TYPE   | Process connection type                    | W                 |  |               | ○                | ○ | ○ | -           |
| M26 | RS ISOL MATL   | Remote seal material                       | W                 |  |               | ○                | ○ | ○ | -           |
| M27 | PRO CON SIZE   | Flange size                                | W                 |  |               | ○                | ○ | ○ | -           |
| M28 | NUM RS         | Number of remote seal                      | W                 |  |               | ○                | ○ | ○ | -           |
| M29 | RS FILL FLUID  | Fill fluid of remote seal                  | W                 |  |               | ○                | ○ | ○ | -           |
| M30 | RS TYPE        | Remote seal type                           | W                 |  |               | ○                | ○ | ○ | -           |
| M50 | MS CODE 1      | Model and suffix code 1                    | W                 |  |               | ○                | ○ | ○ | -           |
| M51 | MS CODE 2      | Model and suffix code 2                    | W                 |  |               | ○                | ○ | ○ | -           |
| M52 | MS CODE 3      | Model and suffix code 3                    | W                 |  |               | ○                | ○ | ○ | -           |
| M53 | MS CODE 4      | Model and suffix code 4                    | W                 |  |               | ○                | ○ | ○ | -           |
| M54 | MS CODE 5      | Model and suffix code 5                    | W                 |  |               | ○                | ○ | ○ | -           |
| M55 | MS CODE 6      | Model and suffix code 6                    | W                 |  |               | ○                | ○ | ○ | -           |
| M60 | SELF CHECK     | Self-diagnostics                           | R                 | See A60                                |               | ○                | ○ | ○ | -           |

\*1: R/W: R = Read only, W = Read & Write

\*2: The default value shows MWP (Maximum working pressure) of the capsule.

Since the working pressure limit varies according to the Model, refer to the General Specifications section in each user's manual.

## 5. PARAMETER SUMMARY

| No. | Parameter name | Item                            | R/W <sup>*1</sup> | Content           | Default value | Applicable model |   |   | Upload data |
|-----|----------------|---------------------------------|-------------------|-------------------|---------------|------------------|---|---|-------------|
|     |                |                                 |                   |                   |               | F                | P | L |             |
| P   | Record         | History of errors               |                   |                   |               |                  |   |   |             |
| P10 | ERROR REC 1    | Last error                      | W                 | See A60           | GOOD          | ○                | ○ | ○ | -           |
| P12 | ERROR REC 2    | Second recent error             | W                 | See A60           | GOOD          | ○                | ○ | ○ | -           |
| P14 | ERROR REC 3    | Third recent error              | W                 | See A60           | GOOD          | ○                | ○ | ○ | -           |
| P16 | ERROR REC 4    | Forth recent error              | W                 | See A60           | GOOD          | ○                | ○ | ○ | -           |
| P60 | SELF CHECK     | Self-diagnostics                | R                 | See A60           |               | ○                | ○ | ○ | -           |
| T   | CHARACTERIZR   | Signal characterizer setting    |                   |                   |               |                  |   |   |             |
| T10 | S. C. ENABLE   | Signal characterizer permission | W                 | INHIBIT or ENABLE | INHIBIT       | ○                | ○ | ○ | -           |
| T11 | NUM OF POINT   | Number of coordinates           | W                 | 0 to 9            | 0             | ○                | ○ | ○ | -           |
| T20 | X START (FIX)  | Start point of X                | R                 | 0.00%             |               | ○                | ○ | ○ | -           |
| T21 | Y START (FIX)  | Start point of Y                | R                 | 0.00%             |               | ○                | ○ | ○ | -           |
| T22 | X1             | Coordinate 1 of X               | W                 | 0.00 to 100.00%   | 10.00         | ○                | ○ | ○ | -           |
| T23 | Y1             | Coordinate 1 of Y               | W                 | 0.00 to 100.00%   | 10.00         | ○                | ○ | ○ | -           |
| T24 | X2             | Coordinate 2 of X               | W                 | 0.00 to 100.00%   | 20.00         | ○                | ○ | ○ | -           |
| T25 | Y2             | Coordinate 2 of Y               | W                 | 0.00 to 100.00%   | 20.00         | ○                | ○ | ○ | -           |
| T26 | X3             | Coordinate 3 of X               | W                 | 0.00 to 100.00%   | 30.00         | ○                | ○ | ○ | -           |
| T27 | Y3             | Coordinate 3 of Y               | W                 | 0.00 to 100.00%   | 30.00         | ○                | ○ | ○ | -           |
| T28 | X4             | Coordinate 4 of X               | W                 | 0.00 to 100.00%   | 40.00         | ○                | ○ | ○ | -           |
| T29 | Y4             | Coordinate 4 of Y               | W                 | 0.00 to 100.00%   | 40.00         | ○                | ○ | ○ | -           |
| T30 | X5             | Coordinate 5 of X               | W                 | 0.00 to 100.00%   | 50.00         | ○                | ○ | ○ | -           |
| T31 | Y5             | Coordinate 5 of Y               | W                 | 0.00 to 100.00%   | 50.00         | ○                | ○ | ○ | -           |
| T32 | X6             | Coordinate 6 of X               | W                 | 0.00 to 100.00%   | 60.00         | ○                | ○ | ○ | -           |
| T33 | Y6             | Coordinate 6 of Y               | W                 | 0.00 to 100.00%   | 60.00         | ○                | ○ | ○ | -           |
| T34 | X7             | Coordinate 7 of X               | W                 | 0.00 to 100.00%   | 70.00         | ○                | ○ | ○ | -           |
| T35 | Y7             | Coordinate 7 of Y               | W                 | 0.00 to 100.00%   | 70.00         | ○                | ○ | ○ | -           |
| T36 | X8             | Coordinate 8 of X               | W                 | 0.00 to 100.00%   | 80.00         | ○                | ○ | ○ | -           |
| T37 | Y8             | Coordinate 8 of Y               | W                 | 0.00 to 100.00%   | 80.00         | ○                | ○ | ○ | -           |
| T38 | X9             | Coordinate 9 of X               | W                 | 0.00 to 100.00%   | 90.00         | ○                | ○ | ○ | -           |
| T39 | Y9             | Coordinate 9 of Y               | W                 | 0.00 to 100.00%   | 90.00         | ○                | ○ | ○ | -           |
| T40 | X END (FIX)    | End point of X                  | R                 | 100.00%           |               | ○                | ○ | ○ | -           |
| T41 | Y END (FIX)    | End point of Y                  | R                 | 100.00%           |               | ○                | ○ | ○ | -           |
| T60 | SELF CHECK     | Self-diagnostics                | R                 | See A60           |               | ○                | ○ | ○ | -           |

\*1: R/W: R = Read only, W = Read & Write

# APPENDIX 1. SAFETY INSTRUMENTED SYSTEMS INSTALLATION



## WARNING

The contents of this appendix are cited from exida.com safety manual on the EJX series pressure transmitters specifically observed for the safety transmitter purpose. When using the EJX for Safety Instrumented Systems (SIS) application, the instructions and procedures in this section must be strictly followed in order to preserve the transmitter for that safety level.

## A1.1 Scope and Purpose

This section provides an overview of the user responsibilities for installation and operation of the EJX in order to maintain the designed safety level for Safety Instrumented Systems (SIS) applications. Items that will be addressed are proof testing, repair and replacement of the transmitter, reliability data, lifetime, environmental and application limits, and parameter settings.

## A1.2 Using the EJX for an SIS Application

### A1.2.1 Safety Accuracy

The EJX has a specified safety accuracy of 2%. This means that the internal component failures are listed in the device failure rate if they will cause an error of 2% or greater.

### A1.2.2 Diagnostic Response Time

The EJX will report an internal failure within 5 seconds of the fault occurrence.

### A1.2.3 Setup

During installation the transmitter must be setup with engineering units parameters. This is typically done with a handheld terminal. These parameters must be verified during the installation to insure that the correct parameters are in the transmitter. Engineering range parameters can be verified by reading these parameters from the optional local display or by checking actual calibration of the transmitter.

The calibration of the transmitter must be performed after parameters are set.

### A1.2.4 Required Parameter Settings

The following parameters need to be set in order to maintain the designed safety integrity.

Table A1.2.4 Required Parameter Settings

| Item                     | Description  |
|--------------------------|--|
| Burnout direction switch | To specify if the output should go 21.6 mA or higher or 3.6 mA or lower upon detection of an internal failure. |
| Write protection switch  | The write function should be disabled.   |

TA0101.EPS

### A1.2.5 Proof Testing

The objective of proof testing is to detect failures within the transmitter that are not detected by the diagnostics of the transmitter. Of main concern are undetected failures that prevent the safety instrumented function from performing its intended function. See table A1.2.5 for proof testing method.

The frequency of the proof tests (or the proof test interval) is to be determined in the reliability calculations for the safety instrumented functions for which the EJX is applied. The actual proof tests must be performed more frequently or as frequently as specified in the calculation in order to maintain required safety integrity of the safety instrumented function.

The following tests need to be specifically executed when a proof test is performed. The results of the proof test need to be documented and this documentation should be part of a plant safety management system. Failures that are detected should be reported to Yokogawa.

The personnel performing the proof test of the transmitter should be trained in SIS operations including bypass procedures, EJX transmitter maintenance, and company management of change procedures.

Table A1.2.5 Proof Testing

| Testing method   | Tools required  | Expected outcome         | Remarks  |
|--|---|--------------------------|--|
| <b>Functional test:</b><br>1. Follow all Management of Change procedures to bypass logic solvers if necessary.<br>2. Execute HART/BRAIN command to send value to high alarm (21.5 mA) and verify that current has reached this level.<br>3. Execute HART/BRAIN command to send value to low alarm (3.6 mA) and verify that current has reached this level.<br>4. Restore logic solvers operation and verify. | <ul style="list-style-type: none"> <li>• Handheld terminal</li> </ul>                                       | Proof Test Coverage =52% | The output needs to be monitored to assure that the transmitter communicates the correct signal. |
| Perform three point calibration along with the functional test listed above.   | <ul style="list-style-type: none"> <li>• Handheld terminal</li> <li>• Calibrated pressure source</li> </ul> | Proof Test Coverage =99% |  |

TA0102.EPS

### A1.2.6 Repair and Replacement

If repair is to be performed with the process online the EJX will need to be bypassed during the repair. The user should setup appropriate bypass procedures.

In the unlikely event that the EJX has a failure, the failures that are detected should be reported to Yokogawa.

When replacing the EJX, the procedure in the installation manual should be followed.

The personnel performing the repair or replacement of the EJX should have a sufficient skill level.

### A1.2.7 Startup Time

The EJX generates a valid signal within 1 second of power-on startup.

### A1.2.8 Firmware Update

In case firmware updates are required, they will be performed at factory. The replacement responsibilities are then in place. The user will not be required to perform any firmware updates.

### A1.2.9 Reliability Data

A detailed Failure Mode, Effects, and Diagnostics Analysis (FMEDA) report is available from Yokogawa with all failure rates and failure modes.

The EJX is certified up to SIL2 for use in a simplex (1oo1) configuration, depending on the PFDavg calculation of the entire Safety Instrumented Function.

The development process of the EJX is certified up to SIL3, allowing redundant use of the transmitter up to this Safety Integrity Level, depending the PFDavg calculation of the entire Safety Instrumented Function.

When using the transmitter in a redundant configuration, the use of a common cause factor ( $\beta$ -factor) of 2% is suggested. (However, if the redundant transmitters share an impulse line or if clogging of the separate impulse lines is likely, a common cause factor of 10% is suggested.)

Note that the failure rates of the impulse lines need to be accounted for in the PFDavg calculation.

### A1.2.10 Lifetime Limits

The expected lifetime of the EJX is 50 years. The reliability data listed the FMEDA report is only valid for this period. The failure rates of the EJX may increase sometime after this period. Reliability calculations based on the data listed in the FMEDA report for EJX lifetimes beyond 50 years may yield results that are too optimistic, i.e. the calculated Safety Integrity Level will not be achieved.

**A1.2.11 Environmental Limits**

The environmental limits of the EJX are specified in the user’s manual IM 01C25.

**A1.2.12 Application Limits**

The application limits of the EJX are specified in the user’s manual IM 01C25. If the transmitter is used outside of the application limits, the reliability data listed in A1.2.9 becomes invalid.

**A1.3 Definitions and Abbreviations**

**A1.3.1 Definitions**

|                   |   |
|-------------------|---|
| Safety            | Freedom from unacceptable risk of harm  |
| Functional Safety | The ability of a system to carry out the actions necessary to achieve or to maintain a defined safe state for the equipment/ machinery/plant/apparatus under control of the system  |
| Basic Safety      | The equipment must be designed and manufactured such that it protects against risk of damage to persons by electrical shock and other hazards and against resulting fire and explosion. The protection must be effective under all conditions of the nominal operation and under single fault condition |
| Verification      | The demonstration for each phase of the life-cycle that the (output) deliverables of the phase meet the objectives and requirements specified by the inputs to the phase. The verification is usually executed by analysis and/or testing   |
| Validation        | The demonstration that the safety-related system(s) or the combination of safety-related system(s) and external risk reduction facilities meet, in all respects, the Safety Requirements Specification. The validation is usually executed by testing   |

Safety Assessment The investigation to arrive at a judgment -based on evidence- of the safety achieved by safety-related systems

Further definitions of terms used for safety techniques and measures and the description of safety related systems are given in IEC 61508-4.

**A1.3.2 Abbreviations**

|       |   |
|-------|---|
| FMEDA | Failure Mode, Effects and Diagnostic Analysis |
| SIF   | Safety Instrumented Function                  |
| SIL   | Safety Integrity Level                        |
| SIS   | Safety Instrumented System                    |
| SLC   | Safety Lifecycle                              |

# REVISION RECORD

Title: EJX Series BRAIN Communication Type  
Manual No.: IM 01C25T03-01E

| Edition | Date      | Page                | Revised Item  |
|---------|-----------|---------------------|---|
| 1st     | Apr. 2004 | -                   | New publication   |
| 2st     | Oct. 2004 | 3-19                | 3.2.3 (20) Add capillary fill fluid density compensation setting procedure.   |
| 3rd     | Aug. 2009 | 3-8<br>3-14<br>3-18 | 3.2.3 (5) Add example for hysteresis.<br>3.2.3 (15) Correct misprint.<br>3.2.3 (19) Add CAUTION. Add note for hysteresis. |
|         |           |                     |   |