

General Specifications

NT610□J, NT620□J, NT625AJ
VDS



GS 34P02A02-01E

■ GENERAL

VDS is a software package that runs under a Windows operating system and implements a Web-based human machine interface, OPC server functions, data acquisition from a variety of controllers and devices, and historical data management. Other features include:

- An ordinary Web browser is required as the platform to run operation and monitor windows implemented as Java applets, offering platform- and scale-independent HMI clients.
- All window data are created on and stored in a single HMI server and HMI clients do not contain window files, namely, they are thin clients. Changes to window files only require work at the server; there is no need for modifications at each client.
- Integrated monitoring of data of multiple data servers is possible from an HMI client
- Integrated information of multiple VDSs can be viewed at a personal computer using HMI client functions.
- Allows operation and monitoring via the Internet, an intranet, and/or a private LAN; even if located beyond a firewall.
- Security functions allow restriction of access according to operator privilege level, and automatic generation of operation logs, thus assuring system and data security. This enables you to build systems which comply with "FDA (U. S. Food and Drug Administration), 21 CFR Part 11 – rules concerning electronic record-keeping and electronic signatures that are acceptable as equivalent to paper records.

■ SYSTEM SPECIFICATIONS

VDS consists of following functions:

● Data server functions

A data server acquires data from controllers and I/O devices such as autonomous controllers FCN/FCJ and programmable logic controllers, saves them, and passes them to HMI servers and Visual Basic applications. A data server manages sets of data as control objects (tags).

● HMI server functions

An HMI server delivers, to HMI clients, operation and monitoring window data for data residing in data servers. An HMI server can access any data servers running on the same computer or a different computer on the network.

● HMI client functions

An HMI client accesses an HMI server via a generic Web browser to display operation and monitoring windows. An HMI client can exist on the same computer as an HMI server or a different computer on the network.

Item	Specification	Remarks
VDSs	Up to 4 per control LAN	Consult Yokogawa if more VDSs needed.
VDS interconnections (data server-to-HMI server connections)	Up to 4 data servers per HMI server	Maximum number of data servers an HMI server can access, including the HMI server on the same computer
HMI clients	Up to 50 per HMI server	Maximum number of HMI clients that can access an HMI server, including the HMI client on the same computer
I/O devices and controllers	Up to 32 per database server	
Control objects (tags)	Up to 5000	

T01E.EPS

■ SYSTEM CONFIGURATIONS (Sample)

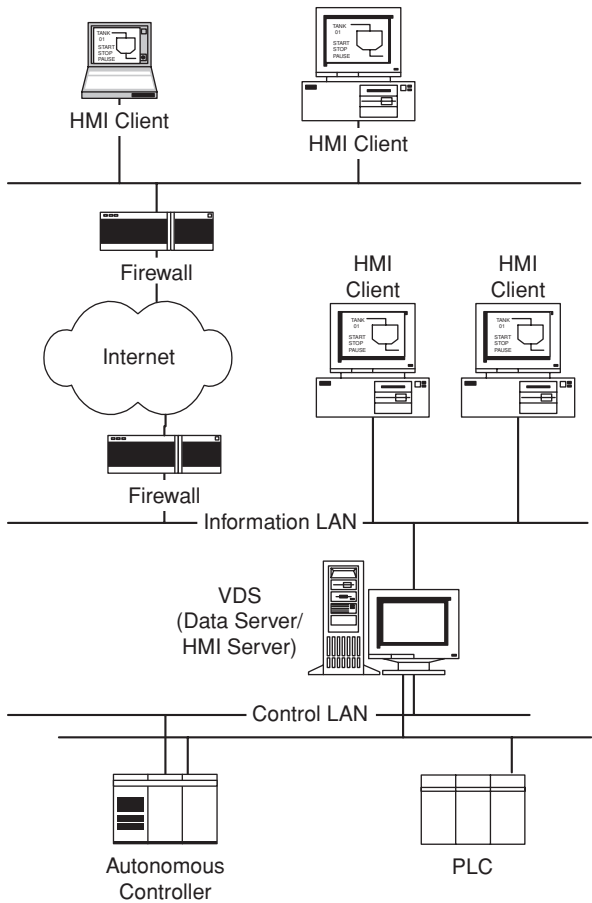

F01E.EPS

Large Scale

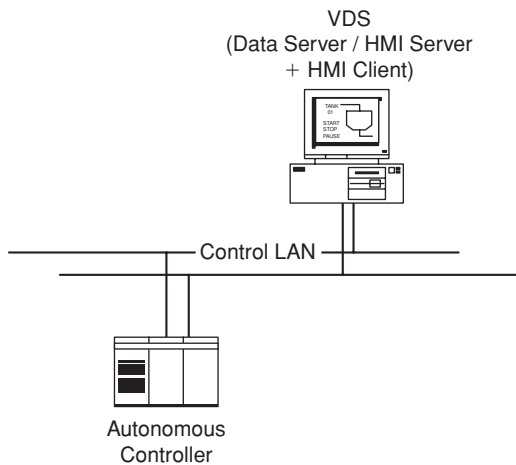

F02E.EPS

Small Scale

■ SYSTEM REQUIREMENTS

Data Server/HMI Server

Items	Specifications
Personal Computer	IBM PC/AT compatible
CPU	Pentium III 700 MHz, Celeron 1GHz or better
RAM	Windows 2000 : At least 256 MB (512 MB or more recommended)
	Windows XP : At least 512 MB (1 GB or more recommended)
Hard Disk	At least 1 GB of free space is required. (The overall size of the hard disk of the computer should be 5 GB or more.)
Ethernet adapter	An Ethernet adapter that is supported by the operating system specified below is required at installation.
CD-ROM Drive	A CD-ROM drive that is supported by the operating system specified below is required.
Peripheral devices	An MO, digital audio tape, CD-RW, or other removable storage drive supported by the operating system specified below is required for backup.
USB or parallel (Centronics) port	Required to install an ID module.
Printer	A laser printer or color printer for A4-size paper (that is supported by the operating system specified below) is required. An ESC/P code-enabled serial printer is required for alarm printing.
OS	Windows 2000 Professional SP4 Windows XP Professional SP1, SP2
Web browser	Internet Explorer 6.0 (SP1, SP2) plus Java Plug-in 1.4.2_09

T02E.EPS

HMI Client

Items	Specifications
Personal Computer	IBM PC/AT compatible
CPU	Pentium III or Celeron 600 MHz or better
RAM	Windows 2000 : At least 256 MB (512 MB or more recommended)
	Windows XP : At least 256 MB (512 MB or more recommended)
Hard disk	At least 10 MB of free space is required. (The overall size of the hard disk of the computer should be 1 GB or more.)
Ethernet adapter	An Ethernet adapter that is supported by the operating system specified below is required at installation.
CD-ROM drive	A CD-ROM drive that is supported by the operating system specified below is required.
Peripherals	Sound card and speaker are required for audible messages
OS	Windows 2000 Professional SP4 Windows XP Home Edition SP1, SP2 Windows XP Professional SP1, SP2
Web browser	Internet Explorer 6.0 (SP1, SP2) plus Java Plug-in 1.4.2_09

T03E.EPS

If the same computer runs the HMI server and an HMI client, the system requirements for a data server/HMI server apply.

HMI CLIENT FUNCTION FUNCTIONS

An HMI client receives window data from the HMI server and displays them on a Web browser. The following table outlines the functions of an HMI client.

Item	Description
Object View	Displays data of individual objects in data servers such as faceplates or tuning panels.
Graphic Window Display	Presents graphical windows in addition to Object View.
Access control	Can limit operational privileges depending on the user through user authentication interlinking with the security of data servers.
Audible message output	The message primitive (a graphic part for displaying messages), if pasted on a graphic window on the screen, will output alarm sound when an alarm occurs. Arbitrary WAV format files can be selected for the sounds.

T04E.EPS

General Specifications

- Colors: True colors
- The window size can be set arbitrarily for each window.
- The data refresh interval is one second or longer (for only foreground data).

Primitives

Basic primitives	Pen
	Straight line
	Ploy Line _ Polyline
	Arc
	Fill area
	Circle
	Ellipse
	Sector
Control primitives	Marker
	Text
	Process data character string
	Process data rectangle bar
	Process data arrow bar
	Process data cylindrical bar
	Line graph
	User-defined line graph
	Bar graph
	Step graph
	Radar chart
	X-Y graph
	Touch target
Bitmap primitive	Button
	Message
Link parts (*)	Trend
	Bitmap
	Faceplates
	ISA symbols
	Motors
	Pipes
	Pumps
	Switches
Tanks	
Application primitives	Valves
	Power demand graph
	Tuning trend

T05E.EPS

* Each primitive represents a group of primitives.

Modification Specifications

Pattern modifications

- Modification actions: Color modification, disappearance, blinking, character modification, highlighting
- Modification type: Executes every time the specified condition is true or only when the window is opened and the condition is true at that time.
- Modification conditions: Up to eight conditions can be set per primitive.

Coordinates modifications

- Dynamic modification according to the value of the specified data item.

Touch targets and pushbuttons

- Provide access to a URL, monitoring window, logon dialog box, dialog box for data entry, menu window, data setting, and printing.

● **Trend Primitive**

Trend primitive displays history data, which is saved in history server of data server, in graph image.

● **Message Primitive**

Message primitive displays alarm, message, and message history, which are saved in message management of data server. Alarm summary displays and operates currently occurring alarms. Historical displays and operates historical message (past message).

Function	Description
Message Display	Displaying message of alarm summary or historical
Filtering	Filtering messages
Acknowledge	Acknowledging messages
Audible Message	Outputting audible message for each severity
Printing	Printing message in report format Supporting red and black printing with color printer

T06E.EPS

● **Power Demand Graph Primitive**

Power demand graph primitive displays power demand in graph image.

● **Tuning Trend Primitive**

Tuning trend primitive displays data in graph image with the same method as tuning panel.

HMI SERVER FUNCTION

HMI server collects data from data server and delivers Web based screen to HMI client. HMI server consists of HMI server and graphic designer.

● **HMI Server**

HMI server delivers the data collected by data server or the graphic window data to HMI client in Web browser format.

Function	Description
Web Server	Receiving requests from Web browser
Session Management	Maintaining/managing session for each log-on from HMI client
Data Access	Accessing into data server

T07E.EPS

● **Graphic Designer**

Graphic designer creates and modifies the graphic page.

DATA SERVER FUNCTIONS

A data server and I/O object comprise the data server functions and they are configured using Object Builder.

● **Data Server**

Using the I/O object, the data server exchanges data with I/O devices and controllers, and performs various processes for field data. The acquired field data and processing results can be accessed from outside the data server, for example, from HMI servers and Visual Basic applications.

● **Control Objects**

A control object controls a set of data such as inputs and outputs and corresponds to what is generally called a tag. The number of data that can be handled by a control object varies with the object type. Up to 5000 control objects (*1) can be defined in the data server. The user can group two or more control objects comprising a particular unit of functions into one and make a copy of each group. Programs outside the data server can easily access data in individual control objects via OPC Data Access 2.0 interfaces or OLE Automation interfaces.

*1: An object that can control data exceeding 128 bytes in size is not counted as one object but is counted as the number incremented by 1 for each 128 bytes when assessing the capacity. For example, a single object handling 32,768 bytes is counted as 256 objects because 32,768 divided by 128 is 256. The objects contained in each group of objects are also counted individually when it comes to capacity.

The following kinds of control objects are prepared.

Device tag objects

A device tag reads and writes data from/to controllers and I/O devices using an I/O driver, and carries out I/O processing including various data conversions and alarm detection.

Application support objects

An application support object features functions for supporting actions by an application, such as generating a time trigger.

Control objects provided by standard application portfolio

A control object provided by a standard application portfolio and designed for communication with a PAS POU (short for process automation system's program organization unit) running in an autonomous controller. A control object of this type features functions to input/output data from/to a PAS POU, perform input data conversion, and transfer alarms occurring in the PAS POU.

Control objects provided by optional application portfolio

Control objects provided by an optional application portfolio include objects designed to communicate with a temperature controller and power monitor, such as data input/output.

● **Visual Basic Applications Edition (VBA)**

The data server implements VBA, allowing functions provided with each control object to be enhanced and multiple control objects to interlink with each other. (The number of control objects VBA programs on the data server can handle is limited to 2000; nevertheless, VB application programs can access up to a total of 5000 control objects.)

● **I/O Object**

The I/O object is a component for linking various controllers and I/O devices. In response to input/output requests from each control object on the data server, the I/O object performs communication with the specified controller or I/O device. An I/O driver is prepared for each controller or I/O device model, and plugging a proper driver into the I/O object establishes a connection to the intended controller or device. A total of up to 32 drivers can be plugged into the I/O object.

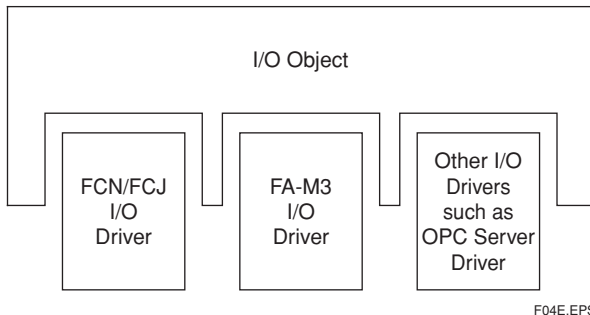

An I/O driver encapsulates the interface specific to each I/O device or controller model and enables the data server and application programs to access an I/O device or controller via a common interface. An I/O driver can:

- Input and output data from/to the specified I/O device or controller.
- Receive asynchronous events from the specified controller.
- Manipulate and control functions specific to the specified controller.

The following I/O drivers are included as standard:

Models Supported	Interface	Functions
FCN/FCJ autonomous controllers	Ethernet TCP/IP	Reads and writes control data, and receives alarms.
FA-M3 controllers	Ethernet (UDP/IP) or RS-232-C (*1)	Reads and writes sequence element values/statuses, receives asynchronous data, and sets the date and time.

*1: If you use RS-232-C/RS-485 converter for I/O device which has RS-485 interface, RS-232-C/RS-485 converter which has the echo back function is unusable as an adapter.

● **Object Builder**

Object Builder presents an integrated environment in which the user can make settings for the data server and perform debugging, and provides intuitive interfaces for the user to:

- Define the I/O object.
- Define control objects.
- Define alarms.
- Import configuration data for autonomous controllers of STARDOM defined using Logic Designer.
- Develop and debug VBA programs.
- Run Security Builder, History Builder, and Report Builder.
- Make settings for simulation functions (available as the optional Test Function Package).

■ **SYSTEM SUPPORT FUNCTIONS**

● **Message Management**

Message management performs integrated management of error and alarm messages occurring in the VDS system programs, connected controllers and devices (including FCN/FCJ autonomous controllers and FA-M3 controllers), and Visual Basic application programs as well as user operation records and process event messages. The table below summarizes messages that can be handled by message management.

Message Type		Description
System messages		Messages generated by a VDS system program
Application messages	User messages	Messages of general information generated by an application program, such as user operation records and event data. User messages do not require the user for acknowledgement.
	User alarms	Messages of an alarm generated by an application program. User alarms require the user for acknowledgement.
Control object messages	Process messages	Messages notifying an operation record of a user action to a control object
	Process alarms	Messages of an alarm pertaining to a control object. Process alarms require the user for acknowledgement.
	System alarms	Messages notifying an alarm occurring in an autonomous controller, such as a change in status. System alarms require the user for acknowledgement.

T09E.EPS

Message management stores these messages to a rotary file referred to as the message log file, which can contain up to 5000 messages. One or more of the following actions take place for individual messages:

- Display in the alarm summary (a message primitive)
- Logging to the message log file (and displaying of the contents in Message Viewer and Message History).
- Logging to a text file
- Display in a dialog box
- Voice output
- Printing using a serial printer
- Notification to a VB application program
- Logging to an Oracle database

● **Process Management**

Process management performs integrated management of the VDS system programs and Visual Basic application programs, allowing automatic start and shutdown of the system. In particular, process management can:

Mode	Description
Operation Mode	Starting up system program and registered VB application automatically. Performing usual operation and debug.
Development Mode	Starting up only basic system program such as message management program. Development mode that includes building of data server (etc.).
Shutdown Mode	Status the system program or VB application is stopped. Mode for back up work.

T10E.EPS

- Manage and control VDS's operation mode.
- Start and shut down the VDS system.
- Start the desired VB application program.
- Issue an advance notice for a shutdown of data server to a VB application program.

● **ISAM (Indexed Sequential Access Method) File**

The ISAM is a scheme for decreasing the time necessary to locate a data record within a large database, given a key value (index) that identifies the record. An ISAM file allows easy access from a VB application by using a key and is ideal for quick search of production data. Microsoft ADO (ActiveX Data Objects) is the interface for access.

Item	Description
Max. number of opened file	255 per system
Max. number of files can be handled	32 per process
Max. length of record	4096 bytes
Max. number of record	500000 records
Field type	16-Bit Signed Integer Data (Array is definable)
	32-Bit Signed Integer Data (Array is definable)
	Single-precision Actual Number (Array is definable)
	Double-precision Actual Number (Array is definable)
	Text (character string)
Record type	Fixed length
File type	Standard/Hybrid/Memory

T11E.EPS

● **Security**

The users can be divided into groups and the ranges of permissible operations can be set differently for each group. The log of actions performed by each user during runtime can be saved for recording. These prevent problems such as operation mistakes and ensure system security.

● **Operational restriction settings for each user group**

The ranges of permissible operations can be predefined for each user group:

- Access to control objects via the HMI server, VB application or tuning windows for FCN/FCJ controllers
- Alterations to archived long-term data files of historical data acquired
- Running of system programs (builders, tools, etc.)
- Access to tuning windows
- Switching of VDS's operation mode
- Changes to security log definitions
- Alarm acknowledgment
- Deleting messages in the message history file, changing the number of stored messages
- Stopping the sound of the HMI server from the HMI client

● **Security logs**

For each item that is operated, the log of actions performed by each user during runtime can be saved for recording (what property was manipulated via which faceplate by who will be recorded).

● **VB Property Link**

Data link with other Visual Basic applications is made easy with this function.

Note: VB Property Link is available in Visual Basic Version 6. Not available in Version 7 (VB.Net). "OPC Data Link Package for .NET" (refer to GS 34P02H51-01E if you need) is available in .NET framework including VB .NET.

■ **SOFTWARE OFFERINGS**

VDS is offered as basic software and optional software packages.

● **VDS Basic Software**

VDS basic software requires a basic software license for each computer to run. A basic software license includes the license for the first HMI client to access the HMI server. (The HMI client within the same computer also needs a license to access the HMI server.) To increase the HMI clients, an additional HMI client license(s) need to be purchased.

● **Basic software licenses**

Choose a suitable basic software license depending on the required capacity of the data server (i.e., the number of implementable control objects). In addition, the license for each scale is further available in two versions: full-time version and runtime version.

● **Full-time version**

The full-time version offers both development and runtime environments, allowing a system to be built, applications to be developed and debugged, and the developed applications to be run.

Run-time version

The runtime version offers only the runtime environment. Use the full-time version to build a system and develop and debug applications.

Upgrade kits

For such needs as increasing control objects for a system expansion, upgrade kits are available.

HMI client additional licenses

A basic software license allows only one session with the HMI server at one time where a session is a period of time from when an HMI client logs on to the server to when it logs off. HMI client additional licenses are offered for a system having two or more HMI clients or for increasing the HMI clients at a system expansion. Note that each HMI client usually establishes only one session when accessing the server; however, when opening two or more Web browser windows and logging on to the HMI server twice, two sessions will be established.

● **Optional Software**

Optional software is offered for adding functions. A software license is required for each computer that runs the corresponding optional software. For a package offered in two versions, the full-time version can run under only the full-time version of VDS basic software and the runtime version can run under only the runtime version of VDS basic software. A package not offered in these two versions can run under either version of VDS basic software.

Name		Model	Related Document
Report Package	For full-time	NT301AJ	GS 34P02H01-01E
	For run-time	NT301RJ	
Trend Package	For full-time	NT302AJ	GS 34P02H02-01E
	For run-time	NT302RJ	
MELSEC Driver		NT351AJ	GS 34P02G01-01E
SYSMAC Driver		NT356AJ	GS 34P02G06-01E
OPC Server Driver		NT358AJ	GS 34P02G08-01E
DARWIN Driver		NT365AJ	GS 34P02H05-01E
Power Monitor Driver		NT366AJ	GS 34P02H06-01E
Custom Driver Interface		NT341AJ	GS 34P02H41-01E
Test Package	For full-time	NT303AJ	GS 34P02M01-01E
	For run-time	NT303RJ	
Multi-task Package	For full-time	NT304AJ	GS 34P02H04-01E
	For run-time	NT304RJ	
Extended Security Package		NT320AJ	GS 34P02H07-01E
Operation Shield Package		NT321AJ	GS 34P02H08-01E
OPC Data Link Package for .NET		NT336AJ	GS 34P02H51-01E

T12E.EPS

■ STYLES OF SOFTWARE SUPPLY

Software Medium

Programs and user's manuals for VDS basic software and optional software are supplied as a CD-ROM, and hence a CD-ROM drive is needed to install them in a PC. To run a program you need a license ID and ID module.

Order ID Sheet

An order ID sheet with the order ID and password entries comes with each VDS basic software license or license for optional software. Access the specified Web site of Yokogawa and enter the order ID and password. Then, the respective license IDs for the supplied software titles will be given. To use the software, the given license IDs need to be registered with the ID module.

ID Module

An ID module (hardware) that comes with each VDS basic software license needs to be installed to a USB port or Centronics printer port of the PC to run a data server and/or HMI server using the VDS basic software. An ID module need not be installed in a PC running an HMI client solely.

■ NOTICE FOR THIRD-PARTY PRODUCTS

VDS is software that makes the most of commercial-off-the-shelf (COTS) software, so third-party products meeting the specifications required by VDS are myriad. Yokogawa, however, does not guarantee correct operations of all such products. The pieces of software described in the General Specifications and User's Manuals of VDS, such as the Windows operating system and Microsoft Excel, will operate correctly to the extent of the specifications. Correct operation of the system cannot be guaranteed if any other third-party software is installed and used with a VDS product.

Yokogawa has conducted combination tests on third-party products that many want to use with VDS. These tests will also be performed on new third-party products as required. Nevertheless, these tests simply check the basic operations in combination with VDS and do not mean to assure correct operations. The up-to-date results of these tests will be available to those who have concluded a support contract.

MODELS AND SUFFIX CODES

● Software Medium

		Description
Model	NT201AJ	VDS software media
Suffix Codes	-P	Programs (including electronic documents)
	C	CD-ROM
	1	Always 1
	1	Always 1
	E	English version

T13E.EPS

● Basic Software License

		Description
Model	NT610FJ	VDS basic software license for full-time
	NT610RJ	VDS basic software license for run-time
Suffix Codes	-L	License
	U	ID module for USB
	P	ID module for printer port
	00	50 objects
	01	100 objects
	02	200 objects
	05	500 objects
	10	1000 objects
	15	1500 objects
	20	2000 objects
	50	5000 objects
	E	English version

T14E.EPS

● Upgrade Kit

		Description
Model	NT620FJ	VDS Upgrade kit for full-time
	NT620RJ	VDS Upgrade kit for run-time
Suffix Codes	-L	License
	W	Issued at Web
	01	50 to 100 objects
	02	100 to 200 objects
	05	200 to 500 objects
	10	500 to 1000 objects
	15	1000 to 1500 objects
	20	1500 to 2000 objects
	50	2000 to 5000 objects
	A	Standard

T15E.EPS

● HMI Client Additional Licenses

		Description
Model	NT625AJ	HMI Client additional licenses
Suffix Codes	-L	License
	W	Issued at Web
	01	Add 1 Client
	05	Add 5 Clients
	A	Standard

T16E.EPS

● Spare Parts

		Description
Model	NT221AA	ID module for USB
	NT222AA	ID module for printer port

T17E.EPS

ORDERING INSTRUCTION

Specify model and suffix code.

TRADEMARKS

- STARDOM is a trademark of Yokogawa Electric Corporation.
- Microsoft, Windows, and Visual Basic are either registered trademarks or trademarks of Microsoft Corporation in the United States and/or other countries.
- Ethernet is a registered trademark of Xerox Corporation.
- Java is a trademark or registered trademark of SUN Microsystems, Inc. in the US and other countries.
- IBM is a registered trademark of IBM Corporation.
- MELSEC is a registered trademark of Mitsubishi Electric Corporation.
- SYSMAC is a registered trademark of Omron Corporation.
- Pentium is a registered trademark of Intel Corporation.
- Oracle is a registered trademark of Oracle Corporation.
- Other product and company names appearing in this document are trademarks or registered trademarks of their respective holders.