

■ GENERAL

This GS covers the connections between field devices and input/output modules for an FCN autonomous controller.

■ SIGNAL CONNECTIONS

● Variation of Signal Connections

An I/O module can be connected to field devices via terminals or a customer-supplied MIL connector cable. The following explains the terminal blocks that can be installed on an I/O module and the signal wiring for them.

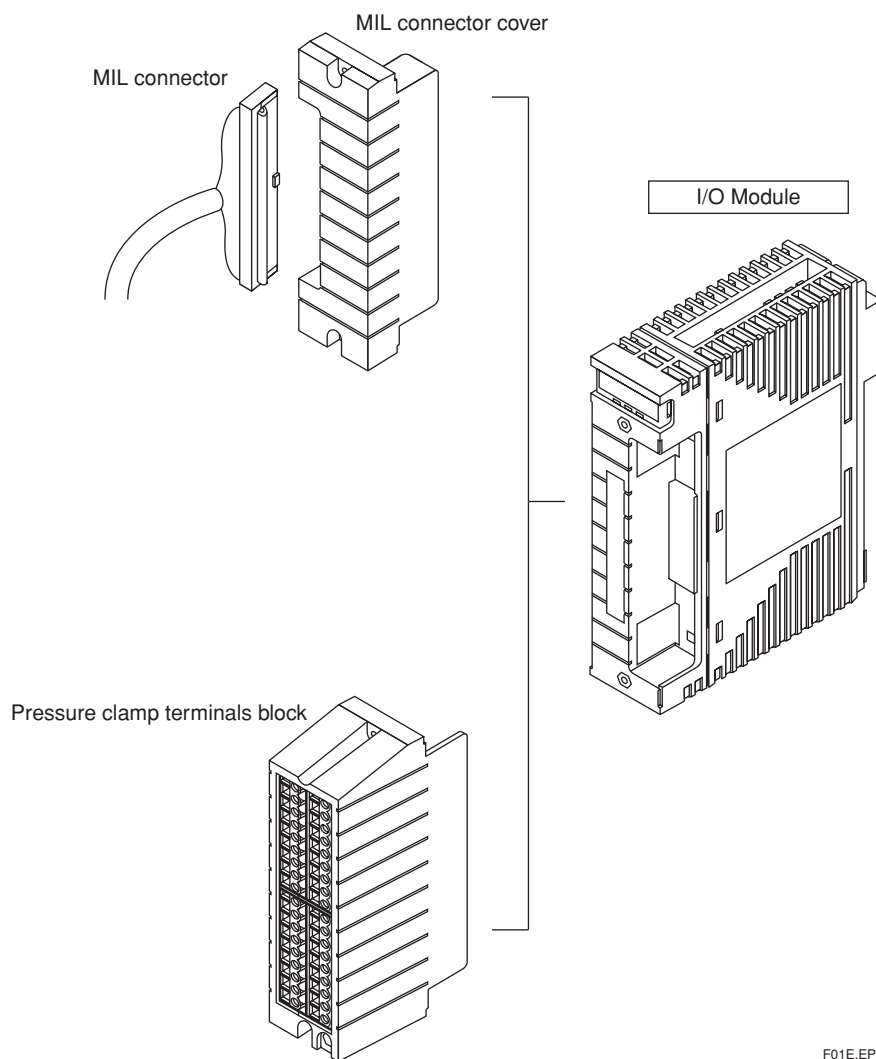

F01E.EPS

● Configuration of I/O Module Connection

A pressure clamp terminal block is provided for the terminal connection with field devices. When using a customer-supplied MIL connector cable, can directly connect to an I/O Module.

Table Combinations of I/O Modules and Terminal Blocks

Model name	Module name	Terminal block	MIL connector
—	Analog I/O Modules		
NFAI141	Analog Input Module (4 to 20 mA, 16-Channel, Non-Isolated)	NFTA4S	MIL 40 pins
NFAV141	Analog Input Module (1 to 5 V, 16-Channel, Non-Isolated)	NFTA4S	MIL 40 pins
NFAV142	Analog Input Module (-10 V to +10 V, 16-Channel, Non-Isolated)	NFTA4S	MIL 40 pins
NFAV144	Analog Input Module (-10 V to +10 V, 16-Channel, Isolated)	NFTA4S	MIL 40 pins
NFAI841	Analog I/O Module (4 to 20 mA Input, 4 to 20 mA Output, 8-Channel Input/8-Channel Output, Non-Isolated)	NFTA4S	MIL 40 pins
NFAB841	Analog I/O Module (1 to 5 V Input, 4 to 20 mA Output, 8-Channel Input/8-Channel Output, Non-Isolated)	NFTA4S	MIL 40 pins
NFAV542	Analog Output Module (-10 V to +10 V, 16-Channel, Non-Isolated)	NFTA4S	MIL 40 pins
NFAV544	Analog Output Module (-10 V to +10 V, 16-Channel, Isolated)	NFTA4S	MIL 40 pins
NFAI143	Analog Input Module (4 to 20 mA, 16-Channel, Isolated)	NFTA4S	MIL 40 pins
NFAI543	Analog Output Module (4 to 20 mA, 16-Channel, Isolated)	NFTA4S	MIL 40 pins
NFAT141	Thermocouple/mV Input Module (*1) (16-Channel, Isolated)	NFTT4S	MIL 40 pins (*1)
NFAR181	RTD Input Module (12-Channel, Isolated)	NFTR8S	-
NFAI135	Analog Input Module (4 to 20 mA, 8-Channel, Isolated Channels)	NFTI3S	MIL 40 pins
NFAI835	Analog I/O Module (4 to 20 mA, 4-Channel Input/4-Channel Output, Isolated Channels)	NFTI3S	MIL 40 pins
NFAP135	Pulse Input Module (8-Channel, Pulse Count, 0 to 10 kHz, Isolated Channels)	NFTI3S	MIL 40 pins
—	Digital I/O Modules		
NFDV151	Digital Input Module (32-Channel, 24 V DC)	NFTB5S	MIL 50 pins
NFDV157	Digital Input Module (32-Channel, 24 V DC, Pressure Clamp Terminal Support Only)	NFTC5S	-
NFDV141	Digital Input Module (16-Channel, 100 to 120 V AC)	NFTC4S-5	-
NFDV142	Digital Input Module (16-Channel, 200 to 220 V AC)	NFTC4S-6	-
NFDV161	Digital Input Module (64-Channel, 24 V DC)	-	MIL 50 pins x 2
NFDV532	Pulse Width Output Module (4-channel : Up Pulse/Down Pulse, 24 V DC, Isolated)	NFTD5S	MIL50 pins
NFDV551	Digital Output Module (32-Channel, 24 V DC)	NFTD5S	MIL 50 pins
NFDV557	Digital Output Module 32-Channel, 24 V DC, Pressure Clamp Terminal Support Only)	NFTC5S	-
NFDV561	Digital Output Module (64-Channel, 24 V DC)	-	MIL 50 pins x 2
NFDR541	Relay Output Module (16-Channel, 24 to 110 V DC, 100 to 240 V AC)	NFTC4S-7	-

T01E.EPS

*1: When a MIL connector cable is connected, the NFAT141 serves as a mV input module and no thermocouple signal can be connected.

Note: A cable connector cover (NFCCC01) is provided for the connection via a MIL connector.

■ SIGNAL CABLES (FOR TERMINAL BLOCK)

● Applicable Cables

Insulated cables for industrial equipment such as;

- 600 V polyvinyl chloride insulated wires (IV); JIS C3307
- Polyvinyl chloride insulated wires for electrical apparatus (KIV); JIS C3316
- 600 V grade heat-resistant polyvinyl chloride insulated wires (HIV); JIS C3317
- Heatproof vinyl insulated wires VW-1 (UL1015/UL1007)
- Control cables (vinyl insulated vinyl sheath cable) (CVV); JIS C3401

● Recommended Cable Thickness

Pressure clamp terminals

Without sleeve: 0.5 mm² to 2 mm² (AWG20 to 14)

With sleeve: 0.5 mm² to 1.5 mm² (AWG20 to 16)

● Cable Termination Process when Pressure Clamp Terminals Are Used

Without a Sleeve

Cable Thickness	Peel-off Length	Remark
0.5 mm ² to 2 mm ² (AWG20 to 14)	11 mm	Pressure clamp terminals other than below
1.25 mm ² to 2 mm ² (AWG16 to 14)	13 mm	When connecting with NFTC4S or NFTC5S

T02E.EPS

With a Sleeve

Table For NFTA4S, NFTB5S, NFTD5S, NFTI3S, NFTR8S and NFFT4S

Cable thickness	When using a sleeve with insulating cover				When using a sleeve (without insulating cover)		
	Peel-off length	Sleeve dimensions		Weidmuller model No.	Peel-off length	Sleeve dimensions	Weidmuller model No.
		Total length	Contact section length				
0.5 mm ²	11 mm	16 mm	10 mm	H0.5/16	11 mm	10 mm	H0.5/10
0.75 mm ²	11 mm	16 mm	10 mm	H0.75/16	11 mm	10 mm	H0.75/10
1.0 mm ²	11 mm	16 mm	10 mm	H1/16	11 mm	10 mm	H1/10
1.25 to 1.5 mm ²	11 mm	16 mm	10 mm	H1.5/16	11 mm	10 mm	H1.5/10

T03E.EPS

Table For NFTC4S and NFTC5S

Cable thickness	When using a sleeve with insulating cover				When using a sleeve (without insulating cover)		
	Peel-off length	Sleeve dimensions		Weidmuller model No.	Peel-off length	Sleeve dimensions	Weidmuller model No.
		Total length	Contact section length				
1.25 to 1.5 mm ²	13 mm	18 mm	12 mm	H1.5/18D	13 mm	12 mm	H1.5/12

T06E.EPS

■ SIGNAL CABLES (FOR MIL CONNECTOR CABLE CONNECTION)

● Applicable Connectors and Cables

Connector: MIL-C-83503-compliant, female 40- or 50-pin connector (*3)

Cable: Follows the specifications of the connector used.

Connector	Applicable Wires
Female crimping connector (*1)	AWG20 to 28 (or 0.5 to 0.08 mm ²)
Female insulation displacement connector (IDC) (*2)	AWG28 (or 0.08 mm ²), 1.27-mm pitch flat cable or equivalent AWG28 (or 0.08 mm ²), round fusion-splicing cable

T04E.EPS

*1: Use dedicated crimp-on socket contacts. Use of a hood is not allowed.

*2: Use of a strain relief is recommended.

*3: For a 50-pin MIL connector, use a model with two incorrect insertion prevention keys.

Use shielded cable containing twisted-pair conductors for analog signals.

For digital I/O signals, shielded cables are recommended.

● Connections

- After plugging into an I/O module, lock the cable's connector with a MIL connector cover (NFCCC01), except in the case of an NFDV161 or NFDV561 module.
- For an NFDV161 or NFDV561 module, use the connector lock levers to fix the connector.

■ TERMINAL BLOCK AND CONNECTOR CONNECTION SPECIFICATIONS

Please refer to the specifications shown below to connect signal cables with a proper terminal since some Analog I/O modules require to select a proper terminal dependent on the devices to be connected.

Model Name	Signal Name	I/O Signal		
NFAI141 NFAI841 NFAI143	IN□A	2-wire transmitter input +	Current input -	-
	IN□B	2-wire transmitter input - (setting pin: 2-wire input)	Current input + (setting pin: 4-wire input)	
NFAI135 NFAI835	IN□A	2-wire transmitter input +	-	-
	IN□B	2-wire transmitter input -	Current input +	
	IN□C	-	Current input -	
NFAR181	IN□A	Resistance temperature detector input A	-	-
	IN□B	Resistance temperature detector input B		
	IN□C	Resistance temperature detector input B		
NFAP135	IN□A	2-wire power supply source (+)	-	3-wire power supply source
	IN□B	2-wire power supply signal (-)	2-wire voltage, contact +	3-wire +
	IN□C	-	2-wire voltage, contact -	3-wire -

T05E.EPS

□ is channel number.

● Pin No. of MIL Connector

● Terminal No. of Pressure Clamp Terminal

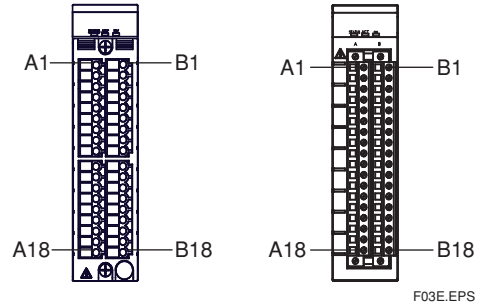
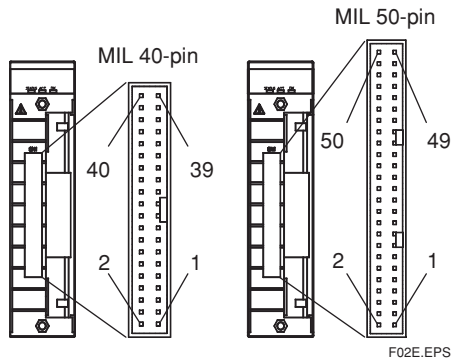

● MIL Cables (Straight Type) and General-purpose Terminal Blocks

When MIL cables (straight type) and general-purpose terminal blocks are used for input/output modules, the connectors of the input/output modules correspond to terminal numbers of the general-purpose terminal blocks as shown below. For customer-supplied MIL cables and terminal blocks, refer to the respective specifications carefully.

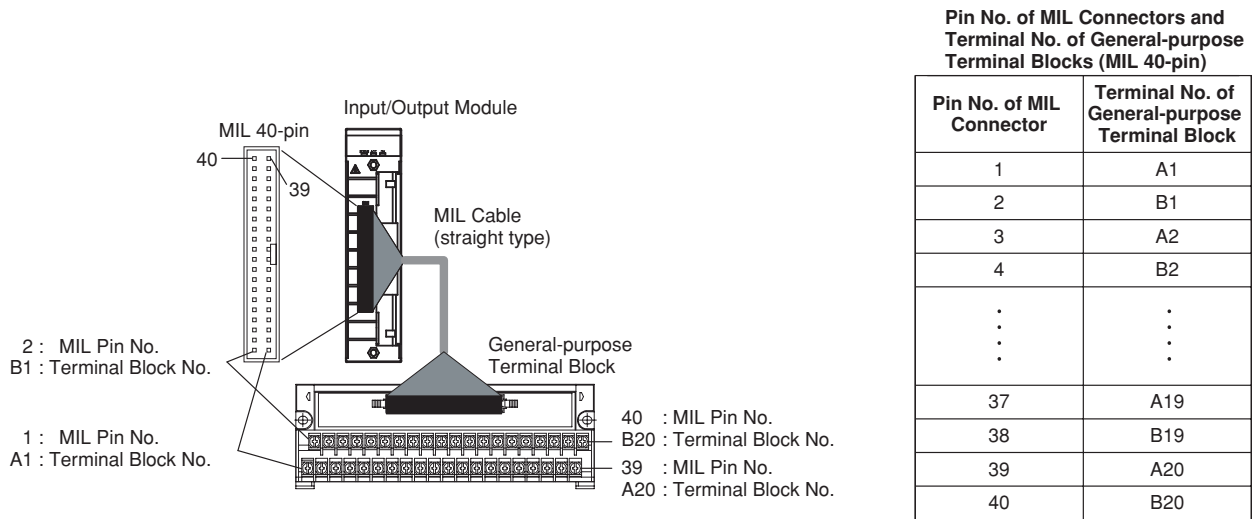

Figure Correspondence between the Signal Lines of MIL (40-pin) Connectors and Those of General-purpose Terminal Blocks

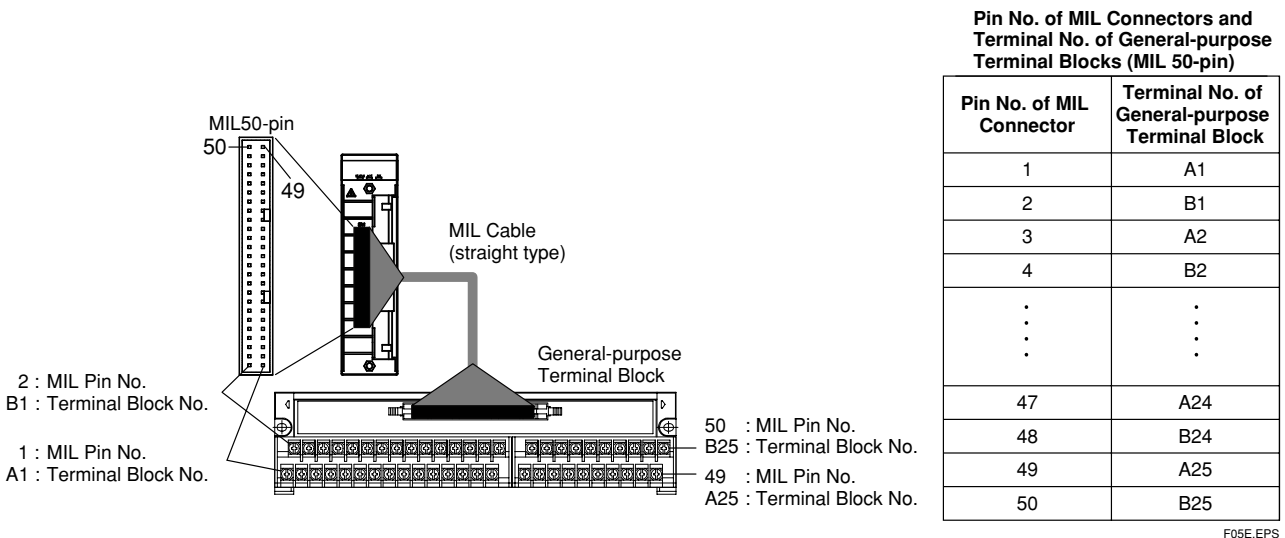

Figure Correspondence between the Signal Lines of MIL (50-pin) Connectors and Those of General-purpose Terminal Blocks

● NFAI141, NFAI143

• MIL Connector (Pin No./Signal Name)

Signal name	Pin No.		Signal name
IN1A	40	39	IN1B
IN2A	38	37	IN2B
IN3A	36	35	IN3B
IN4A	34	33	IN4B
IN5A	32	31	IN5B
IN6A	30	29	IN6B
IN7A	28	27	IN7B
IN8A	26	25	IN8B
IN9A	24	23	IN9B
IN10A	22	21	IN10B
IN11A	20	19	IN11B
IN12A	18	17	IN12B
IN13A	16	15	IN13B
IN14A	14	13	IN14B
IN15A	12	11	IN15B
IN16A	10	9	IN16B
N.C.	8	7	N.C.
N.C.	6	5	N.C.
N.C.	4	3	N.C.
CBSE(*1)	2	1	CBSE(*1)

F06E.EPS

*1: Short-circuit on CBSE terminals of the external terminal board so that disconnecter cable can be detected.

• Pressure clamp terminal (Terminal No./Signal Name)

Signal name	Terminal No.		Signal name
IN1A	A1	B1	IN1B
IN2A	A2	B2	IN2B
IN3A	A3	B3	IN3B
IN4A	A4	B4	IN4B
IN5A	A5	B5	IN5B
IN6A	A6	B6	IN6B
IN7A	A7	B7	IN7B
IN8A	A8	B8	IN8B
IN9A	A9	B9	IN9B
IN10A	A10	B10	IN10B
IN11A	A11	B11	IN11B
IN12A	A12	B12	IN12B
IN13A	A13	B13	IN13B
IN14A	A14	B14	IN14B
IN15A	A15	B15	IN15B
IN16A	A16	B16	IN16B
N.C.	A17	B17	N.C.
N.C.	A18	B18	N.C.

F07E.EPS

• General-purpose Terminal Blocks (Terminal No./Signal Name) (*2)

Signal Name	CBSE (*1)	N.C.	N.C.	N.C.	IN16A	IN15A	IN14A	IN13A	IN12A	IN11A	IN10A	IN9A	IN8A	IN7A	IN6A	IN5A	IN4A	IN3A	IN2A	IN1A
Terminal No.	B1	B2	B3	B4	B5	B6	B7	B8	B9	B10	B11	B12	B13	B14	B15	B16	B17	B18	B19	B20
Terminal No.	A1	A2	A3	A4	A5	A6	A7	A8	A9	A10	A11	A12	A13	A14	A15	A16	A17	A18	A19	A20
Signal Name	CBSE (*1)	N.C.	N.C.	N.C.	IN16B	IN15B	IN14B	IN13B	IN12B	IN11B	IN10B	IN9B	IN8B	IN7B	IN6B	IN5B	IN4B	IN3B	IN2B	IN1B

F08.EPS

*1: Short-circuit on CBSE terminals of the external terminal board so that disconnecter cable can be detected.
 *2: Correspondence between terminal numbers and signal names are examples of connections using MIL cables (straight type).

● NFAV141, NFAV142, NFAV144

• MIL Connector (Pin No./Signal Name)

Signal name	Pin No.		Signal name
IN1+	40	39	IN1-
IN2+	38	37	IN2-
IN3+	36	35	IN3-
IN4+	34	33	IN4-
IN5+	32	31	IN5-
IN6+	30	29	IN6-
IN7+	28	27	IN7-
IN8+	26	25	IN8-
IN9+	24	23	IN9-
IN10+	22	21	IN10-
IN11+	20	19	IN11-
IN12+	18	17	IN12-
IN13+	16	15	IN13-
IN14+	14	13	IN14-
IN15+	12	11	IN15-
IN16+	10	9	IN16-
N.C.	8	7	N.C.
N.C.	6	5	N.C.
N.C.	4	3	N.C.
CBSE(*1)	2	1	CBSE(*1)

F09E.EPS

*1: Short-circuit on CBSE terminals of the external terminal board so that disconnecter cable can be detected.

• Pressure clamp terminal (Terminal No./Signal Name)

Signal name	Terminal No.		Signal name
IN1+	A1	B1	IN1-
IN2+	A2	B2	IN2-
IN3+	A3	B3	IN3-
IN4+	A4	B4	IN4-
IN5+	A5	B5	IN5-
IN6+	A6	B6	IN6-
IN7+	A7	B7	IN7-
IN8+	A8	B8	IN8-
IN9+	A9	B9	IN9-
IN10+	A10	B10	IN10-
IN11+	A11	B11	IN11-
IN12+	A12	B12	IN12-
IN13+	A13	B13	IN13-
IN14+	A14	B14	IN14-
IN15+	A15	B15	IN15-
IN16+	A16	B16	IN16-
N.C.	A17	B17	N.C.
N.C.	A18	B18	N.C.

F10E.EPS

• General-purpose Terminal Blocks (Terminal No./Signal Name) (*2)

Signal Name	CBSE (*1)	N.C.	N.C.	N.C.	IN16+	IN15+	IN14+	IN13+	IN12+	IN11+	IN10+	IN9+	IN8+	IN7+	IN6+	IN5+	IN4+	IN3+	IN2+	IN1+
Terminal No.	B1	B2	B3	B4	B5	B6	B7	B8	B9	B10	B11	B12	B13	B14	B15	B16	B17	B18	B19	B20
Terminal No.	A1	A2	A3	A4	A5	A6	A7	A8	A9	A10	A11	A12	A13	A14	A15	A16	A17	A18	A19	A20
Signal Name	CBSE (*1)	N.C.	N.C.	N.C.	IN16-	IN15-	IN14-	IN13-	IN12-	IN11-	IN10-	IN9-	IN8-	IN7-	IN6-	IN5-	IN4-	IN3-	IN2-	IN1-

F11E.EPS

*1: Short-circuit on CBSE terminals of the external terminal board so that disconnecter cable can be detected.

*2: Correspondence between terminal numbers and signal names are examples of connections using MIL cables (straight type).

● NFAV542, NFAI543, NFAV544

• MIL Connector (Pin No./Signal Name)

Signal name	Pin No.		Signal name
OUT1+	40	39	OUT1-
OUT2+	38	37	OUT2-
OUT3+	36	35	OUT3-
OUT4+	34	33	OUT4-
OUT5+	32	31	OUT5-
OUT6+	30	29	OUT6-
OUT7+	28	27	OUT7-
OUT8+	26	25	OUT8-
OUT9+	24	23	OUT9-
OUT10+	22	21	OUT10-
OUT11+	20	19	OUT11-
OUT12+	18	17	OUT12-
OUT13+	16	15	OUT13-
OUT14+	14	13	OUT14-
OUT15+	12	11	OUT15-
OUT16+	10	9	OUT16-
N.C.	8	7	N.C.
N.C.	6	5	N.C.
N.C.	4	3	N.C.
CBSE(*1)	2	1	CBSE(*1)

F12E.EPS

*1: Short-circuit on CBSE terminals of the external terminal board so that disconnecter cable can be detected.

• Pressure clamp terminal (Terminal No./Signal Name)

Signal name	Terminal No.		Signal name
OUT1+	A1	B1	OUT1-
OUT2+	A2	B2	OUT2-
OUT3+	A3	B3	OUT3-
OUT4+	A4	B4	OUT4-
OUT5+	A5	B5	OUT5-
OUT6+	A6	B6	OUT6-
OUT7+	A7	B7	OUT7-
OUT8+	A8	B8	OUT8-
OUT9+	A9	B9	OUT9-
OUT10+	A10	B10	OUT10-
OUT11+	A11	B11	OUT11-
OUT12+	A12	B12	OUT12-
OUT13+	A13	B13	OUT13-
OUT14+	A14	B14	OUT14-
OUT15+	A15	B15	OUT15-
OUT16+	A16	B16	OUT16-
N.C.	A17	B17	N.C.
N.C.	A18	B18	N.C.

F13E.EPS

• General-purpose Terminal Blocks (Terminal No./Signal Name) (*2)

Signal Name	Terminal No.																			
CBSE (*1)	B1	B2	B3	B4	B5	B6	B7	B8	B9	B10	B11	B12	B13	B14	B15	B16	B17	B18	B19	B20
N.C.	A1	A2	A3	A4	A5	A6	A7	A8	A9	A10	A11	A12	A13	A14	A15	A16	A17	A18	A19	A20
N.C.	OUT16-	OUT15-	OUT14-	OUT13-	OUT12-	OUT11-	OUT10-	OUT9-	OUT8-	OUT7-	OUT6-	OUT5-	OUT4-	OUT3-	OUT2-	OUT1-				

F14E.EPS

*1: Short-circuit on CBSE terminals of the external terminal board so that disconnecter cable can be detected.
 *2: Correspondence between terminal numbers and signal names are examples of connections using MIL cables (straight type).

● NFAI841

• MIL Connector (Pin No./Signal Name)

Signal name	Pin No.		Signal name
IN1A	40	39	IN1B
IN2A	38	37	IN2B
IN3A	36	35	IN3B
IN4A	34	33	IN4B
IN5A	32	31	IN5B
IN6A	30	29	IN6B
IN7A	28	27	IN7B
IN8A	26	25	IN8B
OUT1+	24	23	OUT1-
OUT2+	22	21	OUT2-
OUT3+	20	19	OUT3-
OUT4+	18	17	OUT4-
OUT5+	16	15	OUT5-
OUT6+	14	13	OUT6-
OUT7+	12	11	OUT7-
OUT8+	10	9	OUT8-
N.C.	8	7	N.C.
N.C.	6	5	N.C.
N.C.	4	3	N.C.
CBSE(*1)	2	1	CBSE(*1)

F15E.EPS

*1: Short-circuit on CBSE terminals of the external terminal board so that disconnecter cable can be detected.

• Pressure clamp terminal (Terminal No./Signal Name)

Signal name	Terminal No.		Signal name
IN1A	A1	B1	IN1B
IN2A	A2	B2	IN2B
IN3A	A3	B3	IN3B
IN4A	A4	B4	IN4B
IN5A	A5	B5	IN5B
IN6A	A6	B6	IN6B
IN7A	A7	B7	IN7B
IN8A	A8	B8	IN8B
OUT1+	A9	B9	OUT1-
OUT2+	A10	B10	OUT2-
OUT3+	A11	B11	OUT3-
OUT4+	A12	B12	OUT4-
OUT5+	A13	B13	OUT5-
OUT6+	A14	B14	OUT6-
OUT7+	A15	B15	OUT7-
OUT8+	A16	B16	OUT8-
N.C.	A17	B17	N.C.
N.C.	A18	B18	N.C.

F16E.EPS

• General-purpose Terminal Blocks (Terminal No./Signal Name) (*2)

Signal Name	CBSE (*1)	N.C.	N.C.	N.C.	OUT8+	OUT7+	OUT6+	OUT5+	OUT4+	OUT3+	OUT2+	OUT1+	IN8A	IN7A	IN6A	IN5A	IN4A	IN3A	IN2A	IN1A
Terminal No.	B1	B2	B3	B4	B5	B6	B7	B8	B9	B10	B11	B12	B13	B14	B15	B16	B17	B18	B19	B20
Terminal No.	A1	A2	A3	A4	A5	A6	A7	A8	A9	A10	A11	A12	A13	A14	A15	A16	A17	A18	A19	A20
Signal Name	CBSE (*1)	N.C.	N.C.	N.C.	OUT8-	OUT7-	OUT6-	OUT5-	OUT4-	OUT3-	OUT2-	OUT1-	IN8B	IN7B	IN6B	IN5B	IN4B	IN3B	IN2B	IN1B

F17E.EPS

*1: Short-circuit on CBSE terminals of the external terminal board so that disconnecter cable can be detected.

*2: Correspondence between terminal numbers and signal names are examples of connections using MIL cables (straight type).

● NFAB841

• MIL Connector (Pin No./Signal Name)

Signal name	Pin No.		Signal name
IN1+	40	39	IN1-
IN2+	38	37	IN2-
IN3+	36	35	IN3-
IN4+	34	33	IN4-
IN5+	32	31	IN5-
IN6+	30	29	IN6-
IN7+	28	27	IN7-
IN8+	26	25	IN8-
OUT1+	24	23	OUT1-
OUT2+	22	21	OUT2-
OUT3+	20	19	OUT3-
OUT4+	18	17	OUT4-
OUT5+	16	15	OUT5-
OUT6+	14	13	OUT6-
OUT7+	12	11	OUT7-
OUT8+	10	9	OUT8-
N.C.	8	7	N.C.
N.C.	6	5	N.C.
N.C.	4	3	N.C.
CBSE(*1)	2	1	CBSE(*1)

F18E.EPS

*1: Short-circuit on CBSE terminals of the external terminal board so that disconnecter cable can be detected.

• Pressure clamp terminal (Terminal No./Signal Name)

Signal name	Terminal No.		Signal name
IN1+	A1	B1	IN1-
IN2+	A2	B2	IN2-
IN3+	A3	B3	IN3-
IN4+	A4	B4	IN4-
IN5+	A5	B5	IN5-
IN6+	A6	B6	IN6-
IN7+	A7	B7	IN7-
IN8+	A8	B8	IN8-
OUT1+	A9	B9	OUT1-
OUT2+	A10	B10	OUT2-
OUT3+	A11	B11	OUT3-
OUT4+	A12	B12	OUT4-
OUT5+	A13	B13	OUT5-
OUT6+	A14	B14	OUT6-
OUT7+	A15	B15	OUT7-
OUT8+	A16	B16	OUT8-
N.C.	A17	B17	N.C.
N.C.	A18	B18	N.C.

F19E.EPS

• General-purpose Terminal Blocks (Terminal No./Signal Name) (*2)

Signal Name	CBSE (*1)	N.C.	N.C.	N.C.	OUT8+	OUT7+	OUT6+	OUT5+	OUT4+	OUT3+	OUT2+	OUT1+	IN8+	IN7+	IN6+	IN5+	IN4+	IN3+	IN2+	IN1+
Terminal No.	B1	B2	B3	B4	B5	B6	B7	B8	B9	B10	B11	B12	B13	B14	B15	B16	B17	B18	B19	B20
Terminal No.	A1	A2	A3	A4	A5	A6	A7	A8	A9	A10	A11	A12	A13	A14	A15	A16	A17	A18	A19	A20
Signal Name	CBSE (*1)	N.C.	N.C.	N.C.	OUT8-	OUT7-	OUT6-	OUT5-	OUT4-	OUT3-	OUT2-	OUT1-	IN8-	IN7-	IN6-	IN5-	IN4-	IN3-	IN2-	IN1-

F20E.EPS

*1: Short-circuit on CBSE terminals of the external terminal board so that disconnecter cable can be detected.
 *2: Correspondence between terminal numbers and signal names are examples of connections using MIL cables (straight type).

● NFAT141

Note: When a MILL connector cable is connected, only the mV Input Module can be used.

• MIL Connector (Pin No./Signal Name)

Signal name	Pin No.		Signal name
IN1+	40	39	IN1-
IN2+	38	37	IN2-
IN3+	36	35	IN3-
IN4+	34	33	IN4-
IN5+	32	31	IN5-
IN6+	30	29	IN6-
IN7+	28	27	IN7-
IN8+	26	25	IN8-
IN9+	24	23	IN9-
IN10+	22	21	IN10-
IN11+	20	19	IN11-
IN12+	18	17	IN12-
IN13+	16	15	IN13-
IN14+	14	13	IN14-
IN15+	12	11	IN15-
IN16+	10	9	IN16-
Reserved	8	7	Reserved
Reserved	6	5	Reserved
Reserved	4	3	Reserved
CBSE(*1)	2	1	CBSE(*1)

F21E.EPS

• Pressure clamp terminal (Terminal No./Signal Name)

Signal name	Terminal No.		Signal name
IN1+	A1	B1	IN1-
IN2+	A2	B2	IN2-
IN3+	A3	B3	IN3-
IN4+	A4	B4	IN4-
IN5+	A5	B5	IN5-
IN6+	A6	B6	IN6-
IN7+	A7	B7	IN7-
IN8+	A8	B8	IN8-
IN9+	A9	B9	IN9-
IN10+	A10	B10	IN10-
IN11+	A11	B11	IN11-
IN12+	A12	B12	IN12-
IN13+	A13	B13	IN13-
IN14+	A14	B14	IN14-
IN15+	A15	B15	IN15-
IN16+	A16	B16	IN16-
N.C.	A17	B17	N.C.
N.C.	A18	B18	N.C.

F22E.EPS

*1: Short-circuit on CBSE terminals of the external terminal board so that disconnecter cable can be detected.

• General-purpose Terminal Blocks (Terminal No./Signal Name) (*2)

Signal Name	CBSE (*1)	Reserved	Reserved	Reserved	IN16+	IN15+	IN14+	IN13+	IN12+	IN11+	IN10+	IN9+	IN8+	IN7+	IN6+	IN5+	IN4+	IN3+	IN2+	IN1+
Terminal No.	B1	B2	B3	B4	B5	B6	B7	B8	B9	B10	B11	B12	B13	B14	B15	B16	B17	B18	B19	B20
Terminal No.	A1	A2	A3	A4	A5	A6	A7	A8	A9	A10	A11	A12	A13	A14	A15	A16	A17	A18	A19	A20
Signal Name	CBSE (*1)	Reserved	Reserved	Reserved	IN16-	IN15-	IN14-	IN13-	IN12-	IN11-	IN10-	IN9-	IN8-	IN7-	IN6-	IN5-	IN4-	IN3-	IN2-	IN1-

F23E.EPS

*1: Short-circuit on CBSE terminals of the external terminal board so that disconnecter cable can be detected.

*2: Correspondence between terminal numbers and signal names are examples of connections using MIL cables (straight type).

● NFAR181

- Pressure clamp terminal (Terminal No./Signal Name)

Signal name	Terminal No.		Signal name
IN1A	A1	B1	IN1C
IN1B	A2	B2	IN2B
IN2A	A3	B3	IN2C
IN3A	A4	B4	IN3C
IN3B	A5	B5	IN4B
IN4A	A6	B6	IN4C
IN5A	A7	B7	IN5C
IN5B	A8	B8	IN6B
IN6A	A9	B9	IN6C
IN7A	A10	B10	IN7C
IN7B	A11	B11	IN8B
IN8A	A12	B12	IN8C
IN9A	A13	B13	IN9C
IN9B	A14	B14	IN10B
IN10A	A15	B15	IN10C
IN11A	A16	B16	IN11C
IN11B	A17	B17	IN12B
IN12A	A18	B18	IN12C

F25E.EPS

● NFAI835

• MIL Connector (Pin No./Signal Name)

Signal name	Pin No.		Signal name
IN1A	40	39	N.C.
IN1B	38	37	IN1C
IN2A	36	35	N.C.
IN2B	34	33	IN2C
IN3A	32	31	N.C.
IN3B	30	29	IN3C
IN4A	28	27	N.C.
IN4B	26	25	IN4C
N.C.	24	23	N.C.
OUT1+	22	21	OUT1-
N.C.	20	19	N.C.
OUT2+	18	17	OUT2-
N.C.	16	15	N.C.
OUT3+	14	13	OUT3-
N.C.	12	11	N.C.
OUT4+	10	9	OUT4-
N.C.	8	7	N.C.
N.C.	6	5	N.C.
N.C.	4	3	N.C.
CBSE(*1)	2	1	CBSE(*1)

F27E.EPS

*1: Short-circuit on CBSE terminals of the external terminal board so that disconnecter cable can be detected.

• Pressure clamp terminal (Terminal No./Signal Name)

Signal name	Terminal No.		Signal name
IN1A	A1	B1	N.C.
IN1B	A2	B2	IN1C
IN2A	A3	B3	N.C.
IN2B	A4	B4	IN2C
IN3A	A5	B5	N.C.
IN3B	A6	B6	IN3C
IN4A	A7	B7	N.C.
IN4B	A8	B8	IN4C
N.C.	A9	B9	N.C.
OUT1+	A10	B10	OUT1-
N.C.	A11	B11	N.C.
OUT2+	A12	B12	OUT2-
N.C.	A13	B13	N.C.
OUT3+	A14	B14	OUT3-
N.C.	A15	B15	N.C.
OUT4+	A16	B16	OUT4-
N.C.	A17	B17	N.C.
N.C.	A18	B18	N.C.

F28E.EPS

• General-purpose Terminal Blocks (Terminal No./Signal Name) (*2)

Signal Name	CBSE (*1)	N.C.	N.C.	N.C.	OUT4+	N.C.	OUT3+	N.C.	OUT2+	N.C.	OUT1+	N.C.	IN4B	IN4A	IN3B	IN3A	IN2B	IN2A	IN1B	IN1A
Terminal No.	B1	B2	B3	B4	B5	B6	B7	B8	B9	B10	B11	B12	B13	B14	B15	B16	B17	B18	B19	B20
Terminal No.	A1	A2	A3	A4	A5	A6	A7	A8	A9	A10	A11	A12	A13	A14	A15	A16	A17	A18	A19	A20
Signal Name	CBSE (*1)	N.C.	N.C.	N.C.	OUT4-	N.C.	OUT3-	N.C.	OUT2-	N.C.	OUT1-	N.C.	IN4C	N.C.	IN3C	N.C.	IN2C	N.C.	IN1C	N.C.

F29E.EPS

*1: Short-circuit on CBSE terminals of the external terminal board so that disconnecter cable can be detected.
 *2: Correspondence between terminal numbers and signal names are examples of connections using MIL cables (straight type).

● NFAI135, NFAP135

• MIL Connector (Pin No./Signal Name)

Signal name	Pin No.		Signal name
IN1A	40	39	N.C.
IN1B	38	37	IN1C
IN2A	36	35	N.C.
IN2B	34	33	IN2C
IN3A	32	31	N.C.
IN3B	30	29	IN3C
IN4A	28	27	N.C.
IN4B	26	25	IN4C
IN5A	24	23	N.C.
IN5B	22	21	IN5C
IN6A	20	19	N.C.
IN6B	18	17	IN6C
IN7A	16	15	N.C.
IN7B	14	13	IN7C
IN8A	12	11	N.C.
IN8B	10	9	IN8C
N.C.	8	7	N.C.
N.C.	6	5	N.C.
N.C.	4	3	N.C.
CBSE(*1)	2	1	CBSE(*1)

F30E.EPS

*1: Short-circuit on CBSE terminals of the external terminal board so that disconnecter cable can be detected.

• Pressure clamp terminal (Terminal No./Signal Name)

Signal name	Terminal No.		Signal name
IN1A	A1	B1	N.C.
IN1B	A2	B2	IN1C
IN2A	A3	B3	N.C.
IN2B	A4	B4	IN2C
IN3A	A5	B5	N.C.
IN3B	A6	B6	IN3C
IN4A	A7	B7	N.C.
IN4B	A8	B8	IN4C
IN5A	A9	B9	N.C.
IN5B	A10	B10	IN5C
IN6A	A11	B11	N.C.
IN6B	A12	B12	IN6C
IN7A	A13	B13	N.C.
IN7B	A14	B14	IN7C
IN8A	A15	B15	N.C.
IN8B	A16	B16	IN8C
N.C.	A17	B17	N.C.
N.C.	A18	B18	N.C.

F31E.EPS

• General-purpose Terminal Blocks (Terminal No./Signal Name) (*2)

Signal Name	CBSE (*1)	N.C.	N.C.	N.C.	IN8B	IN8A	IN7B	IN7A	IN6B	IN6A	IN5B	IN5A	IN4B	IN4A	IN3B	IN3A	IN2B	IN2A	IN1B	IN1A
Terminal No.	B1	B2	B3	B4	B5	B6	B7	B8	B9	B10	B11	B12	B13	B14	B15	B16	B17	B18	B19	B20
Terminal No.	A1	A2	A3	A4	A5	A6	A7	A8	A9	A10	A11	A12	A13	A14	A15	A16	A17	A18	A19	A20
Signal Name	CBSE (*1)	N.C.	N.C.	N.C.	IN8C	N.C.	IN7C	N.C.	IN6C	N.C.	IN5C	N.C.	IN4C	N.C.	IN3C	N.C.	IN2C	N.C.	IN1C	N.C.

F32E.EPS

*1: Short-circuit on CBSE terminals of the external terminal board so that disconnecter cable can be detected.
 *2: Correspondence between terminal numbers and signal names are examples of connections using MIL cables (straight type).

● NFDV151

Note: NFDV151 is a sink/source-compatible input module. In case that the pressure clamp terminal block with a built-in surge absorber is used, the polarity of terminal COM1-16 (A17) and COM17-32 (B17) must be the same.

• Pressure clamp terminal (Terminal No./Signal Name)

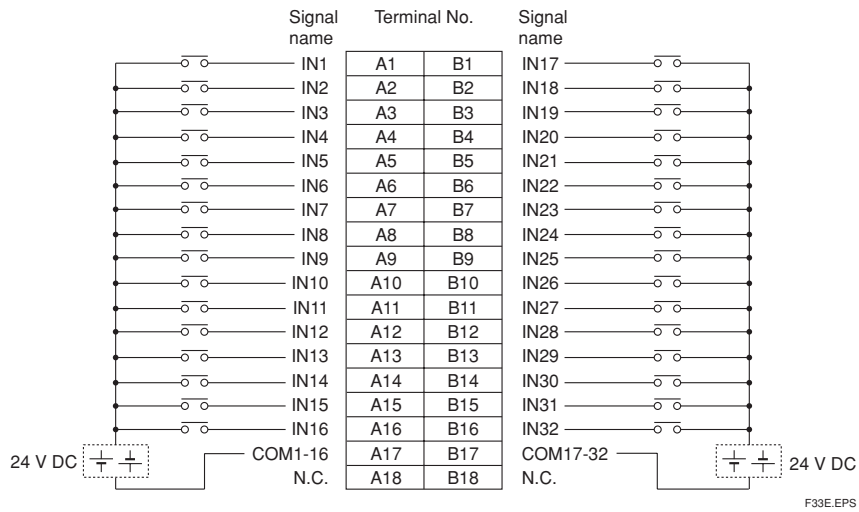

• MIL Connector (Pin No./Signal Name)

Signal name	Pin No.	Signal name
IN1	50	IN17
IN2	48	IN18
IN3	46	IN19
IN4	44	IN20
IN5	42	IN21
IN6	40	IN22
IN7	38	IN23
IN8	36	IN24
IN9	34	IN25
IN10	32	IN26
IN11	30	IN27
IN12	28	IN28
IN13	26	IN29
IN14	24	IN30
IN15	22	IN31
IN16	20	IN32
COM1-16	18	COM17-32
COM1-16	16	COM17-32
COM1-16	14	COM17-32
COM1-16	12	COM17-32
N.C.	10	N.C.
N.C.	8	N.C.
N.C.	6	N.C.
N.C.	4	N.C.
CBSE(*1)	2	CBSE(*1)

*1: Short-circuit on CBSE terminals of the external terminal board so that disconnecter cable can be detected.

• General-purpose Terminal Blocks (Terminal No./Signal Name) (*2) (NFDV151)

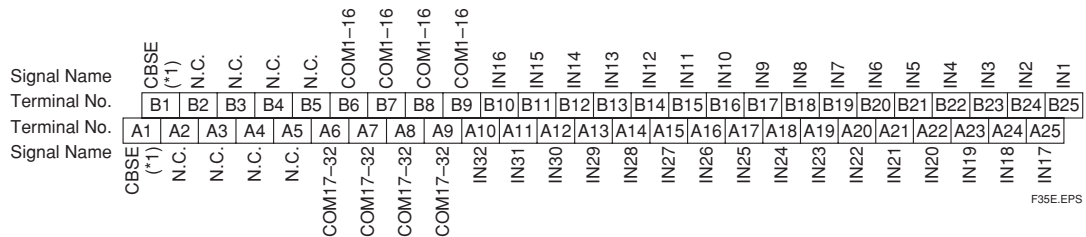

*1: Short-circuit on CBSE terminals of the external terminal board so that disconnecter cable can be detected.

*2: Correspondence between terminal numbers and signal names are examples of connections using MIL cables (straight type).

Note: For the method of external wiring, please refer to pressure clamp terminal section.

● **NFDV157**

Note: MIL connector connection cannot be used.

- **Pressure clamp terminal (Terminal No./Signal Name)**

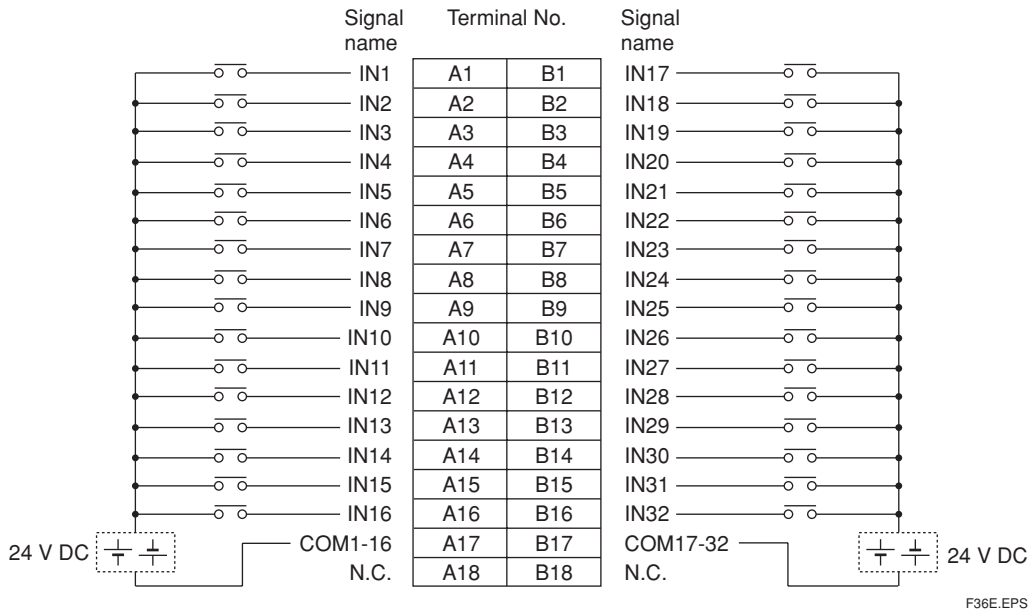

● **NFDV141, NFDV142**

Note: MIL connector connection cannot be used.

- **Pressure clamp terminal (Terminal No./Signal Name)**

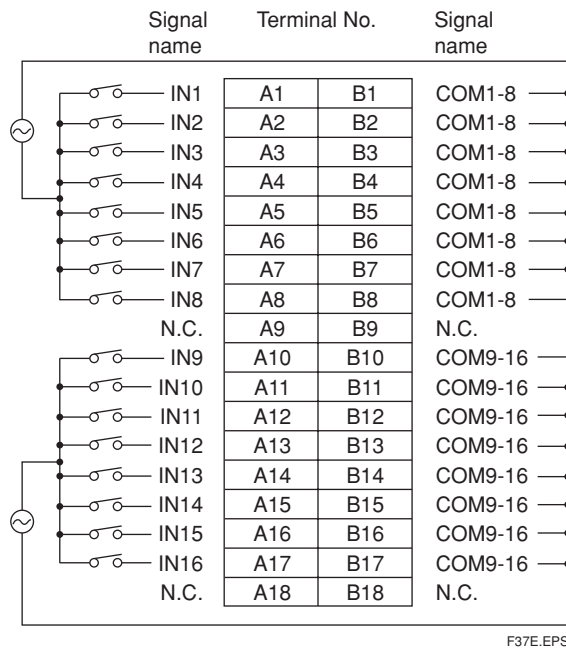

● **NFDV161**

- Note:
- 2 sets of a general-purpose terminal block and a MIL cable are used.
 - Pressure clamp terminal connection cannot be used.
 - For the method of external wiring, please refer to NFDV151 of pressure clamp terminal.

• **MIL Connector (Pin No./Signal Name)**

[CN1]			[CN2]			
Signal name	Pin No.		Signal name	Pin No.		Signal name
IN1	50	49	IN17	50	49	IN49
IN2	48	47	IN18	48	47	IN50
IN3	46	45	IN19	46	45	IN51
IN4	44	43	IN20	44	43	IN52
IN5	42	41	IN21	42	41	IN53
IN6	40	39	IN22	40	39	IN54
IN7	38	37	IN23	38	37	IN55
IN8	36	35	IN24	36	35	IN56
IN9	34	33	IN25	34	33	IN57
IN10	32	31	IN26	32	31	IN58
IN11	30	29	IN27	30	29	IN59
IN12	28	27	IN28	28	27	IN60
IN13	26	25	IN29	26	25	IN61
IN14	24	23	IN30	24	23	IN62
IN15	22	21	IN31	22	21	IN63
IN16	20	19	IN32	20	19	IN64
COM1-16	18	17	COM17-32	18	17	COM49-64
COM1-16	16	15	COM17-32	16	15	COM49-64
COM1-16	14	13	COM17-32	14	13	COM49-64
COM1-16	12	11	COM17-32	12	11	COM49-64
N.C.	10	9	N.C.	10	9	N.C.
N.C.	8	7	N.C.	8	7	N.C.
N.C.	6	5	N.C.	6	5	N.C.
N.C.	4	3	N.C.	4	3	N.C.
CBSE(*1)	2	1	CBSE(*1)	2	1	CBSE(*1)

F38E.EPS

*1: Short-circuit on CBSE terminals of the external terminal board so that disconnecter cable can be detected.

• **General-purpose Terminal Blocks (Terminal No./Signal Name) (*2)**

[CN1]

Signal Name	Terminal No.																								
Terminal No.	B1	B2	B3	B4	B5	B6	B7	B8	B9	B10	B11	B12	B13	B14	B15	B16	B17	B18	B19	B20	B21	B22	B23	B24	B25
Signal Name	CBSE(*1)	N.C.	N.C.	N.C.	N.C.	COM17-32	COM17-32	COM17-32	COM17-32	IN32	IN31	IN30	IN29	IN28	IN27	IN26	IN25	IN24	IN23	IN22	IN21	IN20	IN19	IN18	IN17
	CBSE(*1)	N.C.	N.C.	N.C.	N.C.	COM1-16	COM1-16	COM1-16	COM1-16	IN16	IN15	IN14	IN13	IN12	IN11	IN10	IN9	IN8	IN7	IN6	IN5	IN4	IN3	IN2	IN1

F39E.EPS

[CN2]

Signal Name	Terminal No.																								
Terminal No.	A1	A2	A3	A4	A5	A6	A7	A8	A9	A10	A11	A12	A13	A14	A15	A16	A17	A18	A19	A20	A21	A22	A23	A24	A25
Signal Name	CBSE(*1)	N.C.	N.C.	N.C.	N.C.	COM49-64	COM49-64	COM49-64	COM49-64	IN64	IN63	IN62	IN61	IN60	IN59	IN58	IN57	IN56	IN55	IN54	IN53	IN52	IN51	IN50	IN49
	CBSE(*1)	N.C.	N.C.	N.C.	N.C.	COM33-48	COM33-48	COM33-48	COM33-48	IN48	IN47	IN46	IN45	IN44	IN43	IN42	IN41	IN40	IN39	IN38	IN37	IN36	IN35	IN34	IN33

F40E.EPS

*1: Short-circuit on CBSE terminals of the external terminal board so that disconnecter cable can be detected.

*2: Correspondence between terminal numbers and signal names are examples of connections using MIL cables (straight type).

● **NFDV532**

Note: Please connect the plus side of a field power supply to 24V DC, and connect a minus side to COM.

• **Pressure clamp terminal (Terminal No./Signal Name)**

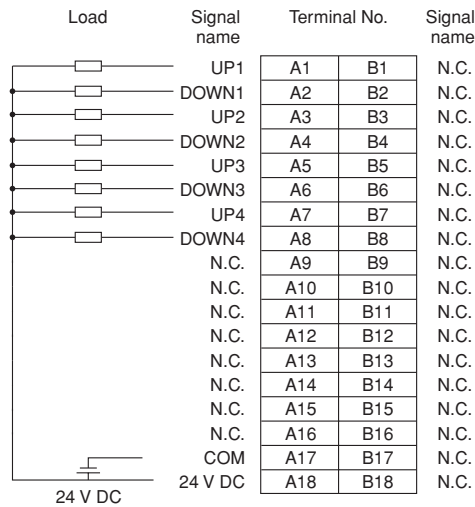

F51E.EPS

• **MIL Connector (Pin No./Signal Name)**

Signal name	Pin No.	Signal name
UP1	50 49	N.C.
DOWN1	48 47	N.C.
UP2	46 45	N.C.
DOWN2	44 43	N.C.
UP3	42 41	N.C.
DOWN3	40 39	N.C.
UP4	38 37	N.C.
DOWN4	36 35	N.C.
N.C.	34 33	N.C.
N.C.	32 31	N.C.
N.C.	30 29	N.C.
N.C.	28 27	N.C.
N.C.	26 25	N.C.
N.C.	24 23	N.C.
N.C.	22 21	N.C.
N.C.	20 19	N.C.
COM	18 17	N.C.
COM	16 15	N.C.
COM	14 13	N.C.
COM	12 11	N.C.
24 V DC	10 9	N.C.
24 V DC	8 7	N.C.
N.C.	6 5	N.C.
N.C.	4 3	N.C.
CBSE(*1)	2 1	CBSE(*1)

F52E.EPS

*1: Short-circuit on CBSE terminals of the external terminal board so that disconnecter cable can be detected.

• **General-purpose Terminal Blocks (Terminal No./Signal Name) (*2) (NFDV532)**

Signal Name	Terminal No.	Terminal No.	Signal Name
CBSE(*1)	B1	A1	CBSE(*1)
N.C.	B2	A2	N.C.
N.C.	B3	A3	N.C.
24 V DC	B4	A4	N.C.
24 V DC	B5	A5	N.C.
COM	B6	A6	N.C.
COM	B7	A7	N.C.
COM	B8	A8	N.C.
COM	B9	A9	N.C.
N.C.	B10	A10	N.C.
N.C.	B11	A11	N.C.
N.C.	B12	A12	N.C.
N.C.	B13	A13	N.C.
N.C.	B14	A14	N.C.
N.C.	B15	A15	N.C.
N.C.	B16	A16	N.C.
N.C.	B17	A17	N.C.
N.C.	B18	A18	N.C.
DOWN4	B19	A19	N.C.
UP4	B20	A20	N.C.
DOWN3	B21	A21	N.C.
UP3	B22	A22	N.C.
DOWN2	B23	A23	N.C.
UP2	B24	A24	N.C.
DOWN1	B25	A25	N.C.
UP1			N.C.

F53E.EPS

*1: Short-circuit on CBSE terminals of the external terminal board so that disconnecter cable can be detected.

*2: Correspondence between terminal numbers and signal names are examples of connections using MIL cables (straight type).

● **NFDV551**

Note: Please connect the plus side of a field power supply to 24V DC, and connect a minus side to COM 1-16 and COM 17-32.

• **Pressure clamp terminal (Terminal No./Signal Name)**

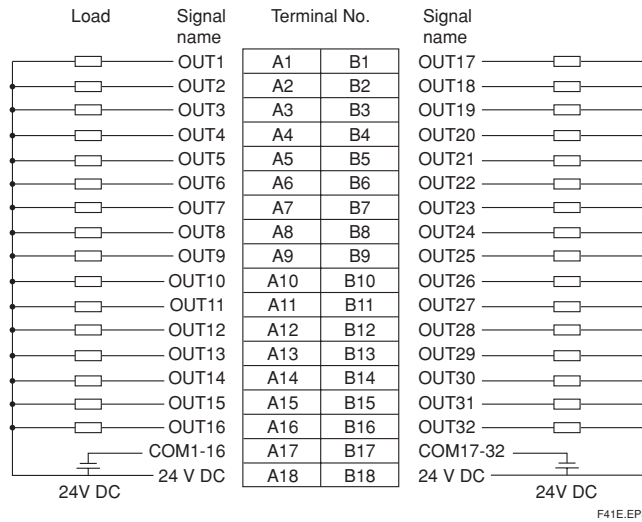

F41E.EPS

• **MIL Connector (Pin No./Signal Name)**

Signal name	Pin No.	Signal name
OUT1	50 49	OUT17
OUT2	48 47	OUT18
OUT3	46 45	OUT19
OUT4	44 43	OUT20
OUT5	42 41	OUT21
OUT6	40 39	OUT22
OUT7	38 37	OUT23
OUT8	36 35	OUT24
OUT9	34 33	OUT25
OUT10	32 31	OUT26
OUT11	30 29	OUT27
OUT12	28 27	OUT28
OUT13	26 25	OUT29
OUT14	24 23	OUT30
OUT15	22 21	OUT31
OUT16	20 19	OUT32
COM1-16	18 17	COM17-32
COM1-16	16 15	COM17-32
COM1-16	14 13	COM17-32
COM1-16	12 11	COM17-32
24 V DC	10 9	24 V DC
24 V DC	8 7	24 V DC
N.C.	6 5	N.C.
N.C.	4 3	N.C.
CBSE(*1)	2 1	CBSE(*1)

F42E.EPS

*1: Short-circuit on CBSE terminals of the external terminal board so that disconnecter cable can be detected.

• **General-purpose Terminal Blocks (Terminal No./Signal Name) (*2) (NFDV551)**

Signal Name	CBSE (*1)	N.C.	N.C.	24 V DC	24 V DC	COM1-16	COM1-16	COM1-16	COM1-16	OUT16	OUT15	OUT14	OUT13	OUT12	OUT11	OUT10	OUT9	OUT8	OUT7	OUT6	OUT5	OUT4	OUT3	OUT2	OUT1
Terminal No.	B1	B2	B3	B4	B5	B6	B7	B8	B9	B10	B11	B12	B13	B14	B15	B16	B17	B18	B19	B20	B21	B22	B23	B24	B25
Terminal No.	A1	A2	A3	A4	A5	A6	A7	A8	A9	A10	A11	A12	A13	A14	A15	A16	A17	A18	A19	A20	A21	A22	A23	A24	A25
Signal Name	CBSE (*1)	N.C.	N.C.	24 V DC	24 V DC	COM17-32	COM17-32	COM17-32	COM17-32	OUT32	OUT31	OUT30	OUT29	OUT28	OUT27	OUT26	OUT25	OUT24	OUT23	OUT22	OUT21	OUT20	OUT19	OUT18	OUT17

F43E.EPS

*1: Short-circuit on CBSE terminals of the external terminal board so that disconnecter cable can be detected.

*2: Correspondence between terminal numbers and signal names are examples of connections using MIL cables (straight type).

● **NFDV557**

Note: • Please connect the plus side of a field power supply to 24V DC, and connect a minus side to COM 1-16 and COM 17-32.
 • MIL connector connection cannot be used.

• **Pressure clamp terminal (Terminal No./Signal Name)**

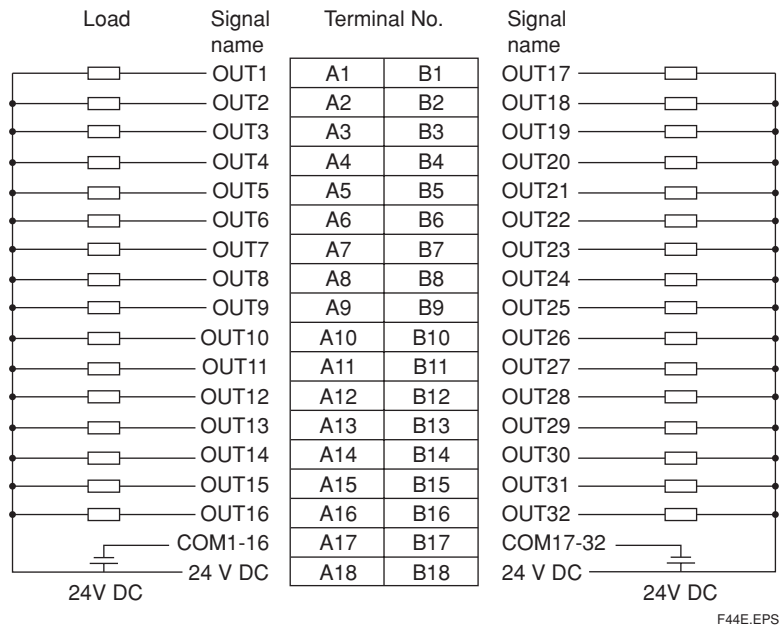

● NFDV561

- Note:
- 2 sets of a general-purpose terminal block and a MIL cable are used.
 - Pressure clamp terminal connection cannot be used.
 - For the method of external wiring, please refer to NFDV551 of pressure clamp terminal.

• MIL Connector(Pin No./Signal Name)

[CN1]			[CN2]			
Signal name	Pin No.		Signal name	Pin No.		Signal name
OUT1	50	49	OUT17	50	49	OUT49
OUT2	48	47	OUT18	48	47	OUT50
OUT3	46	45	OUT19	46	45	OUT51
OUT4	44	43	OUT20	44	43	OUT52
OUT5	42	41	OUT21	42	41	OUT53
OUT6	40	39	OUT22	40	39	OUT54
OUT7	38	37	OUT23	38	37	OUT55
OUT8	36	35	OUT24	36	35	OUT56
OUT9	34	33	OUT25	34	33	OUT57
OUT10	32	31	OUT26	32	31	OUT58
OUT11	30	29	OUT27	30	29	OUT59
OUT12	28	27	OUT28	28	27	OUT60
OUT13	26	25	OUT29	26	25	OUT61
OUT14	24	23	OUT30	24	23	OUT62
OUT15	22	21	OUT31	22	21	OUT63
OUT16	20	19	OUT32	20	19	OUT64
COM1-16	18	17	COM17-32	18	17	COM49-64
COM1-16	16	15	COM17-32	16	15	COM49-64
COM1-16	14	13	COM17-32	14	13	COM49-64
COM1-16	12	11	COM17-32	12	11	COM49-64
24 V DC	10	9	24 V DC	10	9	24 V DC
24 V DC	8	7	24 V DC	8	7	24 V DC
N.C.	6	5	N.C.	6	5	N.C.
N.C.	4	3	N.C.	4	3	N.C.
CBSE(*1)	2	1	CBSE(*1)	2	1	CBSE(*1)

F46E.EPS

*1: Short-circuit on CBSE terminals of the external terminal board so that disconnecter cable can be detected.

• General-purpose Terminal Blocks (Terminal No./Signal Name) (*2)

[CN1]

Signal Name	CBSE (*1)	N.C.	N.C.	24 V DC	24 V DC	COM1-16	COM1-16	COM1-16	COM1-16	OUT16	OUT15	OUT14	OUT13	OUT12	OUT11	OUT10	OUT9	OUT8	OUT7	OUT6	OUT5	OUT4	OUT3	OUT2	OUT1
Terminal No.	B1	B2	B3	B4	B5	B6	B7	B8	B9	B10	B11	B12	B13	B14	B15	B16	B17	B18	B19	B20	B21	B22	B23	B24	B25
Terminal No.	A1	A2	A3	A4	A5	A6	A7	A8	A9	A10	A11	A12	A13	A14	A15	A16	A17	A18	A19	A20	A21	A22	A23	A24	A25
Signal Name	CBSE (*1)	N.C.	N.C.	24 V DC	24 V DC	COM17-32	COM17-32	COM17-32	COM17-32	OUT32	OUT31	OUT30	OUT29	OUT28	OUT27	OUT26	OUT25	OUT24	OUT23	OUT22	OUT21	OUT20	OUT19	OUT18	OUT17

F46E.EPS

[CN2]

Signal Name	CBSE (*1)	N.C.	N.C.	24 V DC	24 V DC	COM33-48	COM33-48	COM33-48	COM33-48	OUT48	OUT47	OUT46	OUT45	OUT44	OUT43	OUT42	OUT41	OUT40	OUT39	OUT38	OUT37	OUT36	OUT35	OUT34	OUT33
Terminal No.	B1	B2	B3	B4	B5	B6	B7	B8	B9	B10	B11	B12	B13	B14	B15	B16	B17	B18	B19	B20	B21	B22	B23	B24	B25
Terminal No.	A1	A2	A3	A4	A5	A6	A7	A8	A9	A10	A11	A12	A13	A14	A15	A16	A17	A18	A19	A20	A21	A22	A23	A24	A25
Signal Name	CBSE (*1)	N.C.	N.C.	24 V DC	24 V DC	COM49-64	COM49-64	COM49-64	COM49-64	OUT64	OUT63	OUT62	OUT61	OUT60	OUT59	OUT58	OUT57	OUT56	OUT55	OUT54	OUT53	OUT52	OUT51	OUT50	OUT49

F47E.EPS

- *1: Short-circuit on CBSE terminals of the external terminal board so that disconnecter cable can be detected.
 *2: Correspondence between terminal numbers and signal names are examples of connections using MIL cables (straight type).

● **NFDR541**

Note: MIL connector connection cannot be used.

• **Pressure clamp terminal (Terminal No./Signal Name)**

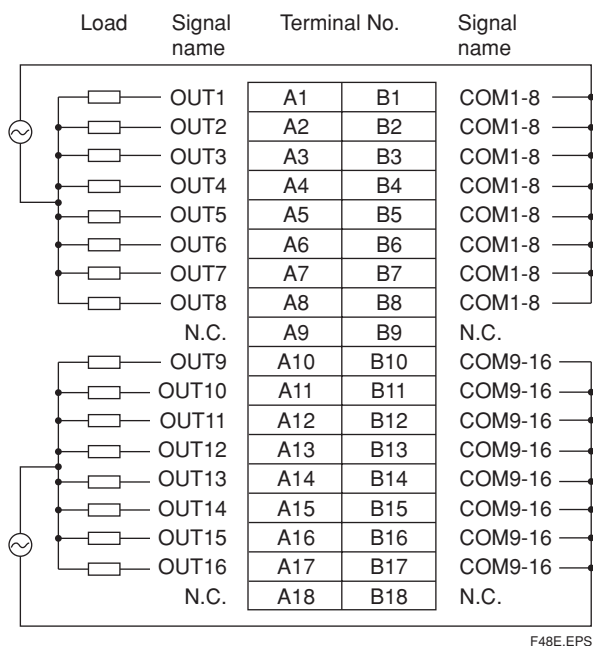

SERIAL COMMUNICATION MODULES

NFLR111 RS-232-C Communication Module

Connectors (D-sub 9-pin, female) (*1)

Pin No.	Abbreviation	Signal Name	Function
1	CD	Carrier Detect	Data channel reception Carrier detection
2	RD	Received Data	Data reception
3	SD	Send Data	Data transmission
4	ER	Equipment Ready	Data equipment ready
5	SG	Signal Ground	Signal grounding
6	DR	Dataset Ready	Dataset ready
7	RS	Request to Send	Request for transmission
8	CS	Clear to Send	Transmission is allowed
9	-	-	N.C.

T07E.EPS

*1: Connectors are fastened using metric screw threads (M2.6).

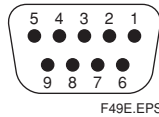

F49E.EPS

Figure Pin No. of Connectors On the D-sub 9-pin Module

Cables (Examples) for NFLR111 RS-232-C Communication Modules (*1) (*2)

Model Name	Function
AKB131	RS-232-C modem cable for connecting RS circuit isolation equipment 9 to 25 pins for start-stop synchronization communication
AKB132	RS-232-C null modem cable for connecting RS circuit isolation equipment 9 to 25 pins for start-stop synchronization communication
AKB133	RS-232-C null modem cable 9 to 9 pins (male) for start-stop synchronization communication
AKB135	RS-232-C modem cable 9 to 25 pins for start-stop synchronization communication
AKB136	RS-232-C null modem cable 9 to 25 pins for start-stop synchronization communication

T08E.EPS

*1: For cables, refer to TI 34P02Q91-01E ("FCN/FCJ Installation Guide").

*2: For specifications of cables, refer to GS 33Q06R10-31E ("Cables").
ALR111 cables can be used for NFLR111.

NFLR121 RS-422/RS-485 Communication Module Terminal Block (M4 Screws)

Terminal Symbol	Signal Name	Function
TX+	Send Data	Data transmission (common mode signal)
TX-	Send Data	Data transmission (reverse phase signal)
RX+	Received Data	Data reception (common mode signal)
RX-	Received Data	Data reception (reverse phase signal)
SG	Signal Ground	Signal grounding

T09E.EPS

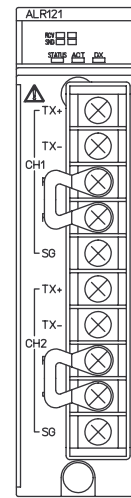

F50E.EPS

Figure Terminal Symbols for RS-422/RS-485 Communication Module

Cables (Examples) for NFLR121 RS-422/RS-485 Communication Modules (*1) (*2)

Model Name	Function
AKB161	Dedicated cable between NFLR121 and FA500, up to 100 m
AKB162	Dedicated cable between NFLR121 and FA-M3, up to 100 m

T10E.EPS

*1: For cables, refer to TI 34P02Q91-01E ("FCN/FCJ Installation Guide").

*2: For cables, refer to GS 33Y06L10-31E ("Cables").
ACM12 cables can be used for NFLR121.

TRADEMARK

- STARDOM is a trademark.
- Other company and product names appearing in this document are trademarks or registered trademarks of their respective holders.