

For correct and safe use of transducers, read this manual thoroughly. Store this manual in an accessible place so that it can be referred to as necessary.

1. Prior to Mounting

- (1) Check the appearance of the packing box and transducer case and confirm that there is no damage.
- (2) Check the description written on the specification plate attached to the side of the transducer to ensure the device is exactly as ordered.

2. Mounting Method

This product can be mounted on either a panel or DIN rail (36 mm).

If more than one transducer is to be mounted, ensure that there is a space of at least 5 mm between two units.

- (1) For panel mounting, fix the transducer in place with two M6 screws as shown in Figure 1. The lower mounting tab has a notch instead of a screw hole to increase the ease of mounting. First, partially tighten the lower screw as shown in Figure 2; then, slide the tab of the transducer so that the screw is situated between the notch. This allows the transducer to be easily mounted by merely tightening the upper screw.

Recommended tightening torque for M6 screws: 3.2 N·m

- (2) DIN rail mounting (removal)

The transducer can be mounted by first hanging the upper groove on the DIN rail and then pushing the lower part of the transducer until the rail is in place in the lower groove as shown in Figure 3. If the transducer is to be moved or removed, use a flat-blade screwdriver to slide the slide lock as shown in Figure 4.

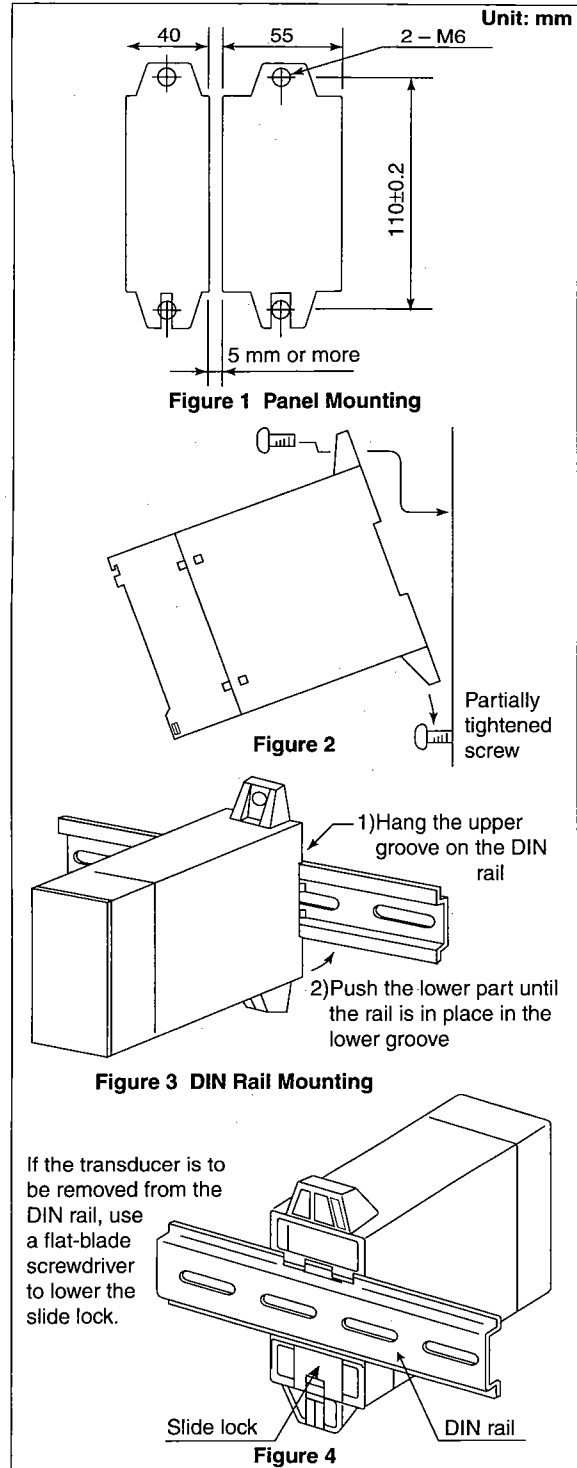

3. Wiring

Perform wiring after confirming that each wire is disconnected from the power source.

(1) Removal and mounting of safety terminal cover

When the safety terminal cover is to be removed (opened) so that wiring can be performed, hold it just above its center and gently pull. The cover will bend enough to release the upper part and allow the cover to be removed.

Do not use excessive force when pulling the cover as this may result in it being broken.
Do not remove the lower part of the cover unless necessary as it may be lost.

When the cover is to be mounted (closed), do it in the reverse order of the procedure for removal.

(2) Screw-up system

A spring-loaded captive screws are used for the terminals of this product, where the screws lift only by being loosened to allow wiring with ring-tongue terminal lugs. These screws shorten the amount of time needed for wiring as all that is required is to tighten them while pressing on them and there is no risk of screws and spring washers coming undone easily.

Do not unnecessarily turn the screws counterclockwise while the screws are lifted as this may result in them coming out.

Recommended tightening torque for M4 terminal screws: 1.2 N•m

(3) Perform wiring in accordance with the wiring diagram in the catalog or as shown on the side of the transducer. These diagrams show an external CT or VT for every type of AC input; however, when directly connecting the input, ignore the CT or VT and connect the wires to the transducer. In this case, the grounding of the secondary wire from the CT or VT (for stabilizing the electric potential) is not needed.

Example 1: No external CT

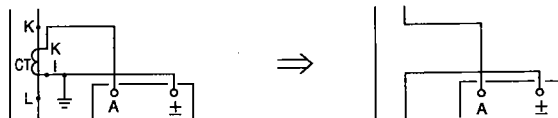

Example 2: No external VT

