

Thank you for purchasing the CA12E HANDY CAL. Prior to using, read this User's Manual carefully to fully and properly utilize all of the features of this instrument. Also, refer as needed to IM CA12E-02E, an additional User's Manual for this instrument.



Yokogawa Meters & Instruments Corporation

IM CA12E-01E  
3rd Edition Sep. 2009 (KP)

### 1. Safety Precautions

When operating the instrument, strictly observe the precautions below to ensure its correct and safe operation. If used other than as instructed in this manual, Yokogawa Meters & Instruments Corporation is not liable for any damage that may result.

#### The following safety symbols are used on the instrument and in the manual:

- Danger! Handle with care. This symbol indicates that the operator must refer to an explanation in the User's Manual in order to avoid risk of injury or death of personnel or damage to the instrument.
- WARNING** Indicates a hazard that may result in the loss of life or serious injury of the user unless the described instruction is abided by.
- CAUTION** Indicates a hazard that may result in an injury to the user and/or physical damage to the product or other equipment unless the described instruction is abided by.
- NOTE** Indicates information that is essential for handling the instrument or, should be noted in order to familiarize yourself with the instrument's operating procedures and/or functions.

#### Damage to the instrument, personal injury or even death may result from electrical shock or other factors. To avoid this, follow the precautions below:



- **Use where gases may be present**  
Do not operate the instrument in a location where flammable or explosive gas/vapor present. It is extremely hazardous to operate the instrument in such an atmosphere.
- **External connection**  
If necessary to touch a circuit to make an external connection, turn off the power to that circuit, ensure there is no voltage, then perform the connection. When replacing the batteries, disconnect the lead cables in advance.
- **Disassembly**  
Do not disassemble or remodel the instrument yourself. This needs to be done by our service personnel.

### 2. Names and Functions of Parts

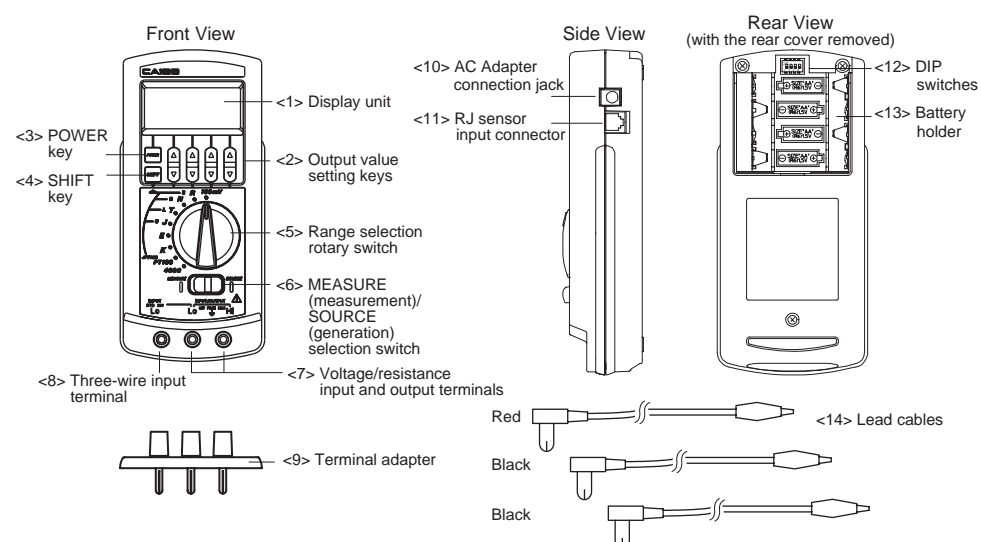

#### <1> Display unit

- a. MEASURE  
Lights up when MEASURE (measurement) is selected using the selection switch <6>.
- b. SOURCE  
Lights up when SOURCE (generation) is selected using the selection switch <6>.
- c. CAL  
Lights up in the calibration mode.
- d. 0/FS  
Lights up or blinks when offset or full-scale adjustment is performed in the calibration mode.
- e.   
This mark indicates the battery's status. When lit, it indicates the batteries will soon need replacing. When blinking, it indicates that they must be replaced (see Section 3, "Replacing Batteries").
- f. Main Seven Segment  
Displays a measured value or an output value.
- g. Sub Seven Segment  
<PT100 range> When IPTS68 is selected by DIP switch 3, 68 is displayed.  
<Thermocouple range> When the U, L, B, or S range is selected using the SHIFT key, the type of thermocouple is displayed.  
<Calibration mode> This mode displays the lower two digits of the measured or generated value.
- h. Displays the unit of the range selected.
- i. ON  
It lights up when the output is turned on in SOURCE mode (signal generation).
- j. RJ-ON  
It lights up when the reference junction compensation is being calculated in SOURCE mode (signal generation).
- k. JPT100  
It lights up when the JPT100 standard is selected in the RTD range (PT100 range). Refer to Section 5.3 "Generating Resistance or RTD Signal", 6.3 "Measuring Resistance or RTD Signal" and 7, "Other Features."

#### <2> Output value setting keys

Sets an output value for SOURCE mode (signal generation). The [▲]/[▼] keys are provided under each digit, whose value is increased or decreased in increments of 1. Carry of the digit is applied to increasing the value (pressing the [▲] key) when it is 9. Borrow of the digit is applied to decreasing the value (pressing the [▼] key) when it is 0.

#### <3> POWER key

Turns on/off the power supply. For more information, see Section 4, "Turning the Power On/Off."

#### <4> SHIFT key

Selects the type of thermocouple or the resistance temperature detector being selected by the range selection rotary switch (e.g., thermocouple type: S←→R).

#### <5> Range selection rotary switch

Selects a range for SOURCE mode (signal generation) or MEASURE mode (measurement).

Yokogawa Meters & Instruments Corporation

**International Sales Dept.**  
Tachihara Bld. No.2, 6-1-3, Sakaecho, Tachikawa-shi, Tokyo 190-8586 Japan  
Phone: 81-42-534-1413, Facsimile: 81-42-534-1426

**YOKOGAWA CORPORATION OF AMERICA (U.S.A.)**  
Phone: 1-800-888-6400 Facsimile: 1-770-254-0928

**YOKOGAWA EUROPE B. V. (THE NETHERLANDS)**  
Euroweg 2, 3825 HD, Amersfoort, THE NETHERLANDS  
Phone: 31-88-4641000 Facsimile: 31-88-4641111

**YOKOGAWA AMERICA DO SUL LTDA. (BRAZIL)**  
Phone: 55-11-5681-2400 Facsimile: 55-11-5681-4434

**YOKOGAWA ENGINEERING ASIA PTE. LTD. (SINGAPORE)**  
Phone: 65-6241-9933 Facsimile: 65-6241-2606

**YOKOGAWA MEASURING INSTRUMENTS KOREA CORPORATION (KOREA)**  
Phone: 82-2-551-0660 to -0664 Facsimile: 82-2-551-0665

**YOKOGAWA AUSTRALIA PTY. LTD. (AUSTRALIA)**  
Phone: 61-2-8870-1100 Facsimile: 61-2-8870-1111

**YOKOGAWA INDIA LTD. (INDIA)**  
Phone: 91-80-4158-6000 Facsimile: 91-80-2852-1441

**YOKOGAWA SHANGHAI TRADING CO., LTD. (CHINA)**  
Phone: 86-21-6239-6363 Facsimile: 86-21-6880-4987

**YOKOGAWA MIDDLE EAST B. S. C (C) (BAHRAIN)**  
Phone: 973-17-358100 Facsimile: 973-17-336100

**YOKOGAWA ELECTRIC CIS LTD. (RUSSIAN FEDERATION)**  
Phone: 7-495-737-7868 Facsimile: 7-495-737-7869

IM3E-2009.2

#### Notice regarding the Manual

- <1> The information contained in this User's Manual is subject to change without notice.
- <2> Every effort has been made to ensure that the information contained herein is accurate. However, should any concerns, errors, or omissions come to your attention, or if you have any comments, please contact us.

#### <6> MEASURE (measurement) / SOURCE (generation) selection switch

Selects MEASURE (measurement) or SOURCE (generation).

#### <7> Input/output terminals

Used for MEASURE (measurement) and SOURCE (generation) in each range.

#### <8> 3W input terminal

Used for MEASURE (measurement) in a three-wire connection configuration in the resistance or RTD range.

#### <9> Terminal adapter

Attached to the instrument's terminals when measuring a thermocouple signal or when lead wires are to be connected directly to the terminals.

#### <10> AC Adapter connection jack

Used to connect an AC adapter (optional).

#### <11> RJ sensor input connector

When using an external RJ sensor (optional), connect it to this connector.

#### <12> DIP switches

See Section 7, "Other Features."

#### <13> Battery holder

Contains four AA-size batteries. See Section 3, "Replacing Batteries."

#### <14> Lead cables for measurement or generation

Used to connect the instrument to the device under measurement/generation.

### 3. Replacing Batteries

When the mark is blinking on the display unit, the batteries are exhausted. Replace them according to the following procedure:

- <1> Check that the power is turned off (disconnect the lead cables).
- <2> Slide off the cover at the back of the instrument.
- <3> Replace all four batteries with new ones. Insert them according to the polarity directions shown inside the holder.
- <4> After replacing the batteries, return the cover to the original position.

#### Connecting the AC Power (optional)

##### Before connecting the AC power

Strictly observe the following warnings to avoid electrical shock or damage to the instrument.



- Do not use any AC adapter other than the dedicated AC adapter from Yokogawa.
- Before connecting the power cord, check that the supply voltage matches the rated voltage of the instrument.
- Before connecting the power cord, check that the instrument's power key is OFF.

#### Connection procedure:

- <1> Check that the [POWER] key of the instrument is off.
- <2> Connect the AC adapter (optional) to the instrument's AC adapter connection jack. (Note that unless the AC adapter is connected to the power outlet, the power cannot be turned on).

### 4. Turning the Power On/Off

#### Operating the POWER Key

When the instrument's power is off, pressing and holding the [POWER] key for more than 1 second causes the power to be turned on. Pressing the key again causes it to be turned off. When the power is turned on, the instrument starts a self-test and displays "CA12E." Then the features selected using the range selection rotary switch and the MEASURE/SOURCE selection switch start functioning.

- For battery-driven operations, disconnect the AC adapter from the instrument.

#### Automatic Power Off

In the factory setting, all indications start blinking if the instrument has not been operated for about 9.5 minutes. Then, if the instrument is not operated for another 30 seconds, it automatically turns off. To disable this automatic power off feature, see Section 7, "Other Features."

If you wish to keep the instrument turned on after the indications start blinking, press the [POWER] key (or any other key). This causes the blinking to return to normal lighting, without changing the previous settings.

### 5. SOURCE (generation)

#### 5.1 Connecting the Output Terminals

- <1> Insert the plugs of the supplied lead cables into the output terminals of the instrument.
- <2> Connect the clips on the other ends of the cables to the input terminals of the device under generation.

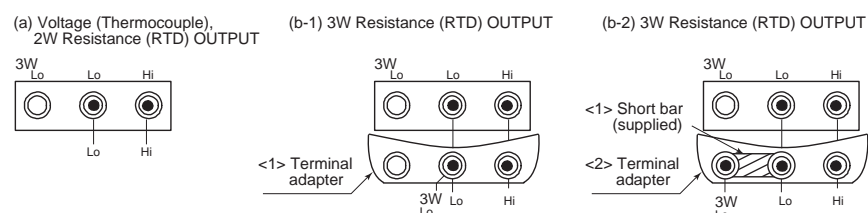

- When calibrating a resistance temperature detector or a resistance measurement unit in a three-wire connection configuration, the supplied terminal adapter can be used to achieve a three-wire connection configuration without shorting the Lo terminal (Fig. b-1). Lo and 3W-Lo terminals can be shorted (Fig. b-2). Otherwise connect as shown in Fig. a.

**CAUTION**

- Do not apply any voltage to the output terminals during signal generation. If voltage is applied by mistake, the internal circuit may be damaged.

**NOTE**

- As the instrument is calibrated without the voltage drop of the lead cables, error due to the resistance of the lead cables (approximately 0.1 Ω for go and return) must be considered for load current measurement.

### 5.2 Generating DC Voltage

The instrument generates voltage at a specified value through the output terminals.

**Normal setting:**

- <1> Switch the MEASURE/SOURCE selection switch to "SOURCE" (generation). This causes the display unit to show "SOURCE" and "ON."
- <2> Select the range to be generated using the range selection rotary switch. The display unit shows an initial value and unit for each range.
- <3> Press the [▲]/[▼] keys under each digit to set an output value.

### 5.3 Generating Resistance or RTD Signal

The output terminals of the instrument generate resistance with a value that corresponds to the specified resistance value or the RTD temperature.

**<Switching between PT100 and JPT100>**

Use the range selection rotary switch to select the PT100 (JPT100) range. When the PT100 range is selected, press the SHIFT key to switch to the JPT100 range ("JPT100" is displayed). Press the SHIFT key again to return to the PT100 range. For the ITS90 and IPTS68 range settings, see Subsection 7.2, "Selecting Thermocouple Standard."

**NOTE**

- The method of simulating resistance output is by generating voltage according to the excitation current [I] received from the device under calibration, due to the equation:  
 $R \text{ (required resistance)} = V \text{ (generated voltage)} / I \text{ (current received from device)}$   
The device to be calibrated must have the excitation current for resistance measurement.
- The standard range of resistance-measuring current that the CA12E must receive from the resistance-measuring device under calibration is between 0.5 mA and 2 mA. When the current is above 2 mA, accurate resistance generation is not possible. When it is below 0.5 mA, the margin of error increases. For more information, see Section 9, "Specifications."
- The generated resistance value is calibrated without taking the resistance value of the lead cables into consideration. Resistance value is increased by approximately 0.1 Ω at the lead cable ends.
- If capacitance between the terminals of the resistance-measuring device under calibration becomes 0.1 μF or more, the CA12E may not be able to generate the correct resistance value.

### 5.4 Generating a Thermocouple (TC) Signal

The instrument generates thermo-electromotive force from the output terminals, corresponding to the specified thermocouple (TC) temperature.

**<Selecting and switching thermocouple>**

Use the range selection rotary switch to select the type of thermocouple (TC) from J(U), T(L), N(B), and R(S).

Use the SHIFT key to switch among U, L, B, and S.

The selected type is shown in the Sub Seven Segment.

**<External RJ sensor and reference junction compensation>**

When a thermocouple (excluding B type) signal is generated and you directly calibrate a thermometer with a built-in reference junction compensation function without an external 0°C reference junction compensation means, use an RJ sensor (optional) as follows. (The built-in RJ sensor can also be used to carry out calibration (see Section 7, "Other Features").)

- <1> Connect the RJ sensor to the RJ sensor input connector of the instrument. Insert the sensor so that the tab at the bottom of the connector is locked in. To release the connector, gently press the locking tab downward to unlock the connector, then remove it.
- <2> When the sensor is connected, the instrument displays "RJ-ON" and outputs a thermo-electromotive force based on the temperature detected by the RJ sensor.

- The thermo-electromotive force is obtained by subtracting the value detected by the RJ sensor from the calculated thermo-electromotive force without the RJ sensor.
- Compensation of output voltage according to the temperature detected by the RJ sensor is achieved by a sampling approximately every 4 seconds. Thus, there is a maximum delay of 4 seconds between the connection of the connector and the start of compensation.
- For accurate compensation, an interval must lapse after connecting the RJ sensor to allow for temperature stabilization.

**NOTE**

- Be sure to remove the RJ sensor from the connector of the instrument when reference junction compensation is not necessary.

## 6. Measurement

**WARNING**

- When connecting the device under measurement, turn off the power of the device. Connecting/disconnecting the lead cables for measurement without turning off the power of the device under measurement may be extremely dangerous.
- Special care should be taken to avoid connecting a current circuit to the input terminals. Inadvertent connection may not only cause damage to the circuit or device under measurement and the instrument, but may also be dangerous to personnel.
- The maximum allowable voltage between all input/output terminals and ground is 42 V. Any voltage exceeding this level may not only damage the instrument, but also cause injury to personnel. Never attempt to apply such voltage.

**CAUTION**

- Do not apply any voltage to the input terminals that is above the measurement range. This may damage the instrument.

## 6.1 Connecting Procedure

- <1> When connecting a thermocouple or the lead wires, they must be attached to the terminal adapter supplied with the instrument.
- <2> For measurements of the voltage, the resistance, or RTD in a two-wire connection configuration, connect the supplied lead cables to the terminals of the instrument, or the lead wires to the terminal adapter (see following Figure "a"). For measurements of the resistance or RTD in a three-wire connection configuration, connect the lead wires to the terminal adapter, or to the terminals of the instrument (see following Figure "b").
  - Be sure to remove the short-bar (supplied) from the terminal adapter (supplied).
  - For measurements of the resistance or the RTD in a two-wire connection configuration, do not leave the lead wires connected to the 3W-Lo terminal.
- <3> Connect the clips on the other cable ends to the device under measurement.
  - For accurate measurement of the resistance or the RTD, make sure that the leading ends of the lead wires do not touch anything other than the device under measurement.

a. Connection of the input terminals for measuring voltage, a thermocouple signal, the resistance in a two-wire connection configuration, or an RTD signal in a two-wire connection configuration

b. Connection of the input terminals for measuring the resistance in a three-wire connection configuration and an RTD signal in a three-wire connection configuration

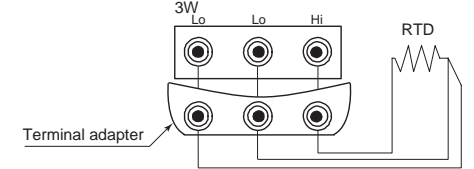
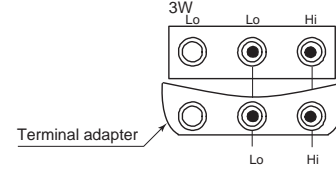

## 6.2 Measuring DC Voltage

- <1> Switch the MEASURE/SOURCE selection switch to MEASURE (measurement). MEASURE lights up on the display unit.
- <2> Select the range to be measured (100 mV) using the range selection rotary switch. The measured value is displayed.
  - If measured data is out of range or not measurable, the display unit shows "----."

## 6.3 Measuring Resistance or RTD Signal

- <1> Switch the MEASURE/SOURCE selection switch to MEASURE (measurement). MEASURE lights up on the display unit.
- <2> Select the range to be measured using the range selection rotary switch. The measured value is displayed.
  - If measured data is out of range or not measurable, the display unit shows "----."

**<Measuring RTD>**

Use the range selection rotary switch to select the PT100 (JPT100) range. When the PT100 range is selected, press the SHIFT key to switch to the JPT100 range ("JPT100" is displayed). Press the SHIFT key again to return to the PT100 range. For the ITS90 and IPTS68 range settings, see Subsection 7.2, "Selecting Thermocouple Standard."

## 6.4 Measuring Thermocouple

- <1> Switch the MEASURE/SOURCE selection switch to MEASURE (measurement). MEASURE lights up on the display unit.
- <2> Select the thermocouple (J(U), T(L), N(B), or R(S)) to be measured using the range selection rotary switch. Use the SHIFT key to switch among U, L, B, and S.
  - The display unit shows the results of the corresponding temperature on which the internal RJ sensor-measured temperature compensation was based.
  - If the input terminals are open, the display unit shows "-bo-" (burnout).
  - If the measurement data is out of range or not measurable, the display unit shows "----" (If the temperature in the operating environment of the instrument changes rapidly, wait until RJ compensation stabilizes and then use the instrument).

## 7. Other Features

The following features are available depending on the settings of the DIP switches above the battery holder, which can be accessed by removing the cover from the back of the instrument.



- 1: Reference junction compensation by the internal RJ sensor
- 2: Temperature
- 3: Setting of thermocouple standard (OFF: ITS90/ON: IPTS68)
- 4: Disable automatic power off

### 7.1 Reference Junction Compensation by the Internal RJ Sensor

When generating a thermocouple signal, setting DIP switch 1 to "ON" enables the instrument's internal RJ sensor to output a temperature compensated thermo-electromotive force.

### 7.2 Temperature

Check that the DIP switch 2 should be placed in the OFF position.

### 7.3 Selecting Thermocouple Standard

When selecting the range of the PT100 (JPT100), use DIP switch 3 to select the temperature scale standard.

OFF: ITS90

ON: IPTS68 ("68" appears in the Sub Seven Segment)

JPT100 is of the IPTS68 standard, so its temperature scale cannot be set using DIP switch 3 (For RTD generation and measurement, the SHIFT key can be used to switch between the PT100 and the JPT100).

### 7.4 Disabling Automatic Power Off

According to the factory setting of the instrument, it automatically turns itself off if not operated for about 10 minutes. By setting DIP switch 4 to "ON," this function can be disabled.

However, when the instrument is battery-driven, it is generally recommended that this switch be set to "OFF" in order to prevent the batteries from being exhausted.