**User's
Manual**

CW120/121
CLAMP-ON POWER METERS
Communication Functions

IM CW120C-E

Introduction

This user's manual is applicable to the CW120 (three-phase three-wire model) and CW121 (three-phase four-wire model) clamp-on power meters (hereinafter referred to as CW120/121) whose firmware version is Ver. 1.06 or later, and provides information necessary for using communication functions and creating communication programs.

- The CW120/121 clamp-on power meters use the following communication protocols:
 - 1) CW120/121-dedicated communication protocol
 - 2) Power monitor (PR201) communication protocol
 - 3) MODBUS communication protocol
 - 4) PC link communication protocol

The CW120/121 cannot communicate with a higher-level device that does not use any of the communication protocols above.

You are required to have background knowledge on the higher-level devices to be connected to in order to understand the communication specifications, communication hardware, language used for creating communication programs of higher-level devices, and so on.

Note:

- * PR201: Yokogawa panel-mounted power monitor
 - * Higher-level devices: PCs, PLCs (sequencers), graphic panels, and others.
-
- For details on the functions or how to operate the CW120/121, see the IMCW120-E user's manual, "CW120/121 Clamp-on Power Meters."

Notices

■ Regarding This User's Manual

- (1) This manual should be passed on to the end user. Keep this manual in a safe place.
- (2) Read this manual carefully to gain a thorough understanding of how to operate this product before you start using it.
- (3) This manual is intended to describe the functions of this product. Yokogawa (hereinafter simply referred to as Yokogawa) does not guarantee that these functions are suited to the particular purpose of the user.
- (4) Under absolutely no circumstance may the contents of this manual, in part or in whole, be transcribed or copied without permission.
- (5) The contents of this manual are subject to change without prior notice.
- (6) Every effort has been made to ensure accuracy in the preparation of this manual. Should any errors or omissions come to your attention however, please contact your nearest Yokogawa representative or our sales office.

■ Regarding Protection, Safety, and Prohibition Against Unauthorized Modification

- (1) In order to protect the product and the system controlled by it against damage and ensure its safe use, make certain that all of the instructions and precautions relating to safety contained in this document are strictly adhered to. Yokogawa does not guarantee safety if products are not handled according to these instructions.
- (2) The following safety symbols are used on the product and/or in this manual.

Danger! Handle with Care.

This symbol indicates that the operator must refer to an explanation in the instruction manual in order to avoid risk of injury or death of personnel or damage to the instrument.

Functional Grounding Terminal

This symbol indicates that the terminal must be connected to ground for good function prior to operating the equipment.

 **CAUTION**

Indicates a hazard that may result in an injury to the user and/or physical damage to the product or other equipment unless the described instruction is abided by.

 **NOTE**

Indicates information that is essential for handling the instrument or should be noted in order to familiarize yourself with the instrument's operating procedures and/or functions.

SEE ALSO

Indicates the reference location(s) for further information on the present topic.

Symbols used in figures:**[NOTE]**

Draws attention to information that is essential for understanding the operation and/or features of the product.

■ Description of Displays

- (1) Some of the representations of product displays shown in this manual may be exaggerated, simplified, or partially omitted for reasons of convenience when explaining them.
- (2) Figures and illustrations representing the controller's displays may differ from the real displays in regard to the position and/or indicated characters (upper-case or lower-case, for example), to the extent that they do not impair a correct understanding of the functions and the proper operation and monitoring of the system.

■ **Force Majeure**

- (1) Yokogawa does not make any warranties regarding the product except those mentioned in the WARRANTY that is provided separately.
- (2) Yokogawa assumes no liability to any party for any loss or damage, direct or indirect, caused by the use or any unpredictable defect of the product.
- (3) Be sure to use the spare parts approved by Yokogawa when replacing parts or consumables.
- (4) Modification of the product is strictly prohibited.
- (5) Reverse engineering such as the disassembly or decompilation of software is strictly prohibited.
- (6) No portion of the product supplied by Yokogawa may be transferred, exchanged, leased or sublet for use by any third party without the prior permission of Yokogawa.
- (6) Every effort has been made to ensure accuracy in the preparation of this manual. Should any errors or omissions come to your attention however, please contact your nearest Yokogawa representative or our sales office.

Contents

Introduction	i
Notices	ii
Chapter 1. Communications Overview	1-1
1.1 Overview	1-1
1.2 Interface Specifications	1-2
1.3 Setup of Communication	1-3
1.3.1 Setup Procedure of Communication	1-3
1.3.2 Wiring for Communication	1-3
1.3.3 Setting Communication Parameters	1-6
Chapter 2. Communication Dedicated to CW120/121	2-1
2.1 Overview	2-1
Chapter 3. Power Monitor (PR201) Communication	3-1
3.1 Overview	3-1
3.2 Communication Specifications	3-1
3.3 Commands and Responses	3-1
3.4 List of Commands	3-3
Chapter 4. MODBUS Communication	4-1
4.1 Overview	4-1
4.1.1 Configuration of Messages	4-2
4.2 Communication with Higher-level Device	4-2
4.2.1 List of Function Codes	4-3
4.3 Error Check	4-4
4.3.1 ASCII Mode	4-4
4.3.2 RTU Mode	4-4
4.4 Responses from Slaves	4-5
4.4.1 Responses to Normal Messages	4-5
4.4.2 Responses to Abnormal Messages	4-6
4.5 Commands	4-7
4.5.1 Function Code 03: Readout of D Registers	4-7
4.5.2 Function Code 06: Writing to a Single D Register	4-9
4.5.3 Function Code 08: Loop-back Test	4-9
4.5.4 Function Code 16: Writing to Multiple Data-retaining D Registers	4-10

Chapter 5. PC Link Communication	5-1
5.1 Overview	5-1
5.1.1 Configuration of Commands	5-1
5.1.2 Configuration of Response	5-2
5.2 Communication with Higher-level Device	5-3
5.3 Response Error Codes	5-4
5.4 List of Commands	5-5
5.4.1 BRD Reads I relays on a bit-by-bit basis.	5-6
5.4.2 BWR Writes data into I relays on a bit-by-bit basis.	5-7
5.4.3 BRR Reads I relays on a bit-by-bit basis in a random order.	5-8
5.4.4 BRW Writes data into I relays on a bit-by-bit basis in a random order.	5-9
5.4.5 BRS Specifies I relays to be monitored on a bit-by-bit basis.	5-10
5.4.6 BRM Monitors I relays on a bit-by-bit basis.	5-11
5.4.7 WRD Reads D registers and I relays on a word-by-word basis.	5-12
5.4.8 WWR Writes data into D registers and I relays on a word-by-word basis.	5-13
5.4.9 WRR Reads D registers and I relays on a word-by-word basis in random order.	5-14
5.4.10 WRW Writes data into D registers and I relays on a word-by-word basis in random order.	5-15
5.4.11 WRS Specifies the D registers and I relays to be monitored on a word-by-word basis.	5-16
5.4.12 WRM Monitors the D register and I relays on a word-by-word basis.	5-17
5.4.13 INF Reads the model, version, and revision information.	5-18
Chapter 6. Functions and Usage of D Registers and I Relays	6-1
6.1 Functions and Usage of D Registers	6-1
6.1.1 Power Monitor PR201 Common Register Map	6-2
6.1.2 CW120/121 Dedicated Register Map	6-5
6.2 Functions and Usage of I Relays	6-10

1. Communications Overview

1.1 Overview

The CW120/121 has either an RS-232 serial communication interface or RS-485 serial communication interface, through which data exchange can be performed with a device such as a personal computer, PLC (sequencer), or graphic panel.

Hereafter, PCs, PLCs (sequencers), and graphic panels are referred to as “higher-level devices.”

At the time of purchase, specify the suffix code for either RS-232 communication or RS-485 communication.

Model	Suffix Code	Description
CW120		(Three-phase three-wire)
CW121		(Three-phase four-wire)
	-D, F, R, or S	AC power cord
	-1	RS-232 communication interface
	-2	RS-485 communication interface

Table 1.1 Communication Protocols

Communication Protocol		Descriptions
CW120/121-dedicated communication		CW120/121-dedicated communication standard
Power Monitor communication		Communication standard used for power monitor
PC link communication with sum check		With error check
PC link communication without sum check		Without error check
MODBUS communication ASCII mode		Communication using ASCII data
MODBUS communication RTU mode		Communication using Binary data



NOTE

- **Confirm the Model and Specifications.**
- **Attempting to save data to a PC card while performing heavy-load communication may result in some data being lost. In such a case, decrease the baud rate. If such a loss of data still persists, disable (off) the function for saving data to a PC card. Then, save data, which you acquired through communication, on the upper-level device side instead.**

1.2 Interface Specifications

- Specifications common to RS-232 and RS-485 communication
 - Synchronization: Asynchronous
 - Station number: 001 to 999
 - Baud rate: 1200, 2400, 4800, 9600, 19200, 38400 bps
 - Data bits: 7 or 8 bits
 - Parity: Odd, even, or none
 - Start bits: Fixed to 1 bit
 - Stop bits: 1 or 2 bits
- Specifications specific to RS-232 communication
 - Electromechanical specifications: Compliant with EIA RS-232
 - Topology: Point to point
 - Communication method: Full duplex
 - Connector: Miniature DIN, 8 pins
 - Hardware handshake: Whether to set CA (RTS) and CB (CTS) to true or use them as control signals can be chosen.
 - Software handshake: Transmission/reception control by X-on and X-off signals is possible.
 - X-on (ASCII 11H)
 - X-off (ASCII 13H)
 - Error detection: Set by communication protocol
 - Reception buffer length: 1024 bytes
- Specifications specific to RS-485 communication
 - Electromechanical specifications: Compliant with EIA RS-485
 - Topology: Multidrop
 - Communication method: Half duplex
 - Connector: 4 screw terminals (M3)
 - Hardware handshake: Not available
 - Software handshake: Not available
 - Error detection: Set by communication protocol
 - Reception buffer length: 1024 bytes
 - Maximum transmission distance: 1.2 km (when using shielded cable containing 2 twisted pairs of AWG 24 conductors)
 - Terminating resistor: Approx. 120 Ω built-in

1.3 Setup of Communication

This chapter describes the procedure to set up the communication functions and also refers to some notes on wiring and communication parameters.

1.3.1 Setup Procedure of Communication

Set up the communication functions of the CW120/121 as follows:

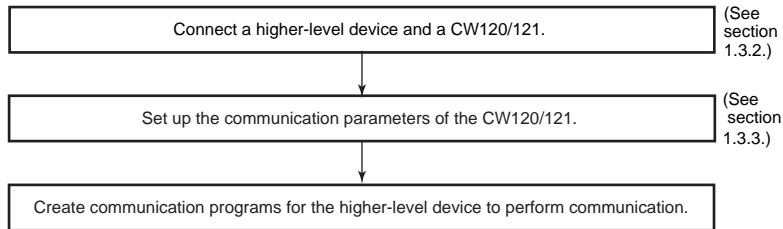

* Create communication programs referring to the documentation of each higher-level device.

* In this manual, higher-level devices generically denotes PCs, PLCs (sequencers), and graphic panels.

1.3.2 Wiring for Communication

Connect the CW120/121 controller and the higher-level device for communication. The wiring procedures and precautionary notes are as follows.

CAUTION

To avoid an electrical shock, be sure to turn off the power supply source to the equipment involved before you start wiring.
Before you start wiring, read the user's manual of each device.

● **Wiring for RS-485 Communication**

(1) Wiring to a Personal Computer

Since general personal computers cannot directly be connected to the RS-485 interface, wiring must be provided via an RS-232/RS-485 converter. The following figures show the wiring for 2-wire connection.

● **2-wire connection**

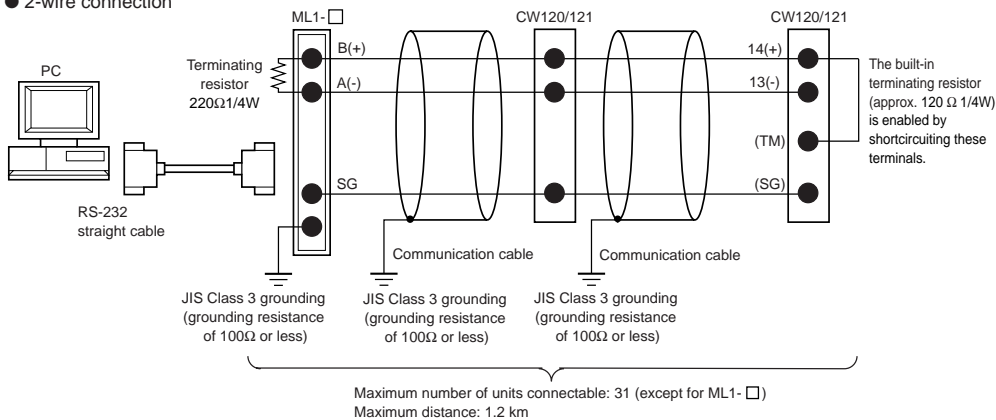

[NOTE] ML1-□ is the converter of Yokogawa M&C Corporation. You can also use other RS-232/RS-485 converters. Before you use another converter, check its electrical specifications.

⚠ CAUTION

Do not share the grounding wire with another controller. Doing so may result in a failure of the controller.

Use crimp terminals at the cable ends.

(2) Wiring to a PLC (Sequencer) or Graphic Panel

Since general PLCs (sequencers) and graphic panels have an RS-485 interface, they can be directly connected to a CW120/121. If your PLC (sequencer) or graphic panel has an RS-232 interface, see subsection (1).

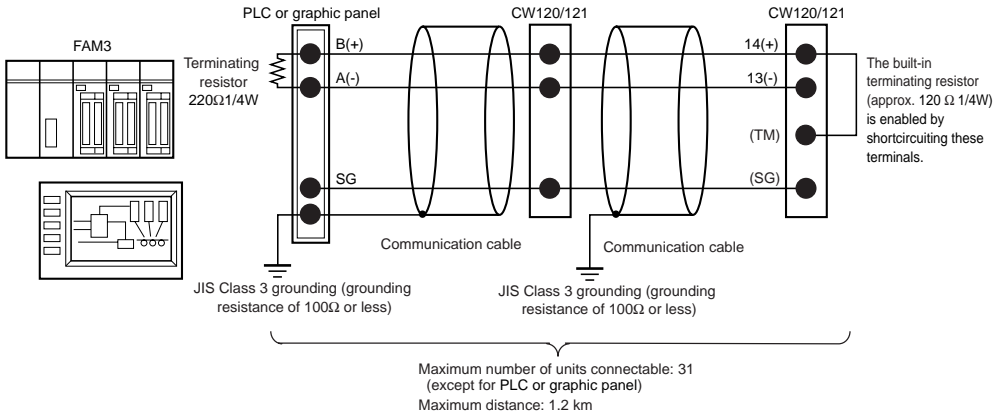

[NOTE] In the case of MELSEC (Mitsubishi Electric Corporation’s sequencer), “B” is for (-), and “A” is for (+). In the case of Graphic panel (Digital Corporation’s), RS232/RS485 converter is needed.

⚠ CAUTION

Do not share the grounding wire with another controller. Doing so may result in a failure of the controller.

Use crimp terminals at the cable ends.

● Wiring for RS-232 Communication

Wire the CW120/121 to a general personal computer as shown below.

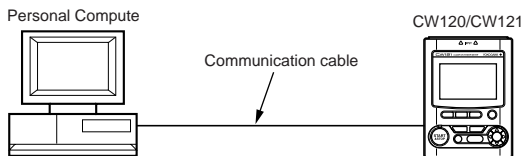

Note: Use the following communication cable.

Cable	Connectors	Part number
RS-232 communication cable for PC	9 pins	91011
	25 pins	91009

1.3.3 Setting Communication Parameters

This section describes the communication parameters and setting ranges necessary to use the communication functions.

(1) Setting Communication Protocols

Follow the procedure below to set the communication protocol supported by the higher-level device.

<Procedure>

- 1) When the measurement screen of the CW120/121 is displayed, press the **MEAS/SET** key to call the setting item selection screen.
- 2) Press either the Δ key or ∇ key until "Proto." is displayed in the upper part of the LCD.
- 3) Press the **ENTER** key and verify that the lower row on the LCD flashes.
- 4) Press either the Δ key or ∇ key to select the appropriate communication protocol as shown in the figure below.
- 5) Press the **ENTER** key to confirm the selection and return to the setting item selection screen. Press the **ESC** key to cancel a selection and return to the setting item selection screen.
- 6) Press the **MEAS/SET** key to return to the measurement screen.

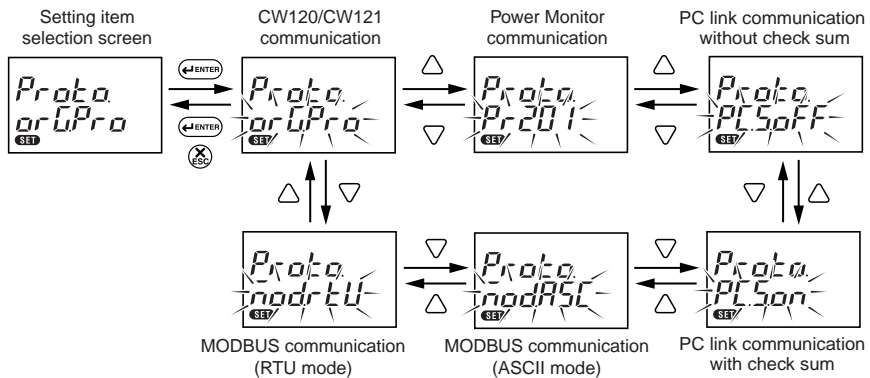

(2) Setting Station Number

Follow the procedure below to set the device number (station number) of the CW120/121 within the device number limits (Table 1.2) specific to each communication protocol.

Table 1.2 Communication protocols and device number limits

Communication protocol	Device number limits
CW120/121	1 to 999
Power monitor (PR201) communication	1 to 31
PC link communication without checksum	1 to 99
PC link communication with checksum	1 to 99
MODBUS communication (ASCII mode)	1 to 247
MODBUS communication (RTU mode)	1 to 247

<Procedure>

- 1) When the measurement screen of the CW120/121 is displayed, press the **MEAS/SET** key to call the setting item selection screen.
- 2) Press either the Δ key or ∇ key until the "NO." mark is displayed in the lower part of the LCD and the current setting for the device number is displayed in the upper row.
- 3) Press the **ENTER** key and verify that the least significant digit in the upper row on the LCD flashes.
- 4) Press either the \triangleleft key or \triangleright key to select a digit and change its value by pressing either the Δ key or ∇ key.
- 5) When you have finished setting the number, press the **ENTER** key to confirm the setting and return to the setting item selection screen. Press the **ESC** key to cancel a setting and return to the setting item selection screen.
- 6) Press the **MEAS/SET** key to return to the measurement screen.

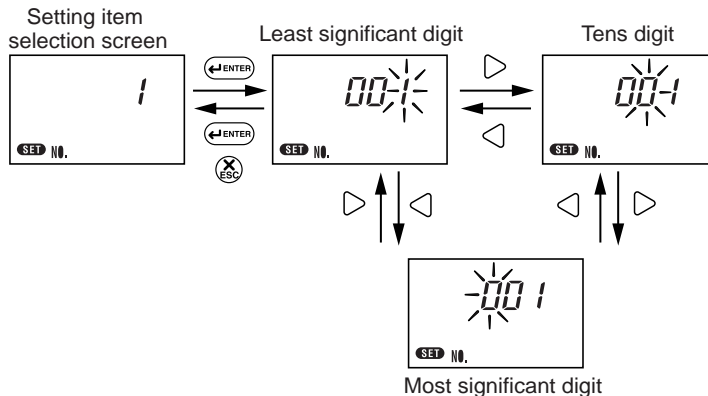

[NOTE] When connecting more than one device using RS-485 communication, be sure to use a unique device number for each device.

(3) Setting Communication Interface Parameters

Follow the procedure below to set the communication interface parameters. Set the same communication interface parameters for the CW120/121 as those set for the higher-level device.

<Procedure>

- 1) When the measurement screen of the CW120/121 is displayed, press the **MEAS/SET** key to call the setting item selection screen.
- 2) Press either the Δ key or ∇ key until the "COM" mark is displayed in the lower part of the LCD, the current settings for the baud rate is displayed on the top row and the current settings for data length, parity, and stop bits are displayed in the lower row.
- 3) Press the **ENTER** key and verify that the baud rate in the upper row on the LCD flashes.
- 4) Press either the Δ key or ∇ key to select the baud rate.
- 5) Press the \triangleright key and verify that the rightmost number for the data length flashes.
- 6) Press either the Δ key or ∇ key to select the data length.
- 7) Press the \triangleright key and verify that the character in the middle for the parity flashes.
- 8) Press either the Δ key or ∇ key to select the parity.
- 9) Press the \triangleright key and verify that the number for the stop bits flashes.
- 10) Press either the Δ key or ∇ key to select the stop bits.
- 11) When you have finished making all the settings, press the **ENTER** key to confirm them and return to the setting item selection screen. Press the **ESC** key to cancel the settings and return to the setting item selection screen.
- 12) Press the **MEAS/SET** key to return to the measurement screen.

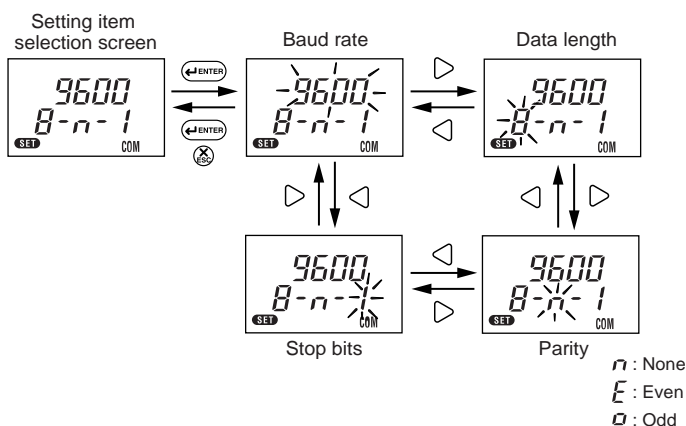

SEE ALSO

Chapter 7 of the IM CW120-E user's manual for details on how to make settings.

2. Communication Dedicated to CW120/121

2.1 Overview

Communication dedicated to CW120/121 allows a variety of measurement values to be read by a higher-level device and the CW120/121 to be configured from a higher-level device. The communication protocol used is different than that used during RS-232 or RS-485 communication. For details, see the appendix of IMCW120-E, "Communication Commands."

3. Power Monitor (PR201) Communication

3.1 Overview

Using the command/response method, you can read a variety of measured values onto your personal computer. Readout can be achieved in two ways: reading measured values one by one or reading the values at one time (those of measurement data items assigned in the selected parameter).

3.2 Communication Specifications

Station number: 1 to 31

Communication error handling:

The CW120/121 discards a received command and returns no response if the command is invalid (ignores electrical noise and faulty commands). Any time-out process therefore should be run at the higher-level personal computer. Set the time-out option to a value no smaller than one second. The CW120/121 returns an error response if the parameter or data is erroneous.

3.3 Commands and Responses

Command elements:

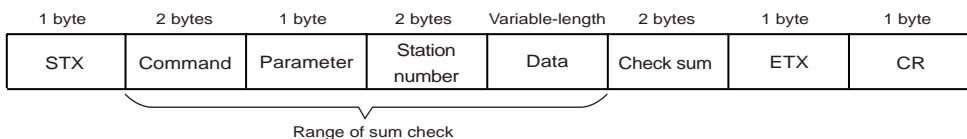

STX: Start of Text (hexadecimal: 02)

Command: 2-byte ASCII code (DG or DP)

Parameter: 1-byte ASCII code (0 to X)

Station number: 2-byte ASCII code (01 to 1F)

Data: Not provided at the time of data readout; provided as variable-length ASCII code at the time of setpoint change (byte size depends on the type of parameter)

Check sum: 2-byte ASCII code (00 to FF) representing a value obtained by summing the data within the range of sum check in a hexadecimal way and then converting the least significant two digits to an ASCII code

ETX: End of Text (hexadecimal: 03)

CR: Carriage Return (hexadecimal: 0D)

Response elements:

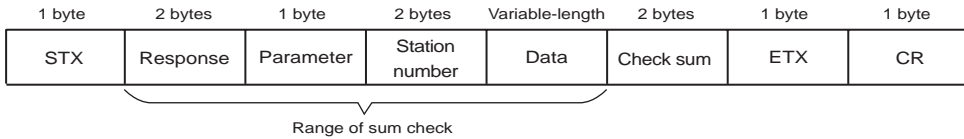

- STX: Start of Text (hexadecimal: 02)
- Response: 2-byte ASCII code (DG or DP)
- Parameter: 1-byte ASCII code (0 to Z)
- Station number: 2-byte ASCII code (01 to 1F)
- Data: Variable-length ASCII code (byte size depends on the type of parameter)
- Check sum: 2-byte ASCII code (00 to FF) representing a value obtained by summing the data within the range of sum check in a hexadecimal way and then converting the least significant two digits to an ASCII code
- ETX: End of Text (hexadecimal: 03)
- CR: Carriage Return (hexadecimal: 0D)

3.4 List of Commands

Table 3.1 Command:DG (1/3)

Parameter	Descriptions	Power monitor adaptable models	Power monitor response data format	Power monitor response data range	Response data size	CW120/121 response data
0	Measured value read-out in block	No optional measuring	Data of parameters 1 to 5		40 bytes	
		Power factor measuring	Data of parameters 1 to 5 and 6 (power factor measuring)		46 bytes	Transfer of data of parameters 1 to 6
		Current 2 measuring	Data of parameters 1 to 5 and 6 (current 2 measuring)		48 bytes	
1	Active electric energy read-out		□□□□□	00000 to 99999 [kWh]	5 bytes	00000 to 99999 [kWh]
2	Optional active electric energy read-out	Preceding value	□□□□□	00000 to 99999 [Wh]	10 bytes	00000 [kWh]
		Present value	□□□□□	00000 to 99999 [Wh]	10 bytes	00000 [Wh]
3	Instantaneous active power value		±□. □□□E+O	±0.001E+2 to ±9.999E+6 [W]	9 bytes	±0.000E+0 to ±9.999E+9 [W]
						"----" 0 "Or" Voltage range: 150 V, 300 V Rated power range × 1.69 Voltage range: 450 V Rated power range: × 1.43
4	Voltage 1 instantaneous value		±□. □□□E+O	±0.001E+2 to ±9.999E+6 [V]	8 bytes	±0.000E+0 to ±9.999E+9 [V]
						"----" 0 "Or" Voltage range: 150 V, 300 V Rated voltage range × 1.3 Voltage range: 450 V Rated voltage range: × 1.1
5	Current 1 instantaneous value		±□. □□□E+O	±0.001E+2 to ±9.999E+6 [A]	8 bytes	±0.000E+0 to ±9.999E+9 [A]
						"----" 0 "Or" Rated current range: × 1.3
6	Optional instantaneous value	No optional measuring	No data		0 byte	
		Power factor measuring	△□. □□□	D0. 500 to 1.000 to G0. 500	6 bytes	D0.500 to 1.000 to G0.500 "----" 0
		Current 2 measuring	□. □□□E+O	0.001E+0 to ±9.999E+6 [A]	8 bytes	
7	Optional		No data		0 byte	No data
8	integration start		No data		0 byte	No data
9	Optional integration stop		No data		0 byte	No data
A	Measured and maximum/minimum values read-out in block	No optional measuring	Data of parameters 1 to 5 and B to D		64 bytes	
		Power factor measuring	Data of parameters 1 to 6 and B to D		70 bytes	Data of parameters 1 to 6 and B to D transferred
		Current 2 measuring	Data of parameters 1 to 6 and B to D		72 bytes	

"Or": The input value is over the range.

"----": Measurement not possible because input value is out of measurement range.

Table 3.1 Command:DG (2/3)

Parameter	Descriptions	Power monitor adaptable models	Power monitor response data format	Power monitor response data range	Response data size	CW120/121 response data
B	Voltage 1 maximum value read-out		□. □□□E+O	±0.001E+2 to ±9.999E+6 [V]	8 bytes	0.000E+0 [V]
C	Voltage 1 minimum value read-out		□. □□□E+O	±0.001E+2 to ±9.999E+6 [V]	8 bytes	0.000E+0 [V]
D	Current 1 maximum value read-out		□. □□□E+O	±0.001E+0 to ±9.999E+6 [A]	8 bytes	0.000E+0 [V]
E	Current 2 maximum value read-out	No current 2 measuring	No data		0 byte	No data
		Current 2 measuring	□. □□□E+O		8 bytes	
F	Measured values read-out in block	No optional measuring	Data of parameters G, 2, 3, 4, H, J, 5, K, and L		75 bytes	
		Power factor measuring	Data of parameters G, 2, 3, 4, H, J, 5, K, and L, and 6 (power factor measuring)		81 bytes	Data of parameters G, 2, 3, 4, H, J, 5, K, and L, and 6 (power factor measuring) transferred
G	Active electric energy read-out		□□□□□E+O	00000E+3 to 99999E+6 [Wh]	8 bytes	00000E+3 to 9999E+6 [Wh]
H	Voltage 2 instantaneous value		□. □□□E+O	0.001E+2 to 9.999E+6 [V]	8 bytes	0.000E+0 to 9.999E+9 [V]
						"----" 0
I						
J	Voltage 3 instantaneous value		□. □□□E+O	0.001E+2 to 9.999E+6 [V]	8 bytes	0.000E+0 to 9.999E+9 [V]
						"---" 0
K	Current 2 instantaneous value		□. □□□E+O	0.001E+0 to 9.999E+6 [A]	8 bytes	0.000E+0 to 9.999E+9 [A]
						"---" 0
L	Current 3 instantaneous value		□. □□□E+O		8 bytes	0.000E+0 to 9.999E+9 [A]
						"---" 0
M	Measured and maximum/minimum values read-out in block	No optional measuring	Data of parameters G, 2, 3, 4, H, J, 5, K, L, and B, C, D, and N to T		123 bytes	
		Power factor measuring	Data of parameters G, 2, 3, 4, H, J, 5, K, and L, and 6 (power factor measuring), and B, C, D, and N to T		129 bytes	Data of parameters G, 2, 3, 4, H, J, 5, K, L, and 6 (power factor measuring), and B, C, D, and N to T

Table 3.1 Command:DG (3/3)

Parameter	Descriptions	Power monitor adaptable models	Power monitor response data format	Power monitor response data range	Response data size	CW120/121 response data
N	Voltage 2 maximum value read-out		□. □□□E+O	0.001E+2 to 9.999E+6 [V]	8 bytes	0.000E+0 [V]
O			□. □□□E+O		8 bytes	
P	Voltage 3 maximum value read-out		□. □□□E+O	0.001E+2 to 9.999E+6 [V]	8 bytes	0.000E+0 [V]
Q	Voltage 2 minimum value read-out		□. □□□E+O	0.001E+2 to 9.999E+6 [V]	8 bytes	0.000E+0 [V]
R	Voltage 3 minimum value read-out		□. □□□E+O	0.001E+2 to 9.999E+6 [V]	8 bytes	0.000E+0 [V]
S	Current 2 maximum value read-out		□. □□□E+O	0.001E+2 to 9.999E+6 [A]	8 bytes	0.000E+0 [A]
T	Current 3 maximum value read-out		□. □□□E+O	0.001E+2 to 9.999E+6 [A]	8 bytes	0.000E+0 [A]
U						
V						
W						
X	Model and suffix code read-out		PR201-□□□□□-△		14 bytes	Single-phase two-wire: PR201-11011-20 Single-phase three-wire: PR201-21011-20 Three-phase three-wire: PR201-31011-20 Three-phase four-wire: PR201-41011-20 Single-phase two-wire×2 PR201-11011-20 Single-phase two-wire×3 PR201-11011-20
Y						
Z	Error response		□□		2 bytes	00: Not error 80: Check sum error

"Or": The input value is over the range.

"----": Measurement not possible because input value is out of measurement range.

Table 3.2 Command:DP

Parameters	Descriptions	Power monitor adaptable models	Power monitor command data format	Power monitor command data range	Command data size	CW120/121 response data
0	Set value read-out		No data (response *1)		0 byte	VT ratio, CT ratio, Integrated low-cut power (value: 0)
1						
2						
3						
4	VT ratio setting		□□□□□	00001 to 32000	5 bytes	00001 to 10000 During setup, resets electric energy read-out and elapsed time. If integration is in progress, stops integration and resets. Then resumes integration.
5	CT ratio setting		□□□□□	00.05 to 32000	5 bytes	00001 to 10000 During setup, resets electric energy read-out and elapsed time. If integration is in progress, stops integration and resets. Then resumes integration.
6						
7						
8						
9						
A	Remote reset		No data		0 byte	No processing carried out
B	Integrated low-cut power		□□. □	00.1 to 99.9	4 byte	No processing carried out
C	Integrated pulse unit		□. □□□E-O	6.667E-6 to 1.000E-1	8 bytes	No processing carried out
D	ON pulse width of integrated pulse		□□□□	0010 to 1270	4 byte	No processing carried out
E	Input scaling "L" level setting for analog output		△□□□□ (Δ:+or-)	-4800 to +4800	5 bytes	No processing carried out
F	Input scaling "H" level setting for analog output		△□□□□ (Δ:+or-)	-4800 to +4800	5 bytes	No processing carried out
G	Electric energy reset		No data (buffer data is reset, too)		0 byte	Resets electric energy read-out and elapsed time. If integration is in progress, stops integration and resets. Then resumes integration.

*1: The response for set value read-out command is as follows:
VT ratio, CT ratio, and integrated low-cut power: 16 bytes

4. MODBUS Communication

4.1 Overview

A MODBUS communication protocol is one of the protocols used to communicate with devices such as PCs, PLCs (sequencers), and graphic panels. Via this communication protocol, these devices can exchange data with CW120/121 by reading/writing the internal registers (D registers) of a CW120/121.

Hereafter, PCs, PLCs (sequencers), and graphic panels are referred to as "higher-level devices."

SEE ALSO

As to configuration of inner registers, refer to "Function and usage of D register and I relay" (Chapter 6).

For the MODBUS communication of the CW120/121, two transmission modes are supported: ASCII mode (ASCII system) and RTU mode (binary system).

Table 4.1 ASCII and RTU Modes

Item	ASCII mode	RTU mode
Number of data bits	7 bits (ASCII), 8 bits (ASCII)	8 bits (binary)
Message start mark	: (colon)	Unnecessary
Message end mark	CR + LF	Unnecessary
Message length (Note 1)	2N + 1	N
Data time intervals	1 second or less	24-bit time or less (Note 2)
Error detection	Longitudinal redundancy check: LRC	Cyclic redundancy check: CRC-16

Note 1: When the message length in the RTU mode is assumed to be N.

Note 2: When the communication rate is 9600 bps, 1, 9600 · 24 sec. or less.

The next section will discuss the configuration of messages.

4.1.1 Configuration of Messages

Messages sent from a higher-level device to a CW120/121 consist of the following elements.

Mode \ Element	Start of Message Mark	Address Number (ADR)	Function Code	Data	Error Check	End of Message Mark
Number of bytes in ASCII mode	1	1	1	4n	2	2
Number of bytes in RTU mode	None	2	2	2n	2	None
	(1)	(2)	(3)	(4)	(5)	(6)

(1) Start of Message Mark

This mark indicates the start of a message. Note that only ASCII mode requires a colon.

(2) Address Number (1 to 247)

An address number is used by a higher-level device to identify which CW120/121 to communicate with. (ID number of CW120/ CW121)

(3) Function Code (See subsection 4.2.1, “List of Function Codes”)

The function code specifies a command (function code) from the higher-level device.

(4) Data

This element specifies D register numbers, the number of D registers, parameter values, and so on in accordance with the function code.

(5) Error Check

In ASCII mode carried out by the longitudinal redundancy check (LRC) system.

In RTU mode carried out by the cyclic redundancy check (CRC-16) system.

(6) End of Message Mark

This mark indicates the end of a message.

Note that only ASCII mode requires CR and LF.

4.2 Communication with Higher-level Device

When you use a commercially available SCADA or the like or a user-created communication program, you must be careful when specifying D register numbers contained in messages because in both cases, you cannot use the original D register numbers as they are.

● **To specify D registers**

(1) When using a commercially available SCADA or the like, specify D register numbers by changing them into reference numbers. To change them into a reference number, replace the D register number's leading character "D" with "4". (When using a DDE server or others, specify these reference numbers.)

(2) In a user-created communication program, specify a D register using the hexadecimal number of the value obtained by subtracting "40001" from the D register's reference number. (Specify this hexadecimal number.)

Example: To specify "D0101"

- For a message using commercially available SCADA or the like, specify reference number "40101."
- For a message in a user-created communication program, specify "0064", the hexadecimal number of "0100", which is obtained by subtracting 40001 from the reference number.



NOTE

In RTU mode, there may be a case when communication cannot be carried out with an upper-level device that detects frame delimiters at high speed. In such a case, decrease the baud rate.

4.2.1 List of Function Codes

Function codes are command words used by the higher-level device to obtain the D register information of CW120/121.

Table 4.2 Function Codes

Code	Function	Description
03	Reads data from multiple D registers.	Capable of reading data from a maximum of 32 successive registers from D0001 to D0576.
06		Capable of writing data to one register from D0001 to D0576.
08	Writes data into D register.	Capable of checking signal transmission.
16	Performs loop back test. Writes data into multiple D registers.	Capable of writing data into a maximum of 32 successive registers from D0001 to D0576.

- The write function codes will not write into read-only or disabled D registers.

4.3 Error Check

MODBUS communication has two modes: ASCII mode which is ASCII-text communication and RTU mode which is binary communication. These two modes use different error check methods.

4.3.1 ASCII Mode

In ASCII mode, an error check is run using the LRC method, i.e., logical redundancy check. This mode calculates the LRC value from the same data as that of the RTU mode. That is, all blocks of a message, from the slave address to the last data item, except the colon (:), carriage return (CR) and line feed (LF), are converted one byte hexadecimal data and summed on a byte-by-byte basis. A two's complement taken from least significant two bytes of the value thus obtained equals the LRC value. At this point, ignore any carry into the most significant digit occurring during the summing.

Example: Calculating the LRC value when the message is

[:303530333030363430303032][LRC][CR][LF]

- [1] Change the underlined ASCII data to one-byte hex data.
→05, 03, 00, 64, 00, 02
- [2] Sum up this one-byte hex data on a byte-by-byte basis.
→05 + 03 + 00 + 64 + 00 + 02 = 6E
- [3] Take the two's complement of the least significant one byte of the data thus summed up.
→92

4.3.2 RTU Mode

In RTU mode, an error check is run using the CRC-16 method, i.e., cyclic redundancy check. In this method, all blocks of a message, from the slave address to the last data item, are concatenated in series and the value thus obtained is divided by a predetermined 17-bit binary number. The resulting 16-bit remainder then equals the CRC-16 value.

Note that data subjected to computation is only the value given by the 8-bit block of the message and does not include the start bit, stop bit, and parity bit.

4.4 Responses from Slaves

A CW120/121 receives a command message from the higher-level device. If the received command message is found to be normal and directed at the slave address of the CW120/121 itself, the CW120/121 concludes the content of the message to be normal. Thus, the CW120/121 enters the phase of executing message processing, deciphers the content of the command message, and processes with the message.

The CW120/121 does not execute message processing, however, if the received command message is found to be abnormal. In that case, the CW120/121 either ignores the received message or creates a response message telling the received message is erroneous.

After receiving a normal command message and executing a given process, the CW120/121 creates and sends a response message to which error check data appropriate for the command function code of the higher-level device is added.

4.4.1 Responses to Normal Messages

For a loop back function or a function for writing to a single register, the CW120/121 returns the received command message as a response message.

For a function for writing to multiple registers, the CW120/121 returns part of the received command message as the response message.

For a readout function, the CW120/121 adds the read data to the ends of the address number and function code of the received command message, and returns the message as the response message.

4.4.2 Responses to Abnormal Messages

If there is any failure other than transmission errors, the CW120/CW121 returns the following response message without executing any process:

Address number
Function code + 80H
Error code
Error check data

The following table summarizes details on the error codes.

Error code	Description
01	Function code error (nonexistent error code)
02	Abnormal register number
03	Abnormal number of registers

The CW120/121 does not regard it as an error even if there is any unused register among those with consecutive register numbers specified by a read-out function; rather, the CW120/121 returns a value of 0 in this case.

The CW120/121 returns the error code 02 if the first of specified consecutive addresses is made to fall outside the given range by the number of registers specified, even though it was initially within the range.

4.5 Commands

4.5.1 Function Code 03: Readout of D Registers

In the example shown here, the function reads four consecutive registers starting from the register D0043 of the slave with the slave address 17. Take special note of the fact that the Starting D Register Number field is set to "42".

Table 4.3 Message Sent from Master

Element	Contents	HEX	Example for ASCII mode (Reference only)		Example for RTU Mode	
Start-of-message mark			3Ah (: colon)		(24-bit time)	
Address	17	11	31h		0001 0001	
			31h			
03 (=function code)	03	03	30h		0000 0011	
			33h			
Starting D register number (higher-order)	42	00	30h		0000 0000	
			30h			
Starting D register number (lower-order)		2A	32h		0010 1010	
			41h			
Number of D register (higher-order)	4 registers	00	30h		0000 0000	
			30h			
Number of D register (lower-order)		04	30h		0000 0100	
			34h			
Error check data			42h	=BEh	0110 0111	=6751h
			45h		0101 0001	
End-of-message mark			0Dh(=[CR])		None	
			0Ah(=[LF])			

Table 4.4 Message Sent from Slave

Element		Contents	HEX	Example for ASCII Mode (Reference only)	Example for RTU Mode (Reference only)
Start-of-message mark				3Ah (: colon)	(24-bit time)
Address		17	11	31h 31h	0001 0001
03 (= function code)		03	03	30h 33h	0000 0011
Byte count		8 bytes	08	30h 38h	0000 1000
Byte count for D register status (= number of registers32)	Higher -order	3F80	3F	33h 46h	0011 1111
	Lower -order			38h 30h	1000 0000
	Higher -order	0000	00	30h 30h	0000 0000
	Lower -order			30h 30h	0000 0000
	Higher -order	3F80	3F	33h 46h	0011 1111
	Lower -order			38h 30h	1000 0000
	Higher -order	0000	00	30h 30h	0000 0000
	Lower -order			30h 30h	0000 0000
Error check data				36h 36h	=66h 0000 1110 0111 0111
End-of-message mark				0Dh (= [CR]) 0Ah (= [LF])	None

* The D register numbers (addresses) are specified using relative addresses.
 * The maximum number of D registers that are read is 32.

4.5.2 Function Code 06: Writing to a Single D Register

Table 4.5 Message Sent from Master

Start-of-message mark
Address
06 (= function code)
D register number (higher-order)
D register number (lower-order)
Data to write (higher-order)
Data to write (lower-order)
Error check data
End-of-message mark

- * Data to write: Optional.
- * Specify D register numbers (addresses) using relative addresses.

Response from Slave

The slave returns the received command message as a response message.

4.5.3 Function Code 08: Loop-back Test

A loop-back test is used to check signal transmission.

Table 4.6 Message Sent from Higher-level Device

Start-of-message mark
Address
08 (= function code)
Diagnostic code (higher-order) fixed to 00
Diagnostic code (lower-order) fixed to 00
Data (higher-order)
Data (lower-order)
Error check data
End-of-message mark

Table 4.7 Diagnostic Codes

Diagnostic Code	Meaning	Data
00 00	Command message return	Arbitrary

Table 4.8 Message Sent from CW120/121

Start-of-message mark
Address
08 (= function code)
Diagnostic code (higher-order) fixed to 00
Diagnostic code (lower-order) fixed to 00
Data (higher-order)
Data (lower-order)
Error check data
End-of-message mark

Data: Varies depending on the diagnostic code sent from higher-level device.

4.5.4 Function Code 16: Writing to Multiple Data-retaining D Registers

This function enables you to change the states of D registers with consecutive addresses.

Table 4.9 Message Sent from Higher-level Device

Start-of-message mark
Address
10 (= function code)
Starting D register number (higher-order)
Starting D register number (lower-order)
Number of registers (higher-order)
Number of registers (lower-order)
Byte count
Data (higher-order)
Data (lower-order)
....
Error check data
End-of-message mark

Table 4.10 Message Sent from CW120/121

Start-of-message mark
Address
10 (=function code)
Starting D register number (higher-order)
Starting D register number (lower-order)
Number of registers (higher-order)
Number of registers (lower-order)
Error check data
End-of-message mark

* The maximum number of D registers to which data are written is 32.

5. PC Link Communication

5.1 Overview

PC link communication protocol is one of the protocols used to communicate with devices such as PCs, PLCs (sequencers), and graphic panels. Via this communication protocol, these devices can exchange data with a CW120/121 by reading/writing the controller's internal registers (D registers and I relays).

Hereafter, PCs, PLCs (sequencers), and graphic panels shall be referred to as "higher-level devices."

SEE ALSO

As to configuration of inner registers, refer to "Function and usage of D register and I relay" (Chapter 6).

The next section will discuss the configuration of commands and responses.

5.1.1 Configuration of Commands

Commands sent from a higher-level device to a CW120/121 consist of the following elements.

Number of bytes	1	2	2	1	3	Variable length	2	1	1
Element	STX	Address number (Station number)	CPU number 01	Time to wait for response 0	Command	Data corresponding to command	Check sum	ETX	CR
	(1)	(2)	(3)	(4)	(5)	(6)	(7)	(8)	(9)

(1) STX (Start of Text)

This control code indicates the start of a command. The character code is CHR\$(2).

(2) Address Number (01 to 31)

Address numbers are used by a higher-level device to identify which CW120/121 to communicate with. (ID number of the CW120/121)

(3) CPU Number

This number is fixed to 01.

(4) Time to Wait for Response

This is fixed to 0.

(5) Command (See subsection 5.4)

Specify a command to be issued from the higher-level device.

(6) Data Corresponding to Command

Specify an internal register (D register or I relay), number of data items, parameter of CW120/121 values, or others.

(7) Check sum

In PC link communication with sum check, the ASCII codes of the text between STX and the checksum are converted into hexadecimal values and added on a byte basis. Then the lowermost byte of the added results is turned into ASCII code, and its lower byte is used as the checksum.

This 2-byte space is unnecessary for PC link communication without sum check.

(8) ETX (End of Text)

This control code indicates the end of a command string. The character code is CHR\$(3).

(9) CR (Carriage Return)

This control code marks the end of a command. The character code is CHR\$(13).



NOTE

The control codes STX, ETX, and CR in commands are indispensable. Do not miss any of them when you create a communication program for PC link communication. A communication failure will result if any of them are omitted or if the order is incorrect.

5.1.2 Configuration of Response

Responses from a CW120/121 with respect to a command sent from the higher-level device consist of the elements shown below, which differ depending on the condition of communication – normal or failure.

1) With Normal Communication

When communication is carried out normally, the CW120/121 returns the character string “OK” and, in response to read commands, also returns read-out data.

Number of bytes	1	2	2	2	Variable length	2	1	1
Element	STX	Address number (Station number)	CPU number: 01	OK	Parameter data	Checksum	ETX	CR

2) In the Event of Failure

If communication is carried out abnormally, the CW120/121 returns the character string “ER” and error codes (EC1 and EC2). (See subsection 5.3, Response Error Codes.)

- No response is made in case of an error in address number specification or CPU number specification.
- If a CW120/121 cannot receive an ETX contained in a command, a response may not be made.

* As a measure against these situations, provide a timeout processing in the communication functions or communication programs of the higher-level device.

Number of bytes	1	2	2	2	2	(2)	3	2	1	1
Element	STX	Address number (Station number)	CPU number: 01	ER	EC1	(EC2)	Command	Checksum	ETX	CR

5.2 Communication with Higher-level Device

In PC link communication, when specifying D registers or I relays (internal registers of CW120/121), you can use the numbers as is. The numbers of these internal registers are in the following format:

- D register: Dxxxx (xxxx is D register number.)
- I relay: Ixxxx (xxxx is I relay number.)

Higher-level devices to be connected to a CW120/121 are those capable of handling the PC link communication protocol.

Communication with FA-M3 with UT-link module

No ladder communication program is required to communicate with FA-M3 with UT-link module (Yokogawa PLC). The UT-link module's function offers 3 modes, in which users can exchange data without paying attention to the communication procedure. (For more information, see the user's manual of UT-link module "IM 34M6H25-01E.")

- Non-user-specifiable mode: Always reads the predetermined devices* of the CW120/121 (users cannot specify devices).
- Predetermined devices* of CW120/121: D0001 to D0022
(Since these devices* are in the read only area of CW120/121, they cannot be written to.)
- User-specifiable mode: Always reads/writes the user-specified devices* of the CW120/121.
- Command mode: Accesses the devices* of the CW120/121 only when necessary.

*: "Predetermined device" or "device" here denotes the internal registers of the CW120/121 (D registers and I relays).

5.3 Response Error Codes

The error codes (EC1) and detailed error codes (EC2) of response are as follows.

EC2 is no-meaning when error code (EC1) is not included in following table 5.2.

Table 5.1 Error Codes (EC1)

Error code	Meaning	Causes
02	Command error	<ul style="list-style-type: none"> The command does not exist. Command not executable
03	Internal register specification error	<ul style="list-style-type: none"> Specified register number does not exist. In handling bit registers (I relays) on a word-by-word basis, its specification is not correct.
04	Out of setting range	<ul style="list-style-type: none"> A character other than 0 and 1 was used for bit setting. A value other than 0000 to FFFF was specified in the word specification. The start address specified for data loading/saving is out of the address range.
05	Data number error	<ul style="list-style-type: none"> Specified number of bits or words is too large. The number of data or registers specified and the number of parameters for them are inconsistent.
06	Monitor error	<ul style="list-style-type: none"> An attempt was made to execute monitoring without specifying any device to be monitored (BRS or WRS).
08	Parameter error	<ul style="list-style-type: none"> Wrong parameter.
42	Sum error	<ul style="list-style-type: none"> The sum does not match.
43	Internal buffer overflow	<ul style="list-style-type: none"> Too much data was received.
44	Timeout between received characters	<ul style="list-style-type: none"> No terminal character or ETX is received.

Table 5.2 Detailed Error Codes (EC2)

Error code (EC1)	Meaning	Detailed error code (EC2)
03	Internal register specification error	Indicates the parameter number where an error occurred. This is the number of a parameter in sequence that first resulted in an error when counted from the leading parameter. Example: <div style="text-align: center;"> Error in internal register specification ↓ STX 01010RW 02 D0043, 3F80, A0044, 0000 Parameter number 1 2 3 4 5 </div> In this case, EC1 = 03 and EC2 = 04
04	Out of setting range	
05	Data number error	
08	Parameter error	

5.4 List of Commands

The following are the lists of commands available in PC link communication.

Table 5.3 Bit-basis Access Commands Dedicated to I Relays

Command	Description	Number of bits handled
BRD	Bit-basis read	1 to 48 bits
BWR	Bit-basis write	1 to 32 bits
BRR	Bit-basis, random read	1 to 16 bits
BRW	Bit-basis, random write	1 to 16 bits
BRS	Specifies I relays to be monitored on a bit-by-bit basis.	1 to 16 bits
BRM	Bit-basis monitoring	

Table 5.4 Word-basis Access Commands

Command	Description	Number of words handled
WRD	Word-basis read	1 to 64 words
WWR	Word-basis write	1 to 64 words
WRR	Word-basis, random read	1 to 32 words
WRW	Word-basis, random write	1 to 32 words
WRS	Specifies internal registers to be monitored on a word-by-word basis.	1 to 24 words
WRM	Word-basis monitoring	

Table 5.5 Special Commands

Command	Description	Number of controllers handled
INF	Reads model, version, and revision.	—

The device names (-summary name of D register and I relay -) given as to parameter of command have following formats.

- D register: Dxxxx (xxxx is D register number.)
- I relay: Ixxxx (xxxx is I relay number.)

5.4.1 BRD Reads I relays on a bit-by-bit basis.

● **Function**

Reads the ON/OFF statuses of a sequence of contiguous I relays by the specified number of bits, starting at a specified I relay number.

- The number of bits to be read at a time is 1 to 48.
- For the format of response in the event of failure, see subsection 5.1.2.
- The command shown below includes the checksum function. When performing communication without checksum, do not include the 2-byte checksum element in the command.

● **Command/Response (for normal operation)**

Number of Bytes	1	2	2	1	3	5	1	3	2	1	1
Command element	STX	Address (Station number)	CPU number 01	0	BRD	I relay number	Comma or space	Number of bits (n)	Check sum	ETX	CR

Number of Bytes	1	2	2	2	1	1	1		1	2	1	1
Response element	STX	Address (Station number)	CPU number 01	OK	d1	d2	d3		dn	Check sum	ETX	CR

The response parameter data is 0 when the status is OFF or 1 when ON.

dn: read data of the specified number of bits (n = 1 to 48)
 dn = 0 (OFF)
 dn = 1 (ON)

● **Example:** Reading the input overrange against full input scale of the CW120/121 with address number 01.

The following command reads the status of I0001 at address number 01.

[Command] **[STX]01010BRDII0001, 001[ETX][CR]**

The following response is returned with respect to the above command. (When I0001 is ON.)

[Response] **[STX]0101OK1[ETX][CR]**

↑
I0001 has been ON since 1 was returned.

5.4.2 BWR Writes data into I relays on a bit-by-bit basis.

● Function

Writes ON/OFF data into a sequence of contiguous I relays by the specified number of bits, starting at a specified I relay number.

- The number of bits to be written at a time is 1 to 32.
- For the format of response in the event of failure, see subsection 5.1.2.
- The command shown below includes a checksum function. When performing communication without checksum, do not include the 2-byte checksum element in the command.

● Command/Response (for normal operation)

Number of Bytes	1	2	2	1	3	5	1	3	1	1	1
Command element	STX	Address (Station number)	CPU number 01	0	BWR	I relay number	Comma or space	Number of bits (n)	Comma or space	d1	d2

Command (continued)

	1	2	1	1
	dn	Check sum	ETX	CR

Write information is 0 to set OFF or 1 to set ON.

(dn: write data of the specified number of bits (n = 1 to 32)
 dn = 0 (OFF)
 dn = 1 (ON))

Number of Bytes	1	2	2	2	2	1	1
Response element	STX	Address (Station number)	CPU number 01	OK	Check sum	ETX	CR

- **Example:** Setting the Remote reset (I0010) of the CW120/121 with address number 01 to ON.

[Command] [STX]01010BWRI0010, 001, 1[ETX][CR]

“OK” is returned in response to the command above.

[Response] [STX]0101OK[ETX][CR]

5.4.3 BRR Reads I relays on a bit-by-bit basis in a random order.

● **Function**

Reads the ON/OFF statuses of the individual I relays specified in a random order by the specified number of bits.

- The number of bits to be read at a time is 1 to 16.
- For the format of response in the event of failure, see subsection 5.1.2.
- The command shown below includes a checksum function. When performing communication without the checksum, do not include the 2-byte checksum element in the command.

● **Command/Response (for normal operation)**

Number of Bytes	1	2	2	1	3	2	5	1	5	1
Command element	STX	Address (Station number)	CPU number 01	0	BRR	Number of bits (n)	I relay number 1	Comma or space	I relay number 2	Comma or space

Command (continued)

	5	2	1	1
	I relay number n	Checksum	ETX	CR

Number of Bytes	1	2	2	2	1	1		1	2	1	1
Response element	STX	Address (Station number)	CPU number 01	OK	d1	d2		dn	Checksum	ETX	CR

The response parameter data is 0 when the status is OFF or 1 when ON.

dn: read data of the specified number of bits (n = 1 to 32)
 dn = 0 (OFF)
 dn = 1 (ON)

● **Example:** Reading the Input overrange against full input scale (I0001) and the Remote reset (I0010) of the CW120/121 with address number 01.

[Command] **[STX]01010BRR02I0001, I0010 [ETX][CR]**

In response to the command above, the ON and OFF responses are returned for I0001 and I0010 respectively.

[Response] **[STX]0101OK10[ETX][CR]**

↑
I0001 is ON, and I0010 is OFF.

5.4.4 BRW Writes data into I relays on a bit-by-bit basis in a random order.

● Function

Writes ON/OFF statuses in the individual I relays specified in a random order by the specified number of bits.

- The number of bits to be written at a time is 1 to 16.
- For the format of response in the event of failure, see subsection 5.1.2.
- The command shown below includes the checksum function. When performing communication without the checksum, do not include the 2-byte checksum element in the command.

● Command/Response (for normal operation)

Number of Bytes	1	2	2	1	3	2	5	1	1	1	5
Command element	STX	Address (Station number)	CPU number 01	0	BRW	Number of bits (n)	I relay number 1	Comma or space	d1	Comma or space	I relay number 2

Command (continued)

1	1	1		5	1	1	2	1	1
Comma or space	d2	Comma or space		I relay number n	Comma or space	dn	Check sum	ETX	CR

Write information is 0 to set OFF or 1 to set ON.

dn: write data of the specified number of bits (n = 1 to 32)
 dn = 0 (OFF)
 dn = 1 (ON)

Number of Bytes	1	2	2	2	2	1	1
Response element	STX	Address (Station number)	CPU number 01	OK	Check sum	ETX	CR

- **Example:** Setting the Remote reset (I0010) and the Stop of optional power integration (I0014) of the CW120/121 with address number 01 to ON and OFF.

[Command] [STX]01010BRW02I0010, 1, I0014, 0[ETX][CR]

“OK” is returned in response to the command above.

[Response] [STX]0101OK[ETX][CR]

5.4.5 BRS Specifies I relays to be monitored on a bit-by-bit basis.

● **Function**

Specifies the numbers of I relays to be monitored on a bit-by-bit basis. Note that this command simply specifies I relays. Actual monitoring is performed by the BRM command after the I relay numbers are specified with this command.

When the volume of data is large and you wish to increase the communication rate, it is effective to use a combination of the BRS and BRM commands rather than the BRD or BRR command. If the power supply is turned off, the specified I relay numbers will be erased.

- The number of registers to be specified at a time is 1 to 16.
- For the format of response in the event of failure, see subsection 5.1.2.
- The command shown below includes the checksum function. When performing communication without the checksum, do not include the 2-byte checksum element in the command.

● **Command/Response (for normal operation)**

Number of Bytes	1	2	2	1	3	2	5	1	5	1
Command element	STX	Address (Station number)	CPU number 01	0	BRS	Number of bits (n)	I relay number 1	Comma or space	I relay number 2	Comma or space

Command (continued)

	5	2	1	1
	I relay number n	Checksum	ETX	CR

Number of Bytes	1	2	2	2	2	1	1
Response element	STX	Address (Station number)	CPU number 01	OK	Checksum	ETX	CR

- **Example:** Monitoring the Input overrange against full input scale (I0001) and the Remote reset (I0010) of the CW120/121 with address number 01.

(This command is used simply for specifying registers.)

[Command] [STX]01010BRS01I0001,I0010[ETX][CR]

“OK” is returned in response to the command above.

[Response] [STX]0101OK[ETX][CR]

5.4.6 BRM Monitors I relays on a bit-by-bit basis.

● Function

Reads the ON/OFF statuses of the I relays that have been once specified in advance by the BRS command.

- Before executing this command, the BRS command must always be executed to specify which I relays are to be monitored. If no relay has been specified, error code 06 is returned. This error also occurs if the power supply is turned off.
- For the format of response in the event of failure, see subsection 5.1.2.
- The command shown below includes the checksum function. When performing communication without the checksum, do not include the 2-byte checksum element in the command.

● Command/Response (for normal operation)

Number of Bytes	1	2	2	1	3	2	1	1
Command element	STX	Address (Station number)	CPU number 01	0	BRM	Check sum	ETX	CR

Number of Bytes	1	2	2	2	1	1	1		1	2	1	1
Response element	STX	Address (Station number)	CPU number 01	OK	d1	d2	d3		dn	Check sum	ETX	CR

The response parameter data is 0 when the status is OFF and 1 when ON.

$\left(\begin{array}{l} \text{dn: read data of the number of bits specified by the BRS command (n = 1 to 16)} \\ \text{dn = 0 (OFF)} \\ \text{dn = 1 (ON)} \end{array} \right)$

- **Example:** Monitoring the Input overrange against full input scale (I0001) and the Remote reset (I0010) of the CW120/121 with address number 01.

(This command reads the statuses of the I relays specified by the BRS command.)

[Command] [STX]01010BRM[ETX][CR]

The ON/OFF status of the I relay is returned in response to the command above.

[Response] [STX]0101OK11[ETX][CR]

↑ The I relay is ON.

5.4.7 WRD Reads D registers and I relays on a word-by-word basis.

● **Function**

Reads a sequence of contiguous register information on a word-by-word basis by the specified number of words, starting at the specified register number.

- The number of words to be read at a time is 1 to 64.
- For the format of response in the event of failure, see subsection 5.1.2.
- The command shown below includes the checksum function. When performing communication without the checksum, do not include the 2-byte checksum element in the command.

● **Command/Response (for normal operation)**

Number of Bytes	1	2	2	1	3	5	1	2	2	1	1
Command element	STX	Address (Station number)	CPU number 01	0	WRD	Register number	Comma or space	Number of words (n)	Check sum	ETX	CR

Number of Bytes	1	2	2	2	4	4		4	2	1	1
Response element	STX	Address (Station number)	CPU number 01	OK	dddd1	dddd2		ddddn	Check sum	ETX	CR

The response is returned in a 4-digit character string (0000 to FFFF) in a hexadecimal pattern.

(ddddn: Read data of the specified number of words
 ddddn = character string in a hexadecimal pattern
 n = 1 to 64)

- **Example:** Reading the Integrated power (uint32; lower-order 2 bytes) (D0001) and the Integrated power (uint32; higher-order 2 bytes) (D0002) of the CW120/121 with address number 01.

[Command] [STX]01010WRDD0001, 02[ETX][CR]

The Integrated power (uint32; lower-order 2 bytes) (D0001) value (03E8(HEX)) and the Integrated power (uint32; higher-order 2 bytes) (D0002) value (00C8 (HEX)) is returned in response to the command above.

[Response] [STX]0101OK03E800C8[ETX][CR]

5.4.8 WWR Writes data into D registers and I relays on a word-by-word basis.

● Function

Writes information into a sequence of contiguous registers on a word-by-word basis by the specified number of words, starting at the specified register number.

- The number of words to be written at a time is 1 to 64.
- For the format of response in the event of failure, see subsection 5.1.2.
- The command shown below includes the checksum function. When performing communication without the checksum, do not include the 2-byte checksum element in the command.

● Command/Response (for normal operation)

Number of Bytes	1	2	2	1	3	5	1	2	1	4
Command element	STX	Address (Station number)	CPU number 01	0	WWR	Register number	Comma or space	Number of words (n)	Comma or space	dddd1

Command (continued)

4		4	2	1	1
dddd2		ddddn	Check sum	ETX	CR

Write information is specified in a 4-digit character string (0000 to FFFF) in a hexadecimal pattern.

(dddd: Write data of the specified number of words
 ddddn = character string in a hexadecimal pattern
 n = 1 to 64)

Number of Bytes	1	2	2	2	2	1	1
Response element	STX	Address (Station number)	CPU number 01	OK	Check sum	ETX	CR

- **Example:** Writing 0380(HEX) into the PT ratio (float upper 2 bytes) (D0044) and 0000(HEX) into the PT ratio (float lower 2 bytes) (D0043) of the CW120/121 with address number 01.

[Command] [STX]01010WWRD0043, 02, 03800000[ETX][CR]

“OK” is returned in response to the command above.

[Response] [STX]0101OK[ETX][CR]

5.4.9 WRR Reads D registers and I relays on a word-by-word basis in random order.

● **Function**

Reads the statuses of the individual registers, on a word-by-word basis, specified in a random order by the specified number of words.

- The number of words to be read at a time is 1 to 32.
- For the format of response in the event of failure, see subsection 5.1.2.
- The command shown below includes the checksum function. When performing communication without the checksum, do not include the 2-byte checksum element in the command.

● **Command/Response (for normal operation)**

Number of Bytes	1	2	2	1	3	2	5	1	5	1
Command element	STX	Address (Station number)	CPU number 01	0	WRR	Number of words (n)	Register number 1	Comma or space	Register number 2	Comma or space

Command (continued)

	5	2	1	1
	Register number (n)	Check sum	ETX	CR

Number of Bytes	1	2	2	2	4	4		4	2	1	1
Response element	STX	Address (Station number)	CPU number 01	OK	dddd1	dddd2		dddn	Check sum	ETX	CR

The response is returned in a 4-digit character string (0000 to FFFF) in a hexadecimal pattern. ddddn = character string in a hexadecimal pattern (n = 1 to 32)

- **Example:** Reading the Integrated pulse Characteristic (int 16 bits) (D0051) and the area for user (D0104) of the CW120/121 with address number 01.

[Command] **[STX]01010WRR02D0051,D104[ETX][CR]**

The Intergrated pulse Characteristic (int 16 bits) (D0051) value 00C8 (HEX) and the area for user (D0104) value 0032 (HEX) are returned as the response to the above command.

[Response] **[STX]01010OK00C80032[ETX][CR]**

5.4.10 WRW Writes data into D registers and I relays on a word-by-word basis in random order.

● Function

Writes register information specified for each register into the registers specified in a random order by the specified number of words.

- The number of words to be written at a time is 1 to 32.
- For the format of response in the event of failure, see subsection 5.1.2.
- The command shown below includes the checksum function. When performing communication without the checksum, do not include the 2-byte checksum element in the command.

● Command/Response (for normal operation)

Number of Bytes	1	2	2	1	3	2	5	1	4	1
Command element	STX	Address (Station number)	CPU number 01	0	WRW	Number of words (n)	Register number 1	Comma or space	ddd1	Comma or space

Command (continued)

5	1	4		5	1	4	2	1	1
Register number 2	Comma or space	ddd2		Register number n	Comma or space	dddn	Checksum	ETX	CR

Write information is specified in a 4-digit character string (0000 to FFFF) in a hexadecimal pattern.

dddn: Repetition of register data and write information of the specified number of words
 ddddn = character string in a hexadecimal pattern
 n = 1 to 32

Number of Bytes	1	2	2	2	2	1	1
Response element	STX	Address (Station number)	CPU number 01	OK	Checksum	ETX	CR

- **Example:** Writing 0014(HEX) into the area for user (D0104) and 0005(HEX) into the area for user (D0105) of the CW120/121 with address number 01.

[Command] [STX]01010WRW02D0104, 0014, D0105, 0005[ETX][CR]

“OK” is returned in response to the command above.

[Response] [STX]0101OK[ETX][CR]

5.4.11 WRS Specifies the D registers and I relays to be monitored on a word-by-word basis.

● Function

Specifies the numbers of the registers to be monitored on a word-by-word basis. Note that this command simply specifies the registers. Actual monitoring is performed by the WRM command after the register numbers are specified by this command.

If the volume of data is large and you wish to increase the communication rate, it is effective to use a combination of the WRS and WRM commands rather than the WRD or WRR command. If the power supply is turned off, the register numbers specified will be erased.

- The number of words to be specified at a time is 1 to 24.
- For the format of response in the event of failure, see subsection 5.1.2.
- The command shown below includes the checksum function. When performing communication without the checksum, do not include the 2-byte checksum element in the command.

● Command/Response (for normal operation)

Number of Bytes	1	2	2	1	3	2	5	1	5	1
Command element	STX	Address (Station number)	CPU number 01	0	WRS	Number of words (n)	Register number 1	Comma or space	Register number 2	Comma or space

Command (continued)

	5	2	1	1
	Register number n	Check sum	ETX	CR

Number of Bytes	1	2	2	2	2	1	1
Response element	STX	Address (Station number)	CPU number 01	OK	Check sum	ETX	CR

- **Example:** Monitoring the integrated power (uint32; lower-order 2 bytes) (D0001) and the integrated power (uint32; higher-order 2 bytes) (D0002) of the CW120/121 with address number 01.

(This command simply specifies the registers.)

[Command] [STX]01010WRS02D0001,D0002[ETX][CR]

“OK” is returned in response to the command above.

[Response] [STX]0101OK[ETX][CR]

5.4.12 WRM Monitors the D register and I relays on a word-by-word basis.

● Function

Reads the information of the registers that have been specified in advance by the WRS command.

- Before executing this command, the WRS command must once be executed to specify which registers are to be monitored. If no register has been specified, error code 06 is returned. This error also occurs if the power supply is turned off.
- For the format of response in the event of failure, see subsection 5.1.2.
- The command shown below includes the checksum function. When performing communication without the checksum, do not include the 2-byte checksum element in the command.

● Command/Response (for normal operation)

Number of Bytes	1	2	2	1	3	2	1	1
Command element	STX	Address (Station number)	CPU number 01	0	WRM	Check sum	ETX	CR

Number of Bytes	1	2	2	2	4	4		4	2	1	1
Response element	STX	Address (Station number)	CPU number 01	OK	dddd 1	dddd 2		dddd n	Check sum	ETX	CR

The response is returned in a 4-digit character string (0000 to FFFF) in a hexadecimal pattern.

(dddd: Read data of the number of words specified by the WRS command)
 (dddd = character string in a hexadecimal pattern)
 (n = 1 to 24)

- **Example:** Monitoring the integrated power (uint32; lower-order 2 bytes) (D0001) and the integrated power (uint32; higher-order 2 bytes) (D0002) of a CW120/121 with address number 01.

(This command reads the status of the register specified by the WRS command.)

[Command] **[STX]01010WRM[ETX][CR]**

The integrated power (uint32; lower-order 2 bytes) (D0001) value 0001 (HEX) and the integrated power (uint32; higher-order 2 bytes) (D0002) value E02F(HEX) are returned in response to the command above.

[Response] **[STX]0101OK0001E02F[ETX][CR]**

5.4.13 INF Reads the model, version, and revision information.

● **Function**

Reads the model code, version number, and revision number of the Power Monitor.

- For the format of response in the event of failure, see subsection 5.1.2.

● **Command/Response (for normal operation)**

Number of Bytes	1	2	2	1	3	1	2	1	1
Command element	STX	Address (Station number)	CPU number 01	Response time: 0	INF	6	Check sum	ETX	CR

Number of Bytes	1	2	2	2	8	8	4	4
Response element	STX	Address (Station number)	CPU number 01	OK	Model and Option (Note 1)	Version and revision numbers (Note 2)	0001 (Note 3)	0022 (Note 3)

Response (continued)

4	4	2	1	1
0001 (Note 3)	0000 (Note 3)	Check sum	ETX	CR

Note 1: [Model • Option]

- When single-phase two-wire: PR201101
- When single-phase three-wire: PR201201
- When three-phase three-wire: PR201301
- When three-phase four-wire: PR201401
- When single-phase two-wire × 2: PR201101
- When single-phase two-wire × 3: PR201101

Note 2: [Version • Revision] _V00.R00

First column character (i.e. “_” in sample) indicates space.

Note 3: These are manufacture’s matter, so ignore those items.

6. Functions and Usage of D Registers and I Relays

6.1 Functions and Usage of D Registers

Various types of data are allocated to the D registers of the CW120/121. A higher-level device can acquire data from the CW120/121 or control the CW120/121 by accessing these D registers through MODBUS personal computer link communication.

As shown in Table 6.1, D registers are classified into “Common registers of power monitor PR201” and “Dedicated registers of CW120/121”.

The common registers of the power monitor PR201 are used when the CW120/121 is handled as a PR201 power monitor in a virtual manner in a PR201-supported application used by the higher-level device.

The dedicated registers of the CW120/121 are used for functions and data specific to the CW120/121.

Table 6.1 D Register Configuration

Register Number	Application	Classification	Description
D0001 to D0040	Common registers of power monitor PR201	Process data	Measured values, e.g., electric energy
D0043 to D0058		Parameter data	Setting condition, e.g., VT and CT ratios
D0059		No operation data	Not supported with CW120/121
D0060		Control data	Reset of electric energy
D0061 to D0063		No operation data	Not supported with CW120/121
D0064 to D0071		Prohibited area	Cannot be used. Reading from/writing to this is not guaranteed.
D0072		Setpoint change status	Switch serving as a trigger for setpoint change.
D0073 to D0100		Registers for which use is prohibited	Prohibited area
D0101 to D0150	Common registers of power monitor PR201	User area	Can be used freely by the user.
D0151 to D0500	Registers for which use is prohibited	Prohibited area	Cannot be used. Reading from/writing to this is not guaranteed.
D0501 to D0524	Dedicated registers of CW120/121	Process data	Measured values, e.g., electric energy
D0525 to D0528		Prohibited area	Cannot be used. Reading from/writing to this is not guaranteed.
D0529 to D0566 and D0577		Parameter data	Setting condition, e.g., VT and CT ratios
D0567 to D0572		Control data	Operation control, e.g., system reset.
D0573		Setpoint change status	Switch serving as a trigger for setpoint change.
D0574 to D0576		Parameter data	Fixed values, e.g., model name
D0581 to D0628		Process data	Measured values, e.g., electric energy
Others		Registers for which use is prohibited	Prohibited area

6.1.1 Power Monitor PR201 Common Register Map

The following lists common register areas used by both CW120/121 and Power Monitor PR201.

Table 6.2 D Register Map and Common Registers of Power Monitor PR201 (1/3)

D-Reg No.	Ref No.	H No.	Register Description	Power Monitor Data Range	CW120/121 Data Range and Data Processing	Read/Write		
D0001	40001	0000	Active electric energy (uint 32; lower-order 2 bytes)	0 to 99999999 kWh	0 to 99999999 kWh	Read		
D0002	40002	0001	Active electric energy (uint 32; higher-order 2 bytes)			Read		
D0003	40003	0002	Optional active electric energy – current send value (uint 32; lower-order 2 bytes)	0 to 99999 Wh	0	Read		
D0004	40004	0003	Optional active electric elergy – current send value (uint 32; higher-order 2 bytes)			Read		
D0005	40005	0004	Optional active electric energy – previous send value (uint 32; lower-order 2 bytes)			Read		
D0006	40006	0005	Optional active electric energy – previous send value (uint 32; higher-order 2 bytes)			Read		
D0007	40007	0006	Instantaneous value of active power (float; lower-order 2 bytes)			0 W to ±9999 MW	0 W to +9999 MW	Read
D0008	40008	0007	Instantaneous value of active power (float; higher-order 2 bytes)	"----" 0 "Or" Voltage range: 150 V, 300 V Rated power range: × 1.69 Voltage range: 450 V Rated power range: × 1.4	Read			
D0009	40009	0008	Voltage 1 (float; lower-order 2 bytes)	0.0 V to 9999 kV	0.0 V to 4.95 MW	Read		
D0010	40010	0009	Voltage 1 (float; higher-order 2 bytes)			Read		
D0011	40011	0010	Voltage 2 (float; lower-order 2 bytes)			"----" 0	Read	
D0012	40012	0011	Voltage 2 (float; higher-order 2 bytes)			"Or" Voltage range: 150 V, 300 V Rated voltage range: × 1.3 Voltage range: 450 V Rated voltage range: × 1.1	Read	
D0013	40013	0012	Voltage 3 (float; lower-order 2 bytes)				Read	
D0014	40014	0013	Voltage 3 (float; higher-order 2 bytes)				Read	
D0015	40015	0014	Current 1 (float; lower-order 2 bytes)				0.0 A to 9999 kA	0.0 A to 13.0 MW
D0016	40016	0015	Current 1 (float; higher-order 2 bytes)			Read		
D0017	40017	0016	Current 2 (float; lower-order 2 bytes)	"----" 0	Read			
D0018	40018	0017	Current 2 (float; higher-order 2 bytes)	"Or" Rated current range: × 1.3	Read			
D0019	40019	0018	Current 3 (float; lower-order 2 bytes)		Read			
D0020	40020	0019	Current 3 (float; higher-order 2 bytes)		Read			
D0021	40021	0020	Power factor (float; lower-order 2 bytes)		-0.500 to 1.000 to +0.500	-0.500 to 1.000 to +0.500		
D0022	40022	0021	Power factor (float; higher-order 2 bytes)	"----" 0 "Or"			Read	
D0023	40023	0022	Voltage 1 maximum value (float; lower-order 2 bytes)	0.0 V to 9999 kV	0	Read		
D0024	40024	0023	Voltage 1 maximum value (float; higher-order 2 bytes)			Read		
D0025	40025	0024	Voltage 1 minimum value (float; lower-order 2 bytes)			Read		
D0026	40026	0025	Voltage 1 minimum value (float; higher-order 2 bytes)			Read		
D0027	40027	0026	Voltage 2 maximum value (float; lower-order 2 bytes)			Read		
D0028	40028	0027	Voltage 2 maximum value (float; higher-order 2 bytes)			Read		
D0029	40029	0028	Voltage 2 minimum value (float; lower-order 2 bytes)			Read		
D0030	40030	0029	Voltage 2 minimum value (float; higher-order 2 bytes)			Read		
D0031	40031	0030	Voltage 3 maximum value (float; lower-order 2 bytes)			Read		

Table 6.2 D Register Map and Common Registers of Power Monitor PR201 (2/3)

D-Reg No.	Ref No.	H No.	Register Description	Power Monitor Data Range	CW120/121 Data Range and Data Processing	Read/Write
D0032	40032	0031	Voltage 3 maximum value (float; higher-order 2 bytes)	0.0 V to 9999 kV	0	Read
D0033	40033	0032	Voltage 3 minimum value (float; lower-order 2 bytes)			Read
D0034	40034	0033	Voltage 3 minimum value (float; higher-order 2 bytes)			Read
D0035	40035	0034	Current 1 maximum value (float; lower-order 2 bytes)	0.0 A to 9999 kA	0	Read
D0036	40036	0035	Current 1 maximum value (float; higher-order 2 bytes)			Read
D0037	40037	0036	Current 2 maximum value (float; lower-order 2 bytes)			Read
D0038	40038	0037	Current 2 maximum value (float; higher-order 2 bytes)			Read
D0039	40039	0038	Current 3 maximum value (float; lower-order 2 bytes)			Read
D0040	40040	0039	Current 3 maximum value (float; higher-order 2 bytes)			Read
D0041	40041	0040				
D0042	40042	0041				
D0043	40043	0042	VT ratio (float; lower-order 2 bytes)	1 to 32000	1 to 10000	Read/Write
D0044	40044	0043	VT ratio (float; higher-order 2 bytes)			Read/Write
D0045	40045	0044	CT ratio (float; lower-order 2 bytes)	0.05 to 32000	1.00 to 10000.00	Read/Write
D0046	40046	0045	CT ratio (float; higher-order 2 bytes)			Read/Write
D0047	40047	0046	Integrated low-cut power (float; lower-order 2 bytes)	0.1 to 99.9 W	Read: 0 Write: No operation	Read/Write
D0048	40048	0047	Integrated low-cut power (float; higher-order 2 bytes)			Read/Write
D0049	40049	0048	Integrated pulse unit mantissa (float; lower-order 2 bytes)	1.000 to 9.999	Read: 0 Write: No operation	Read/Write
D0050	40050	0049	Integrated pulse unit mantissa (float; higher-order 2 bytes)			Read/Write
D0051	40051	0050	Integrated pulse unit exponent (int; 16 bits)	-6 to -1	Read: 0 Write: No operation	Read/Write
D0052	40052	0051	Integrated pulse ON pulse width (uint; 16 bits)	1 to 127	Read: 0 Write: No operation	Read/Write
D0053	40053	0052	Input scaling "L" level setting for analog output (float; lower-order 2 bytes)	-4800 to +4800	Read: 0 Write: No operation	Read/Write
D0054	40054	0053	Input scaling "L" level setting for analog output (float; higher-order 2 bytes)			Read/Write
D0055	40055	0054	Input scaling "H" level setting for analog output (float; lower-order 2 bytes)	-4800 to +4800	Read: 0 Write: No operation	Read/Write
D0056	40056	0055	Input scaling "H" level setting for analog output (float; higher-order 2 bytes)			Read/Write
D0057	40057	0056	Active electric energy setting (uint 32; lower-order 2 bytes)	0 to 99999999 kWh	No operation	Write
D0058	40058	0057	Active electric energy setting (uint 32; higher-order 2 bytes)			Write
D0059	40059	0058	Remote reset	1: Power meter reset Other than 1: No operation	No operation	Write

Note: float: Single precision floating decimal point
uint: Without sign integer
int: With sign integer
"Or": The input value is over the range.

Table 6.2 D Register Map and Common Registers of Power Monitor PR201 (3/3)

D-Reg No.	Ref No.	H No.	Register Description	Power Monitor Data Range	CW120/121 Data Range and Data Processing	Read/Write
D0060	40060	0059	Electric energy reset	1: Electric energy reset Other than 1: No operation	1: Electric energy reset If integration is in progress, stops integration and resets. Then resumes integration. Other than 1: No operation	Write
D0061	40061	0060	Maximum/minimum value reset	1: Maximum/minimum value reset Other than 1: No operation	No operation	Write
D0062	40062	0061	Start of optional integrated power	1: Start of optional integration Other than 1: No operation	No operation	Write
D0063	40063	0062	Stop of optional integrated power	1: Stop of optional integration Other than 1: No operation	No operation	Write
D0064	40064	0063	Use prohibited			
D0065	40065	0064				
D0066	40066	0065				
D0067	40067	0066				
D0068	40068	0067				
D0069	40069	0068				
D0070	40070	0069				
D0071	40071	0070				
D0072	40072	0071	Setpoint change status	1: Setting value set Other than 1: No operation	1: D0043 to D0046 setting values are set Other than 1: No operation	Write

Note: float: Single precision floating decimal point
 uint: Without sign integer
 int: With sign integer
 "Or": The input value is over the range.
 "----": Measurement not possible because input value is out of measurement range.

6.1.2 CW120/121 Dedicated Register Map

The following lists the dedicated register areas of the CW120/121.

Table 6.3 D Register Map and Dedicated Registers of CW120/121 (1/4)

D-Reg No.	Ref No.	H No.	Register Description	Data Range	Read/Write				
D0501	40501	0500	Voltage 1 (float; lower-order 2 bytes)	□.□□□E ±□□V "----": 3.402823E+38 "Or": -3.402823E+38	Read				
D0502	40502	0501	Voltage 1 (float; upper-order 2 bytes)		□.□□□E ±□□A "----": 3.402823E+38 "Or": -3.402823E+38	Read			
D0503	40503	0502	Voltage 2 (float; lower-order 2 bytes)			±□.□□□E ±□□Var "----": 3.402823E+38 "Or": -3.402823E+38	Read		
D0504	40504	0503	Voltage 2 (float; upper-order 2 bytes)				-1.000 to +1.000 "----": 3.402823E+38 "Or": -3.402823E+38	Read	
D0505	40505	0504	Voltage 3 (float; lower-order 2 bytes)					40.00 to 70.00Hz "----": 3.402823E+38 "Or": -3.402823E+38	Read
D0506	40506	0505	Voltage 3 (float; upper-order 2 bytes)						□.□□□□E ±□□Wh □.□□□□E ±□□Wh
D0507	40507	0506	Current 1 (float; lower-order 2 bytes)	Use prohibited					
D0508	40508	0507	Current 1 (float; upper-order 2 bytes)		2000 to 2099				
D0509	40509	0508	Current 2 (float; lower-order 2 bytes)			1 to 12			
D0510	40510	0509	Current 2 (float; upper-order 2 bytes)				1 to 31		
D0511	40511	0510	Current 3 (float; lower-order 2 bytes)					0 to 23	
D0512	40512	0511	Current 3 (float; upper-order 2 bytes)						0 to 59
D0513	40513	0512	Active power (float; lower-order 2 bytes)	0 to 59					
D0514	40514	0513	Active power (float; upper-order 2 bytes)		0: Normal/integrated measurement mode 1: Connection check mode				
D0515	40515	0514	Reactive power (float; lower-order 2 bytes)			0: Stop 1: Waiting 2: Performing integration			
D0516	40516	0515	Reactive power (float; upper-order 2 bytes)				0: Single-phase two-wire (1∅2 W) 1: Single-phase three-wire (1∅3 W) 2: Three-phase three-wire (3∅3 W) 3: Three-phase four-wire (3∅4 W) 4: Single-phase two-wire ×2 (1∅2 W×2) 5: Single-phase two-wire ×3 (1∅2 W×3)		
D0517	40517	0516	Power factor (float; lower-order 2 bytes)					0: 150V 1: 300V 2: 450V	
D0518	40518	0517	Power factor (float; upper-order 2 bytes)						
D0519	40519	0518	Frequency (float; lower-order 2 bytes)						
D0520	40520	0519	Frequency (float; upper-order 2 bytes)						
D0521	40521	0520	Active electric energy (float; lower-order 2 bytes)						
D0522	40522	0521	Active electric energy (float; upper-order 2 bytes)						
D0523	40523	0522	Regenerative active electric energy (float; lower-order 2 bytes)						
D0524	40524	0523	Regenerative active electric energy (float; upper-order 2 bytes)						
D0525	40525	0524	Use prohibited						
D0526	40526	0525							
D0527	40527	0526							
D0528	40528	0527							
D0529	40529	0528	System date (year) (uint 16)						
D0530	40530	0529	System date (month) (uint 16)						
D0531	40531	0530	System date (day) (uint 16)						
D0532	40532	0531	System time (hour) (uint 16)						
D0533	40533	0532	System time (minute) (uint 16)						
D0534	40534	0533	System time (second) (uint 16)						
D0535	40535	0534	Measurement mode (uint 16)						
D0036	40536	0535	Integrated measurement state (uint 16)						
D0537	40537	0536	Phase wire (uint 16)						
D0538	40538	0537	Voltage range (uint 16)						

Table 6.3 D Register Map and Dedicated Registers of CW120/121 (2/4)

D-Reg No.	Ref No.	H No.	Register Description	Data Range	Read/Write
D0539	40539	0538	Current range (uint 16)	0: 5A 1: 10A 2: 20A 3: 50A 4: 100A 5: 200A 6: 500A 7: 1000A	Read/Write
D0540	40540	0539	Clamp type (uint 16)	0: 5 to 50 A (96033) 1: 20 to 200 A (96030) 2: 50 to 500 A (96031) 3: 200 to 1000 A (96032)	Read/Write
D0541	40541	0540	CT ratio (float; lower-order 2 bytes)	1.00 to 10000.00	Read/Write
D0542	40542	0541	CT ratio (float; higher-order 2 bytes)		
D0543	40543	0542	VT ratio (float; lower-order 2 bytes)	1 to 10000	Read/Write
D0544	40544	0543	VT ratio (float; higher-order 2 bytes)		
D0545	40545	0544	Normal measurement display screen (uint 16)	0: Display item 1 1: Display item 2 2: Display item 3 3: Display item 4 4: Display item 5 5: Display item 6	Read/Write
D0546	40546	0545	Integration start method (uint 16)	0: Time specified 1: Manual	Read/Write
D0547	40547	0546	Integration start time (year) (uint 16)	2000 to 2099	Read/Write
D0548	40548	0547	Integration start time (month) (uint 16)	1 to 12	Read/Write
D0549	40549	0548	Integration start time (day) (uint 16)	1 to 31	Read/Write
D0550	40550	0549	Integration start time (hour) (uint 16)	0 to 23	Read/Write
D0551	40551	0550	Integration start time (minute) (uint 16)	0 to 59	Read/Write
D0552	40552	0551	Integration start time (second) (uint 16)	0 to 59	Read/Write
D0553	40553	0552	Integration stop time (year) (uint 16)	2000 to 2099	Read/Write
D0554	40554	0553	Integration stop time (month) (uint 16)	1 to 12	Read/Write
D0555	40555	0554	Integration stop time (day) (uint 16)	1 to 31	Read/Write
D0556	40556	0555	Integration stop time (hour) (uint 16)	0 to 23	Read/Write
D0557	40557	0556	Integration stop time (minute) (uint 16)	0 to 59	Read/Write
D0558	40558	0557	Integration stop time (second) (uint 16)	0 to 59	Read/Write
D0559	40559	0558	Data output ON/OFF (uint 16)	0: OFF 1: ON	Read/Write
D0560	40560	0559	Output interval (uint 16)	0: 1 sec 1: 2 sec 2: 5 sec 3: 10 sec 4: 15 sec 5: 30 sec 6: 1 min 7: 2 min 8: 5 min 9: 10 min 10: 15 min 11: 30 min 12: 1 hr	Read/Write
D0561	40561	0560	Saved file name (char 2; 1st and 2nd characters)	Set file name with valid characters. No file name is set if all 8 characters are set to NULL (00h).	Read/Write
D0562	40562	0561	Saved file name (char 2; 3rd and 4th characters)		Read/Write
D0563	40563	0562	Saved file name (char 2; 5th and 6th characters)		Read/Write
D0564	40564	0563	Saved file name (char 2; 7th and 8th characters)		Read/Write
D0565	40565	0564	Decimal point position of electric energy (uint 16)		0: Standard 1: 000.000 2: 0000.00 3: 00000.0 4: 000000

Table 6.3 D Register Map and Dedicated Registers of CW120/121 (3/4)

D-Reg No.	Ref No.	H No.	Register Description	Data Range	Read/Write
D0566	40566	0565	Unit of electric energy (uint 16)	0: Wh 1: kWh 2: MWh 3: GWh	Read/Write
D0567	40567	0566	ON/OFF of LCD back light (uint 16)	0: OFF 1: ON	Read/Write
D0568	40568	0567	ON/OFF of key lock (uint 16)	0: OFF 1: ON	Read/Write
D0569	40569	0568	System reset (uint 16)	1: System reset Other than 1: No operation	Write
D0570	40570	0569	Start of integration	1: Start of integration Other than 1: No operation	Write
D0571	40571	0570	Stop of integration (uint 16)	1: Stop of integration Other than 1: No operation	Write
D0572	40572	0571	Clearing of integration value (uint 16)	1: Integration value cleared Other than 1: No operation	Write
D0573	40573	0572	Settings change state (uint 16)	1: D0537 to D0566 and D0577 setting value set Other than 1: No operation	Write
D0574	40574	0573	Execution state (uint 16)	Displays of last executed state with D0569 to D0573 0: OK 1: ERROR	Read
D0575	40575	0574	Model (uint 16)	0: CW120 1: CW121	Read
D0576	40576	0575	Firmware version number (uint 16)	1.00 to 100	Read
D0577	40577	0576	Load-system (uint16)	0: Load 1 1: Load 2 2: Load 3	Read/Write
D0581	40581	0580	Voltage 1 (float; lower-order 2 byte)	□.□□□E ±□OV "----": 3.402823E+38 "Or": -3.402823E+38	Read
D0582	40582	0581	Voltage 1 (float; upper-order 2 byte)		Read
D0583	40583	0582	Voltage 2 (float; lower-order 2 byte)		
D0584	40584	0583	Voltage 2 (float; upper-order 2 byte)		
D0585	40585	0584	Voltage 3 (float; lower-order 2 byte)		Read
D0586	40586	0585	Voltage 3 (float; upper-order 2 byte)		
D0587	40587	0586	Current 1 (float; lower-order 2 byte) Current 1: Load 1 (float; lower-order 2 byte)	□.□□□E ±□OA "----": 3.402823E+38 "Or": -3.402823E+38	Read
D0588	40588	0587	Current 1 (float; upper-order 2 byte) Current 1: Load 1 (float; upper-order 2 byte)		Read
D0589	40589	0588	Current 2 (float; lower-order 2 byte)		
D0590	40590	0589	Current 2 (float; upper-order 2 byte)		
D0591	40591	0590	Current 3 (float; lower-order 2 byte)		Read
D0592	40592	0591	Current 3 (float; upper-order 2 byte)		
D0593	40593	0592	Active power (float; lower-order 2 byte) Active power: Load 1 (float; lower-order 2 byte)	±□.□□□E ±□OW "----": 3.402823E+38 "Or": -3.402823E+38	Read
D0594	40594	0593	Active power (float; upper-order 2 byte) Active power: Load 1 (float; upper-order 2 byte)		
D0595	40595	0594	Reactive power (float; lower-order 2 byte) Reactive power: Load 1 (float; lower-order 2 byte)	±□.□□□E ±□OVar "----": 3.402823E+38 "Or": -3.402823E+38	Read
D0596	40596	0595	Reactive power (float; upper-order 2 byte) Reactive power: Load 1 (float; upper-order 2 byte)		

float: Single precision floating decimal point

uint: Without sign integer

int: With sign integer

char: Character string

"Or": State of input value being overrange

"----": Measurement not possible because input value is out of measurement range

Table 6.3 D Register Map and Dedicated Registers of CW120/121 (4/4)

D-Reg No.	Ref No.	H No.	Register Description	Data Range	Read/Write
D0597	40597	0596	Power factor (float; lower-order 2 byte) Power factor: Load 1 (float; lower-order 2 byte)	-1.000 to +1.000 "----": 3.402823E+38 "Or": -3.402823E+38	Read
D0598	40598	0597	Power factor (float; upper-order 2 byte) Power factor: Load 1 (float; upper-order 2 byte)		
D0599	40599	0598	Frequency (float; lower-order 2 byte)	40.00 to 70.00 Hz "----": 3.402823E+38 "Or": -3.402823E+38	Read
D0600	40600	0599	Frequency (float; upper-order 2 byte)		
D0601	40601	0600	Active electric energy (float; lower-order 2 byte) Active electric energy: Load 1 (float; lower-order 2 byte)	□.□□□□□E ±○□Wh	Read
D0602	40602	0601	Active electric energy (float; upper-order 2 byte) Active electric energy: Load 1 (float; upper-order 2 byte)		
D0603	40603	0602	Regenerative electric energy (float; lower-order 2 byte) Regenerative electric energy: Load 1 (float; lower-order 2 byte)	□.□□□□□E ±○□Wh	Read
D0604	40604	0603	Regenerative electric energy (float; upper-order 2 byte) Regenerative electric energy: Load 1 (float; upper-order 2 byte)		
D0605	40605	0604	Current 1: Load 2 (float; lower-order 2 byte)	□.□□□E ±○□A "----": 3.402823E+38 "Or": -3.402823E+38	Read
D0606	40606	0605	Current 1: Load 2 (float; upper-order 2 byte)		
D0607	40607	0606	Active power: Load 2 (float; lower-order 2 byte)	±□.□□□E ±○□W "----": 3.402823E+38 "Or": -3.402823E+38	Read
D0608	40608	0607	Active power: Load 2 (float; upper-order 2 byte)		
D0609	40609	0608	Reactive power: Load 2 (float; lower-order 2 byte)	±□.□□□E ±○□Var "----": 3.402823E+38 "Or": -3.402823E+38	Read
D0610	40610	0609	Reactive power: Load 2 (float; upper-order 2 byte)		
D0611	40611	0610	Power factor: Load 2 (float; lower-order 2 byte)	-1.000 to +1.000 "----": 3.402823E+38 "Or": -3.402823E+38	Read
D0612	40612	0611	Power factor: Load 2 (float; upper-order 2 byte)		
D0613	40613	0612	Active electric energy: Load 2 (float; lower-order 2 byte)	□.□□□□□E ±○□Wh	Read
D0614	40614	0613	Active electric energy: Load 2 (float; upper-order 2 byte)		
D0615	40615	0614	Regenerative electric energy: Load 2 (float; lower-order 2 byte)	□.□□□□□E ±○□Wh	Read
D0616	40616	0615	Regenerative electric energy: Load 2 (float; upper-order 2 byte)		
D0617	40617	0616	Current 1: Load 3 (float; lower-order 2 byte)	□.□□□E ±○□A "----": 3.402823E+38 "Or": -3.402823E+38	Read
D0618	40618	0617	Current 1: Load 3 (float; upper-order 2 byte)		
D0619	40619	0618	Active power: Load 3 (float; lower-order 2 byte)	±□.□□□E ±○□W "----": 3.402823E+38 "Or": -3.402823E+38	Read
D0620	40620	0619	Active power: Load 3 (float; upper-order 2 byte)		
D0621	40621	0620	Reactive power: Load 3 (float; lower-order 2 byte)	±□.□□□E ±○□Var "----": 3.402823E+38 "Or": -3.402823E+38	Read
D0622	40622	0621	Reactive power: Load 3 (float; upper-order 2 byte)		
D0623	40623	0622	Power factor: Load 3 (float; lower-order 2 byte)	-1.000 to +1.000 "----": 3.402823E+38 "Or": -3.402823E+38	Read
D0624	40624	0623	Power factor: Load 3 (float; upper-order 2 byte)		
D0625	40625	0624	Active electric energy: Load 3 (float; lower-order 2 byte)	□.□□□□□E ±○□Wh	Read
D0626	40626	0625	Active electric energy: Load 3 (float; upper-order 2 byte)		
D0627	40627	0626	Regenerative electric energy: Load 3 (float; lower-order 2 byte)	□.□□□□□E ±○□Wh	Read
D0628	40628	0627	Regenerative electric energy: Load 3 (float; upper-order 2 byte)		

float: Single precision floating decimal point
 uint: Without sign integer
 int: With sign integer
 char: Character string
 "Or": State of input value being overrange

Table 6.4 Change in D Registers

(This table describes the behavior of each D register when any change is made to the parameter of the register.)

Changed Parameter	Behavior When Parameter Is Changed
VT ratio	This change only results in the saving of the setpoint in the buffer memory of the CW120/121; no change is made to the VT ratio until the status of setting change
CT ratio	This change only results in the saving of the setpoint in the buffer memory of the CW120/121; no change is made to the CT ratio until the status of setting change
Status of setting change	This change initializes operating conditions with setpoints saved in the storage buffers of the CW120/121 when the parameter is set to 1, so that these setpoints are incorporated into CW120/121 operation.
System reset	This change causes the CW120/121 to return a response message immediately after system reset when it receives 1 as the setpoint.
Electric energy reset	This change causes the CW120/121 to return a response message immediately after resetting the electric energy when it receives 1 as the setpoint.

6.2 Functions and Usage of I Relays

Overview of I Relays

Various types of information and control functions are allocated to the I relays of a CW120/121. A higher-level device can acquire data from the CW120/121 or control the CW120/121 by accessing these I relays through personal computer link communication.

Table 6.5 I Relay Configuration

I Relay Number	Classification	Description
1, 2	Error information	Error related to input overranges
10-14	Control data	Control of operations, e.g., remote reset
101-164	User area	Can be used freely by the user.
Others	Prohibited area	Cannot be used. Reading from/writing to this area is not guaranteed.

Table 6.6 Common I Relay Map of Power Monitor PR201

Relay No.	Relay Name	Processing Performed by CW120/121	Read/Write
1	Input overrange against full input scale	0	Read
2	Input overrange against analog output scaling	0	Read
3			
4			
5			
6			
7			
8			
9			
10	Remote reset		Write
11	Electric energy reset	If integration is in progress, stops integration and resets. Then resumes integration.	Write
12	Maximum/minimum value reset	No operation	Write
13	Start of optional power integration	No operation	Write
14	Stop of optional power integration	No operation	Write
15			
101	User area	User area	Read/Write
⋮	⋮		⋮
164	User area	User area	Read/Write

Table 6.7 Change in I Relays

(This table describes the behavior of each I relay when any change is made to the parameter of the relay.)

Changed Parameter	Behavior When Parameter Is Changed
Electric energy reset	This change causes the CW120/121 to return a response message immediately after resetting the electric energy when it receives 1 as the setpoint.

YOKOGAWA

Yokogawa Meters & Instruments Corporation

Yokogawa Meters & Instruments Corporation

International Sales Dept.

Tachihi Bld. No.2, 6-1-3, Sakaecho, Tachikawa-shi, Tokyo 190-8586 Japan
Phone: 81-42-534-1413, Facsimile: 81-42-534-1426

YOKOGAWA CORPORATION OF AMERICA (U.S.A.)

Phone: 1-770-253-7000 Facsimile: 1-770-251-2088

YOKOGAWA EUROPE B. V. (THE NETHERLANDS)

Phone: 31-334-64-1611 Facsimile: 31-334-64-1610

YOKOGAWA ENGINEERING ASIA PTE. LTD. (SINGAPORE)

Phone: 65-6241-9933 Facsimile: 65-6241-2606

YOKOGAWA AMERICA DO SUL S. A. (BRAZIL)

Phone: 55-11-5681-2400 Facsimile: 55-11-5681-1274

YOKOGAWA MEASURING INSTRUMENTS KOREA CORPORATION (KOREA)

Phone: 82-2-551-0660 to -0664 Facsimile: 82-2-551-0665

YOKOGAWA AUSTRALIA PTY. LTD. (AUSTRALIA)

Phone: 61-2-9805-0699 Facsimile: 61-2-9888-1844

YOKOGAWA INDIA LTD. (INDIA)

Phone: 91-80-4158-6000 Facsimile: 91-80-2852-1441

YOKOGAWA SHANGHAI TRADING CO., LTD. (CHINA)

Phone: 86-21-6880-8107 Facsimile: 86-21-6880-4987

YOKOGAWA MIDDLE EAST E. C. (BAHRAIN)

Phone: 973-358100 Facsimile: 973-336100

LTD. YOKOGAWA ELECTRIC (RUSSIAN FEDERATION)

Phone: 7-095-737-7868 Facsimile: 7-095-737-7869