

Contents

F3BU04-0N, F3BU06-0N, F3BU05-0D, F3BU09-0N, F3BU13-0N, F3BU16-0N	Base Modules	3
F3PU10-0S, F3PU20-0S, F3PU30-0S, F3PU16-0N, F3PU26-0N, F3PU36-0S	Power Supply Modules.....	5
F3SP22-0S	Sequence CPU Module	9
F3SP66-4S	Sequence CPU Module (with network functions)	11
F3SP67-6S	Sequence CPU Module (with network functions)	13
F3SP71-4S	Sequence CPU Module (with network functions)	15
F3SP76-7S	Sequence CPU Module (with network functions)	17
F3BP20-0N	BASIC CPU Module	19
F3BP30-0N	BASIC CPU Module	21
RK10, RK30	ROM Packs	23
RK33, RK53, RK73, RK93	ROM Packs	25

Blank Page

General Specifications

F3BU04-0N, F3BU06-0N, F3BU05-0D, F3BU09-0N, F3BU13-0N, F3BU16-0N Base Modules

FA-M3

General

FA-M3 base modules serve as the base for accommodating various modules. FA-M3 base modules are available in 4-, 5-, 6-, 9-, 13- and 16-slot versions. Choose an appropriate base module according to the target system requirements. There are no differences between main units and sub-units.

Specifications

	F3BU04-0N	F3BU06-0N	F3BU05-0D	F3BU09-0N	F3BU13-0N	F3BU16-0N
Number of slots	4	6	5	9	13	16
Number of I/O slots*	3	5	4	8	12	15
Current consumption	50mA (5V DC)					
Weight (g)	150g	210g	210g	340g	470g	550g

*: Number of I/O slots that can be used with a single CPU module.

Environment Specifications

Item	Specifications
Surrounding air temperature range	Operating : 0 to 55°C
	Storage : -20°C to 75°C
Surrounding humidity range	Operating : 10 to 90% RH (non-condensing)
	Storage : 10 to 90% RH (non-condensing)
Surrounding atmosphere	Must be free of corrosive gases, flammable gases or heavy dust.

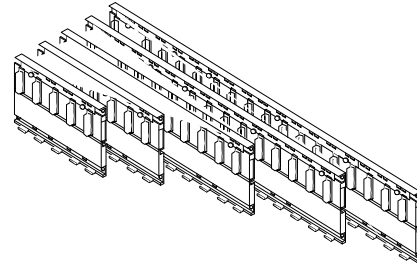

Model and Suffix Codes

Model	Suffix Code	Style Code	Option Code	Description
F3BU04	-0N	—	—	4 slots (excluding slots for power supply)
F3BU06	-0N	—	—	6 slots (excluding slots for power supply)
F3BU05	-0D	—	—	5 slots (excluding slots for power supply)
F3BU09	-0N	—	—	9 slots (excluding slots for power supply)
F3BU13	-0N	—	—	13 slots (excluding slots for power supply)
F3BU16	-0N	—	—	16 slots (excluding slots for power supply)

External Dimensions

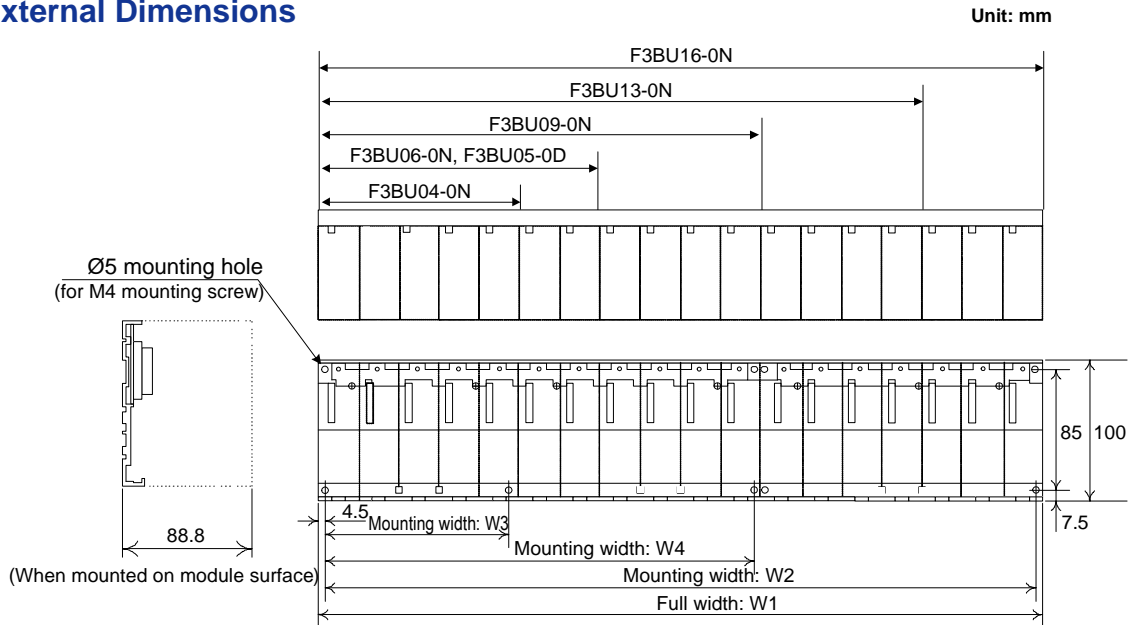

Base Modules	Full width W1	Mounting width		
		W2	W3	W4
F3BU04-0N	147	138	—	—
F3BU06-0N	205	196	—	—
F3BU05-0D	205	196	—	—
F3BU09-0N	322	313	138	—
F3BU13-0N	439	430	196	—
F3BU16-0N	527	517	138	313

Note:

- Make sure that the total current consumption of the modules to be installed does not exceed the current capacity of the power supply module.
- The F3BU16-0N module cannot be mounted on a DIN rail.
- The signal ground of the main unit is attached to the metal chassis of the base modules.

General Specifications

F3PU10-0S, F3PU20-0S, F3PU30-0S, F3PU16-0N, F3PU26-0N and F3PU36-0S Power Supply Modules

■ General

FA-M3 power supply modules supply power to the FA-M3 Range-free Multi-controllers. One power supply module is required for each FA-M3 base module.

The F3PU10-0S and F3PU16-0S are used for the F3BU04-0N and F3BU06-0N base modules. The F3PU20-0S, F3PU26-0N, F3PU30-0S and F3PU36-0□ are used for the F3BU05-0D, F3BU09-0N, F3BU13-0N and F3BU16-0N base modules.

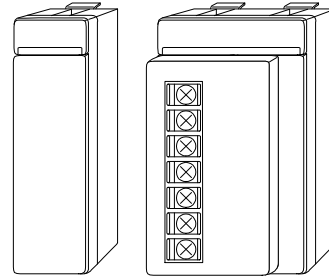

■ Specifications

Item	Specifications					
	F3PU10-0S	F3PU20-0S	F3PU30-0S	F3PU16-0N	F3PU26-0N	F3PU36-0S
Supply voltage	100-240 V AC, single phase, 50/60 Hz			24 V DC		
Supply voltage fluctuation range	85-264 V AC, 50/60 Hz \pm 3 Hz			15.6-31.2 V DC		
Power consumption	35 VA	85 VA	100 VA	15.4 W	33.1 W	46.2 W
Inrush current	20 A max. (120 V AC, Ta=25°C) 45 A max. (240 V AC, Ta=25°C)			20A max. (31.2 V DC, Ta=25°C)		
Rated output voltage	5 V DC					
Rated output current	2.0 A	4.3 A	6.0 A	2.0 A	4.3 A	6.0 A
Insulation resistance	500 V DC 5 M Ω or more between external AC terminals and FG terminal			500 V DC 5 M Ω or more between external DC terminals and FG terminal		
Dielectric strength	1500 V AC for 1 minute between external AC terminals and FG terminal			1500 V AC for 1 minute between external DC terminals and FG terminal		
Allowable momentary power failure time	20 ms					
Noise immunity	Noise level: 1500 Vp-p when measured by a noise simulator having a 1 μ s of noise pulse width, 1 ns of rise time, and 25 Hz to 60 Hz of repetition frequency.					
External dimensions *1	28.9(W) x 100(H) x 83.2(D) mm	58(W) x 100(H) x 83.2(D) mm	58(W) x 100(H) x 126.1(D) mm	28.9(W) x 100(H) x 83.2(D) mm	58(W) x 100(H) x 83.2(D) mm	58(W) x 100(H) x 126.1(D) mm
Weight	190g	320g	380g	190g	320g	380g

*1: Excluding protrusions (see external dimensions for details).

■ Environment Specifications

Item	Specifications
Surrounding air temperature range	Operating : 0 to 55°C
	Storage : -20°C to 75°C
Surrounding humidity range	Operating : 10 to 90% RH (non-condensing)
	Storage : 10 to 90% RH (non-condensing)
Surrounding atmosphere	Must be free of corrosive gases, flammable gases or heavy dust.

■ Components and Functions

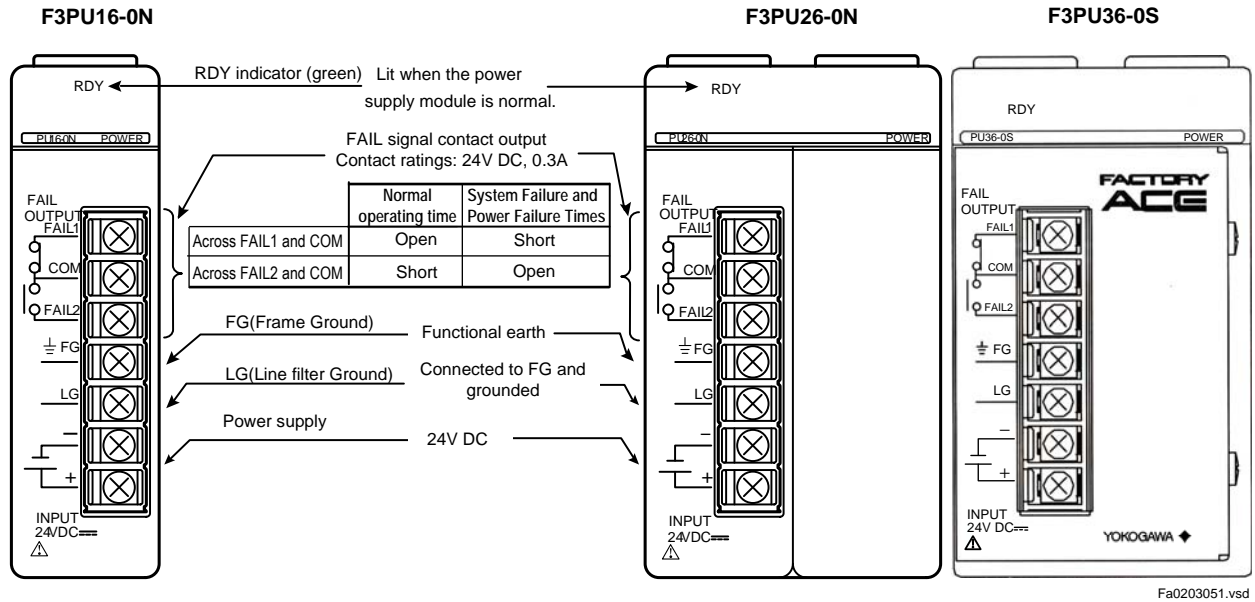
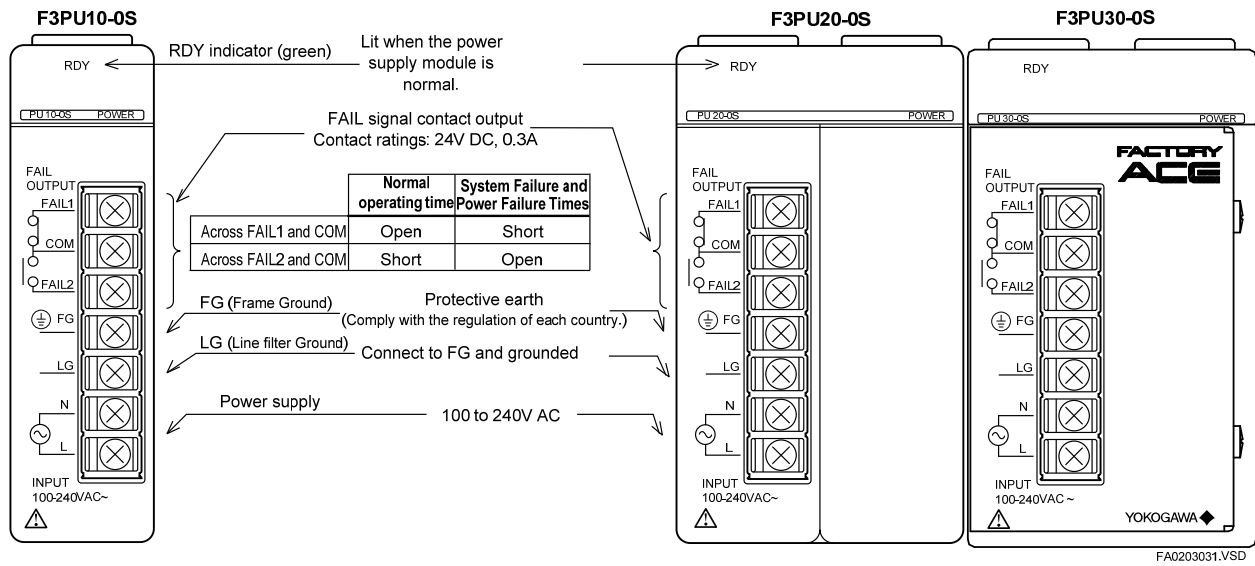

Terminal Dimensions

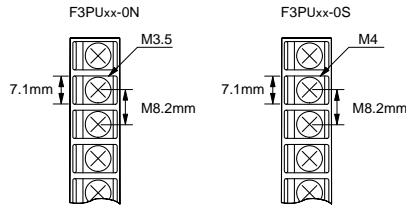

Examples of Applicable Solderless Terminals

Vender	Model	Applicable Conductor	Applicable Modules and Crimping Torque	
			F3PUx-0N	F3PUx-0S
Japan Solderless Terminal Mfg. Co., Ltd.	V1.25-M3	AWG22 to 18 (0.33 to 0.82 mm ²) (Copper wire)	0.8N · m	May not be used
Nippon Tanshi Co., Ltd.	RAV1.25-3.5			
Japan Solderless Terminal Mfg. Co., Ltd.	V1.25-M4	AWG16 to 14 (1.25 to 2.0 mm ²) (Copper wire)	0.8N · m	1.2N · m
Japan Solderless Terminal Mfg. Co., Ltd.	V2-M4			

Model and Suffix Codes

Model	Suffix Code	Style Code	Option Code	Description
F3PU10	-0S	-	-	100-240 V AC, for 4- and 6-slot base modules (M4 screws)
F3PU20	-0S	-	-	100-240 V AC, for 5-, 9-, 13-, and 16-slot base modules (M4 screws)
F3PU30	-0S	-	-	100-120 V AC, for 5-, 9-, 13-, and 16-slot base modules (M4 screws)
F3PU16	-0N	-	-	24 V DC, for 4- and 6-slot base modules (M3.5 screws)
F3PU26	-0N	-	-	24 V DC, for 5-, 9-, 13-, and 16-slot base modules (M3.5 screws)
F3PU36	-0S	-	-	24 V DC, for 5-, 9-, 13-, and 16-slot base modules (M4 screws)

External Dimensions (1/2)

Unit: mm

F3PU10-0S, F3PU16-0N

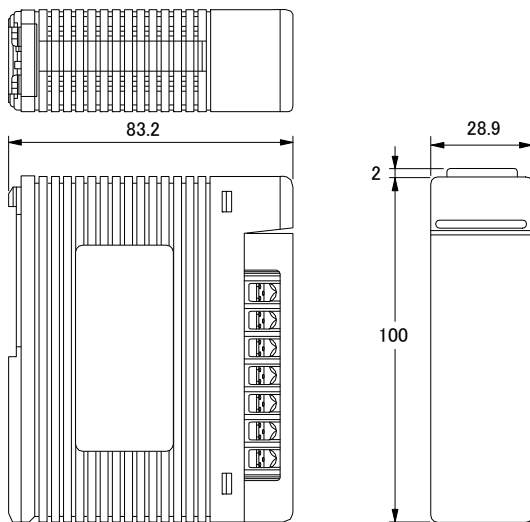

F3PU20-0S, F3PU26-0N

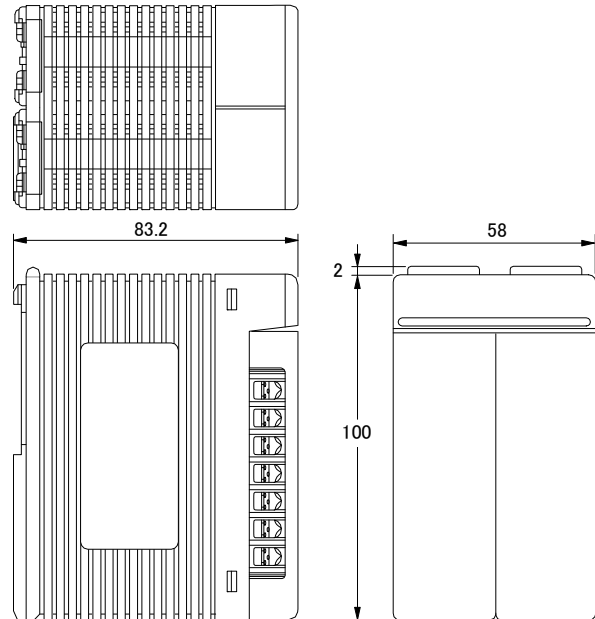

External Dimensions (2/2)

Unit: mm

F3PU30-0S, F3PU36-0S

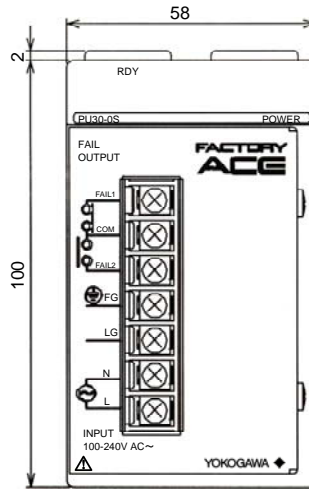
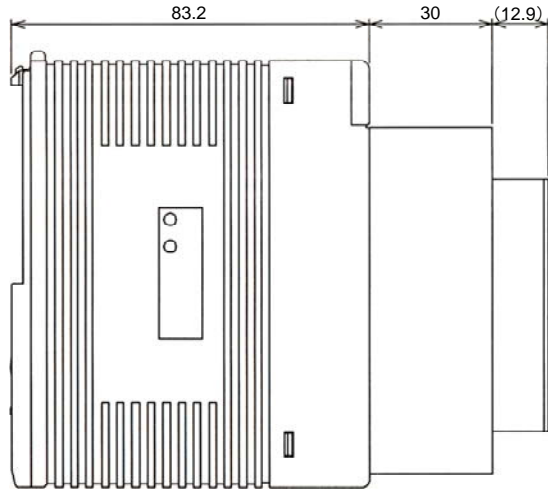
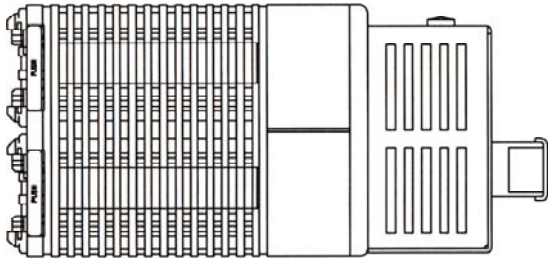

F3PU30-0S

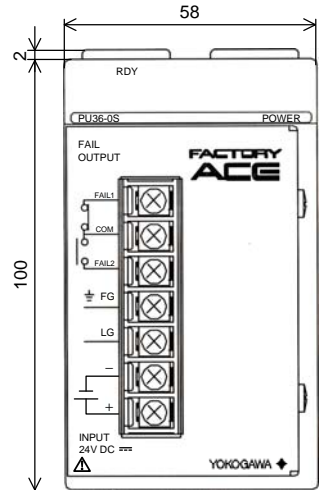

F3PU36-0S

General Specifications

F3SP22-0S Sequence CPU Module

■ General

The F3SP22-0S is a CPU module for the FA-M3 Range-free Multi-controllers.

It is a CPU module dedicated to process ladder sequences.

■ Features

- The basic instructions achieve a processing speed of 0.045 μ s and beyond.
- The high-speed instruction processing capability of the F3SP22-0S makes it ideal for applications that require high speed and quick response. (Scan time is 1ms for 6 K steps of program.) (Application instructions, such as analog I/O that read from and write to advanced modules can achieve a speed of 40 μ s and beyond.)
- The sensor control function allows one CPU to perform another scan (input, program execution and output) besides the main scan simultaneously, realizing a steady I/O response of 400 μ s.
- The use of index modification and an object ladder language simplifies program design and maintenance.
- The module permits reconfiguration of device size and operating mode according to the application in use.
- A user can create and register new instructions.
- Program debugging and maintenance can be easily performed using a rich set of functions such as forced set/reset that takes effect regardless of the result of program execution.
- Sampling trace features are provided that can collect and display the status of multiple devices with a maximum of 1024 scans.
- The programming tool link port is provided with a personal computer link feature, which allows the F3SP22-0S to connect to a higher-level computer or display without a personal computer link module.
(The maximum communication speed is 115 Kbps)
- High-reliability design and powerful self-diagnostics are provided.
Errors detected during program execution can be logged with predefined messages.
- Program data is saved to memory, which is backed up with a battery that has a long service life and does not require maintenance.
- Programs and data can be made resident in an optional ROM pack, which facilitates program modularization.
- Programs can be protected using a protection feature. This can prevent a third party from viewing, modifying or copying programs.
- When installed in slot 2, 3 or 4, the F3SP22-0S functions as an add-on sequence CPU module.
- Structures allow a user to easily reuse data.
- Circuit comments, subcomments, tag name definitions (including I/O comment) can be saved in the CPU program area, improving maintenance efficiency.
- Indirect designation and input macro instructions facilitates standardization and modularization of programs.
- The partial download function improves debugging efficiency.



■ Specifications

Item	Specifications	
Control Mode	Stored program, repetitive operation	
I/O Control Mode	Refreshing method/direct I/O instructions	
Programming Language	Object ladder language, mnemonic language	
Number of Instructions	Basic Instructions	37 types
	Application Instructions	324 types
Processing Speed	Basic Instructions	0.045 μ s to 0.18 μ s per instruction
	Application Instructions	0.18 μ s min. per instruction
Program Size	10K steps (Can be written to ROM) (including tag name definitions)	
Maximum Number of I/O	4096 points	
Device Size	Internal Relay	16384 points (16 K)
	Data Register	16384 points (16 K)
	File Register	32768 points (32 K)
Self Diagnostics	Memory error, CPU error and I/O error detection; syntax checking, etc.	
Other Features	Sensor Control Function (Scan time: 200 μ s to 25 ms) Configuration Functions (setting device sizes, output on error as well as data lock-up range at power failure) Constant scan function (1 ms to 190 ms) Debugging functions (Forced Set/Reset, online editing, etc.) Error history function (64 records) Date and clock function (year/month/day/hour/minute/second/day of week) Program protection functions Write programs and data to ROM Save functions for circuit comments, subcomments and tag name definitions	
Current Consumption	450 mA (5 V DC)	
External Dimensions	28.9 (W) \times 100 (H) \times 83.2 (D) mm*	
Weight	125 g	
Surrounding air temperature range	Operating	: 0 to 55°C
	Storage	: -20°C to 75°C
Surrounding humidity range	Operating	: 10 to 90% RH (non-condensing)
	Storage	: 10 to 90% RH (non-condensing)
Surrounding atmosphere	Must be free of corrosive gases, flammable gases or heavy dust.	

*: Excluding protrusions (see external dimensions for details).

■ Components and Functions

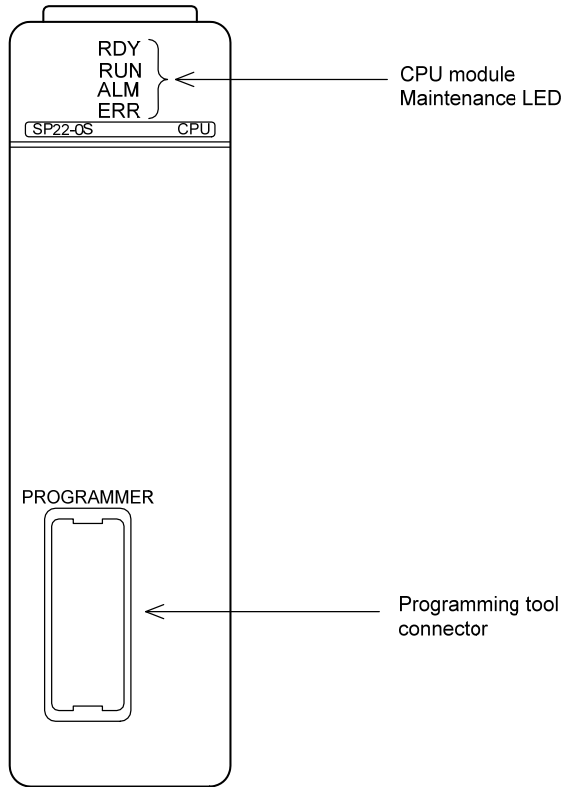

*: For information on the number of insertions/removals allowed for CPU port cables, see GS34M06C91-01E.

■ Error Processing

Errors of different severity levels are indicated by individual LEDs located on the front panel of the CPU module.

LED	Meaning
RDY (READY) Green	★ Major (When off): The hardware cannot run. Examples: CPU error Memory error
RUN (RUN) Green	When lit: A user program is running.
ALM (ALARM) Yellow	★ Minor (When lit): An error has occurred but the user program can still run. Examples: Power failure Communications error
ERR (ERROR) Red	★ Moderate (when lit): The user program cannot start or continue execution. Examples: Program error I/O comparison error* I/O module error* Memory error Sequence processor error Instruction processing error* Scan timeout*

*: You can define the severity of these events as “moderate” or “minor” (alarm) in the configuration setup.

■ Model and Suffix Codes

Model	Suffix Code	Style Code	Option Code	Description
F3SP22	-0S	—	—	Memory: 10K steps

■ External Dimensions

Unit: mm

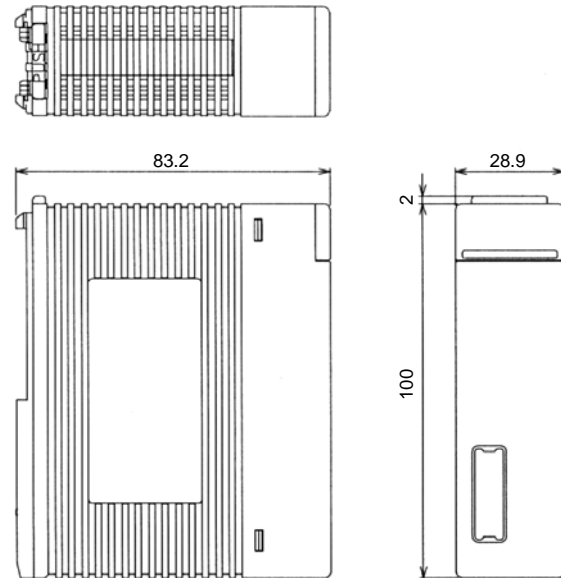

■ Operating Environment

This module is compatible with all main CPU module types when used as an add-on CPU.

This module is compatible with the following versions of the FA-M3 Programming tool WideField3.

FA-M3 programming tool WideField3	Compatible Versions
SF630-MCW	R2.01 or later

General Specifications

F3SP66-4S Sequence CPU Module (with network functions)

FA-M3

■ General

The F3SP66-4S is a sequence CPU module with built-in network functions for use with the FA-M3 Range-free Multi-controllers. In addition to a rich set of functions, which support high-speed large-data sequence processing with improved development and maintenance efficiency, the F3SP66-4S also incorporates a RAM disk, an SD memory card slot, and a 10BASE-T/100BASE-TX connector for large-volume data handling and networking.

■ Features

- The basic instructions achieve a processing speed as high as 0.0175 μ s.
- The high-speed instruction processing capability makes it ideal for applications that require high speed and quick response. (Scan time is 1 ms for 20 K steps of program.) (Analog I/O and other application instructions that access advanced function modules can achieve processing speed of 25 μ s.)
- The sensor control function allows one CPU to perform another scan (input, program execution and output) besides the main scan simultaneously, realizing a steady I/O response of 400 μ s.
- The use of index modification and an object ladder language simplifies program design and maintenance.
- The built-in 100BASE-TX Ethernet communication capability ensures high-throughput communication processing.
- A variety of network protocols are provided to support TCP/IP and UDP/IP socket communication, FTP client, FTP server, higher-level link service, remote programming and other network functions.
- Virtual directory commands are provided as extended FTP server functions to allow automatic loading of a data file into devices using the FTP put command and retrieval of device data as a data file using the FTP get command, as well as loading of programs, saving of programs and switching to RUN mode using FTP commands.
- An SD memory card can be used for storing programs and data (1GB max.). It adopts the standard PC FAT16 format so data on the card can be accessed from a PC without special software.
- A 4MB RAM disk is provided for faster file processing.
- New functions using the rotary switch located on the front panel of the module enable loading and saving of programs and other maintenance operations without using a PC.
- Card batch file functions enable program execution or device data retrieval to be automatically triggered by SD memory card insertion, an error, program execution or some other event.
- Constant definition and M3 escape sequence can be used with the FA-M3 programming tools WideField2 and WideField3. These features simplify definition of strings and contiguous byte data, as well as reuse of constants. In addition, mixed text and binary data can be defined.
- Socket communication, FTP client, file edit, file operation and many other types of new instructions are added to improve visibility, reduce code size and increase programming efficiency over the conventional relay-register interface.



■ Specifications

Item		Specifications
Control Mode		Stored program, repetitive operation
I/O Control Mode		Refreshing method/direct I/O instructions
Programming Language		Object ladder language
Number of Instructions	Basic Instructions	37 types
	Application Instructions	389 types
Processing speed	Basic Instructions	0.0175-0.07 μ s per instruction
	Application Instructions	0.07 μ s per instruction
Program Size		56K steps
Program + Tag Name Definition + Constant Definition		112K steps max.
Maximum Number of I/Os		4096 points
Device Size	Internal Relay	16384 points (16K)
	Data Register	16384 points (16K)
	File Register	32768 points
Communication Ports		USB1.1, SIO (RS-232C), Ethernet
Memory Card Slot		SD memory card
Self Diagnostics		Memory error, CPU error, I/O error detection, syntax checking, etc.
Other Features		Sensor control, configuration (device sizes, data lock-up range at power failure, error-time output, etc.), constant scan (1-190 ms), debugging (Forced set/reset, online edit, etc.), error log, user log, clock (year/month/date/hour/minute/second/day), higher-level (PC) link service, program protection, CPU properties (for communication setup, etc.), partial download, constant definition, M3 escape sequence, smart access, card batch file, card boot, SD memory card slot, RAM disk, built-in Ethernet, TCP/IP and UDP/IP socket communication, FTP client/server, virtual directory, network filter, function removal/disable, and user LED
Current Consumption		850 mA (at 5 V DC)
External Dimensions		28.9 (W) x 100 (H) x 113.2 (D) mm*
Weight		220 g
Surrounding air temperature range	Operating	: 0 to 55°C
	Storage	: -20°C to 75°C
Surrounding humidity range	Operating	: 10 to 90% RH (non-condensing)
	Storage	: 10 to 90% RH (non-condensing)
Surrounding atmosphere		Must be free of corrosive gases, flammable gases or heavy dust.

* Excluding protrusions (see external dimensions for details).

■ Components and Functions

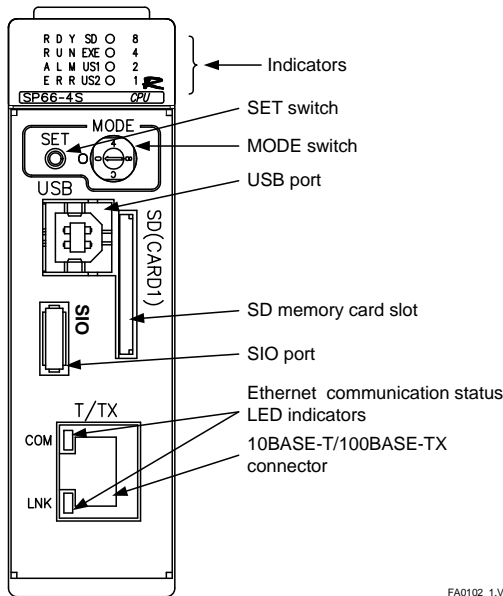

FA0102_1.VSD

■ Error Processing

Errors of different severity levels are indicated by individual LEDs located on the front panel of the CPU module.

LED	Meaning
RDY (READY) Green	★ Major (When off): The hardware cannot run. Examples: CPU error Memory error
RUN (RUN) Green	When lit: A user program is running. When blinking: Shutdown is in progress
ALM (ALARM) Yellow	★ Minor (When lit): An error has occurred but the user program can still run. Examples: Power problem Communications error
ERR (ERROR) Red	★ Moderate (when lit): The user program cannot start or continue execution Examples: Program error I/O comparison error* I/O module error* Memory error Sequence processor error Instruction processing error* Scan timeout*

* You can define the severity of these events as "moderate" or "minor" (alarm) in the configuration setup.

■ SD Memory Card Status

This LED indicates the SD memory card status.

LED	Color	Meaning	
SD	Green	Lit	Card is mounted.
		Blinking	Card is being accessed.
		Not lit	No card is mounted.

■ Smart Access Status

This LED indicates the status of smart access functions.

LED	Color	Meaning	
EXE	Green	Lit	Smart access function is running.
		Blinking	Smart access detected an error.
		Not lit	Smart access is not running.

■ User LEDs

These LEDs are controlled by a user program.

LED	Color	Meaning	
US1	Green	Lit	As defined by a user program.
		Not lit	
US2	Green	Lit	As defined by a user program.
		Not lit	

■ MODE Switch Status

These LEDs indicate the current position (value) of the MODE switch (rotary switch).

LED	Color	Meaning
8	Green	These individual LEDs mean a value of 8, 4, 2, or 1 when they are lit. The position or value (hexadecimal) of the MODE switch is indicated by the sum of these values.
4		
2		
1		

■ Model and Suffix Codes

Model	Suffix Code	Style Code	Option Code	Description
F3SP66	-4S	—	—	Memory: 56K steps With network functions

■ External Dimensions

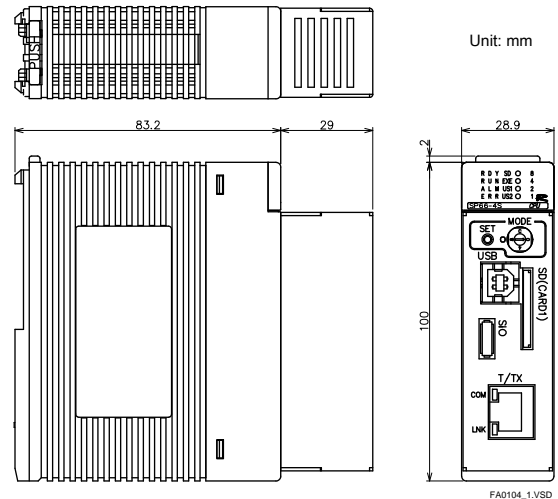

Unit: mm

FA0104_1.VSD

■ Operating Environment

This module is compatible with all main CPU module types when used as an add-on CPU.

This module is compatible with the following versions of the FA-M3 programming tools WideField2 and WideField3.

FA-M3 programming tool WideField2	Compatible Versions
SF620-MCW	R5.01 or later
SF620-ECW	R5.03 or later

FA-M3 programming tool WideField3	Compatible Versions
SF630-MCW	R2.01 or later

General Specifications

F3SP67-6S Sequence CPU Module (with network functions)

FA-M3

■ General

The F3SP67-6S is a sequence CPU module with built-in network functions for use with the FA-M3 Range-free Multi-controllers. In addition to a rich set of functions, which support high-speed large-data sequence processing with improved development and maintenance efficiency, the F3SP67-6S also incorporates a RAM disk, an SD memory card slot, and a 10BASE-T/100BASE-TX connector for large-volume data handling and networking.

■ Features

- The basic instructions achieve a processing speed as high as 0.0175 μ s.
- The high-speed instruction processing capability makes it ideal for applications that require high speed and quick response. (Scan time is 1 ms for 20 K steps of program.) (Analog I/O and other application instructions that access advanced function modules can achieve processing speed of 25 μ s.)
- The sensor control function allows one CPU to perform another scan (input, program execution and output) besides the main scan simultaneously, realizing a steady I/O response of 400 μ s.
- The use of index modification and an object ladder language simplifies program design and maintenance.
- The built-in 100BASE-TX Ethernet communication capability ensures high-throughput communication processing.
- A variety of network protocols are provided to support TCP/IP and UDP/IP socket communication, FTP client, FTP server, higher-level link service, remote programming and other network functions.
- Virtual directory commands are provided as extended FTP server functions to allow automatic loading of a data file into devices using the FTP put command and retrieval of device data as a data file using the FTP get command, as well as loading of programs, saving of programs and switching to RUN mode using FTP commands.
- An SD memory card can be used for storing programs and data (1GB max.). It adopts the standard PC FAT16 format so data on the card can be accessed from a PC without special software.
- A 4MB RAM disk is provided for faster file processing.
- New functions using the rotary switch located on the front panel of the module enable loading and saving of programs and other maintenance operations without using a PC.
- Card batch file functions enable program execution or device data retrieval to be automatically triggered by SD memory card insertion, an error, program execution or some other event.
- Constant definition and M3 escape sequence can be used with the FA-M3 programming tools WideField2 and WideField3. These features simplify definition of strings and contiguous byte data, as well as reuse of constants. In addition, mixed text and binary data can be defined.
- Socket communication, FTP client, file edit, file operation and many other types of new instructions are added to improve visibility, reduce code size and increase programming efficiency over the conventional relay-register interface.



■ Specifications

Item	Specifications	
Control Mode	Stored program, repetitive operation	
I/O Control Mode	Refreshing method/direct I/O instructions	
Programming Language	Object ladder language	
Number of Instructions	Basic Instructions	37 types
	Application Instructions	389 types
Processing speed	Basic Instructions	0.0175-0.07 μ s per instruction
	Application Instructions	0.07 μ s per instruction
Program Size	120K steps	
Program + Tag Name Definition + Constant Definition	240K steps max.	
Maximum Number of I/Os	8192 points (including remote I/O)	
Device Size	Internal Relay	32768 points (32K)
	Data Register	32768 points (32K)
	File Register	262144 points(256K)
Communication Ports	USB1.1, SIO (RS-232C), Ethernet	
Memory Card Slot	SD memory card	
Self Diagnostics	Memory error, CPU error, I/O error detection, syntax checking, etc.	
Other Features	Sensor control, configuration (device sizes, data lock-up range at power failure, error-time output, etc.), constant scan (1-190 ms), debugging (Forced set/reset, online edit, etc.), error log, user log, clock (year/month/date/hour/minute /second/day), higher-level (PC) link service, program protection, CPU properties (for communication setup, etc.), partial download, constant definition, M3 escape sequence, smart access, card batch file, card boot, SD memory card slot, RAM disk, built-in Ethernet, TCP/IP and UDP/IP socket communication, FTP client/server, virtual directory, network filter, function removal(disable), and user LED	
Current Consumption	850 mA (at 5 V DC)	
External Dimensions	28.9 (W) x 100 (H) x 113.2 (D) mm*	
Weight	220 g	
Surrounding air temperature range	Operating	: 0 to 55°C
	Storage	: -20°C to 75°C
Surrounding humidity range	Operating	: 10 to 90% RH (non-condensing)
	Storage	: 10 to 90% RH (non-condensing)
Surrounding atmosphere	Must be free of corrosive gases, flammable gases or heavy dust.	

* Excluding protrusions (see external dimensions for details).

■ Components and Functions

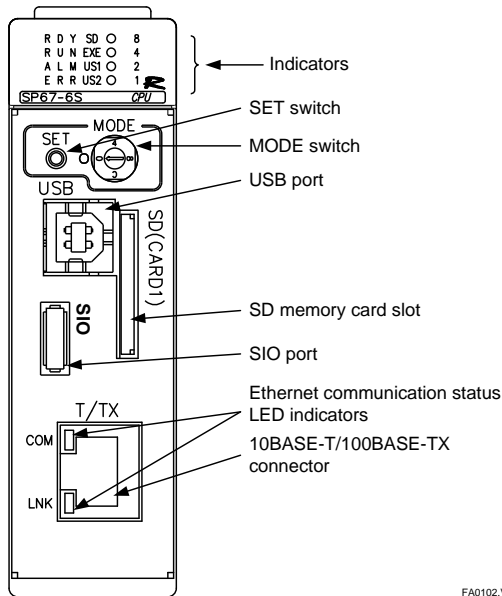

■ Error Processing

Errors of different severity levels are indicated by individual LEDs located on the front panel of the CPU module.

LED	Meaning
RDY (READY) Green	★ Major (When off): The hardware cannot run. Examples: CPU error Memory error
RUN (RUN) Green	When lit: A user program is running. When blinking: Shutdown is in progress
ALM (ALARM) Yellow	★ Minor (When lit): An error has occurred but the user program can still run. Examples: Power problem Communications error
ERR (ERROR) Red	★ Moderate (when lit): The user program cannot start or continue execution Examples: Program error I/O comparison error* I/O module error* Memory error Sequence processor error Instruction processing error* Scan timeout*

* You can define the severity of these events as "moderate" or "minor" (alarm) in the configuration setup.

■ SD Memory Card Status

This LED indicates the SD memory card status.

LED	Color	Meaning	
SD	Green	Lit	Card is mounted.
		Blinking	Card is being accessed.
		Not lit	No card is mounted.

■ Smart Access Status

This LED indicates the status of smart access functions.

LED	Color	Meaning	
EXE	Green	Lit	Smart access function is running.
		Blinking	Smart access detected an error.
		Not lit	Smart access is not running.

■ User LEDs

These LEDs are controlled by a user program.

LED	Color	Meaning	
US1	Green	Lit	As defined by a user program.
		Not lit	
US2	Green	Lit	As defined by a user program.
		Not lit	

■ MODE Switch Status

These LEDs indicate the current position (value) of the MODE switch (rotary switch).

LED	Color	Meaning
8	Green	These individual LEDs mean a value of 8, 4, 2, or 1 when they are lit. The position or value (hexadecimal) of the MODE switch is indicated by the sum of these values.
4		
2		
1		

■ Model and Suffix Codes

Model	Suffix Code	Style Code	Option Code	Description
F3SP67	-6S	—	—	Memory: 120K steps With network functions

■ External Dimensions

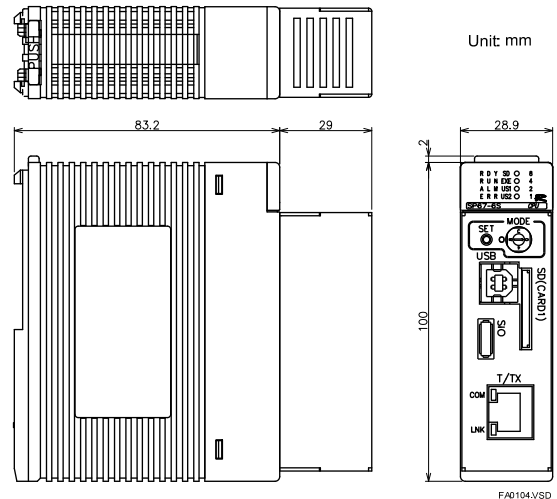

■ Operating Environment

This module is compatible with all main CPU module types when used as an add-on CPU.

This module is compatible with the following versions of the FA-M3 programming tools WideField2 and WideField3.

FA-M3 programming tool WideField2	Compatible Versions
SF620-MCW	R5.01 or later
SF620-ECW	R5.03 or later

FA-M3 programming tool WideField3	Compatible Versions
SF630-MCW	R2.01 or later

General Specifications

F3SP71-4S Sequence CPU Module (with network functions)

FA-M3

■ General

The F3SP71-4S is a sequence CPU module with built-in network functions for use with the FA-M3 Range-free Multi-controllers. In addition to a rich set of functions, which support high-speed large-data sequence processing with improved development and maintenance efficiency, the F3SP71-4S also incorporates a RAM disk, an SD memory card slot, and a 10BASE-T/100BASE-TX connector for large-volume data handling and networking.

■ Features

- The basic instructions achieve a processing speed as high as 0.00375 μ s.
- The high-speed instruction processing capability makes it ideal for applications that require high speed and quick response. (Scan time is 1 ms for 100 K steps of program.) (Analog I/O and other application instructions that access advanced function modules can achieve processing speed of 15 μ s.)
- Double-word (64-bit) integer and double-precision floating point instructions enable high-precision computations and control.
- The sensor control function allows one CPU to perform another scan (input, program execution and output) besides the main scan simultaneously, realizing a steady I/O response of 200 μ s.
- The use of index modification and an object ladder language simplifies program design and maintenance.
- The scripting function of the Ladder Programming Tool WideField3 can be used to simplify coding of text and computational processing for greater programming efficiency and visibility.
- Volatile cache registers simplify large data access.
- The built-in 100BASE-TX Ethernet communication capability ensures high-throughput communication processing.
- A variety of network protocols are provided to support TCP/IP and UDP/IP socket communication, FTP client, FTP server, high-level link service, Modbus/TCP slave (server), remote programming, etc.
- Virtual directory, an extended FTP server function, can be used to load device data by putting a data file, get device data as a data file, load, programs, save programs and change operating mode, all using FTP.
- An SD memory card can be used for storing programs and data (32GB max.). It adopts the standard PC FAT16/32 format so its data can be accessed from a PC without special software.
- A 4MB RAM disk is built-in for faster file processing.
- New functions using the rotary switch located on the front panel of the module enable loading and saving of programs and other maintenance operations without using a PC.
- Card batch file functions enable program loading or device data retrieval by simply inserting an SD memory card.
- Constant definition and M3 escape sequence can be used with the FA-M3 Programming Tool WideField3 to simplify definition of string and contiguous byte data, as well as reuse of constants.
- Socket communication, FTP client, file edit, file operation and many other types of new instructions are added to improve visibility, reduce code size and increase programming efficiency over the conventional relay-register interface.
- With advanced sampling trace, up to 1 MB device status data can be collected for debugging purposes.
- User authentication, user permissions and CPU operation restrictions prevent misoperation and improve system security.
- Operation log records when and what operations have been performed on the CPU to facilitate maintenance.



■ Specifications

Item	Specifications	
Control Mode	Stored program, repetitive operation	
I/O Control Mode	Refreshing method/direct I/O instructions	
Programming Language	Object ladder language	
Number of Instructions	Basic Instructions	40 types
	Application Instructions	445 types
Processing speed	Basic Instructions	0.00375 μ s per instruction
	Application Instructions	0.0075 μ s per instruction
Program Size	60K steps	
Project Size	120K steps max.	
Maximum Number of I/Os	4096 points	
Device Size	Internal Relay	16384 points (16K)
	Data Register	16384 points (16K)
	File Register	32768 points (32K)
	Cache Register	131072 points (128K)
Communication Ports	USB2.0 (12 Mbps), Ethernet	
Memory Card Slot	SD memory card (SDHC compatible)	
Self Diagnostics	Memory error, CPU error, I/O error detection, syntax checking, etc.	
Other Features	Sensor control, configuration (device sizes, error-time output, etc.), constant scan (1.0-190 ms), debugging (Forced set/reset, online edit, etc.), error log, user log, operation log, clock (year/month/date/hour/minute /second/day), high-level (personal computer) link service, Modbus/TCP slave (server), program protection, CPU properties (for communication setup, etc.), constant definition, smart access, card batch file, card boot, RAM disk, built-in Ethernet, TCP/IP and UDP/IP socket communication, FTP client/server, virtual directory, network filter, user LED, advanced sampling trace, user authentication, user permissions and CPU operation restrictions	
Current Consumption	460 mA (at 5 V DC)	
External Dimensions	28.9 (W) x 100 (H) x 83.2 (D) mm*	
Weight	120 g	
Surrounding air temperature range	Operating	: 0 to 55°C
	Storage	: -20°C to 75°C
Surrounding humidity range	Operating	: 10 to 90% RH (non-condensing)
	Storage	: 10 to 90% RH (non-condensing)
Surrounding atmosphere	Must be free of corrosive gases, flammable gases or heavy dust.	

* Excluding protrusions (see external dimensions for details.)

■ Components and Functions

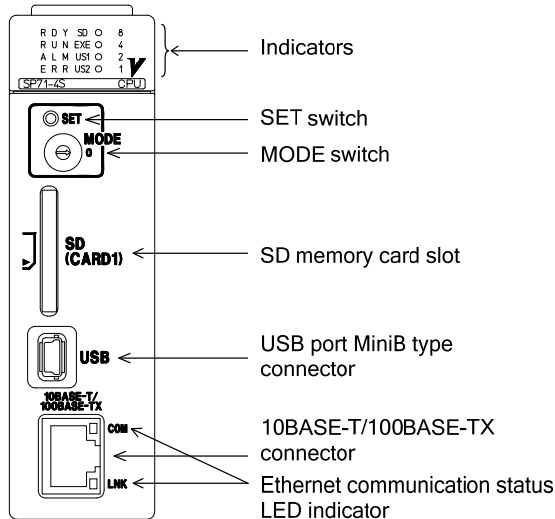

■ Error Processing

Errors of different severity levels are indicated by individual LEDs located on the front panel of the CPU module.

LED	Meaning
RDY (READY) Green	★ Major (When off): The hardware cannot run. Examples: CPU error Memory error
RUN (RUN) Green	When lit: A user program is running. When blinking: Shutdown is in progress
ALM (ALARM) Yellow	★ Minor (When lit): An error has occurred but the user program can still run. Examples: Power problem Communications error
ERR (ERROR) Red	★ Moderate (when lit): The user program cannot start or continue execution Examples: Program error I/O comparison error* I/O module error* Memory error Sequence processor error Instruction processing error* Scan timeout*

* You can define the severity of these events as "moderate" or "minor" (alarm) in the configuration setup.

■ SD Memory Card Status

This LED indicates the SD memory card status.

LED	Color	Meaning	
SD	Green	Lit	Card is mounted.
		Blinking	Card is being accessed.
		Not lit	No card is mounted.

■ Smart Access Status

This LED indicates the status of smart access functions.

LED	Color	Meaning	
EXE	Green	Lit	Smart access function is running.
		Blinking	Smart access detected an error.
		Not lit	Smart access is not running.

■ User LEDs

These LEDs are controlled by a user program.

LED	Color	Meaning	
US1	Green	Lit	As defined by a user program.
		Not lit	
US2	Green	Lit	As defined by a user program.
		Not lit	

■ MODE Switch Status

These LEDs indicate the current position (value) of the MODE switch (rotary switch).

LED	Color	Meaning
8	Green	These individual LEDs mean a value of 8, 4, 2, or 1 when they are lit. The position or value (hexadecimal) of the MODE switch is indicated by the sum of these values.
4		
2		
1		

■ Model and Suffix Codes

Model	Suffix Code	Style Code	Option Code	Description
F3SP71	-4S	—	—	Memory: 60K steps With network functions Modbus/TCP slave (server) function

■ External Dimensions

Unit: mm

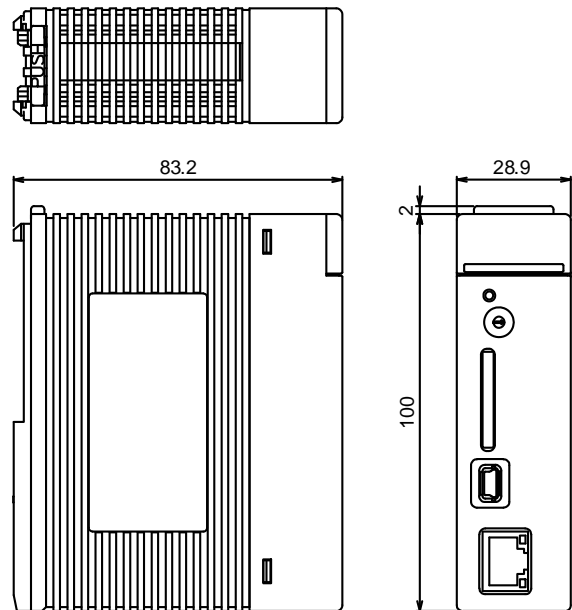

■ Operating Environment

This module is compatible with all main CPU module types when used as an add-on CPU.

This module is compatible with the following versions of the FA-M3 Programming Tool WideField3.

FA-M3 Programming Tool WideField3	Compatible Versions
SF630-MCW	R2.01 or later

General Specifications

F3SP76-7S Sequence CPU Module (with network functions)

FA-M3

■ General

The F3SP76-7S is a sequence CPU module with built-in network functions for use with the FA-M3 Range-free Multi-controllers. In addition to a rich set of functions, which support high-speed large-data sequence processing with improved development and maintenance efficiency, the F3SP76-7S also incorporates a RAM disk, an SD memory card slot, and a 10BASE-T/100BASE-TX connector for large-volume data handling and networking.

■ Features

- The basic instructions achieve a processing speed as high as 0.00375 μ s.
- The high-speed instruction processing capability makes it ideal for applications that require high speed and quick response. (Scan time is 1 ms for 100 K steps of program.) (Analog I/O and other application instructions that access advanced function modules can achieve processing speed of 15 μ s.)
- Double-word (64-bit) integer and double-precision floating point instructions enable high-precision computations and control.
- The sensor control function allows one CPU to perform another scan (input, program execution and output) besides the main scan simultaneously, realizing a steady I/O response of 200 μ s.
- The use of index modification and an object ladder language simplifies program design and maintenance.
- The scripting function of the Ladder Programming Tool WideField3 can be used to simplify coding of text and computational processing for greater programming efficiency and visibility.
- Volatile cache registers simplify large data access.
- The built-in 100BASE-TX Ethernet communication capability ensures high-throughput communication processing.
- A variety of network protocols are provided to support TCP/IP and UDP/IP socket communication, FTP client, FTP server, high-level link service, Modbus/TCP slave (server), remote programming, etc.
- Virtual directory, an extended FTP server function, can be used to load device data by putting a data file, get device data as a data file, load, programs, save programs and change operating mode, all using FTP.
- An SD memory card can be used for storing programs and data (32GB max.). It adopts the standard PC FAT16/32 format so its data can be accessed from a PC without special software.
- A 4MB RAM disk is built-in for faster file processing.
- New functions using the rotary switch located on the front panel of the module enable loading and saving of programs and other maintenance operations without using a PC.
- Card batch file functions enable program loading or device data retrieval by simply inserting an SD memory card.
- Constant definition and M3 escape sequence can be used with the FA-M3 Programming Tool WideField3 to simplify definition of string and contiguous byte data, as well as reuse of constants.
- Socket communication, FTP client, file edit, file operation and many other types of new instructions are added to improve visibility, reduce code size and increase programming efficiency over the conventional relay-register interface.
- With advanced sampling trace, up to 1 MB device status data can be collected for debugging purposes.
- User authentication, user permissions and CPU operation restrictions prevent misoperation and improve system security.
- Operation log records when and what operations have been performed on the CPU to facilitate maintenance.



■ Specifications

Item	Specifications	
Control Mode	Stored program, repetitive operation	
I/O Control Mode	Refreshing method/direct I/O instructions	
Programming Language	Object ladder language	
Number of Instructions	Basic Instructions	40 types
	Application Instructions	445 types
Processing speed	Basic Instructions	0.00375 μ s per instruction
	Application Instructions	0.0075 μ s per instruction
Program Size	260K steps	
Project Size	520K steps max.	
Maximum Number of I/Os	8192 points (including remote I/O)	
Device Size	Internal Relay	65535 points (64K)
	Data Register	65535 points (64K)
	File Register	262144 points (256K)
	Cache Register	524288 points (512K)
Communication Ports	USB2.0 (12 Mbps), Ethernet	
Memory Card Slot	SD memory card (SDHC compatible)	
Self Diagnostics	Memory error, CPU error, I/O error detection, syntax checking, etc.	
Other Features	Sensor control, configuration (device sizes, error-time output, etc.), constant scan (1.0-190 ms), debugging (Forced set/reset, online edit, etc.), error log, user log, operation log, clock (year/month/date/hour/minute /second/day), high-level (personal computer) link service, Modbus/TCP slave (server), program protection, CPU properties (for communication setup, etc.), constant definition, smart access, card batch file, card boot, RAM disk, built-in Ethernet, TCP/IP and UDP/IP socket communication, FTP client/server, virtual directory, network filter, user LED, advanced sampling trace, user authentication, user permissions and CPU operation restrictions	
Current Consumption	460 mA (at 5 V DC)	
External Dimensions	28.9 (W) x 100 (H) x 83.2 (D) mm*	
Weight	120 g	
Surrounding air temperature range	Operating	: 0 to 55°C
	Storage	: -20°C to 75°C
Surrounding humidity range	Operating	: 10 to 90% RH (non-condensing)
	Storage	: 10 to 90% RH (non-condensing)
Surrounding atmosphere	Must be free of corrosive gases, flammable gases or heavy dust.	

* Excluding protrusions (see external dimensions for details.)

■ Components and Functions

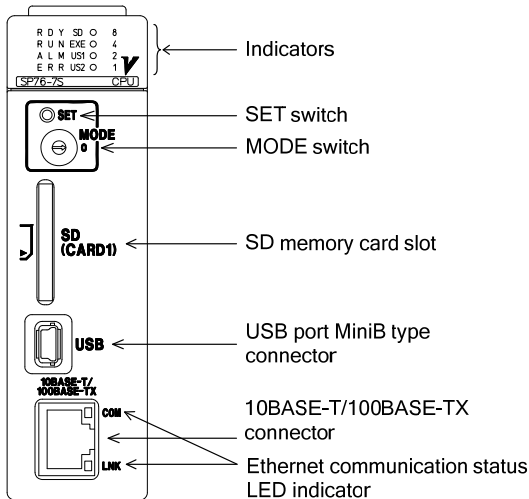

■ Error Processing

Errors of different severity levels are indicated by individual LEDs located on the front panel of the CPU module.

LED	Meaning
RDY (READY) Green	★ Major (When off): The hardware cannot run. Examples: CPU error Memory error
RUN (RUN) Green	When lit: A user program is running. When blinking: Shutdown is in progress
ALM (ALARM) Yellow	★ Minor (When lit): An error has occurred but the user program can still run. Examples: Power problem Communications error
ERR (ERROR) Red	★ Moderate (when lit): The user program cannot start or continue execution Examples: Program error I/O comparison error* I/O module error* Memory error Sequence processor error Instruction processing error* Scan timeout*

* You can define the severity of these events as "moderate" or "minor" (alarm) in the configuration setup.

■ SD Memory Card Status

This LED indicates the SD memory card status.

LED	Color	Meaning	
SD	Green	Lit	Card is mounted.
		Blinking	Card is being accessed.
		Not lit	No card is mounted.

■ Smart Access Status

This LED indicates the status of smart access functions.

LED	Color	Meaning	
EXE	Green	Lit	Smart access function is running.
		Blinking	Smart access detected an error.
		Not lit	Smart access is not running.

■ User LEDs

These LEDs are controlled by a user program.

LED	Color	Meaning	
US1	Green	Lit	As defined by a user program.
		Not lit	
US2	Green	Lit	As defined by a user program.
		Not lit	

■ MODE Switch Status

These LEDs indicate the current position (value) of the MODE switch (rotary switch).

LED	Color	Meaning
8	Green	These individual LEDs mean a value of 8, 4, 2, or 1 when they are lit. The position or value (hexadecimal) of the MODE switch is indicated by the sum of these values.
4		
2		
1		

■ Model and Suffix Codes

Model	Suffix Code	Style Code	Option Code	Description
F3SP76	-7S	—	—	Memory: 260K steps With network functions Modbus/TCP slave (server) function

■ External Dimensions

Unit: mm

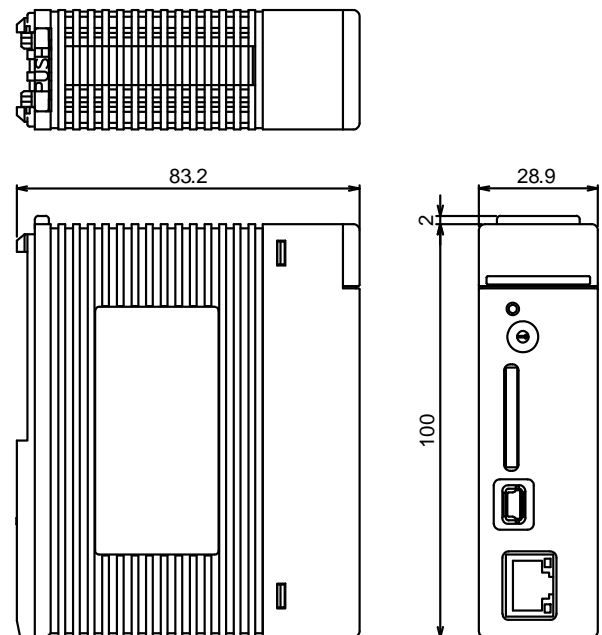

■ Operating Environment

This module is compatible with all main CPU module types when used as an add-on CPU.

This module is compatible with the following versions of the FA-M3 Programming Tool WideField3.

FA-M3 Programming Tool WideField3	Compatible Versions
SF630-MCW	R2.01 or later

General Specifications

F3BP20-0N BASIC CPU Module

FA-M3

General

The F3BP20 BASIC CPU Module adopts high-speed real-time BASIC (YM-BASIC/FA) established for the FA500 and YEWMAC series, and is used in a wide range of communications and information processing applications.

Features

- The F3BP20 is ideal for applications where communications modules that cannot be controlled with ladder sequence programs or sophisticated computations are required.
- The F3BP20 can be installed in any one of slots 1 to 4 of the main unit. It can run without a sequence CPU module, thereby configuring a BASIC controller.
- It can access I/O modules directly.
- Exchanging data with ladder sequence programs is available. The operation can be synchronized with ladder sequence programs via events.
- It allows structured programming using subprograms.
- It can access common data via a personal computer link module.
- It can store programs and common data, as well as perform ROM-based operation using an optional ROM pack.
- It allows programming and debugging on a general-purpose personal computer.

Specifications

Item	Specifications
Programming Language	YM-BASIC/FA
Type	Interpreter (with pre-run feature)
Number of Tasks	1
Program Size	120 K bytes
Shared Device	Shared register (R): 1024 points max. (Shared relays and extended shared relays or registers cannot be used.)
Self-diagnostics	Memory error, CPU error, power failure, etc.
Other Features	Configuration functions (setting size of user and common areas, etc.) Program residency function Error history function Program development and debugging functions Date and clock function (year/month/day/hour/minute/second/day of week) Accessing (read/write) common data via a personal computer link module ROM programming and data storage
Maximum Number of Modules	1 module per unit
Current Consumption	200 mA (5V DC)
External Dimensions	28.9 (W) × 100 (H) × 83.2 (D) mm*
Weight	105 g

*: Excluding protrusions (see external dimensions for details).

Environment Specifications

Item	Specifications
Surrounding air temperature range	Operating : 0 to 55°C
	Storage : -20°C to 75°C
Surrounding humidity range	Operating : 10 to 90% RH (non-condensing)
	Storage : 10 to 90% RH (non-condensing)
Surrounding atmosphere	Must be free of corrosive gases, flammable gases or heavy dust.

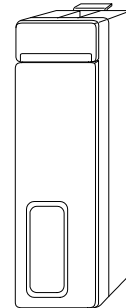

Components and Functions

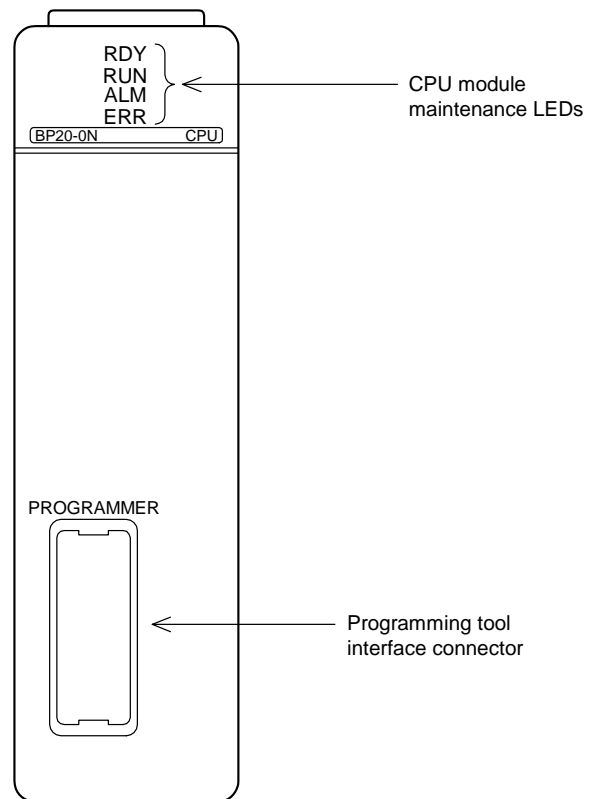

*: For information on the number of insertions/removals allowed for CPU port cables, see GS34M06C91-01E.

■ Error Processing

Errors of different severity levels are indicated by individual LEDs located on the front panel of the CPU module.

LED	Meaning
RDY (READY) Green	★ Major (When off): The hardware cannot run. Examples: CPU error Memory error
RUN (RUN) Green	When lit: A user program is running.
ALM (ALARM) Yellow	★ Minor (When lit): An error has occurred but the user program can still run. Examples: Power failure I/O module error Communications error ★ Debugging mode: The CPU module is in the debugging mode (lit when it is connected to a personal computer and program development and debugging are in progress).
ERR (ERROR) Red	★ Moderate (when lit): The user program cannot start or continue execution. Examples: Program error I/O module error Instruction processing error

■ Model and Suffix Codes

Model	Suffix Code	Style Code	Option Code	Description
F3BP20	-0N	—	—	Memory: 120K steps

■ External Dimensions

Unit: mm

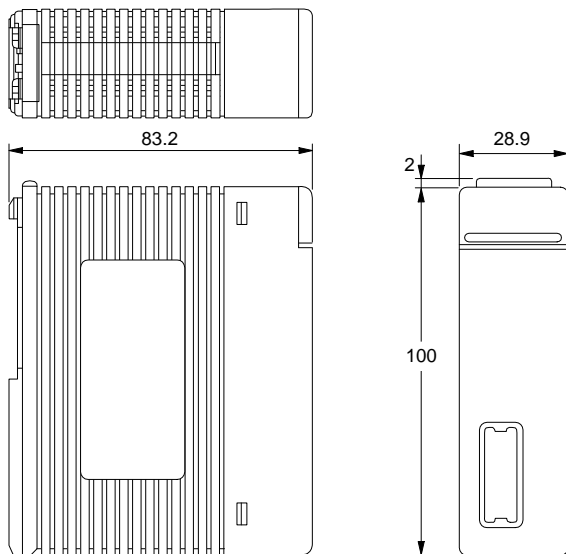

■ Operating Environment

- The table below lists the CPU modules that are compatible with this module.

CPU Module	Applicable Revision Number
F3SP21-0N, F3SP22-0S, F3SP25-2N, F3SP28-3x, F3SP35-5N, F3SP38-6x, F3SP53-4x, F3SP58-6x, F3SP59-7S, F3SP66-4S, F3SP67-6S, F3SP71-4x, F3SP76-7x	No restriction on revision number
F3FP36-3N	No restriction on revision number

Note: This module cannot be used as an add-on BASIC CPU to the F3SP05-0P and F3SP08-0P sequence CPU module used for the FA-M3 Value and FA-M3 Value2 (See GS 34M06C81-01E).

- The table below lists the ROM packs compatible with this module.

Item	RK10-0N	RK30-0N
F3BP20-0N	Cannot be used	120K bytes

General Specifications

F3BP30-0N BASIC CPU Module

FA-M3

General

The F3BP30 BASIC CPU Module adopts high-speed real-time BASIC (YM-BASIC/FA) established for the FA500 and YEWMAC series, and is used in a wide range of communications and information processing applications.

Features

- The F3BP30 is ideal for applications where communications modules that cannot be controlled with ladder sequence programs or sophisticated computations are required.
- The F3BP30 can be installed in any one of slots 1 to 4 of the main unit. It can run without a sequence CPU module, thereby configuring a BASIC controller.
- It can access I/O modules directly.
- Exchanging data with ladder sequence programs is available. The operation can be synchronized with ladder sequence programs via events.
- It allows structured programming using subprograms.
- It can access common data via a personal computer link module.
- It can store programs and common data, as well as perform ROM-based operation using an optional ROM pack.
- It allows programming and debugging on a general-purpose personal computer.

Specifications

Item	Specifications
Programming Language	YM-BASIC/FA
Type	Interpreter (with pre-run feature)
Number of Tasks	1
Program Size	510 K bytes
Shared Device	Shared register (R): 1024 points max. (Shared relays and extended shared relays or registers cannot be used.)
Self-diagnostics	Memory error, CPU error, power failure, etc.
Other Features	Configuration functions (setting size of user and common areas, etc.) Program residency function Error history function Program development and debugging functions Date and clock function (year/month/day/hour/minute/second/day of week) Accessing (read/write) common data via a personal computer link module ROM programming and data storage
Maximum Number of modules	1 module per unit
Current Consumption	200mA (5V DC)
External Dimensions	28.9 (W) × 100 (H) × 83.2 (D) mm*
Weight	105 g

*: Excluding protrusions (see external dimensions for details).

Environment Specifications

Item	Specifications
Surrounding air temperature range	Operating : 0 to 55°C
	Storage : -20°C to 75°C
Surrounding humidity range	Operating : 10 to 90% RH (non-condensing)
	Storage : 10 to 90% RH (non-condensing)
Surrounding atmosphere	Must be free of corrosive gases, flammable gases or heavy dust.

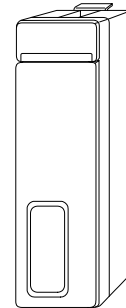

Components and Functions

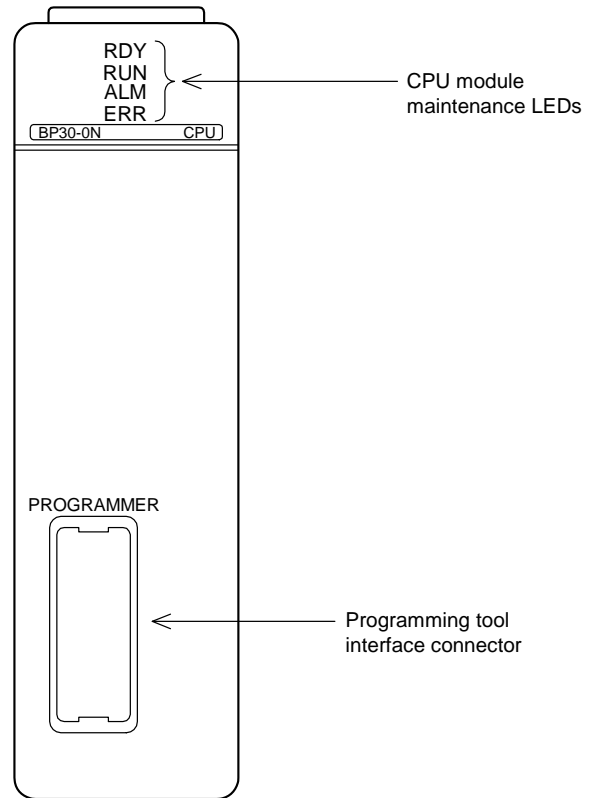

*: For information on the number of insertions/removals allowed for CPU port cables, see GS34M06C91-01E.

■ Error Processing

Errors of different severity levels are indicated by individual LEDs located on the front panel of the CPU module.

LED	Meaning
RDY (READY) Green	★ Major (When off): The hardware cannot run. Examples: CPU error Memory error
RUN (RUN) Green	When lit: A user program is running.
ALM (ALARM) Yellow	★ Minor (When lit): An error has occurred but the user program can still run. Examples: Power failure I/O module error Communications error ★ Debugging mode: The CPU module is in the debugging mode (lit when it is connected to a personal computer and program development and debugging are in progress).
ERR (ERROR) Red	★ Moderate (when lit): The user program cannot start or continue execution. Examples: Program error I/O module error Instruction processing error

■ Model and Suffix Codes

Model	Suffix Code	Style Code	Option Code	Description
F3BP30	-0N	—	—	Memory: 510K steps

■ External Dimensions

Unit: mm

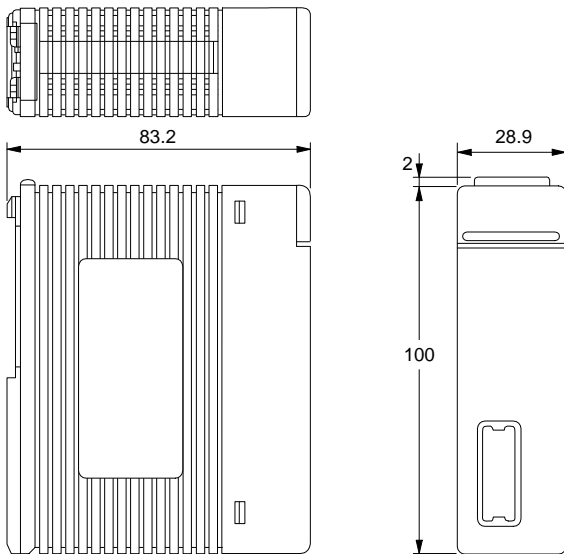

■ Operating Environment

The table below lists the CPU modules that are compatible with this module.

CPU Module	Applicable Revision Number
F3SP21-0N, F3S-22-0S, F3SP25-2N, F3SP28-3□, F3SP35-5N, F3SP38-6□, F3SP53-4□, F3SP58-6□, F3SP59-7S, F3SP66-4S, F3SP67-6S, F3SP71-4□, F3SP76-7□	No restriction on revision number
F3FP36-3N	No restriction on revision number

Note: This module cannot be used as an add-on BASIC CPU to the F3SP05-0P and F3SP08-0P sequence CPU module used for the FA-M3 Value and FA-M3 Value2 (See GS 34M06C81-01E).

The table below lists the ROM packs compatible with this module.

Item	RK10-0N	RK30-0N
F3BP30-0N	Cannot be used	Cannot be used

The table below lists the BASIC Programming Tool M3 that is compatible with the F3BP30-0N.

BASIC Programming Tool M3	Applicable Revision Number
SF560-ECW	*

*: Contact YOKOGAWA sales representatives.

General Specifications

RK10-0N, RK30-0N
ROM Packs

FA-M3

General

The RK10, RK30 ROM Packs are used with the F3SP05-0P, F3SP08-0P, F3SP20-0N, F3SP21-0N, F3SP25-2N, F3SP30-0N and F3SP35-5N Sequence CPU Modules, and the F3BP20-0N BASIC CPU Modules for the FA-M3 Range-free Multi-controller.

Features

- Programs and data can be stored in ROM packs.
- The programming tool enables programs and data to be written on the ROM packs.
- Data that can be written to the ROM pack include program-control information, programs, configurations, various control tables, tables of timer/counter preset values, and comment management information.
- The RK30-0N ROM packs can store 1024 words of data registers (for the F3SP05-0P, F3SP08-0P, F3SP20-0N, F3SP21-0N, F3SP25-2N, F3SP30-0N, and F3SP35-5N only).

Specifications

Item	RK10-0N	RK30-0N
With F3SP05-0P	5 K steps*1	5 K steps
With F3SP08-0P	5 K steps	10 K steps
With F3SP20-0N	5 K steps*1	10 K steps
With F3SP21-0N	5 K steps*1	10 K steps
With F3SP25-2N	Not available	20 K steps
With F3SP30-0N	5 K steps *1 *2	20 K steps
With F3SP35-5N	Not available	20 K steps *3 *4
With F3BP20-0N	Not available	120 K bytes *6
With F3BP30-0N	Not available	Not available

- *1: Can store up to 400 lines including circuit comments and sub comments.
- *2: Can store up to 512 data points including timers and counters.
- *3: Can store up to 2048 data points including timers and counters.
- *4: Up to 128 program blocks can be used.
- *5: Up to 80 K steps of program code can be made resident when the number of program blocks is 33 or more.
- *6: Can store up to 120 K bytes of code and data including user programs and common area data.
- *7: Can store up to 510 K bytes of code and data including user programs and common area data.

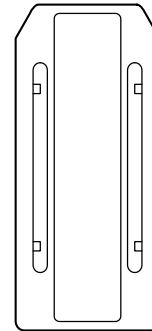

External Dimensions

Unit: mm

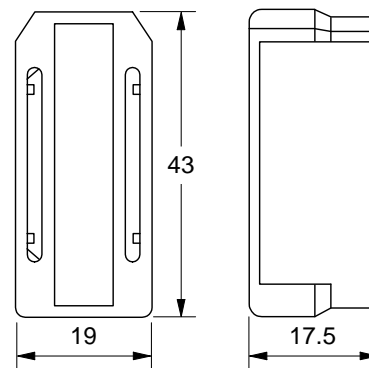
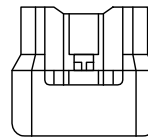

Model and Suffix Codes

Model	Suffix Code	Style Code	Option Code	Description
RK10	-0N	—	—	5 K steps when a sequence CPU module is used.
RK30	-0N	—	—	20 K steps when a sequence CPU module is used. 120 K bytes of user program code and common area data when a BASIC CPU module is used.

Note: ROM Packs cannot be used with F3SP66-4S, F3SP67-6S, F3SP71-4□ and F3SP76-7□ sequence CPU modules, which support SD memory card instead.

General Specifications

RK33-0N, RK53-0N,
RK73-0N, RK93-0N
ROM Packs

FA-M3

General

These ROM Packs are used with the F3SP05-0P, F3SP08-0P, F3SP21-0N, F3SP22-0S, F3SP25-2N, F3SP35-5N, F3SP28-3□, F3SP38-6□, F3SP53-4□, F3SP58-6□ and F3SP59-7S Sequence CPU Modules, and the F3BP30-0N BASIC CPU Module for the FA-M3 Range-free Multi-controller.

Features

- Programs and data can be stored in ROM packs.
- The programming tool enables programs and data to be written on the ROM packs.
- Data that can be written to the ROM pack include program-control information, programs, configurations, various control tables, tables of timer/counter preset values, and comment management information.
- The ROM packs can store 1024 words of data registers when a sequence CPU module is used.

Specifications

Item	RK33-0N	RK53-0N	RK73-0N	RK93-0N
With F3SP05-0P	5 K steps	5Ksteps	Not available	Not available
With F3SP08-0P	5K steps	10Ksteps	Not available	Not available
With F3SP21-0N	10Ksteps	10Ksteps	Not available	Not available
With F3SP22-0S	56Ksteps ⁹	Not available	120Ksteps ⁹	Not available
With F3SP25-2N	20Ksteps	20Ksteps	Not available	Not available
With F3SP35-5N	20Ksteps ¹	100Ksteps ²	Not available	Not available
With F3SP28-3N	30Ksteps	Not available	30Ksteps	Not available
With F3SP38-6N	56Ksteps	Not available	120Ksteps	Not available
With F3SP53-4H	56Ksteps	Not available	56Ksteps	Not available
With F3SP58-6H	56Ksteps	Not available	120Ksteps	Not available
With F3SP28-3S	56Ksteps ⁵	Not available	120Ksteps ⁵	Not available
With F3SP38-6S	56Ksteps	Not available	120Ksteps	360Ksteps ⁶
With F3SP53-4S	56Ksteps	Not available	120Ksteps ⁷	Not available
With F3SP58-6S	56Ksteps	Not available	120Ksteps	360Ksteps ⁶
With F3SP59-7S	56Ksteps	Not available	120Ksteps	360Ksteps ⁸
With F3BP20-0N ⁴	Not available	Not available	Not available	Not available
With F3BP30-0N	Not available	510K steps ³	Not available	Not available

*1: Can store up to 2048 data points including timers and counters and up to 128 program blocks.

*2: Up to 80 K steps of program code can be saved when the number of program blocks is 33 or more.

*3: Can store up to 510 K bytes of code and data including user programs and common area data.

*4: Use the RK30-0N ROM pack for the F3BP20-0P module.

*5: Can store up to 30 K steps of program.

*6: Can store up to 120 K steps of program.

*7: Can store up to 56 K steps of program.

*8: Can store up to 254K steps of program.

*9: Can store up to 10K steps of program.

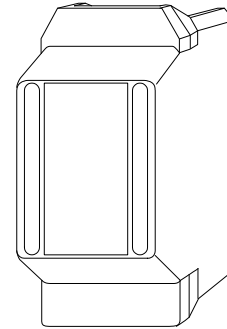

External Dimensions

Unit: mm

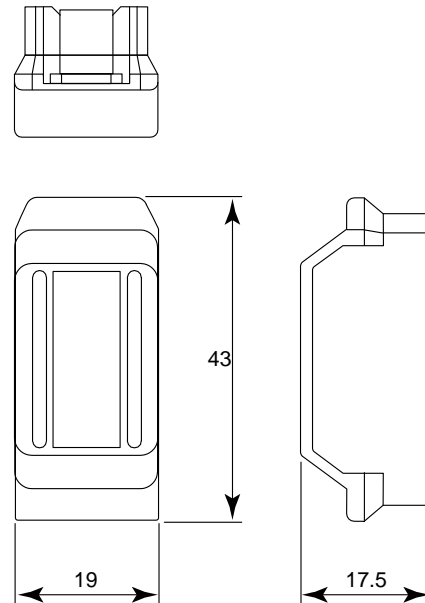

Model and Suffix Codes

Model	Suffix Code	Style Code	Option Code	Description
RK33	-0N	—	—	56 K steps when a sequence CPU module is used.
RK53	-0N	—	—	100 K steps when a sequence CPU module is used. 510 K bytes of user program code and common area data when a BASIC CPU module is used.
RK73	-0N	—	—	120 K steps when a sequence CPU module is used.
RK93	-0N	—	—	360 K steps when a sequence CPU module is used.

Note: ROM Packs cannot be used with F3SP66-4S, F3SP67-6S, F3SP71-4□ and F3SP76-7□ sequence CPU modules, which support SD memory card instead.