

# General Specifications

## EJX120A Differential Pressure Transmitter



GS 01C25B03-01E

The high performance draft range differential pressure transmitter EJX120A features single crystal silicon resonant sensor and is suitable to measure liquid, gas, or steam flow as well as liquid level, density and pressure. EJX120A outputs a 4 to 20 mA DC signal corresponding to the measured differential pressure. Its highly accurate and stable sensor can also measure the static pressure which can be shown on the integral indicator or remotely monitored via BRAIN or HART communications. Other key features include quick response, remote set-up using communications, diagnostics and optional status output for pressure high/low alarm. The multi-sensing technology provides the advanced diagnostic function to detect such abnormalities as an impulse line blockage or heat trace breakage. FOUNDATION Fieldbus protocol type is also available. All EJX series models in their standard configuration, with the exception of the Fieldbus type, are certified by TÜV as complying with SIL 2 for safety requirement.



### ■ STANDARD SPECIFICATIONS

Refer to GS 01C25T02-01E for Fieldbus communication type marked with “◇.”

#### □ SPAN AND RANGE LIMITS

Measurement Span/Range	kPa	inH <sub>2</sub> O/(D1)	mbar/(D3)	mmH <sub>2</sub> O/(D4)
E	Span 0.025 to 1 (0.1 to 1)	0.1 to 4 (0.4 to 4)	0.25 to 10 (1 to 10)	2.5 to 100 (10 to 100)
	Range -1 to 1	-4 to 4	-10 to 10	-100 to 100

( ) show the span limits for square root output.

T01E.EPS

#### □ PERFORMANCE SPECIFICATIONS

Zero-based calibrated span, linear output, wetted parts material code S and silicone oil, unless otherwise mentioned.  
For Fieldbus communication type, use calibrated range instead of span in the following specifications.

#### Specification Conformance

EJX series ensures specification conformance to at least  $\pm 3\sigma$ .

#### Reference Accuracy of Calibrated Span

(includes terminal-based linearity, hysteresis, and repeatability)

Measurement span	E
Reference accuracy	X ≤ span $\pm 0.09\%$ of Span
	X > span $\pm (0.015 + 0.03 \text{ URL}/\text{span})\%$ of Span
X	0.4 kPa (1.6 inH <sub>2</sub> O)
URL (upper range limit)	1 kPa (4 inH <sub>2</sub> O)

T08E.EPS

#### Square Root Output Accuracy

The square root accuracy is a percent of flow span.

Output	Accuracy
50% or Greater	Same as reference accuracy
50% to Dropout point	$\frac{\text{Reference accuracy} \times 50}{\text{Square root output (\%)}}$

T03E.EPS

#### Ambient Temperature Effects per 28°C (50°F) Change

$\pm (0.1\% \text{ Span} + 0.15\% \text{ URL})$

#### Power Supply Effects (Output signal code D and E)

$\pm 0.005\%$  per Volt (from 21.6 to 32 V DC, 350 Ω)

#### Vibration Effects

##### Amplifier housing code 1:

Less than 0.1% of URL when tested per the requirements of IEC60770-1 field or pipeline with high vibration level (10-60 Hz, 0.21 mm peak to peak displacement/60-2000 Hz 3 g)

##### Amplifier housing code 2:

Less than  $\pm 0.1\%$  of URL when tested per the requirements of IEC60770-1 field with general application or pipeline with low vibration level (10-60 Hz 0.15mm peak to peak displacement /60-500 Hz 2g)

#### Mounting Position Effects

Rotation in diaphragm plane has no effect. Tilting up to 90 degree will cause zero shift up to 0.4 kPa (1.6 inH<sub>2</sub>O) which can be corrected by the zero adjustment.

#### Response Time (Differential pressure) “◇”

150 msec

When amplifier damping is set to zero and including dead time of 45 msec (nominal)

□ **FUNCTIONAL SPECIFICATIONS**

**Output “◇”**

Two wire 4 to 20 mA DC output with digital communications, linear or square root programmable. BRAIN or HART FSK protocol are superimposed on the 4 to 20 mA signal.

Output range: 3.6 mA to 21.6 mA

Output limits conforming to NAMUR NE43 can be pre-set by option code C2 or C3.

**Failure Alarm (Output signal code D and E)**

Analog output status at CPU failure and hardware error;

Up-scale: 110%, 21.6 mA DC or more (standard)

Down-scale: -5%, 3.2 mA DC or less

Analog output status at process abnormality (Option code /DG6);

The result of process abnormality detected by the advanced diagnostic function can be reflected to an analog alert status. The following three setting modes are available.

		Mode		
		Burnout	Fall back	Off
Standard		110 %, 21.6mA or more	Holds to a specified value within the output range from 3.6mA to 21.6mA	Not Available (normal output)
Option Code	/C1	-2.5%, 3.6mA or less		
	/C2	-1.25%, 3.8mA or less		
	/C3	103.1%, 20.5mA or more		

T11E.EPS

**Damping Time Constant (1st order)**

Amplifier damping time constant is adjustable from 0.00 to 100.00 sec by software and added to response time.

Note: For BRAIN protocol type, when amplifier software damping is set to less than 0.5 sec, communication may occasionally be unavailable during the operation, especially while output changes dynamically. The default setting of damping ensures stable communication.

**Update Period “◇”**

Differential pressure: 45 msec

**Zero Adjustment Limits**

Zero can be fully elevated or suppressed, within the lower and upper range limits of the capsule.

**External Zero Adjustment**

External zero is continuously adjustable with 0.01% incremental resolution of span. Re-range can be done locally using the digital indicator with range-setting switch.

**Integral Indicator (LCD display, optional) “◇”**

5-digit numerical display, 6-digit unit display and bar graph.

The indicator is configurable to display one or up to four of the following variables periodically.;

Measured differential pressure, differential pressure in %, scaled differential pressure. See also “Factory Setting.”

**Self Diagnostics**

CPU failure, hardware failure, configuration error, and over-range error for differential pressure, and capsule temperature.

User-configurable process high/low alarm for differential pressure is also available, and its status can be output when optional status output is specified.

**Advanced Diagnostics (optional) “◇”**

Applicable for Output signal code E and F.

- Impulse line blockage detection

The impulse line condition can be calculated and detected by extracting the fluctuation component from the differential pressure signal.

- Heat trace monitoring

The change of the flange temperature calculated by using the two temperature sensors built in the EJX enables to detect the heat trace breakage or the abnormal temperature due to the failure.

**Signal Characterizer (Output signal code D and E)**

User-configurable 10-segment signal characterizer for 4 to 20 mA output.

**Status Output (optional, output signal code D and E)**

One transistor contact output (sink type) to output the status of user configurable high/low alarm for differential pressure.

Contact rating : 10.5 to 30 V DC, 120 mA DC max. Refer to ‘Terminal Configuration’ and ‘Wiring Example for Analog Output and Status Output.’

**SIL Certification**

EJX series transmitters except Fieldbus communication type are certified by TÜV in compliance with the following standards;

IEC 61508: 2000; Part1 to Part 7

Functional Safety of Electrical/electronic/programmable electronic related systems; SIL 2 capability for single transmitter use, SIL 3 capability for dual transmitter use.

□ **NORMAL OPERATING CONDITION**

(Optional features or approval codes may affect limits.)

**Ambient Temperature Limits**

-25 to 80°C (-13 to 176°F)

**Process Temperature Limits**

-25 to 80°C (-13 to 176°F)

**Ambient Humidity Limits**

0 to 100% RH

**Working Pressure Limits (Silicone oil)**

50 kPa (7.25 psi)

**Supply & Load Requirements**

(Output signal code D and E. Optional features or approval codes may affect electrical requirements.)

With 24 V DC supply, up to a 550 Ω load can be used. See graph below.

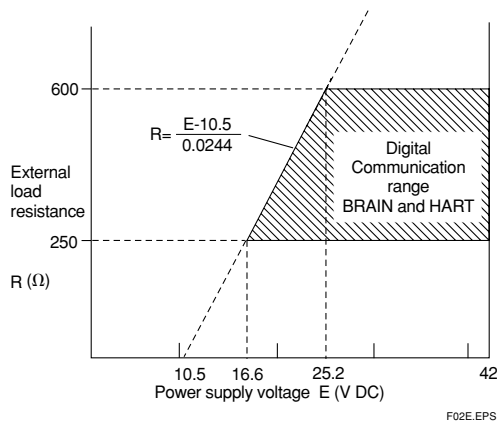

**Figure 2. Relationship Between Power Supply Voltage and External Load Resistance**

**Supply Voltage “◇”**

- 10.5 to 42 V DC for general use and flameproof type.
- 10.5 to 32 V DC for lightning protector (option code / A.)
- 10.5 to 30 V DC for intrinsically safe, type n, or non-incendive.
- Minimum voltage limited at 16.6 V DC for digital communications, BRAIN and HART

**Load (Output signal code D and E)**

- 0 to 1290 Ω for operation
- 250 to 600 Ω for digital communication

**Communication Requirements “◇”**

(Approval codes may affect electrical requirements.)

**BRAIN**

**Communication Distance**

Up to 2 km (1.25 miles) when using CEV polyethylene-insulated PVC-sheathed cables. Communication distance varies depending on type of cable used.

**Load Capacitance**

0.22 μF or less

**Load Inductance**

3.3 mH or less

**Input Impedance of communicating device**

10 kΩ or more at 2.4 kHz.

**EMC Conformity Standards** CE , N200

- EN61326-1 Class A, Table2 (For use in industrial locations)
- EN61326-2-3

**European Pressure Equipment Directive 97/23/EC**

Sound Engineering Practice (for all capsules)

**□ PHYSICAL SPECIFICATIONS**

**Wetted Parts Materials**

**Diaphragm, Cover Flange, Process Connector, Capsule Gasket, and Vent/Drain Plug**  
Refer to “MODEL AND SUFFIX CODES.”

**Process Connector Gasket**

- PTFE Teflon
- Fluorinated rubber for option code N2 and N3

**Non-wetted Parts Materials**

**Bolting**

ASTM-B7 carbon steel, 316L SST stainless steel, or ASTM grade 660 stainless steel

**Housing**

Low copper cast aluminum alloy with polyurethane, mint-green paint (Munsell 5.6BG 3.3/2.9 or its equivalent), or ASTM CF-8M Stainless Steel

**Degrees of Protection**

IP67, NEMA4X, JIS C0920

**Cover O-rings**

Buna-N

**Name plate and tag**

304 SST, 316 SST (optional)

**Fill Fluid**

Silicone, fluorinated oil (optional)

**Weight**

- [Installation code 7, 8 and 9]
- 3.7 kg (8.2 lb) without integral indicator, mounting bracket, and process connector.
- Add 1.5 kg (3.3lb) for Amplifier housing code 2.

**Connections**

- Refer to “MODEL AND SUFFIX CODES.”
- Process connection of cover flange: IEC61518

**< Related Instruments >**

- Power Distributor: Refer to GS 01B04T01-02E or GS 01B04T02-02E
- BRAIN TERMINAL: Refer to GS 01C00A11-00E

**< Reference >**

1. Teflon; Trademark of E.I. DuPont de Nemours & Co.
  2. Hastelloy; Trademark of Haynes International Inc.
  3. HART; Trademark of the HART Communication Foundation.
  4. FOUNDATION Fieldbus; Trademark of Fieldbus Foundation.
- Other company names and product names used in this material are registered trademarks or trademarks of their respective owners.

**MODEL AND SUFFIX CODES**

Model	Suffix Codes	Description
<b>EJX120A</b>	.....	Differential pressure transmitter
Output signal	-D ..... -E ..... -F .....	4 to 20 mA DC with digital communication (BRAIN protocol) 4 to 20 mA DC with digital communication (HART protocol) Digital communication (FOUNDATION Fieldbus protocol, refer to GS 01C25T02-01E)
Measurement span (capsule)	E .....	0.025 to 1 kPa (0.1 to 4 inH <sub>2</sub> O)
Wetted parts material *2	<input type="checkbox"/> .....	Refer to "Wetted Parts Material" Table below.
Process connections	0 ..... 1 ..... 2 ..... 3 ..... 4 ..... ☆ 5 .....	without process connector (Rc1/4 female on the cover flanges) with Rc1/4 female process connector with Rc1/2 female process connector with 1/4 NPT female process connector with 1/2 NPT female process connector without process connector (1/4 NPT female on the cover flanges)
Bolts and nuts material	J ..... G ..... C .....	ASTM-B7 carbon steel 316L SST stainless steel ASTM grade 660 stainless steel
Installation	☆ -7 ..... -8 ..... -9 ..... -U .....	Vertical piping, left side high pressure, and process connection downside Horizontal piping and right side high pressure Horizontal piping and left side high pressure Universal flange
Amplifier housing	1 ..... 2 .....	Cast aluminum alloy ASTM CF-8M stainless steel*3
Electrical connection	☆ 0 ..... 2 ..... 4 ..... 5 ..... 7 ..... 9 ..... A ..... C ..... D .....	G1/2 female, one electrical connection without blind plugs 1/2 NPT female, two electrical connections without blind plugs M20 female, two electrical connections without blind plugs G1/2 female, two electrical connections and a blind plug*4 1/2 NPT female, two electrical connections and a blind plug*4 M20 female, two electrical connections and a blind plug*4 G1/2 female, two electrical connections and a 316 SST blind plug 1/2 NPT female, two electrical connections and a 316 SST blind plug M20 female, two electrical connections and a 316 SST blind plug
Integral indicator	☆ D ..... E ..... N .....	Digital indicator Digital indicator with the range setting switch*1 None
Mounting bracket	☆ B ..... D ..... J ..... K ..... N .....	304 SST 2-inch pipe mounting, flat type (for horizontal piping) 304 SST 2-inch pipe mounting, L type (for vertical piping) 316 SST 2-inch pipe mounting, flat type (for horizontal piping) 316 SST 2-inch pipe mounting, L type (for vertical piping) None
Optional Codes	<input type="checkbox"/>	Optional specification

T04E.EPS

The "☆" marks indicate the most typical selection for each specification.

- \*1: Not applicable for output signal code **F**.
- \*2: ⚠ Users must consider the characteristics of selected wetted parts material and the influence of process fluids. The use of inappropriate materials can result in the leakage of corrosive process fluids and cause injury to personnel and/or damage to plant facilities. It is also possible that the diaphragm itself can be damaged and that material from the broken diaphragm and the fill fluid can contaminate the user's process fluids. Be very careful with highly corrosive process fluids such as hydrochloric acid, sulfuric acid, hydrogen sulfide, sodium hypochlorite, and high-temperature steam (150°C [302°F] or above). Contact Yokogawa for detailed information of the wetted parts material.
- \*3: Not applicable for electrical connection code **0**, **5**, **7** and **9**.
- \*4: Material of a blind plug is aluminum alloy or 304 SST.

**Table. Wetted Parts Materials**

Wetted parts material code	Cover flange and process connector	Capsule	Capsule gasket	Drain/Vent plug
S #	ASTM CF-8M *1	Hastelloy C-276 *2 (Diaphragm) 316L SST *3 (Others)	PTFE Teflon	316 SST

M04E.EPS

- \*1: Cast version of 316 SST. Equivalent to SCS14A.
- \*2: Hastelloy C-276 or ASTM N10276.
- \*3: 316L SST, F316L SST.

The '#' marks indicate the construction materials conform to NACE material recommendations per MR01-75. For the use of 316 SST material, there may be certain limitations for pressure and temperature. Please refer to NACE standards for details.

**OPTIONAL SPECIFICATIONS (For Explosion Protected type) “◇”**

Item	Description	Code
Factory Mutual (FM)	FM Explosionproof Approval *1 Applicable Standard: FM3600, FM3615, FM3810, ANSI/NEMA 250 Explosionproof for Class I, Division 1, Groups B, C and D, Dust-ignitionproof for Class II/III, Division 1, Groups E, F and G, in Hazardous locations, indoors and outdoors (NEMA 4X) Temperature class: T6, Amb. Temp.: -40 to 60°C (-40 to 140°F)	<b>FF1</b>
	FM Intrinsically safe Approval *1*2 Applicable Standard: FM3600, FM3610, FM3611, FM3810 Intrinsically Safe for Class I, Division 1, Groups A, B, C & D, Class II, Division 1, Groups E, F & G and Class III, Division 1, Class I, Zone 0, in Hazardous Locations, AEx ia IIC Nonincendive for Class I, Division 2, Groups A, B, C & D, Class II, Division. 2, Groups F & G, and Class III, Division 1, Class I, Zone 2, Group IIC, in Hazardous Locations Enclosure: "NEMA 4X", Temp. Class: T4, Amb. Temp.: -60 to 60°C (-75 to 140°F) Intrinsically Safe Apparatus Parameters [Groups A, B, C, D, E, F and G] Vmax=30 V, Imax=200 mA, Pmax=1 W, Ci=6 nF, Li=0 μH [Groups C, D, E, F and G] Vmax=30 V, Imax=225 mA, Pmax=1 W, Ci=6 nF, Li=0 μH	<b>FS1</b>
	Combined FF1 and FS1 *1*2	<b>FU1</b>
CENELEC ATEX	CENELEC ATEX (KEMA) Flameproof Approval *1 Applicable Standard: EN 60079-0, EN 60079-1, EN 61241-0, EN 61241-1 Certificate: KEMA 07ATEX0109 II 2G, 2D Exd IIC T4, T5, T6 Ex tD A21 IP6X T85, T100, T120 Degree of protection : IP66 and IP67 Amb. Temp. (Tamb) for gas-proof : T4 ; -50 to 75°C (-58 to 167°F), T5; -50 to 80°C (-58 to 176°F), T6; -50 to 75°C (-58 to 167°F) Max. process Temp.(Tp): T4; 120°C (248°F), T5; 100°C (212°F), T6; 85°C (185°F) Max. surface Temp. for dust-proof : T85°C (Tamb: -40 to 40°C, Tp:85°C), T100°C (Tamb: -40 to 60°C, Tp:100°C), T120°C (Tamb: -40 to 80°C, Tp:120°C)	<b>KF21</b>
	CENELEC ATEX (KEMA) Intrinsically safe Approval *1*2 Applicable Standard: EN 50014, EN 50020, EN 50284, EN 50281-1-1 Certificate: KEMA 03ATEX1544X II 1G, 1D EEx ia IIC T4 Degree of protection : IP66 and IP67 Amb. Temp.(Tamb) for gas-proof: -50 to 60°C (-58 to 140°F) Maximum Process Temp.(Tp) for gas-proof :120°C Electrical data : Ui=30 V, li=200 mA, Pi=0.9 W, Ci=10 nF, Li=0 mH Max. surface Temp. for dust-proof : T85°C (Tamb: -40 to 60°C, Tp:80°C), T100°C (Tamb: -40 to 60°C, Tp:100°C), T120°C (Tamb: -40 to 60°C, Tp:120°C)	<b>KS2</b>
	Combined KF21, KS2 and Type n *1*2 Type n Applicable Standard: EN 60079-15 Referential Standard: IEC60079-0, IEC60079-11 II 3G Ex nL IIC T4, Amb. Temp.: -50 to 60°C (-50 to 140°F) Ui=30 V DC, Ci=10 nF, Li=0 mH	<b>KU21</b>

T06E.EPS

\*1: Applicable for Electrical connection code **2, 4, 7, 9, C and D**.

\*2: Not applicable for option code **/AL**.

Item	Description	Code
Canadian Standards Association (CSA)	<p>CSA Explosionproof Approval *1                      Certificate: 2014354                      Applicable Standard: C22.2 No.0, C22.2 No.0.4, C22.2 No.0.5, C22.2 No.25, C22.2 No.30, C22.2 No.94, C22.2 No.60079-0, C22.2 No.60079-1, C22.2 No.61010-1-01                      Explosion-proof for Class I, Groups B, C and D.                      Dustignition-proof for Class II/III, Groups E, F and G.                      When installed in Division 2, "SEAL NOT REQUIRED" Enclosure: TYPE 4X, Temp. Code: T6...T4                      Ex d IIC T6...T4 Enclosure: IP66 and IP67                      Max.Process Temp.: T4;120°C(248°F), T5;100°C(212 °F), T6; 85°C(185°F)                      Amb.Temp.: -50 to 75°C(-58 to 167°F) for T4, -50 to 80°C(-58 to 176°F) for T5, -50 to 75°C(-58 to 167°F) for T6</p> <p>Process Sealing Certification                      Dual Seal Certified by CSA to the requirement of ANSI/ISA 12.27.01                      No additional sealing required                      Primary seal failure annunciation: at the zero adjustment screw</p>	<b>CF1</b>
	<p>CSA Intrinsically safe Approval *1*2                      Certificate: 1606623                      [For CSA C22.2]                      Applicable Standard: C22.2 No.0, C22.2 No.0.4, C22.2 No.25, C22.2 No.94, C22.2 No.154, C22.2 No.213, C22.2 No.1010.1                      Intrinsically Safe for Class I, Division 1, Groups A, B, C &amp; D, Class II, Division 1, Groups E, F &amp; G, Class III, Division 1, Nonincendive for Class I, Division 2, Groups A, B, C &amp; D, Class II, Division 2, Groups E, F &amp; G, Class III, Division 1                      Enclosure: Type 4X, Temp. Code: T4 Amb. Temp.: -50 to 60°C(-58 to 140°F)                      Electrical Parameters: [Intrinsically Safe] Vmax=30V, Imax=200mA, Pmax=0.9W, Ci=10nF, Li=0                      [Nonincendive] Vmax=30V, Ci=10nF, Li=0</p> <p>[For CSA E60079]                      Applicable Standard: CAN/CSA E60079-0, CAN/CSA E60079-11, CAN/CSA E60079-15, IEC 60529:2001-02                      Ex ia IIC T4, Ex nL IIC T4 Enclosure: IP66 and IP67                      Amb. Temp.: -50 to 60°C(-58 to 140°F), Max. Process Temp.: 120°C(248°F)                      Electrical Parameters: [Ex ia] Ui=30V, li=200mA, Pi=0.9W, Ci=10nF, Li=0                      [Ex nL] Ui=30V, Ci=10nF, Li=0</p> <p>Process Sealing Certification                      Dual Seal Certified by CSA to the requirement of ANSI/ISA 12.27.01                      No additional sealing required                      Primary seal failure annunciation: at the zero adjustment screw</p>	<b>CS1</b>
	Combined CF1 and CS1 *1*2	<b>CU1</b>
IECEX Scheme *3	<p>IECEX Flameproof Approval *1                      Applicable Standard: IEC 60079-0:2004, IEC60079-1:2003                      Certificate: IECEX CSA 07.0008                      Flameproof for Zone 1, Ex d IIC T6...T4 Enclosure: IP66 and IP67                      Max.Process Temp.: T4;120°C(248°F), T5;100°C(212°F), T6; 85°C(185°F)                      Amb.Temp.: -50 to 75°C(-58 to 167°F) for T4, -50 to 80°C(-58 to 176°F) for T5, -50 to 75°C(-58 to 167°F) for T6</p>	<b>SF2</b>
	<p>IECEX Intrinsically safe, type n and Flameproof Approval *1*2                      Intrinsically safe and type n                      Applicable Standard: IEC 60079-0:2000, IEC 60079-11:1999, IEC 60079-15:2001                      Certificate: IECEX CSA 05.0005                      Ex ia IIC T4, Ex nL IIC T4 Enclosure: IP66 and IP67                      Amb. Temp.: -50 to 60°C(-58 to 140°F), Max. Process Temp.: 120°C(248°F)                      Electrical Parameters: [Ex ia] Ui=30V, li=200mA, Pi=0.9W, Ci=10nF, Li=0                      [Ex nL] Ui=30V, Ci=10nF, Li=0</p> <p>Flameproof                      Applicable Standard: IEC 60079-0:2004, IEC60079-1:2003                      Certificate: IECEX CSA 07.0008                      Flameproof for Zone 1, Ex d IIC T6...T4 Enclosure: IP66 and IP67                      Max.Process Temp.: T4;120°C(248°F), T5;100°C(212°F), T6; 85°C(185°F)                      Amb.Temp.: -50 to 75°C(-58 to 167°F) for T4, -50 to 80°C(-58 to 176°F) for T5, -50 to 75°C(-58 to 167°F) for T6</p>	<b>SU2</b>
Combination of approval	Combination of KU21, FU1 and CU1 *1*2	<b>V1U</b>

\*1: Applicable for Electrical connection code **2, 4, 7, 9, C** and **D**.  
 \*2: Not applicable for option code **/AL**.  
 \*3: Applicable only for Australia, New Zealand, Singapore and India.

T05Eb.EPS

## OPTIONAL SPECIFICATIONS

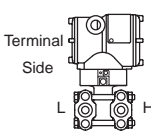
Item	Description		Code
Painting	Color change	Amplifier cover only*9	P□
		Amplifier cover and terminal cover, Munsell 7.5 R4/14	PR
	Coating change	Anti-corrosion coating*1*9	X2
316 SST exterior parts	316 SST nameplate, tag plate and zero adjustment screw*10		HC
Lightning protector	Transmitter power supply voltage: 10.5 to 32 V DC ( 10.5 to 30 V DC for intrinsically safe type.) Allowable current: Max. 6000 A ( 1×40 μs ), Repeating 1000 A ( 1×40 μs ) 100 times Applicable Standards: IEC 61000-4-4, IEC 61000-4-5		A
Status output*2	Transistor output (sink type) Contact rating : 10.5 to 30 V DC, 120 mA DC(max) Low level : 0 to 2 V DC		AL
Oil-prohibited use*3	Degrease cleansing treatment		K1
	Degrease cleansing treatment and fluorinated oilfilled capsule. Operating temperature -20 to 80°C( -4 to 176°F)		K2
Oil-prohibited use with dehydrating treatment*3	Degrease cleansing and dehydrating treatment		K5
	Degrease cleansing and dehydrating treatment with fluorinated oilfilled capsule. Operating temperature -20 to 80°C( -4 to 176°F)		K6
Capsule fill fluid	Fluorinated oil filled in capsule Operating temperature -20 to 80°C( -4 to 176°F)		K3
Calibration units*4	P calibration (psi unit)	(See Table for Span and Range Limits.)	D1
	bar calibration (bar unit)		D3
	M calibration (kgf/cm <sup>2</sup> unit)		D4
Long vent*5	Total length: 119 mm (standard: 34 mm); Total length when combining with option code K1, K2, K5, and K6: 130 mm. Material: 316 SST		U1
Output limits and failure operation*6	Failure alarm down-scale : Output status at CPU failure and hardware error is -5%, 3.2mA DC or less.		C1
	NAMUR NE43 Compliant Output signal limits : 3.8 mA to 20.5 mA	Failure alarm down-scale : Output status at CPU failure and hardware error is -5%, 3.2 mA DC or less.	C2
		Failure alarm up-scale : Output status at CPU failure and hardware error is 110%, 21.6 mA or more.	C3
Body option*7		Right side high pressure, without drain and vent plugs	N1
		N1 and Process connection, based on IEC61518 with female thread on both sides of cover flange, with blind kidney flanges on back.	N2
		N2, and Material certificate for cover flange, diaphragm, capsule body, and blind kidney flange	N3
Wired tag plate	304 SST tag plate wired onto transmitter (316 SST when /HC is specified)		N4
Data configuration at factory*8	Data configuration for HART communication type	Software damping, Descriptor, Message	CA
	Data configuration for BRAIN communication type	Software damping	CB
Advanced diagnostics*11	Multi-sensing process monitoring • Impulse line blockage detection*12 • Heat trace monitoring		DG6

T06E.EPS

- \*1: Not applicable with color change option.
- \*2: Check terminals cannot be used when this option code is specified. Not applicable for output signal code **F** and amplifier housing code **2**.
- \*3: Applicable for Wetted parts material code **S**.
- \*4: The unit of MWP (Max. working pressure) on the name plate of a housing is the same unit as specified by option codes **D1**, **D3**, and **D4**.
- \*5: Applicable for vertical impulse piping type (Installation code **7**) and Wetted parts material code **S**.
- \*6: Applicable for output signal codes **D** and **E**. The hardware error indicates faulty amplifier or capsule.
- \*7: Applicable for wetted parts material code **S**; process connection codes **3**, **4**, and **5**; installation code **9**; and mounting bracket code **N**. Process connection faces on the other side of zero adjustment screw.
- \*8: Also see 'Ordering Information'.
- \*9: Not applicable for amplifier housing code **2**.
- \*10: 316 or 316L SST. The specification is included in amplifier housing code **2**.
- \*11: Applicable only for output signal code **-E**.
- \*12: The change of pressure fluctuation is monitored and then detects the impulse line blockage. See TI 01C25A31-01E for detailed technical information required for using this function. The detection is for one side only.

Item	Description	Code	
Material certificate*1	Cover flange *2	<b>M01</b>	
	Cover flange, Process connector *3	<b>M11</b>	
Pressure test/ Leak test certificate*4	Test Pressure: 50 kPa (7.25 psi)	Nitrogen(N <sub>2</sub> ) Gas*5	<b>T04</b>
		Retention time: one minute	

T06Eb.EPS

\*1: Material traceability certification, per EN 10204 3.1B.

\*2: Applicable for process connections codes **0** and **5**.

\*3: Applicable for process connections codes **1**, **2**, **3**, and **4**.

\*4: The unit on the certificate is always Pa unit regardless of selection of option code **D1**, **D3** or **D4**.

\*5: Pure nitrogen gas is used for oil-prohibited use (option codes **K1**, **K2**, **K5**, and **K6**).

## DIMENSIONS

### ● Vertical Impulse Piping Type (INSTALLATION CODE '7')

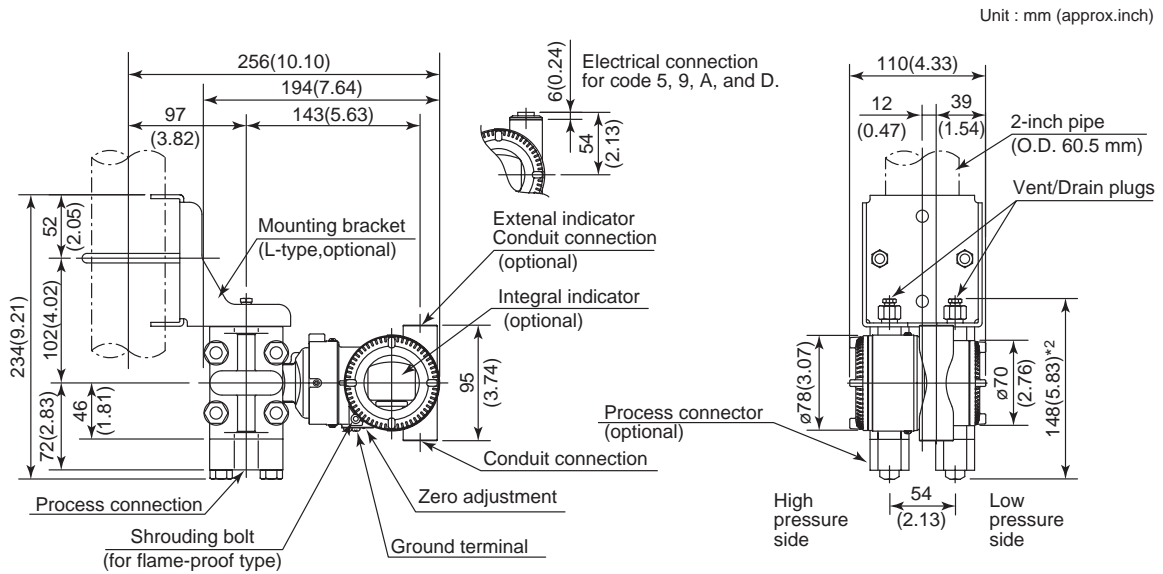

### ● Horizontal Impulse Piping Type (INSTALLATION CODE '9') (For CODE '8', refer to the notes below.)

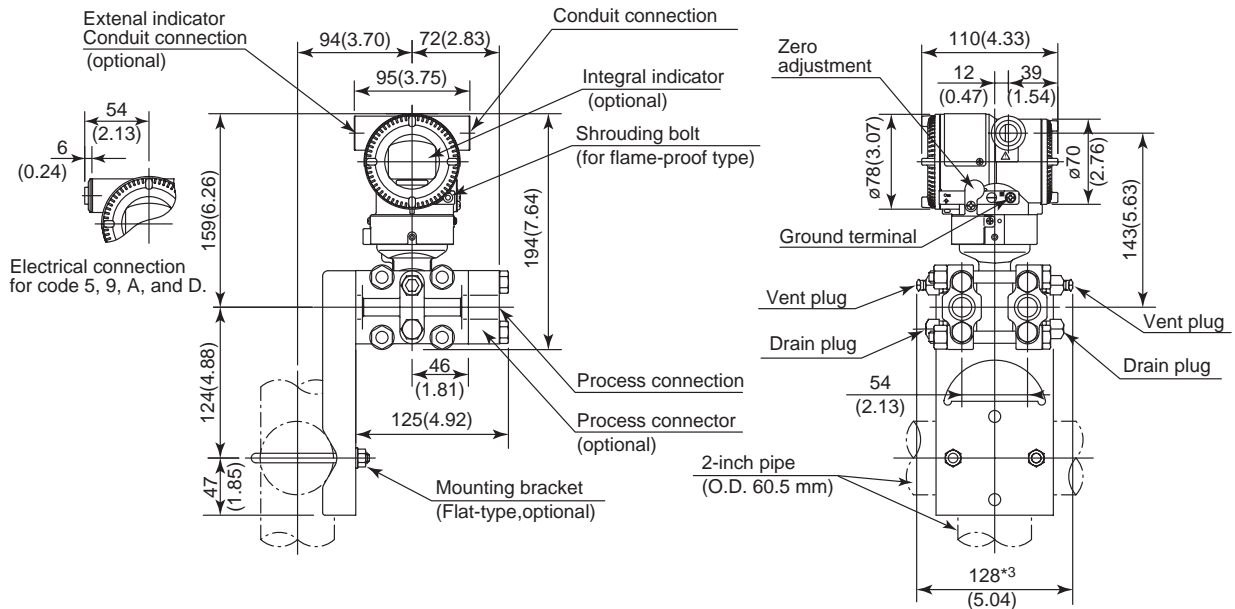

\* 1: When installation code 8 is selected, high and low pressure side on above figure are reversed. (i.e. High pressure side is on the right side.)

\* 2: When option code K1, K2, K5 or K6 is selected, add 15mm(0.59 inch) to the value in the figure.

\* 3: When option code K1, K2, K5 or K6 is selected, add 30mm(1.18 inch) to the value in the figure.

● Universal Flange (INSTALLATION CODE 'U')

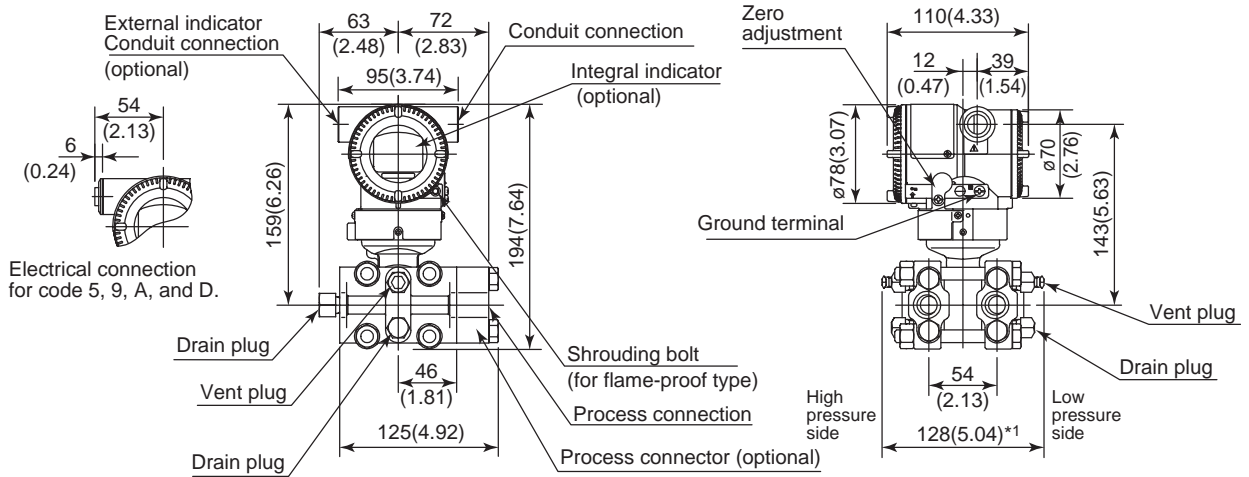

\*1: When Option code K1, K2, K5, or K6 is selected, add 30 mm (1.18 inch) to the value.

● Terminal Configuration

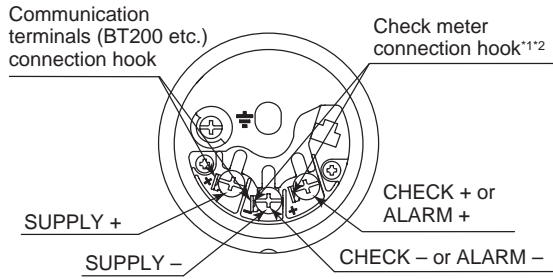

● Terminal Wiring

SUPPLY	+	Power supply and output terminal
	-	
CHECK	+	External indicator (ammeter) terminal*1*2
	-	or
ALARM	+	Status contact output terminal*2
	-	(when /AL is specified)
	⏏	Ground terminal

\*1: When using an external indicator or check meter, the internal resistance must be 10 Ω or less. A check meter or indicator cannot be connected when /AL option is specified.

\*2: Not available for fieldbus communication type.

F05E.EPS

● Wiring Example for Analog Output and Status Output

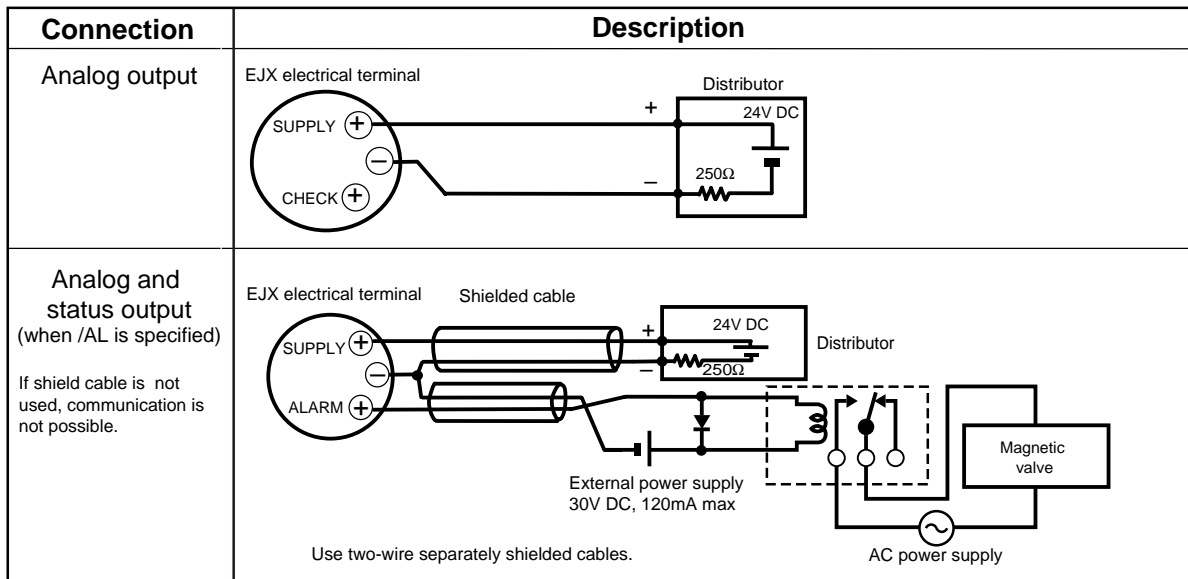

F06E.EPS

< Ordering Information > “◇”

Specify the following when ordering

1. Model, suffix codes, and option codes
2. Calibration range and units
  - 1) Calibration range can be specified with range value specifications up to 5 digits (excluding any decimal point) for low or high range limits within the range of -32000 to 32000. When reverse range is designated, specify Lower Range Value(LRV) as greater than Upper Range Value(URV). When square root output mode is specified, LRV must be “0 (zero) ”.
  - 2) Specify only one unit from the table, ‘Factory setting.’
3. Select linear or square root for output mode and display mode.
 

Note: If not specified, the instrument is shipped set for linear mode.
4. Display scale and units (for transmitters equipped with the integral indicator only)
 

Specify either 0 to 100 % or ‘Range and Unit’ for engineering units scale:  
 Scale range can be specified with range limit specifications up to 5 digits (excluding any decimal point) for low or high range limits within the range of -32000 to 32000. Unit display consists of 6-digit, therefore, if the specified scaling unit excluding ‘/’ is longer than 6-characters , the first 6 characters will be displayed on the unit display.
5. Tag Number (if required)
 

For BRAIN communication type, specify upto 16 letters. The specified letters will be written in the amplifier memory and engraved on the tag plate.  
 For HART communication type, specify software tag (up to 8 letters) to be written on the amplifier memory and Tag number(up to 16 letters) to be engraved on the tag plate seperately.
6. Other factory configurations (if required)
 

Specifying option code **CA** or **CB** will allow further configuration at factory. Following are configurable items and setting range.

[/CA : For HART communication type]

  - 1) Descriptor(up to 16 characters)
  - 2) Message (up to 30 characters)
  - 3) Software damping in second (0.00 to 100.00)

[/CB : For BRAIN communication type]

  - 1) Software damping in second (0.00 to 100.00)

< Factory Setting > “◇”

Tag number	As specified in order
Software damping *1	‘2.00 sec’ or as specified in order
Output mode	‘Linear’ unless otherwise specified in order
Calibration range lower range value	As specified in order
Calibration range upper range value	As specified in order
Calibration range unit	Selected from mmH <sub>2</sub> O, mmH <sub>2</sub> O(68°F), mmAq <sup>*2</sup> , mmWG <sup>*2</sup> , mmHg, Pa, hPa <sup>*2</sup> , kPa, MPa, mbar, bar, gf/cm <sup>2</sup> , kgf/cm <sup>2</sup> , inH <sub>2</sub> O, inH <sub>2</sub> O(68°F), inHg, ftH <sub>2</sub> O, ftH <sub>2</sub> O(68°F) or psi. (Only one unit can be specified.)
Display setting	Designated differential pressure value specified in order. (% or user scaled value.) Display mode ‘Linear’ or ‘Square root’ is also as specified in order.

T07E.EPS

\*1: To specify these items at factory, option code **CA** or **CB** is required.

\*2: Not available for HART protocol type.