

General Specifications

EJX930A Multivariable Transmitter



GS 01C25R04-01E

[Style: S1]

The high performance EJX930A multivariable transmitter features a single-crystal silicon resonant sensor and is suitable to measure liquid, gas, or steam mass flow. The EJX930A outputs a 4 to 20 mA DC signal corresponding to the measured differential pressure, static pressure, process temperature, or dynamically calculated and fully compensated mass flow.

FOUNDATION fieldbus protocol type is also available.

Key features:

- 1.0% mass flow rate accuracy over 1:10 flow range
- Advanced diagnostic function (option)
- [HART protocol type]
- Simultaneous dual output of 4 to 20mA and pulse signals.
- HART protocol revision selectable from 5 (HART 5) or 7 (HART 7)
- Long tag supporting up to 32 characters (HART 7)
- Enhanced burst mode and event notification (HART 7)
- SIL2 for safety requirement

Note: HART 5 stands for HART protocol revision 5
HART 7 stands for HART protocol revision 7

[FOUNDATION Fieldbus protocol type]

- Various function blocks available; 5 AIs, AR, IT, SC, and IS as standard. PID as an optional feature.
- Cyclically displays up to 10 variables
- Software download function (option)

STANDARD SPECIFICATIONS

SPAN AND RANGE LIMITS

Differential Pressure (DP)

| Measurement Span/Range | kPa | inH ₂ O/(D1) | mbar/(D3) | mmH ₂ O/(D4) |
|------------------------|-------|-------------------------|---------------|-------------------------|
| M | Span | 1 to 100 | 4 to 400 | 10 to 1000 |
| | Range | -100 to 100 | -400 to 400 | -1000 to 1000 |
| H | Span | 5 to 500 | 20 to 2000 | 50 to 5000 |
| | Range | -500 to 500 | -2000 to 2000 | -5000 to 5000 |

T01E.EPS

Static Pressure (SP)

Absolute Pressure

| Measurement Span/Range | MPa abs | psia/(D1) | bar abs(D3) | kgf/cm ² abs(D4) |
|------------------------|---------|-----------|-------------|-----------------------------|
| M | Span | 1 to 32 | 145 to 4500 | 10 to 320 |
| | Range | 0 to 32 | 0 to 4500 | 0 to 320 |

T02E.EPS

Gauge Pressure (Sealed gauge)

| Measurement Span/Range | MPa | psi/(D1) | bar/(D3) | kgf/cm ² (D4) |
|------------------------|-------|------------|---------------|--------------------------|
| M | Span | 1 to 32 | 145 to 4500 | 10 to 320 |
| | Range | -0.1 to 32 | -14.5 to 4500 | -1 to 320 |

T03E.EPS



External Temperature (ET) (Pt100 ohm)

| Measurement External Temperature Span/Range | °C | °F | K | |
|---|-------------------|--------------|--------------|------------|
| M | Span | 10 to 1050 | 18 to 1890 | 10 to 1050 |
| | Range | -200 to 850 | -328 to 1562 | 73 to 1123 |
| | Fixed Temperature | -273 to 1927 | -459 to 3500 | 0 to 2200 |

T04E.EPS

PERFORMANCE SPECIFICATION

Zero-based calibrated span output, and silicone oil, unless otherwise mentioned.

For Fieldbus communication type, use calibrated range instead of span in the following specifications.

Specification Conformance

EJX series ensures specification conformance to at least $\pm 3\sigma$.

Mass Flow (For Measurement Function Code B)

Mass Flow Reference Accuracy

$\pm 1.0\%$ of Mass Flow Rate over 10:1 flow range. (100:1 DP range) for liquids and gases.

Totalized Mass Flow Reference Accuracy

1.0% of Total Mass Flow.

Note: Assume 100:1 DP range for liquids and gases.

Conditions for mass flow accuracy

- (1) Auto compensation mode.
- (2) M and H capsule
- (3) Uncalibrated differential producer (Orifice) installed based on the following standards. *1
- (4) Uncertainties for discharge coefficient, primary device bore, pipe diameter, and gas expansion factor defined on following standards. *1
- (5) Density uncertainty less than 0.1%.

*1: Standards: ISO5167-1 1991, ISO5167-2 2003, ASME, MFC-3M 1989, AGA No.3 1992

Differential Pressure (DP)

Reference Accuracy of Calibrated Span
(Includes terminal-based linearity, hysteresis, and repeatability)

| | | |
|-------------------------|----------|-----------------------------------|
| Measurement span | | H |
| Reference accuracy | X ≤ span | ±0.04% of Span |
| | X > span | ±(0.005+0.0049 URL/span)% of Span |
| X | | 70 kPa (280 inH ₂ O) |
| URL (upper range limit) | | 500 kPa (2000 inH ₂ O) |

T05E.EPS

| | | |
|-------------------------|----------|-----------------------------------|
| Measurement span | | M |
| Reference accuracy | X ≤ span | ±0.04% of Span |
| | X > span | ±(0.005+0.0035 URL/span)% of Span |
| X | | 10 kPa (40 inH ₂ O) |
| URL (upper range limit) | | 100 kPa (400 inH ₂ O) |

T06E.EPS

Ambient Temperature Effects per 28°C (50°F) Change

| Capsule | Effect |
|---------|---------------------------|
| H | ±(0.07% Span+0.0125% URL) |
| M | ±(0.07% Span+0.009% URL) |

Static Pressure Effects per 6.9 MPa (1000 psi) Change

Span Effects
M and H capsules
±0.075% of span

Effect on Zero

| Capsule | Effect |
|---------|-------------|
| H | ±0.028% URL |
| M | ±0.02% URL |

Overpressure Effects

Overpressure condition: up to maximum working pressure
M and H capsules
±0.03% of URL

Static Pressure (SP)

Reference Accuracy of Calibrated Span for Absolute pressure
(Includes terminal-based linearity, hysteresis, and repeatability)

| | |
|---------|--------------------|
| Capsule | Reference accuracy |
| M, H | ±0.1% of span |

T07E.EPS

Note :Gauge pressure reference is 1013.25 hPa (1 atm)
The gauge pressure variable is based on the above reference accuracy and can be affected by changes in the atmospheric pressure.

Ambient Temperature Effects per 28°C (50°F) Change

| Capsule | Effect |
|---------|------------------------|
| M, H | ±0.14% span±0.018% URL |

External temperature (ET)

Accuracy (Includes terminal-based linearity, hysteresis, and repeatability)

| | |
|---------|-----------------|
| Capsule | Accuracy |
| M, H | ±0.5°C (±0.9°F) |

T08E.EPS

Specification for External temperature is the transmitter portion only.
Sensor errors caused by the RTD are not included.
The transmitter is compatible with any Pt100 RTD conforming to IEC 751.
Input/output signal is non-isolated.

Ambient Temperature Effects per 28°C (50°F) Change

| Capsule | Effect |
|---------|-----------------|
| M, H | ±0.5°C (±0.9°F) |

Power Supply Effects

±0.005 % per Volt (from 21.6 to 32 V DC, 350Ω)

Vibration Effects

| | |
|-----------------------|-----------------|
| Signal | Effect |
| Differential Pressure | ±0.1% of URL |
| Static Pressure | ±0.1% of URL |
| External Temperature | ±0.5°C (±0.9°F) |

T09E.EPS

When tested per the requirements of IEC60770-1 field or pipeline with high vibration level (10-60 Hz, 0.21 mm peak to peak displacement /60-2000 Hz 3g)

Mounting Position Effects

Rotation in diaphragm plane has no effect.
Tilting up to 90 degree will cause zero shift up to 0.4 kPa (1.6 inH₂O) which can be corrected by the zero adjustment.

Response Time

| | | | |
|-----------------------|---------|----------|------------|
| Signal | Capsule | HART | Fieldbus*1 |
| Differential Pressure | M, H | 250 msec | 350 msec |
| Static Pressure | M, H | 200 msec | 300 msec |

T10E.EPS

When amplifier damping is set to zero and including dead time.

*1: Output from transducer block.

FUNCTIONAL SPECIFICATIONS

Output specifications for HART Protocol Type

Output

Dual output (Both analog and pulse/contact output can be obtained simultaneously).
In this case refer to the item "Wiring example for analog output and status/pulse output".

HART Protocol Revision

HART protocol revision can be selected from 5 or 7 when ordering.

The protocol revision can be changed by user configuration.

Note: Protocol revision supported by HART configuration tool must be the same or higher than that of the EJX multivariable transmitter.

| | | | |
|--|---|--|---|
| | | Protocol revision supported by HART configuration tool | |
| | | 5 | 7 |
| Protocol revision of EJX multivariable transmitter | 5 | ○ | ○ |
| | 7 | × | ○ |

○: Communication OK
 ×: Communication NG

T11_03E.EPS

Analog Output

Two wire 4 to 20 mA DC output, user-selectable for Differential Pressure, Static Pressure, External Temperature or Flow Rate signal.

Output range: 3.8 mA to 21.6 mA.

Digital HART FSK protocol are superimposed on the 4 to 20 mA signal.

Failure Alarm

- Analog output status at CPU failure and hardware error
 Up-scale: 110%, 21.6 mA DC or more (standard)
 Down-scale: -2.5%, 3.6 mA DC or less
- Analog output status at process abnormality (Option code /DG6);
 The result of process abnormality detected by the advanced diagnostic function can be reflected to an analog alert status. The following three setting modes are available.

| | | | | |
|-------------|-----|------------------------|---|---------------|
| | | Mode | | |
| | | Burnout | Fall back | Off |
| Standard | | 110 %, 21.6mA or more | Holds to a specified value within the output range from 3.8mA to 21.6mA | Normal output |
| Option Code | /C1 | -1.25%, 3.8mA or less | | |
| | /C2 | -1.25%, 3.8mA or less | | |
| | /C3 | 103.1%, 20.5mA or more | | |

T11_02E.EPS

Pulse/Contact Output

Pulse or status output is selected by parameter setting.

Transistor contact output (sink type).

Contact rating: 10.5 to 30 V DC, 120 mA DC max.

Low level: 0 to 2 V DC. (Refer to Figure 1)

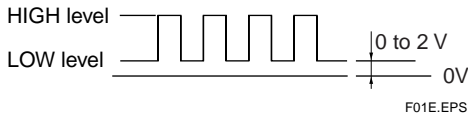

F01E.EPS

Figure 1. High and low level (Pulse output)

Pulse Output

Scaled pulse or frequency pulse output is selected by parameter setting.

Scaled Pulse Output Function

Pulse is output by the unit of the scaled flow rate. Scaled pulse can be totalized.

Frequency Output Function

Number of pulses output per second at 100% of output.

Pulse frequency: Max. 10 kHz

Duty cycles: Approx. 50% (1:2 to 2:1)

Contact Output Function

High or low alarm

Status signal output mode can be reversed (ON/OFF).

Table 1. Signal Output

| Output | Flow rate ^{*1} | Differential pressure | Static pressure | External temperature | Total flow ^{*1} |
|----------------|-------------------------|-----------------------|-----------------|----------------------|--------------------------|
| 4-20mA | ✓ ^{*3} | ✓ ^{*2} | ✓ | ✓ | |
| Pulse output | ✓ | | | | ✓ |
| High/Low alarm | ✓ | ✓ | ✓ | ✓ | |

T11E.EPS

*1: When Measurement Function Code B is specified.

*2: Square root output is not available. Low cut linear mode is not supported.

*3: Reversed output is not available.

Output specifications for FOUNDATION Fieldbus Protocol Type

Output

Digital communication signal based on the FOUNDATION fieldbus specification.

Functional Specifications

Functional specifications for Fieldbus communication conform to the standard specification (H1) of FOUNDATION fieldbubs.

Function Block

Table 2. Function Block

| Block name | Number | Execution time | Note |
|------------|--------|----------------|--|
| AI | 5 | 30 msec | For flow, differential pressure, static pressure, external temperature and capsule or amplifier temperature. |
| SC | 1 | 30 msec | An output of Signal characterizer block is a non-linear function of the respective input. The function is determined by a table. |
| IT | 1 | 30 msec | Integrator block intergrates a variable as a function of the time of accumulates the counts. |
| IS | 1 | 30 msec | Input Selector block provides selection of up to eight inputs and generate an output based on the configured action. |
| AR | 1 | 30 msec | Arithmetic block allows simple use of popular measurement math functions. |
| PID | 1 | 45 msec | Applicable when /LC1 option is specified. |

T12E.EPS

LM Function

LM function is supported.

Advanced Diagnostics (optional)

- Impulse line blockage detection
The impulse line condition can be calculated and detected by extracting the fluctuation component from the differential pressure and static pressure signals. Also EJX930A detects the impulse line abnormality particularly which side of impulse line is plugged.
- Heat trace monitoring
The change of the flange temperature calculated by using the two temperature sensors built in the EJX930A enables to detect the heat trace breakage or the abnormal temperature due to the failure.

Damping Time Constant (1st order)

Amplifier damping time constant is adjustable from 0.00 to 100.00 seconds and added to response time, applicable for DP, SP, ET, and flow independently.

Update Period

Table 3. Update Period

| Signal | HART | Fieldbus |
|-----------------------|-----------|----------|
| Flow rate | 100 msec | 200 msec |
| Differential pressure | 100 msec | 200 msec |
| Static pressure | 100 msec | 200 msec |
| External temperature | 400 msec | 800 msec |
| Total flow | 1000 msec | ——* |

T13E.EPS

*: Output from IT function block.

Zero Adjustment Limits

Zero can be fully elevated or suppressed, within the lower and upper range limits of the capsule, applicable for DP, SP, and ET independently.

External Zero Adjustment(for HART communication type)

External zero for DP is continuously adjustable with 0.01% incremental resolution of span.

Integral Indicator (LCD)

5-digit (Flow, DP, SP, and ET) or 6-digit (Total flow) numerical display, 6-digit unit display and bar graph. The indicator is configurable to display one or up to four variables periodically.

For FOUNDATION Fieldbus, the indicator is configurable to display up to ten function block output values.

Burst Pressure Limits

69 MPa (10000 psi)

Self Diagnostics

CPU failure, hardware failure, configuration error, process alarm for differential pressure, static pressure and capsule temperature.

SIL Certification

EJX series transmitters except Fieldbus communication type are certified by TÜV in compliance with the following standards;

IEC 61508: 2000; Part1 to Part 7

Functional Safety of electrical/electronic/programmable electronic safety-related systems; SIL 2 capability for single transmitter use, SIL 3 capability for dual transmitter use.

Functions Applicable for HART Protocol Revision 7

- Long tag supporting up to 32 characters
Long tag secures a better asset management with abundant digits in its software.
- Enhanced burst mode and event notification
Advanced burst mode includes the variety of transmission setting by specifying burst variables, update period, and message trigger mode, and event notification function gives you alert signal based on the status change in preset values and self-diagnosis.
- Squawk
Identifying the transmitter by displaying the particular pattern on LCD
- Multidrop communication
Up to 63 transmitters can be connected. An analog signal output available for one device in a loop.

■ Mass Flow Calculation

Auto Compensation Mode (FSA120 FieldMate FlowNavigator is required for configuration)

Configuration of the fluid physical properties and primary element for the EJX900 series can be performed using a dialog window of FSA120.

All flow factors for mass flow calculation are dynamically compensated to an optimum value.

In Auto mode, mass flow can be measured with high accuracy.

The flow factors that are automatically compensated are discharge coefficient, diameter of primary device, upstream internal pipe diameter, gas expansion factor, density, and viscosity.

FlowNavigator: FSA120 Flow Configuration Software (refer to GS 01C25R51-01E) . The software package is used to perform mass flow configuration for the EJX930A. These software can also read and write the general parameters of HART communications or FOUNDATION Fieldbus communication. Configuration of the fluid physical properties and the primary element of the EJX900 series can be done by means of a dialog menu.

Basic Flow Calculation Mode

Flow operation and density compensation are performed conventionally, with the flow factors being input manually.

The operational expression is switched by the fluid type and the unit setting.

Density compensation by phase

Gas: Compensation as ideal gas by temperature and pressure.

Liquid: Compensation by temperature.

Flow unit categories refer to Table 4.

Table 4. Flow Operational Expression

| Fluid type | Flow unit Category | Flow equation |
|------------|-------------------------------|--|
| Liquid | Mass Flow | $Q_m, Q_v \text{ or } Q_{v_norm} = \frac{Kfactor}{\rho}$ *1 |
| | Normal · Standard Volume Flow | $\times \sqrt{\Delta P \times (1 + \frac{Temp K1}{T - T_b})}$ |
| | Volume Flow | |
| Gas | Mass Flow | $Q_m \text{ or } Q_{v_norm} = \frac{Kfactor}{\rho}$ *1 |
| | Normal · Standard Volume Flow | $\times \sqrt{\Delta P \times \frac{T_b}{T} \times \frac{SP}{SP_b}}$ |
| | Volume Flow | $Q_v = \frac{Kfactor}{\rho} \times \sqrt{\Delta P \times \frac{T_b}{T} \times \frac{SP_b}{SP}}$ *1 |

T16E.EPS

*1 == User setting Parameter

Table 5. Symbol

| Symbol | Description |
|---------|--|
| Qm | Mass Flow |
| Qv | Volume Flow |
| Qv_norm | Normal-Standard Volume Flow |
| Kfactor | Basic flow Calculation factor |
| ΔP | Differential Pressure (Transmitter Setting unit) |
| Tb | Reference temperature unit: K |
| T | Temperature unit: K |
| SPb | Reference static pressure unit: kPa abs |
| SP | Static Pressure unit: kPa abs |
| Temp K1 | The density rate of change per temperature 1degC of a density base value (value which set 100% to 1) For Volume Flow: Set 0 |

T17E.EPS

■ NORMAL OPERATING CONDITION

(Optional features or approval codes may affect limits.)

Ambient Temperature Limits

- 40 to 85°C (-40 to 185°F)
- 30 to 80°C (-22 to 176°F) with LCD display

Process Temperature Limits

- 40 to 120°C (-40 to 248°F)

Ambient Humidity Limits

- 0 to 100% RH

Working Pressure Limits (Silicone oil)

Maximum Pressure Limits

| | |
|-----------------|-------------------|
| M and H Capsule | 32 MPa (4500 psi) |
|-----------------|-------------------|

Minimum Pressure Limit

See graph below

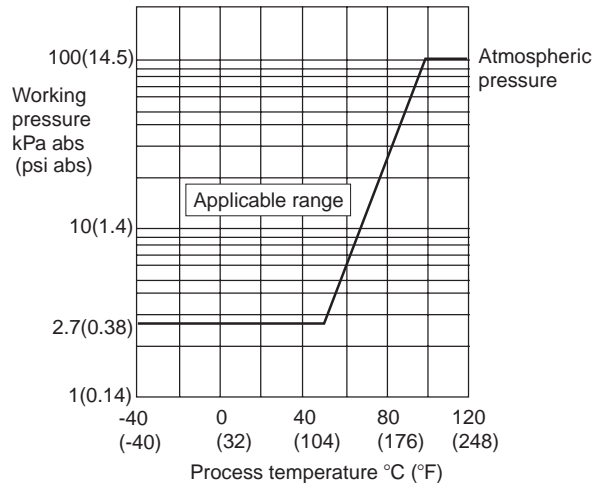

F02E.EPS

Figure 2. Working Pressure and Process Temperature

Supply & Load Requirements(Output Signal code E,J)

(Optional features or safety approvals may affect electrical requirements.)

With 24 V DC supply, up to a 570 Ω load can be used. See graph below.

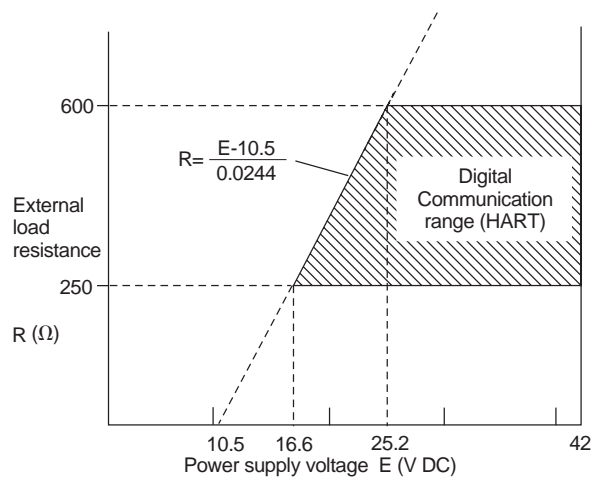

F03E.EPS

Figure 3. Relationship Between Power Supply Voltage and External Load Resistance

Supply Voltage

[for HART]

- 10.5 to 42 V DC for general use and flameproof type.
- 10.5 to 32 V DC for lightning protector (Option code / A).

10.5 to 30 V DC for intrinsically safe, type n or nonincendive.

Minimum voltage limited at 16.6 V DC for HART communication.

[for FOUNDATION fieldbus]

9 to 32 V DC for general use, flameproof type, Type n or nonincendive.

Load (Output signal code E, J)

0 to 1335 Ω for operation
250 to 600 Ω for digital communication

FOUNDATION Fieldbus**Communication Requirements**

Supply Voltage: 9 to 32 V DC
Current draw :
Steady state 15 mA (max)
Software download state 24 mA (max)

EMC Conformity Standards, CE , N200

EN61326-1 Class A, Table2 (For use in industrial locations)
EN61326-2-3

European Pressure Equipment Directive

Sound Engineering Practice (for all capsules)

With option code /PE3 (for M and H capsules)



Category III, Module H, Type of Equipment : Pressure Accessory-Vessel, type of Fluid: Liquid and Gas, Group of fluid: 1 and 2

□ PHYSICAL SPECIFICATIONS**Wetted Parts Materials**

Diaphragm, Cover Flange, Process Connector, Capsule Gasket, and Vent/Drain Plug
Refer to "MODEL AND SUFFIX CODE."

Process Connector Gasket

PTFE Teflon
Fluorinated rubber for Option code /N2 and /N3

Non-wetted Parts Materials**Bolts**

B7 carbon steel, 316L SST, or 660 SST

Housing

Low copper cast aluminum alloy with polyurethane, mint-green paint (Munsell 5.6BG 3.3/2.9 or its equivalent) or ASTM CF-8M stainless steel

Degrees of Protection

IP66/IP67, NEMA4X

Cover O-rings

Buna-N, fluoro-rubber (optional)

Name plate and tag

316 SST

Fill Fluid

Silicone oil, Fluorinated oil (option)

Cable for RTD

External Temperature Input Code -1, -2, -3, -4
Oil-proof and a heat-resistant cable with a shield
Outside diameter: 8.5 mm (0.335 inch),
Voltage rating: 300V
Temperature rating: -40 to 105°C (-40 to 221°F)
Flame resistance: UL (CSA) VW-1
Adaptation standard: UL (CSA) AWM STYLE 2517

External Temperature Input Code -B,-C,-D

A heat-resistant FEP cable with a shield
Outside diameter: 4.3mm (0.168 inch)
Voltage rating: 300V
Temperature rating: -80 to 200°C (-112 to 392°F)
Flame resistance: NEC Article 800-CMP
Adaptation standard: NEC Article 725-PLTC

Note for using an extension cable:

When extending a temperature cable with using an extension cable and a junction box, total cable length including the original external temperature cable must be less than 25 m. Use PE or XLPE insulated cable for extension.

Cable gland:

Nickel plating brass

Weight

6.8 kg (14.3 lb) without integral indicator, mounting bracket, process connector and RTD cable.
Add 1.5 kg (3.3 lb) for Amplifier housing code 2.

Connections.

Refer to "MODEL AND SUFFIX CODE."
Process Connection of Cover Flange: IEC61518

< Related Instruments >

Power Distributor: Refer to GS 01B04T01-02E or GS 01B04T02-02E
FSA120 Flow Configuration Software (FieldMate FlowNavigator) GS 01C25R51-01E

< Reference >

1. Teflon; Trademark of E.I. DuPont de Nemours & Co.
2. Hastelloy; Trademark of Haynes International Inc.
3. HART; Trademark of the HART Communication Foundation.
4. AIChE, DIPPR (Design Institute for Physical Properties); Trademarks of American Institute of Chemical Engineers.
5. AGA; Trademark of American Gas Association.
6. FOUNDATION Fieldbus; Trademark of Fieldbus Foundation.

Other company/organization and/or product names are registered trade marks of their respective holders.

MODEL AND SUFFIX CODES

| Model | Suffix Codes | Description |
|-------------------------------|--|---|
| EJX930A | | Multivariable transmitter |
| Output signal | -E -J -F | 4 to 20 mA DC with digital communication (HART protocol) *9 4 to 20 mA DC with digital communication (HART 5/HART 7 protocol) *10 Digital communication (FOUNDATION fieldbus protocol) |
| Measurement span (Capsule) | M H | 1 to 100 kPa (4 to 400 inH ₂ O) 5 to 500 kPa (20 to 2000 inH ₂ O) |
| Wetted parts material *1 | S | Refer to Table 7. |
| Process connections | 3 4 5 | with 1/4 NPT female process connector *8 with 1/2 NPT female process connector *8 without process connector (1/4 NPT female on the cover flanges) |
| Bolts and nuts material | J G C | B7 carbon steel 316L SST 660 SST |
| Installation | -7 -8 -9 | Vertical piping, left side high pressure, and process connection downside Horizontal piping and right side high pressure Horizontal piping and left side high pressure |
| Amplifier housing | 1 2 | Cast aluminum alloy ASTM CF-8M stainless steel |
| Electrical connection | F 2 4 5 7 9 A C D | G 1/2 female, two electrical connections (One connection for RTD) 1/2NPT female, two electrical connections (One connection for RTD) M20 female, two electrical connections (One connection for RTD) G 1/2 female, two electrical connections and blind plug *2*6*7 1/2NPT female, two electrical connections and a blind plug *2*6*7 M20 female, two electrical connections and a blind plug *2*6*7 G 1/2 female, two electrical connections and a 316 SST blind plug *2 1/2 NPT female, two electrical connections and a 316 SST blind plug *2 M20 female, two electrical connections and a 316 SST blind plug *2 |
| Integral indicator | D N | Digital indicator None |
| Mounting bracket | B D J K N | 304 SST 2-inch pipe mounting, flat type (for horizontal piping) 304 SST 2-inch pipe mounting, L type (for vertical piping) 316 SST 2-inch pipe mounting, flat type (for horizontal piping) 316 SST 2-inch pipe mounting, L type (for vertical piping) None |
| External temperature input *3 | -0 ... -1 ... -2 ... -3 ... -4 ... -B ... -C ... -D ... | Fixed temperature (without cable) *5 RTD input with 0.5 m (1.64 ft) of shielded cable and two cable glands*7 RTD input with 4 m (13.1 ft) of shielded cable and two cable glands*7 RTD input with 7.5 m (24.6 ft) of shielded cable and two cable glands*7 RTD input with 25 m (81 ft) of shielded cable and two cable glands*7 RTD input with 4 m (13.1 ft) of shielded cable without cable gland *4 RTD input with 7.5 m (24.6 ft) of shielded cable without cable gland *4 RTD input with 25 m (81 ft) of shielded cable without cable gland *4 |
| Measurement function | A .. B .. | Multi Sensing (DP, P and T) Mass Flow Measurement (Flow, DP, P and T) |
| Option codes | | /□ Optional specification |

T18E.EPS

The “☆” marks indicate the most typical selection for each specification.

*1: ⚠ Users must consider the characteristics of selected wetted parts material and the influence of process fluids. The use of inappropriate materials can result in the leakage of corrosive process fluids and cause injury to personnel and/or damage to plant facilities. It is also possible that the diaphragm itself can be damaged and that material from the broken diaphragm and the fill fluid can contaminate the user's process fluids.

Be very careful with highly corrosive process fluids such as hydrochloric acid, sulfuric acid, hydrogen sulfide, sodium hypochlorite, and high-temperature steam (150°C [302°F] or above). Contact Yokogawa for detailed information of the wetted parts material.

*2: For External Temperature Input code 0 (Fixed temperature) .

*3: Recommended External Temperature Input Cable is as shown in Table 6. RTD is not provided.

*4: Specify when using conduit for RTD connection.

*5: Preset external temperature value is used for density compensation.

*6: Material of a blind plug is aluminum alloy or 304 SST.

*7: Not applicable for Amplifier housing code 2.

*8: Lower limit of ambient and process temperature is -15°C.

*9: Output signal code **E**: HART 5.

*10: Output signal code **J**: HART 5 or HART 7 selectable. Specify HART 5 or HART 7 when ordering. (Output signal code **J** is recommended for HART communication.)

Table 6. Recommended External Temperature Cable

| External Temperature Input Code | | -1, -2, -3, -4 | -B, -C, -D |
|---|---|----------------|------------|
| General Application | | ✓ | ✓ |
| Factory Mutual (FM) | Explosionproof Approval | | ✓ |
| | Intrinsically Safe Approval Nonincendive | | ✓ |
| CENELEC ATEX | Flameproof Approval | ✓ | |
| | Intrinsically Safe Approval | ✓ | |
| Canadian Standards Association (CSA) | Explosionproof Approval | | ✓ |
| IECEX Scheme | Flameproof Approval | ✓ | ✓ |

T19E.EPS

Table 7. Wetted Parts Materials

| Wetted parts material code | Cover flange | Process connector | Capsule | Capsule gasket | Drain/Vent plug |
|-------------------------------|--------------|-------------------|--|------------------------|-----------------|
| S # | F316 SST | ASTM CF-8M *1 | Hastelloy C-276 *2 (Diaphragm) 316L SST *3 (Others) | Teflon-coated 316L SST | 316 SST |

T20E.EPS

*1: Cast version of 316 SST. Equivalent to SCS14A.

*2: Hastelloy C-276 or ASTM N10276.

*3: 316L SST, F316L SST

The '#' marks indicate the construction materials conform to NACE material recommendations per MR0175/ISO 15156. Please refer to the latest standards for details. Selected materials also conform to NACE MR0103.

OPTIONAL SPECIFICATIONS (For Explosion Protected)

| Item | Description | Code |
|---------------------|--|-------------|
| Factory Mutual (FM) | FM Explosionproof Approval *4 Applicable Standard: FM3600, FM3615, FM3810, ANSI/NEMA 250 Explosionproof for Class I, Division 1, Groups B, C and D, Dust-ignitionproof for Class II/III, Division 1, Groups E, F and G, in Hazardous locations, indoors and outdoors (NEMA 4X) "FACTORY SEALED, CONDUIT SEAL NOT REQUIRED." Temperature class: T6, Amb. Temp.: -40 to 60°C (-40 to 140°F) *2 | FF1 |
| | FM Intrinsically Safe and Nonincendive Approval *3 *4 Applicable Standard: FM3600, FM3610, FM3611, FM3810, ANSI/NEMA 250, IEC60079-27 Intrinsically Safe for Class I,II, & III, Division 1, Groups A,B,C,D,F & G, Entity, FISCO. Class I, Zone 0, AEx ia IIC, Enclosure: "NEMA 4X", Temp. Class: T4, Amb. Temp.: -40 to 60°C (-40 to 140°F). *2 Intrinsically Apparatus Parameters : [FISCO (IIC)] Ui=17.5 V, li=380 mA, Pi=5.32 W, Ci=3.52 nF, Li=0 μH [FISCO (IIB)] Ui=17.5 V, li=460 mA, Pi=5.32 W, Ci=3.52 nF, Li=0 μH [Entity] Ui=24 V, li=250 mA, Pi=1.2 W, Ci=3.52 nF, Li=0 μH Sensor Circuit: Uo=6.51 V, Io=4 mA, Po=6 mW, Co=34 μF, Lo=500 mH Nonincendive for Class I, Division 2, Groups A, B, C and D, NIFW, FNICO Class I, Zone 2, Group IIC, NIFW, FNICO Class II, Division 2, Groups F&G, and Class III, Division 1 Enclosure: "NEMA 4X", Temp. Class: T4, Amb. Temp.: -40 to 60°C (-40 to 140°F) *2 Nonincendive Apparatus Parameters : Vmax.= 32 V, Ci = 1.76 nF, Li = 0 μH | FS15 |
| GENELEC ATEX | CENELEC ATEX (KEMA) Flameproof Approval *4 Applicable Standard: EN 60079-0, EN 60079-1, EN 61241-0, EN 61241-1 Certificate: KEMA 07ATEX0109 II 2G, 2D Exd IIC T4, T5, T6 Ex tD A21 IP6X T85, T100, T120 Degree of protection : IP66 and IP67 Amb. Temp. (Tamb) for gas-proof : T4 ; -50 to 75°C (-58 to 167°F), T5; -50 to 80°C (-58 to 176°F), T6; -50 to 75°C (-58 to 167°F) *2 Max. process Temp.(Tp): T4; 120°C (248°F), T5; 100°C (212°F), T6; 85°C (185°F) Max. surface Temp. for dust-proof : T85°C (Tamb: -40 to 40°C, Tp:85°C), T100°C (Tamb: -40 to 60°C, Tp:100°C), T120°C (Tamb: -40 to 80°C, Tp:120°C) *2 | KF21 |
| | CENELEC ATEX (KEMA) Intrinsically Safe Approval *1 *4 Applicable Standard: EN 50014, EN 50020, EN 50284, EN 50281-1-1 Certificate: KEMA 06ATEX0037X II 1G, 1D EEx ia IIC T4 Type of protection : IP66 and IP67 Amb. Temp. (Tamb) for gas-proof: -50 to 60°C (-58 to 140°F) *2 Maximum Process Temp.(Tp) for gas-proof: 120°C Electrical data: [Supply/Output circuit (terminals + and -)] Ui=30 V, li=200 mA, Pi=0.9 W, Ci=10 nF, Li=0 mH [Pulse Output circuit (terminals - and pulse)] Ui=30 V, li=200 mA, Pi=0.9 W, Ci=10 nF, Li=0 mH [External Temperature Input circuit (connector)] Uo=30 V, Io=95.4 mA, Po=468 mW, Co=11 nF, Lo=3.9 mH Max. surface Temp. for dust-proof: T85°C (Tamb: -40 to 60°C, Tp: 80°C), T100°C (Tamb: -40 to 60°C, Tp: 100°C), T120°C (Tamb: -40 to 60°C, Tp: 120°C) *2 | KS2 |
| | CENELEC ATEX (KEMA) Intrinsically Safe Approval *3 *5 | — |

T21E_1.EPS

| Item | Description | Code |
|--------------------------------------|--|------------|
| Canadian Standards Association (CSA) | CSA Explosionproof Approval *4 Certificate: 2014354 Applicable Standard: C22.2 No.0, C22.2 No.0.4, C22.2 No.0.5, C22.2 No.25, C22.2 No.30, C22.2 No.94, C22.2 No.60079-0, C22.2 No.60079-1, C22.2 No.61010-1-04 Explosion-proof for Class I, Groups B, C and D. Dustignition-proof for Class II/III, Groups E, F and G. When installed in Division 2, "SEAL NOT REQUIRED" Enclosure: TYPE 4X, Temp. Code: T6...T4 Ex d IIC T6...T4 Enclosure: IP66 and IP67 Max.Process Temp.: T4;120°C (248°F), T5;100°C (212 °F), T6; 85°C (185°F) Amb.Temp.: -50 to 75°C (-58 to 167°F) for T4, -50 to 80°C (-58 to 176°F) for T5, -50 to 75°C (-58 to 167°F) for T6 *2 Process Sealing Certification Dual Seal Certified by CSA to the requirement of ANSI/ISA 12.27.01 No additional sealing required Primary seal failure annunciation: at the zero adjustment screw | CF1 |
| | CSA Intrinsically Safe Approval *1 *5 | — |
| IECEX Scheme | IECEx Flameproof Approval *4 Applicable Standard: IEC 60079-0:2004, IEC60079-1:2003 Certificate: IECEx CSA 07.0008 Flameproof for Zone 1, Ex d IIC T6...T4 Enclosure: IP66 and IP67 Max.Process Temp.: T4;120°C (248°F), T5;100°C (212°F), T6; 85°C (185°F) Amb.Temp.: -50 to 75°C (-58 to 167°F) for T4, -50 to 80°C (-58 to 176°F) for T5, -50 to 75°C (-58 to 167°F) for T6 *2 | SF2 |

T21E_2.EPS

Contact Yokogawa representative for the codes indicated as '—'

- *1: Not Applicable for output signal code **-F**.
- *2: Lower limit of ambient temperature is -15°C (5°F) when **/HE** is specified.
- *3: Not Applicable for output signal code **-E** and **J**.
- *4: Applicable for electrical connection code **2, 4, 7, 9, C** and **D**.
- *5: Pending.

OPTIONAL SPECIFICATIONS

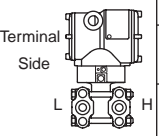
| Item | | Description | Code | |
|---|---|---|--|----|
| Painting | Color change | Amplifier cover only | P□ | |
| | | Amplifier cover and terminal cover, Munsell 7.5 R4/14 | PR | |
| | Coating change | Anti-corrosion coating*1 | X2 | |
| 316 SST exterior parts | | 316 SST zero-adjustment screw and setscrews*15 | HC | |
| Fluoro-rubber O-ring | | All O-rings of amplifier housing. Lower limit of ambient temperature: -15°C (5°F) | HE | |
| Lightning protector | | Transmitter power supply voltage: 10.5 to 32 V DC Allowable current: Max. 6000 A (1×40 μs), Repeating 1000 A (1×40 μs) 100 times Applicable Standards: IEC 61000-4-4, IEC 61000-4-5 | A | |
| Oil-prohibited use*2 | | Degrease cleansing treatment | K1 | |
| | | Degrease cleansing treatment with fluorinated oilfilled capsule. Operating temperature -20 to 80°C(-4 to 176°F) | K2 | |
| Oil-prohibited use with dehydrating treatment*2 | | Degrease cleansing and dehydrating treatment | K5 | |
| | | Degrease cleansing and dehydrating treatment with fluorinated oilfilled capsule. Operating temperature -20 to 80°C(-4 to 176°F) | K6 | |
| Capsule fill fluid | | Fluorinated oil filled in capsule Operating temperature -20 to 80°C(-4 to 176°F) | K3 | |
| Calibration units*3 | | P calibration (psi unit) | (See Table for Span and Range Limits.) D1 | |
| | | bar calibration (bar unit) | | D3 |
| | | M calibration (kgf/cm ² unit) | | D4 |
| Long vent*4 | | Total length: 119 mm (standard: 34 mm); Total length when combining with option code K1, K2, K5, and K6: 130 mm. Material: 316 SST | U1 | |
| Gold-plate *2 | | Surface of isolating diaphragms are gold plated, effective for hydrogen permeation. | A1 | |
| Output limits and failure operation*5 | | Failure alarm down-scale : Output status at CPU failure and hardware error is -2.5%, 3.6 mA DC or less. | C1 | |
| | | NAMUR NE43 Compliant Output signal limits: 3.8 mA to 20.5 mA | Failure alarm down-scale: Output status at CPU failure and hardware error is -2.5%, 3.6 mA DC or less. | C2 |
| | | | Failure alarm up-scale: Output status at CPU failure and hardware error is 110%, 21.6 mA or more. | C3 |
| Body option*6 |  | Right side high pressure, without drain and vent plugs | N1 | |
| | | N1 and Process connection, based on IEC61518 with female thread on both sides of cover flange, with blind kidney flanges on back. | N2 | |
| | | N2, and Material certificate for cover flange, diaphragm, capsule body, and blind kidney flange | N3 | |
| Wired tag plate | | 316 SST tag plate wired onto transmitter | N4 | |
| Data configuration at factory*7 | | Data configuration for HART communication type | Software damping, Descriptor, Message CA | |
| | | Data configuration for Fieldbus communication type | Software damping CC | |
| PID function*13 | | PID control function | LC1 | |
| Software downloading function*13 | | Based on FOUNDATION Fieldbus Specification(FF-883) Download class: Class1 | EE | |
| Advanced diagnostics | | Multi-sensing process monitoring • Impulse line blockage detection *16 • Heat trace monitoring | HART communication type DG6 | |
| | | | Fieldbus communication type *17 DG1 | |
| European Pressure Equipement Directive*14 | | PED 97/23/EC Category III, Module H, type of equipment: Pressure accessory-vessel, Tupe of fluid: Liquid and Gas, Group of fluid : 1 and 2 | PE3 | |
| Material certificate*8 | | Cover flange *9 | M01 | |
| | | Cover flange, Process connector *10 | M11 | |
| Pressure test/ Leak test certificate | | Test Pressure: 32 MPa(4500 psi) Nitrogen(N ₂) Gas or Water*12 Retention time: one minute | T09 | |

T22E.EPS

- *1: Not applicable with color or coating change option.
- *2: Applicable for Wetted parts material code **S**.
- *3: The unit of MWP (Max. working pressure) on the name plate of a housing is the same unit as specified by option codes **D1, D3, and D4**.
- *4: Applicable for vertical impulse piping type (Installation code **7**) and Wetted parts material code **S**.
- *5: Applicable for output signal codes **E** and **J**. The hardware error indicates faulty amplifier or capsule.
- *6: Applicable for wetted parts material code **S**; process connection codes **3, 4, and 5**; installation code **9**; and mounting bracket code **N**. Process connection faces on the other side of zero adjustment screw.
- *7: Also see 'Ordering Information'.
- *8: Material traceability certification, per EN 10204 3.1B.
- *9: Applicable for process connections codes **5**.
- *10: Applicable for process connections codes **3** and **4**.
- *11: The unit on the certificate is always Pa unit regardless of selection of option code **D1, D3** or **D4**.
- *12: Pure nitrogen gas or pure water is used for oil-prohibited use (option codes **K1, K2, K5, and K6**).
- *13: Applicable for output signal code **-F**.
- *14: Applicable for measurement span code **M** and **H**. If compliance with category III is needed, specify this code.
- *15: 316 or 316L SST. The specification is included in amplifier code **2**.
- *16: The change of pressure fluctuation is monitored and then detects the impulse line blockage. See TI 01C25A31-01E for detailed technical information required for using this function.
- *17: This option code must be specified with option code **EE**.

< Material Cross Reference >

| ASTM | JIS |
|-------|----------|
| 316 | SUS316 |
| F316 | SUSF316 |
| 316L | SUS316L |
| F316L | SUSF316L |
| 304 | SUS304 |
| F304 | SUSF304 |
| 660 | SUH660 |
| B7 | SNB7 |
| CF-8M | SCS14A |

T22E_02.EPS

DIMENSIONS

Model EJX930A

Unit: mm(approx. inch)

● Vertical Impulse Piping Type (Installation code 7)

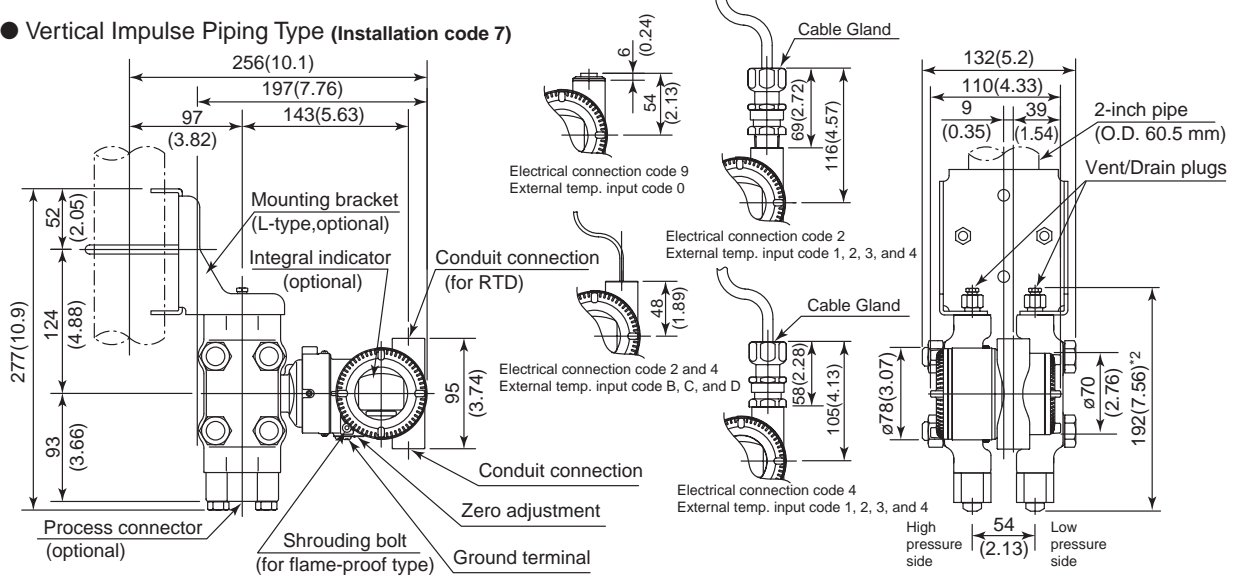

● Horizontal Impulse Piping Type (Installation code 9)

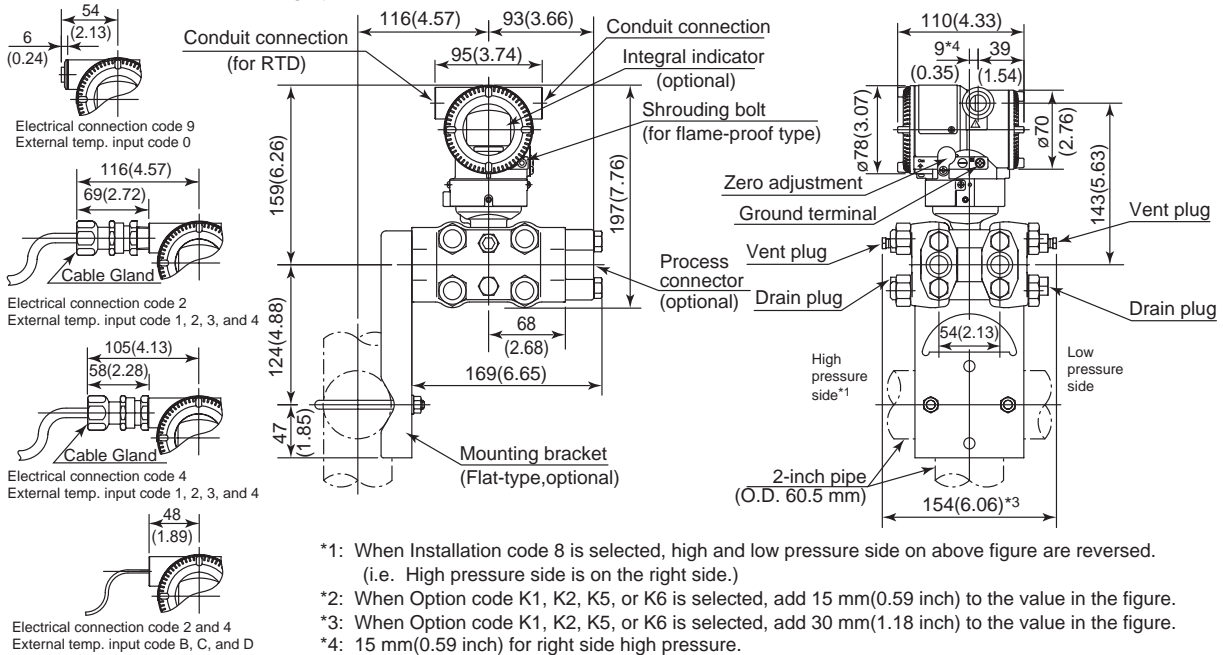

● Terminal Configuration

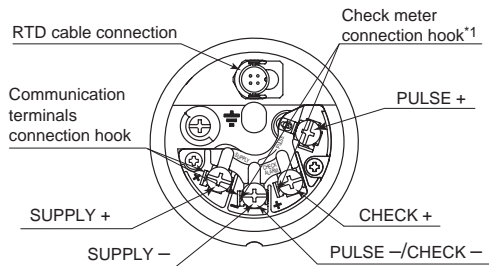

● Terminal Wiring

| | |
|----------|---|
| SUPPLY + | Power supply and output terminal |
| CHECK + | External indicator(ammeter) terminal*1 |
| PULSE + | Pulse or status contact output terminal |
| ⏏ | Ground terminal |

*1: When using an external indicator or check meter, the internal resistance must be 10 Ω or less.

● Wiring Example for Analog Output and Status/Pulse Output(for HART Protocol type)

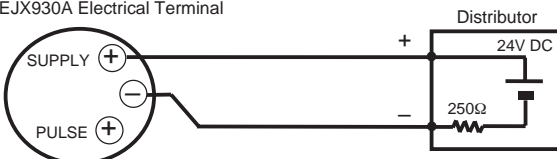
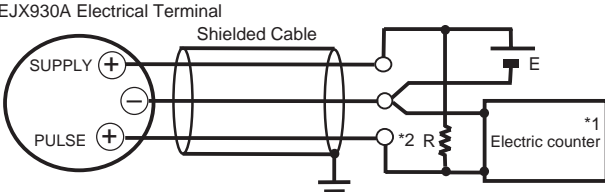
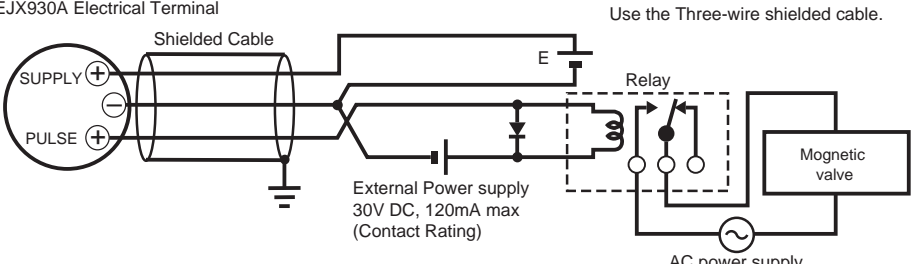
| Connection | Description |
|---|---|
| <p>Analog Output</p> <p>In this case, Communication is possible (up to a distance of 2km when a CEV cable is used.)</p> | <p>EJX930A Electrical Terminal</p>  <p>Distributor</p> <p>24V DC</p> <p>250Ω</p> |
| <p>Pulse Output</p> <p>In this case, No communication is possible.</p> | <p>EJX930A Electrical Terminal</p> <p>Use the Three-wire shielded cable.</p>  <p>Shielded Cable</p> <p>Electric counter *1</p> <p>*2 R</p> |
| <p>Status Output</p> <p>In this case, No communication is possible.</p> | <p>EJX930A Electrical Terminal</p> <p>Use the Three-wire shielded cable.</p>  <p>Shielded Cable</p> <p>Relay</p> <p>Magnetic valve</p> <p>External Power supply 30V DC, 120mA max (Contact Rating)</p> <p>AC power supply</p> |
| <p>Simultaneous Analog -Pulse Output *3</p> <p>Example 1</p> <p>In this case, Communication is possible (up to a distance of 2km when a CEV cable is used).</p> <p>Example 2</p> <p>In this case, Communication is possible (up to a distance of 200m when a CEV cable is used) and R = 1kΩ.</p> <p>Example 3</p> <p>In this case, No communication is possible (when shielded cable is not used).</p> | <p>When analog and pulse output are used, the length of communication line is subjected to wiring conditions. Refer to example 1 to 3.</p> <p>Distributor (or communication medium : ex. EP card)</p> <p>24V DC</p> <p>250Ω</p> <p>E(10.5 to 30V DC) Counting input</p> <p>Common</p> <p>Electric counter *1 (or communication medium : ex. EP card)</p> <p>Recorder or other instrument</p> <p>E(16.4 to 30V DC)</p> <p>Counting input</p> <p>Common</p> <p>Electric counter *1</p> <p>Recorder or other instrument</p> <p>E(16.4 to 30V DC)</p> <p>Counting input</p> <p>Common</p> <p>Electric counter *1</p> <p>EJX930A Electrical Terminal</p> <p>Shielded Cable</p> <p>*2 R</p> <p>EJX930A Electrical Terminal</p> <p>Shielded Cable</p> <p>250Ω</p> <p>*2 R</p> <p>EJX930A Electrical Terminal</p> <p>Shielded Cable</p> <p>250Ω</p> <p>*2 R</p> <p>E(16.4 to 30V DC)</p> <p>Counting input</p> <p>Common</p> <p>Electric counter *1</p> <p>For the shielded cables in this example of flowmeter installation, use two-wire separately shielded cables.</p> <p>This supply voltage requires a power source with a maximum output current of no less than E/R.</p> <p>For the shielded cables in this example of flowmeter installation, use two-wire separately shielded cables.</p> <p>This supply voltage requires a power source with a maximum output current of no less than E/R+25mA.</p> <p>The supply voltage requires output impedance no more than 1/1000 of R (load resistance).</p> <p>This supply voltage requires a power source with a maximum output current of no less than E/R+25mA.</p> |
| <p>The range of load resistance R for the pulse output.</p> | <p>The load resistance of pulse output should be used to 1kΩ, 2W.</p> <p>If no translation of the pulse output possible by the cable length or the frequency of the pulse output, the load resistance should be selected by calculation as shown below.</p> $\frac{E (V)}{120} \leq R (k\Omega) \leq \frac{0.1}{C (\mu F) \times f (kHz)}$ <p>Example of CEV cable capacitance ≒ 0.1μF/km</p> $P (mW) = \frac{E^2 (V)}{R (k\Omega)}$ <p>Where E = Supply voltage (V) f = Frequency of pulse output (kHz) R = Value of load resistance (kΩ) C = Cable capacitance (μF) P = Power ratio of the load resistance (mW)</p> |

*1: To avoid the influence of external noise, use an electric counter which fits to the pulse frequency.
 *2: Resistor is not necessary in case of an electric counter which can receive contact pulse signal directly.
 *3: When using analog and pulse output simultaneously, the HART communication may be influenced by noise comparing analog output only. Take countermeasure for noise shown above, e.g. use shield cable etc.

< Ordering Information for HART communication type>

Specify the following when ordering

1. Model, suffix codes, and option codes
2. Calibration range and units
 - 1) Calibration range can be specified with range value specifications up to 5 digits (excluding any decimal point) for low or high range limits within the range of -32000 to 32000.
When reverse range is designated, specify Lower Range Value (LRV) as greater than Upper Range Value (URV).
 - 2) Specify unit from the tables "Calibration Units"
3. Static pressure is selected from gauge pressure or absolute pressure.
4. TAG NO (if required)
Specified characters (up to 16 characters) are engraved on the stainless steel tag plate fixed on the terminal box.
5. SOFTWARE TAG (if required)
Specified characters^{*1} are set as "Tag" (the first 8 characters) and "Long tag"^{*2} (32 characters) in the amplifier memory.
When the "SOFTWARE TAG" is not specified, specified "TAG NO" is set as "Tag" (the first 8 characters) and "Long tag"^{*2} (16 characters) in the amplifier memory.
*1: Output signal code "E" (HART 5): up to 8 characters are specified
Output signal code "J" (HART 5/HART 7): up to 32 characters are specified
*2: applicable only for HART 7
6. Other factory configurations (if required) Specifying option code **CA** will allow further configuration at factory.
Following are configurable items and setting range.
 - 1) Descriptor (up to 16 characters)
 - 2) Message (up to 30 characters)
 - 3) Software damping in second (0.00 to 100.00)
7. When the output signal code is "J", specify the HART protocol revision "5" or "7".

Table 8-1. Factory Setting

| Parameter | Default value | Description |
|----------------------------|---------------------|--|
| Tag number | — | As specified in order |
| Flow unit | kg/h | Standard flow configuration |
| Flow LRV | 0 | Fluid: N2 Primary element type: ISO5167-1 1991 Orifice Corner Taps |
| Flow URV | 1000 | Upstream internal pipe diameter = 0.0527m (Carbon Steel) Diameter of primary device = 0.03162m (SUS304) |
| Flow Damping ^{*1} | 0.00 sec | Operating Pressure range = 0.1 to 1 MPa abs Operating Temperature range = 0 to 50°C |
| DP unit | kPa | Selectable from Table 10. Pressure Unit |
| DP LRV | 0 | As specified in order |
| DP URV | Max.span | |
| DP Damping ^{*1} | 2.00 sec | |
| SP A/G Selection | Absolute | As specified in order |
| SP unit | MPa | Selectable from Table 11. Static Pressure Unit |
| SP LRV | 0 | As specified in order |
| SP URV | 32 | |
| SP Damping ^{*1} | 1.00 sec | |
| ET unit | °C | Selectable from Table 12. Temperature Unit |
| ET LRV | -200 | As specified in order |
| ET URV | 850 | |
| ET Damping ^{*1} | 1.00 sec | |
| Fixed Temperature | 20°C (68°F) | When External Temperature Input Code 0 is specified. |
| Output signal | DP | When Measurement Function Code A is specified. |
| | Flow | When Measurement Function Code B is specified. |
| Display setting | DP range and unit | When Measurement Function Code A is specified. |
| | Flow range and unit | When Measurement Function Code B is specified. |

*1: To specify these items at factory, option code **CA** is required.

T23E.EPS

< Ordering Information for FOUNDATION Fieldbus communication type>

Specify the following when ordering

1. Model, suffix codes, and option codes
2. Calibration range and units for Differential pressure, Static pressure and external temperature
 - 1) Calibration range can be specified with range value specifications up to 5 digits (excluding any decimal point) for low or high range limits within the range of -32000 to 32000. When reverse range is designated, specify Lower Range Value (LRV) as greater than Upper Range Value (URV).
 - 2) Specify unit. See Table 8-2 for settable unit at factory.
3. Static pressure is selected from gauge pressure or absolute pressure.
4. Tag Number (if required)

Specify software tag (PD_TAG) up to 32 letters to be written on the amplifier memory and Tag number up to 16 letters to be engraved on the tag plate separately.
5. Output mode(AI1 L_TYPE) ;

Select one from 'Direct', 'indirect Linear' or 'indirect SQRT' for output mode of AI1(Differential pressure).
6. Output scale and unit(AI1 OUT_SCALE);

This setting is used for Indicator and output of AI1 block for Differential pressure. The scale range can be specified with range limit specifications up to 5 digit(excluding any decimal point) for low and high range limits within the range of -32000 to 32000. When AI1 L_TYPE is Direct, these setting does not affect the output of AI1 block.
7. Specify Node address in hexadecimal.
8. Select 'BASIC' or 'LINK MASTER' for Operation Functional Class.
9. Other factory configurations (if required) Specifying option code **CC** will allow further configuration at factory.

Following are configurable items and setting range.

Software damping in second (0.00 to 100.00)

Table 8-2. Factory Setting for Fieldbus

| Parameter | Default value | Description |
|-----------------------------|---------------------|---|
| Tag number | — | As specified in order |
| Software Tag (PD_TAG) | FT1001 | As specified in order |
| Flow unit (XD_SCALE of AI4) | kg/h | Standard flow configuration Fluid: N2 |
| Flow LRV (XD_SCALE of AI4) | 0 | Primary element type: ISO5167-1 1991 Orifice Corner Taps |
| Flow URV (XD_SCALE of AI4) | 1000 | Upstream internal pipe diameter = 0.0527m (Carbon Steel) Diameter of primary device = 0.03162m (SUS304) |
| Flow Damping *1 | 0.00 sec | Operating Pressure range = 0.1 to 1 MPa abs Operating Temperature range = 0 to 50°C |
| DP unit (XD_SCALE of AI1) | kPa | Selectable from kPa, MPa, Pa, hPa, mbar, bar, gf/cm ² , kgf/cm ² , mmH ₂ O, mmH ₂ O(68°F), inH ₂ O, inH ₂ O(68°F), ftH ₂ O, ftH ₂ O(68°F), mmAq, mmWG, mmHg or psi. |
| DP LRV (XD_SCALE of AI1) | 0 | As specified in order |
| DP URV (XD_SCALE of AI1) | Max.span | |
| DP Damping *1 | 2.00 sec | As specified in order |
| SP A/G selection | Absolute | Absolute or gauge, as specified in order |
| SP unit (XD_SCALE of AI2) | MPa | See Description for 'DP unit(XD_SCALE of AI1).' |
| SP LRV (XD_SCALE of AI2) | 0 | As specified in order |
| SP URV (XD_SCALE of AI2) | 32 | |
| SP Damping *1 | 1.00 sec | As specified in order |
| ET unit (XD_SCALE of AI3) | °C | Selectable from °C, °F or Kelvin. |
| ET LRV (XD_SCALE of AI3) | -200 | As specified in order |
| ET URV (XD_SCALE of AI3) | 850 | |
| ET Damping *1 | 1.00 sec | As specified in order |
| Fixed Temperature | 20°C (68°F) | When External Temperature Input Code 0 is specified. |
| Output signal | DP, SP, ET | When Measurement Function Code A is specified. |
| | Flow, DP, SP, ET | When Measurement Function Code B is specified. |
| Display setting | DP range and unit | When Measurement Function Code A is specified. |
| | Flow range and unit | When Measurement Function Code B is specified. |
| Node Address | '0xF5' | As specified in order |
| Operation Functional Class | 'BASIC' | As specified in order |

*1: To specify these items at factory, option code **CC** is required.

T38E.EPS

< Calibration Units >

Flow Unit Category for HART communication type

Table 9-1. Mass Flow Unit

| Unit | LCD | Communication |
|------------------------|--------|---------------|
| grams per second | g/s | ← |
| grams per minute | g/m | g/min |
| grams per hour | g/h | ← |
| kilograms per second | kg/s | ← |
| kilograms per minute | kg/m | kg/min |
| kilograms per hour | kg/h | ← |
| kilograms per day | kg/d | ← |
| metric tons per minute | t/m | t/min |
| metric tons per hour | t/h | ← |
| metric tons per day | t/d | ← |
| pounds per second | lb/s | ← |
| pounds per minute | lb/m | lb/min |
| pounds per hour | lb/h | ← |
| pounds per day | lb/d | ← |
| short tons per minute | STon/m | STon/min |
| short tons per hour | STon/h | ← |
| short tons per day | STon/d | ← |
| long tons per hour | LTon/h | ← |
| long tons per day | LTon/d | ← |

T24E.EPS

Table 9-2. Normal•Standard Volume Flow Unit

| Unit | LCD | Communication |
|--------------------------------------|--------|---------------|
| normal cubic meter per hour | Nm3/h | ← |
| normal liter per hour | NL/h | ← |
| standard cubic feet per minute | SCFM | ← |
| standard liter per hour | SL/h | ← |
| standard liter per minute | SL/m | SL/min |
| standard liter per second | SL/s | ← |
| normal cubic meter per day | Nm3/d | ← |
| standard cubic feet per day | SCFD | ← |
| standard cubic feet per hour | SCFH | ← |
| standard cubic feet per second | SCFS | ← |
| standard cubic meter per day | Sm3/d | ← |
| standard cubic meter per hour | Sm3/h | ← |
| thousand standard cubic feet per day | MSCFD | ← |
| million standard cubic feet per day | MMSCFD | ← |

T25E.EPS

Table 9-3. Volume Flow Unit

| Unit | LCD | Communication |
|-----------------------------|--------|---------------|
| cubic feet per minute | CFM | ← |
| gallons per minute | GPM | ← |
| liters per minute | L/m | L/min |
| imperial gallons per minute | IGal/m | Impgal/min |
| cubic meter per hour | M3/h | ← |
| gallons per second | gal/s | ← |
| million gallons per day | Mgal/d | ← |
| liters per second | L/s | ← |
| million liters per day | ML/d | ← |
| cubic feet per second | CFS | ← |
| cubic feet per day | ft3/d | ← |
| cubic meters per second | M3/s | ← |
| cubic meters per day | M3/d | ← |
| imperial gallons per hour | IGal/h | Impgal/h |
| imperial gallons per day | IGal/d | Impgal/d |
| cubic feet per hour | CFH | ← |
| cubic meters per minute | m3/m | m3/min |
| barrels per second | bbbl/s | ← |
| barrels per minute | bbbl/m | bbbl/min |
| barrels per hour | bbbl/h | ← |
| barrels per day | bbbl/d | ← |
| gallons per hour | gal/h | ← |
| imperial gallons per second | IGal/s | Impgal/s |
| liters per hour | L/h | ← |
| gallons per day | gal/d | ← |

T26E.EPS

Table 10. Pressure Unit

| Unit | LCD | Communication |
|-----------|---------|---------------|
| mmH2O@4C | mmH2O | ← |
| mmH2O@68F | mmH2O | ← |
| mmHg | mmHg | ← |
| Torr | Torr | ← |
| MPa | MPa | ← |
| kPa | kPa | ← |
| Pa | Pa | ← |
| mbar | mbar | ← |
| bar | bar | ← |
| gf/cm2 | gf/cm2 | ← |
| kgf/cm2 | kgf/cm2 | ← |
| inH2O@4C | inH2O | ← |
| inH2O@68F | inH2O | ← |
| inHg | inHg | ← |
| ftH2O@4C | ftH2O | ← |
| psi | psi | ← |
| atm | atm | ← |
| ftH2O@68F | ftH2O | ← |
| hPa | hPa | ← |

T27E.EPS

Table 11. Static Pressure Unit

| Unit | LCD/ Communication | When abs is selected | |
|-----------|-----------------------|----------------------|---------------|
| | | LCD | Communication |
| mmH2O@4C | mmH2O | mmH2OA | mmH2O |
| mmH2O@68F | mmH2O | mmH2OA | mmH2O |
| mmHg@0C | mmHg | mmHgA | mmHg |
| Torr | Torr | TorrA | Torr |
| MPa | MPa | MPaA | MPa |
| kPa | kPa | kPaA | kPa |
| Pa | Pa | PaA | Pa |
| mbar | mbar | mbarA | mbar |
| bar | bar | barA | bar |
| gf/cm2 | gf/cm2 | g/cm2A | g/cm2 |
| kgf/cm2 | kgf/cm2 | kg/cm2A | kg/cm2 |
| inH2O@4C | inH2O | inH2OA | inH2O |
| inH2O@68F | inH2O | inH2OA | inH2O |
| inHg@0C | inHg | inHgA | inHg |
| ftH2O@4C | ftH2O | ftH2OA | ftH2O |
| psi | psi | psiA | psi |
| atm | atm | atmA | atm |
| ftH2O@68F | ftH2O | ftH2OA | ftH2O |
| hPa | hPa | hPaA | hPa |

T28E.EPS

Table 12. Temperature Unit

| Unit | LCD/ Communication |
|--------|--------------------|
| °C | deg C |
| °F | deg F |
| Kelvin | K |

T29E.EPS

Table 13. Total Flow Unit

| Unit | LCD/Communication |
|---------------------|-------------------|
| grams | g |
| kilograms | kg |
| metric tons | t |
| pounds | lb |
| short tons | STon |
| long tons | LTon |
| ounce | oz |
| gallons | gal |
| liters | L |
| imperial gallons | Impgal |
| cubic meters | m3 |
| barrels | bbl |
| cubic yards | yd3 |
| cubic feet | ft3 |
| cubic inches | in3 |
| normal cubic meter | Nm3 |
| normal liter | NL |
| standard cubic feet | SCF |

T30E.EPS

Flow Unit Category for FOUNDATION Fieldbus communication type

Table 14. Temperature Unit

| INDEX | UNIT | LCD |
|-------|------|--------|
| 1000 | K | Kelvin |
| 1001 | °C | deg C |
| 1002 | °F | deg F |

T32E.EPS

Table 15-1. Pressure unit(1)

| INDEX | UNIT | LCD |
|-------|-------------|--------|
| 1130 | Pa | Pa |
| 1131 | GPa | GPa |
| 1132 | MPa | MPa |
| 1133 | kPa | kPa |
| 1134 | mPa | mPa |
| 1135 | μPa | uPa |
| 1136 | hPa | hPa |
| 1137 | bar | bar |
| 1138 | mbar | mbar |
| 1139 | torr | torr |
| 1140 | atm | atm |
| 1141 | psi | psi |
| 1142 | psia | psia |
| 1143 | psig | psig |
| 1144 | g/cm2 | g/cm2 |
| 1145 | kg/cm2 | kg/cm2 |
| 1146 | inH2O | inH2O |
| 1147 | inH2O(4°C) | inH2O |
| 1148 | inH2O(68°F) | inH2O |
| 1149 | mmH2O | mmH2O |
| 1150 | mmH2O(4°C) | mmH2O |
| 1151 | mmH2O(68°F) | mmH2O |
| 1152 | ftH2O | ftH2O |
| 1153 | ftH2O(4°C) | ftH2O |
| 1154 | ftH2O(68°F) | ftH2O |
| 1155 | inHg | inHg |
| 1156 | inHg(0°C) | inHg |
| 1157 | mmHg | mmHg |
| 1158 | mmHg(0°C) | mmHg |

T33E.eps

Table 15-2. Pressure unit(2)

| INDEX | UNIT | LCD |
|-------|--------------|---------|
| 1541 | Paa | Paa |
| 1542 | Pag | Pag |
| 1543 | GPaa | GPaa |
| 1544 | GPag | GPag |
| 1545 | MPaa | MPaa |
| 1546 | MPag | MPag |
| 1547 | kPaa | kPaa |
| 1548 | kPag | kPag |
| 1549 | mPaa | mPaa |
| 1550 | mPag | mPag |
| 1551 | μPaa | uPaa |
| 1552 | μPag | uPag |
| 1553 | hPaa | hPaa |
| 1554 | hPag | hPag |
| 1555 | g/cm2a | g/cm2a |
| 1556 | g/cm2g | g/cm2g |
| 1557 | kg/cm2a | kg/cm2a |
| 1558 | kg/cm2g | kg/cm2g |
| 1559 | inH2Oa | inH2Oa |
| 1560 | inH2Og | inH2Og |
| 1561 | inH2Oa(4°C) | inH2Oa |
| 1562 | inH2Og(4°C) | inH2Og |
| 1563 | inH2Oa(68°F) | inH2Oa |
| 1564 | inH2Og(68°F) | inH2Og |
| 1565 | mmH2Oa | mmH2Oa |
| 1566 | mmH2Og | mmH2Og |
| 1567 | mmH2Oa(4°C) | mmH2Oa |
| 1568 | mmH2Og(4°C) | mmH2Og |
| 1569 | mmH2Oa(68°F) | mmH2Oa |
| 1570 | mmH2Og(68°F) | mmH2Og |
| 1571 | ftH2Oa | ftH2Oa |
| 1572 | ftH2Og | ftH2Og |
| 1573 | ftH2Oa(4°C) | ftH2Oa |
| 1574 | ftH2Og(4°C) | ftH2Og |
| 1575 | ftH2Oa(68°F) | ftH2Oa |
| 1576 | ftH2Og(68°F) | ftH2Og |
| 1577 | inHga | inHga |
| 1578 | inHgg | inHgg |
| 1579 | inHga(0°C) | inHga |
| 1580 | inHgg(0°C) | inHgg |
| 1581 | mmHga | mmHga |
| 1582 | mmHgg | mmHgg |
| 1583 | mmHga(0°C) | mmHga |
| 1584 | mmHgg(0°C) | mmHgg |
| 1590 | Barg | Barg |
| 1591 | mBarg | mBarg |
| 1597 | Bara | Bara |

T34E.EPS

Table 16. Mass Flow Unit

| INDEX | UNIT | LCD |
|-------|----------|--------|
| 1318 | g/s | g/s |
| 1319 | g/min | g/m |
| 1320 | g/h | g/h |
| 1322 | kg/s | kg/s |
| 1323 | kg/min | kg/m |
| 1324 | kg/h | kg/h |
| 1325 | kg/d | kg/d |
| 1327 | t/min | t/m |
| 1328 | t/h | t/h |
| 1329 | t/d | t/d |
| 1330 | lb/s | lb/s |
| 1331 | lb/min | lb/m |
| 1332 | lb/h | lb/h |
| 1333 | lb/d | lb/d |
| 1335 | STon/min | STon/m |
| 1336 | STon/h | STon/h |
| 1337 | STon/d | STon/d |
| 1340 | LTon/h | LTon/h |
| 1341 | LTon/d | LTon/d |

T35E.EPS

Table 17. Normal•Standard Volume Flow Unit

| INDEX | UNIT | LCD |
|-------|--------|--------|
| 1360 | SCFM | SCFM |
| 1361 | SCFH | SCFH |
| 1524 | Nm3/h | Nm3/h |
| 1525 | Nm3/d | Nm3/d |
| 1529 | Sm3h | Sm3/h |
| 1530 | Sm3/d | Sm3/d |
| 1534 | NL/h | NL/h |
| 1537 | SL/s | SL/s |
| 1538 | SL/h | SL/h |
| 1539 | SL/m | SL/m |
| 1598 | MSCFD | MSCFD |
| 1599 | MMSCFD | MMSCFD |
| 65520 | SCFS | SCFS |
| 65521 | SCFD | SCFD |

T37E.EPS

Table 18. Volume Flow Unit

| INDEX | UNIT | LCD |
|-------|------------|--------|
| 1347 | m3/s | m3/s |
| 1348 | m3/min | m3/m |
| 1349 | m3/h | m3/h |
| 1350 | m3/d | m3/d |
| 1351 | L/s | L/s |
| 1352 | L/min | L/m |
| 1353 | L/h | L/h |
| 1355 | ML/d | ML/d |
| 1356 | CFS | CFS |
| 1357 | CFM | CFM |
| 1358 | CFH | CFH |
| 1359 | ft3/d | ft3/d |
| 1362 | gal/s | gal/s |
| 1363 | GPM | GPM |
| 1364 | gal/h | gal/h |
| 1365 | gal/d | gal/d |
| 1366 | Mgal/d | Mgal/d |
| 1367 | ImpGal/s | IGal/s |
| 1368 | ImpGal/min | IGal/m |
| 1369 | ImpGal/h | IGal/h |
| 1370 | ImpGal/d | IGal/d |
| 1371 | bbbl/s | bbbl/s |
| 1372 | bbbl/min | bbbl/m |
| 1373 | bbbl/h | bbbl/h |
| 1374 | bbbl/d | bbbl/d |

T36E.EPS