

# General Specifications

Model GD402  
Gas Density Meter



GS 11T3E1-01E

## Overview

The Model GD402 gas density converter and Model GD40 detector not only provide continuous measurement of gas density, but also several other valuable parameters, including specific gravity and molecular weight. The GD40 detector is designed for intrinsically safe and explosion-proof, explosion protected applications. It is designed to be virtually maintenance free for all accepted applications.

The Model GD402 is a rugged microprocessor-based converter designed in two versions to meet both general area and explosion-proof application requirements. In addition to the display of several key data items, the converter also provides the choice of three different means for calibration: automatic; semi-automatic and one-touch manual operation.

## Features

### • Proven design

Highly responsive and sensitive measurement of density. Specific gravity, molecular weight and gas concentration can also be displayed using Yokogawa's gas density analyzing techniques.

### • Detector features

1. Resistant to external vibrations.
2. Outstanding stability against sudden changes in gas temperature.
3. The multi-mode self-oscillation circuit minimizes drift caused by the sensor itself or by oil mist, dust, moisture, etc. sticking to the sensor.
4. Easy cleaning and regeneration of sensor.  
Should the sensor be contaminated with dust and/or mist, then it can be easily cleaned and returned to its original condition.
5. Only routine maintenance is required.  
(for example, once per 3 months depending on application.)

### • Simple, user-friendly interface

Configuration can be performed locally via the front panel or remotely by using the (optional) "Brain" terminal.

### • Low installation cost

Both explosion-proof and general purpose converters are designed for easy mounting on a pipe. Wiring between the detector and converter is based on a two-wire system, keeping installation cost to a minimum.



GD402G General Purpose Converter



GD402R, T, V Explosion-proof Converter

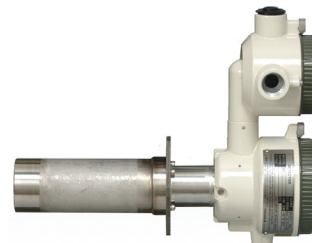

GD40G, R, T, V Detector

Certificate is approved for model GD402G, GD40G.

## 1. General Specification

### 1.1 System Components

- (1) GD40G,T,V,R detector : Rainproof for outdoor use (equivalent to IP65 / NEMA 4X)  
(see note under "2.2 Ambient condition" on page3.)  
Ambient Temperature : -10 to 60°C  
Ambient Humidity : 5 to 95%RH
- GD40G : General purpose detector. (Non Explosion-proof)  
Electrical connection : 1/2NPT female  
Process connection : 1/4NPT female
- GD40T : FM Explosion-proof and Intrinsically safe Approval.  
Explosion-proof for Class I, Division 1, Groups B, C and D;  
Dust Ignition-proof for Class II, III, Division 1, Groups E, F and G with Intrinsically Safe sensor for Class I, II, III, Division 1, Groups B, C, D, E, F and G.  
Enclosure : NEMA Type 4X  
Temperature Code : T5  
Electrical connection : 1/2NPT female  
Process connection : 1/4NPT female
- GD40V : CSA Explosion-proof and Intrinsically safe Approval.  
Explosion-proof for Class I, Division 1, Groups B, C and D;  
Dust Ignition-proof for Class II, III, Division 1, Groups E, F and G with Intrinsically Safe sensor for Class I, II, III, Division 1, Groups B, C, D, E, F and G.  
Enclosure : Type 4X  
Temperature Code : T5  
Electrical connection : 1/2NPT female  
Process connection : 1/4NPT female
- GD40R : TIIS Explosion-proof and Intrinsically safe Approval.  
Explosion-proof code : Exd [ia] IIB+H<sub>2</sub>T5  
Temperature Code : T5  
Electrical connection : G1/2 female  
Process connection : Rc1/4
- (2) GD402G, T, V, R Converter : Rainproof for outdoor use (equivalent to IP65 / NEMA 4X)  
Ambient Temperature : -10 to 55°C  
Ambient Humidity : 5 to 95%RH
- GD402G: General purpose converter. (Non Explosion-proof)  
Electrical connection : 21mm (0.9inch) in diameter. Pg13.5 cable glands included
- GD402T : FM Explosion-proof Approval.  
Explosion-proof for Class I, Division 1, Groups B, C and D;  
Dust Ignition-proof for Class II, III, Division 1, Groups E, F and G.  
Enclosure : NEMA Type 4X  
Temperature Code : T6  
Electrical connection : 1/2NPT female
- GD402V : CSA Explosion-proof Approval.  
Explosion-proof for Class I, Division 1, Groups B, C and D;  
Dust Ignition-proof for Class II, III, Division 1, Groups E, F and G.  
Enclosure : Type 4X  
Temperature Code : T6  
Electrical connection : 1/2NPT female
- GD402R : TIIS Explosion-proof Approval.  
Explosion-proof code : Exd IIB+H<sub>2</sub>T6  
Temperature Code : T6  
Electrical connection : G3/4 female
- (3) EJA310 Absolute press transmitter (optional)
- FM Explosion-proof Approval:  
Explosion-proof for Class I, Division 1, Groups B, C and D;  
Dust Ignition-proof for Class II, III, Division 1, Groups E, F and G.  
Hazardous(classified locations, indoors and outdoors (NEMA 4X)  
Temperature Code : T6  
Ambient Temperature : -40 to 60°C  
Ambient Humidity : 5 to 100%RH (at 40°C)  
Electrical connection : 1/2NPT female  
Process connection : 1/4NPT female
- CSA Explosion-proof Approval:  
Explosion-proof for Class I, Division 1, Groups B, C and D;  
Dust Ignition-proof for Class II, III, Division 1, Groups E, F and G.  
Division2 'SEALS NOT REQUIRED'  
Enclosure : Type 4X  
Temperature Code : T4, T5, T6  
Max. Process Temp.: T4 120°C, T5 100°C, T6 85°C  
Ambient Temperature : -40 to 80°C  
Ambient Humidity : 5 to 100%RH (at 40°C)  
Electrical connection : 1/2NPT female  
Process connection : 1/4NPT female
- TIIS Explosion-proof Approval:  
Explosion-proof code : Ex do IIC T4X  
Temperature Code : T4  
Ambient Temperature : -20 to 60°C  
Ambient Humidity : 5 to 100%RH (at 40°C)  
Electrical connection : G1/2 female  
Process connection : Rc1/4

**1.2 Characteristics**

**GD402 specification list**

Item	Density kg/m <sup>3</sup>	Density lb/ft <sup>3</sup>	Specific Gravity	Molecular Weight	Concentration vol%
Range	0 - 6 (compensated) 0 - 60 (physical)	0 - 0.4 (compensated) 0 - 4 (physical)	0 - 5	0 - 140	0 - 100
Minimum Range	0.1	0.01	0.1	4	Concentration equivalent to 100 kg/m <sup>3</sup>
Response Time 90%	approx. 5 sec	approx. 5 sec	approx. 5 sec	approx. 5 sec	approx. 5 sec
Linearity	+/- 1 % FS	+/- 1 % FS	+/- 1 % FS	+/- 1 % FS	+/- 1
Repeatability	+/- 0.001 or +/-0.5%FS *	+/- 0.0001 or +/-0.5%FS*	+/- 0.001 or +/-0.5%FS*	+/- 0.02 or +/-0.5%FS*	+/- 0.5% or Concentration equivalent to +/-0.001kg/m <sup>3</sup> *
Long term stability	+/- 0.003/month	+/- 0.002/month	+/- 0.003/month	+/- 0.07/month	Concentration equivalent to +/- 0.003 kg/m <sup>3</sup> /month

\*: Whichever is greater

**Density is the basic measurement, the other representations are derived from the Density data.**

Item	H <sub>2</sub> in Air vol%	H <sub>2</sub> in CO <sub>2</sub> vol%	Air in CO <sub>2</sub> vol%	Caloric value MJ/m <sup>3</sup>	British Thermal Unit KBTU/ft <sup>3</sup>
Range	85 - 100	0 - 100	0 - 100	0 - 130	0 - 3.5
Minimum Range	—	—	—	Caloric value equivalent to 0.100 kg/m <sup>3</sup>	Caloric value equivalent to 0.100 kg/m <sup>3</sup>
Response Time 90%	approx. 5 sec	approx. 5 sec	approx. 5 sec	approx. 5 sec	approx. 5 sec
Linearity	+/- 1	+/- 1	+/- 1	+/- 1 % FS	+/- 1 % FS
Repeatability	+/- 0.5	+/- 0.5	+/- 0.5	+/- 0.5%FS or Caloric value equivalent to 0.001kg/m <sup>3</sup> *	+/- 0.5%FS or Caloric value equivalent to 0.001kg/m <sup>3</sup> *
Drift	+/- 0.5/month	+/- 0.5/month	+/- 0.5/month	Caloric value equivalent to +/- 0.003kg/m <sup>3</sup> /month	Caloric value equivalent to +/- 0.0025/month

Caloric Value and BTU are possible representations of the Density. GD402 does not contain table information, only a single mathematical equation.

\*: Whichever is greater

**1.3 Output Signals**

- Output 1: 4-20 mA DC  
Isolated from inputs; load resistance: 600Ω maximum  
(Load resistance of 250-550Ω required when in the BRAIN communication mode)
- Output 2: 4-20 mA DC  
Isolated from inputs; load resistance: 600Ω maximum

**1.4 Power Supply**

- Rated voltage range: 100 to 240 V AC, 24V DC
- Allowable voltage range: 85 to 264 V AC, 21.6 to 26.4V DC
- Rated frequency: 50 or 60 Hz
- Allowable frequency range: 47 to 63 Hz

**1.5 Power Consumption**

Approximately 12 W.

**1.6 Sample gas conditions**

- Sample gas: All gases except for corrosive gas and acetylene gas
- Temperature: -10 to 50°C (non-condensing)
- Pressure: Max. 588.5kPa (abs)
- Gas flow: 0.1 to 1 l/min

**1.7 Safety and EMC Compliance**

- Safety Standards: EN61010-1
- EMC Standards: (Applied only when GD402G converter is used with GD40G detector.)  
Emission: EN61326 Class A  
EN61000-3-2  
EN61000-3-3  
AS/NZS CISPR11
- Immunity: EN61326 Annex A and F
- Korea Electromagnetic Conformity Standard

## 2. GD40G,T,V,R Detector

### 2.1 Material exposed to gas

SUS316 stainless steel, Acrylonitrile Butadiene Rubber and Fluorine-contained Rubber (o-ring)

### 2.2 Ambient conditions

Temperature: -10 to 60°C (14 to 140°F)

Humidity: 5 to 95% RH

Installation: Pipe-mounted or on panel

Construction: Intrinsically safe, Explosion-proof

Though the detector construction makes it relatively insensitive to sudden changes in the gas temperature, extra precision can be achieved by keeping ambient temperature conditions as constant as possible. In measurements where optimum precision is required it is therefore not recommended to install the detector in an outdoors environment, especially not if such installation is prone to direct sunlight.

### 2.3 Finish

Cover: equivalent to Munsell 0.6GY3.1/2.0

Case: equivalent to Munsell 2.5Y8.4/1.2

### 2.4 Weight

Approx. 7 kg (with Pipe-mounting Bracket)

### 2.5 Detector unit

When the system is ordered to be used as a hydrogen purity analyzer an optional pressure analyzer is required for pressure compensation.

- If /EJAJ1□, /EJAF2□/EJAF3□ or EJAF4□ are ordered, the detector unit and the pressure transmitter and the tubing in between will all be integrated on a single mounting plate. This allows the space where the pressure transmitter is normally mounted to be used effectively for other purposes.

## 3. GD402G,T,V,R Converter

### 3.1 Display

Reading: Digital(5 digits maximum)

Data items shown:

Measured value:Always on display.

Alarm indications:Abnormal concentration, abnormal pressure range of input and abnormal values of calibration

Parameters for calibration:

Time of calibration, settling time, starting time of calibration and calibration cycle

Self-diagnostic indications:

Sensor oscillation shutdown, abnormal oscillation frequency of sensor, failure in sensor temperature detection, failure in A/D conversion stage and memory failure

Alarm settings:The contact state can be set to either "normally open (NO)" or "normally closed (NC)" depending on the needs of the application.

Temperature:Temperature of gas being measured

### 3.2 Contact Outputs/Input

Contact output:

Signals for Maintenance, Fail, Hi/Lo alarms

Contact capacity:250 V AC at 3A or 30 V DC at 3A

Contact input:

Signal for switching between the Hydrogen Purity meter and the Replacement meter

### 3.3 Calibration

Manual (one touch), Semi automatic, Automatic calibration

### 3.4 Communication

Protocol: BRAIN communication

Data items that can be transmitted by the hand-held terminal are numerical data, such as concentration, temperature and pressure, alarm setpoint and self-diagnostic parameters.

### 3.5 Ambient Conditions

Temperature:-10 to 55°C (14 to 131°F)

Humidity: 5-95% RH

### 3.6 Installation

Non-explosion-proof models:

Pipe-, panel- or wall-mounted

Explosion-proof models:

Pipe-mounted

### 3.7 Finish

Model GD402G (general purpose):

Front cover:equivalent to Munsell 0.6GY3.1/2.0

Case:equivalent to Munsell 2.5Y8.4/1.2

Model GD402R, T, V (explosion-proof):

equivalent to Munsell 0.6GY3.1/2.0

### 3.8 Weight

Model GD402G (general purpose):approx. 3 kg (6.6 pounds)

Model GD402T, V, R (explosion-proof):approx. 15 kg (33.1 pounds)

## MODEL and SUFFIX CODES

### 1. Gas Density Converter

Model	Suffix code	Option code	Description
GD402G	-----	-----	General purpose model, 6 cable glands included.
GD402T	-----	-----	FM certified explosion proof model. Gland threads 1/2NPT. No cable glands included.
GD402V	-----	-----	CSA certified explosion proof model. Gland threads 1/2NPT. No cable glands included.
GD402R	-----	-----	TIIS certified explosion proof model. Gland threads G3/4. No cable glands included.
Power supply	-D -A	-----	24V DC 100-240V AC
Label and approval	-E -J	-----	English label TIIS approval, English label (only GD402R)
Instruction Manual	-E	-----	English
Options (only GD402G)		/PA /U /H	Panel mounting Universal (Pipe and Wall) Mounting Hood

[Note] Explosion-proof models, GD402T, V, R have only pipemounting hardware as standard.

#### ■ GD402□ Standard Accessory List

Model	Item	Qty	Part Number
GD402G	Fuse	1	A1109EF (Power Supply: 100-240 V AC) A1111EF (Power Supply: 24 V DC)
	Universal Mount Set	1	K9171SS
	Panel Mount Set	1	K9171ST
	Surge Protector	1	K9215LP
GD402R GD402T GD402V	Fuse	1	A1109EF (Power Supply: 100-240 V AC) A1111EF (Power Supply: 24 V DC)
	Bracket	1	K9214HD
	Bracket	1	K9214HE
	U-Bolt Assy	2	D0177XL-A
	Bolt	1	Y9835NU
	Bolt	2	Y9820NU

### 2-1. Gas Density Detector

Model	Suffix code	Option code	Description
GD40G	-----	-----	General purpose detector. 1/4NPT gas threads and 1/2NPT gland threads. No cable gland included. Mounting hardware included.
GD40R	-----	-----	TIIS certified explosion proof detector. Rc1/4 gas threads and G1/2 gland threads. Cable gland included. Mounting hardware included.
Label approval	-E -J	-----	English label, no approval (only GD40G) TIIS approval, English label (only GD40R)
Options		/EJAJ1 /EJAJ1T /EJAF2 /EJAF2T	TIIS certified EJA mounted with detector on mounting plate. Rc1/4 gas threads and G1/2 gland thread. Cable gland included.(only GD40R) TIIS certified EJA mounted with detector on mounting plate. Rc1/4 gas threads and G1/2 gland thread. Cable gland included. EJA with TAG (only GD40R) EJA mounted with detector on mounting plate.1/4NPT gas threads and 1/2NPT gland threads. No cable gland included.(only GD40G) EJA mounted with detector on mounting plate.1/4NPT gas threads and 1/2NPT gland threads. No cable gland included. EJA with TAG (only GD40G)

**2-2. Gas Density Detector**

Model	Suffix code	Option code	Description
GD40T	-----	-----	FM certified explosion proof detector. 1/4NPT gas threads and 1/2NPT gland thread. No cable gland included. Mounting hardware included
GD40V	-----	-----	CSA certified explosion proof detector. 1/4NPT gas threads and 1/2NPT gland thread. No cable gland included. Mounting hardware included.
Options		/EJAF3	FM certified EJA mounted with detector on mounting plate. 1/4NPT gas threads and 1/2NPT gland thread. No cable gland included. (only GD40T)
		/EJAF3T	FM certified EJA mounted with detector on mounting plate. 1/4NPT gas threads and 1/2NPT gland thread. No cable gland included. EJA with TAG (only GD40T)
		/EJAF4	CSA certified EJA mounted with detector on mounting plate. 1/4NPT gas threads and 1/2NPT gland thread. No cable gland included. (only GD40V)
		/EJAF4T	CSA certified EJA mounted with detector on mounting plate. 1/4NPT gas threads and 1/2NPT gland thread. No cable gland included. EJA with TAG (only GD40V)

**■ GD40□ Standard Accessory**

Item	Qty	Part Number
U-Bolt Assy*1	4	D0177XL-A
Bracket*1	1	K9214HD
Bracket*1	1	K9214HE
Gland*2	1	G9601AM

\*1: Not supplied when option code "/EJAJ1□", "/EJAF2□", "/EJAF3□" or "/EJAF4□" is specified.

\*2: Supplied only for GD40R.

**3. Hardware for Connection with External Cables (For Explosion-Proof use)**

Part No.	Description
L9811LL	G3/4 explosion proof cable gland. Cable's outside diameter 8 to 16 mm. Used for the GD402R converter.

Note: Specify the number of cable glands for converter in hazardous area.

**4. Two-Core, Double-Shielded Cable**

Normally two conductor shielded cable can be used, but when failure arises from noises disturbance, this cable is recommended for connection between the GD402 converter and GD40 detector.

Model	Basic code	Description
GDW	-----	Two core, double shielded cable, both ends finished with cable pins.
Length	-L□□□	Length in meters, 500 meter maximum.

**5. Brain Terminal (Optional)**

Model	Suffix code	Option code	Description
BT200	-----	-----	Brain terminal [Note]
Printer	-N	-----	Standard type (without printer)
	-P	-----	With printer
—	00	-----	Always 00
Options		/□□	

[Note] BT200 has following accessories, two communication cables, one with IC clips and another with alligator clips, handy carrying case and five AA 1.5 V dry batteries.

**OPTIONS FOR BT200**

Options	Description	Option codes
Communication cable(Note 1)	With a 5-pin connector(for the signal conditioner)	/C1
Intrinsically safe type (Note 1)(Note 2)	CSA Intrinsically safe approval Class I, Groups A, B, C and D Temp.Code:T4	/CS1

(Note 1) Optional code /C1 can not be combined with/CS1.  
 (Note 2) Applicable only for Model BT200-N00.

See GS 1C0A11-E for "BT200" brain terminal in detail.

**6. Pressure transmitter (optional)**

/EJAJ1□ means TIIS certified EJA310.  
 /EJAF2□ means general purpose model EJA310.  
 /EJAF3□ means FM certified EJA310.  
 /EJAF4□ means CSA certified EJA310.

See GS 01C22D01-00E for "EJA310" pressure transmitter in detail if a different selection from pre-selected options seems necessary.

### ■ System Configuration

(for wiring, see Instruction Manual IM11T3E1-01E.)

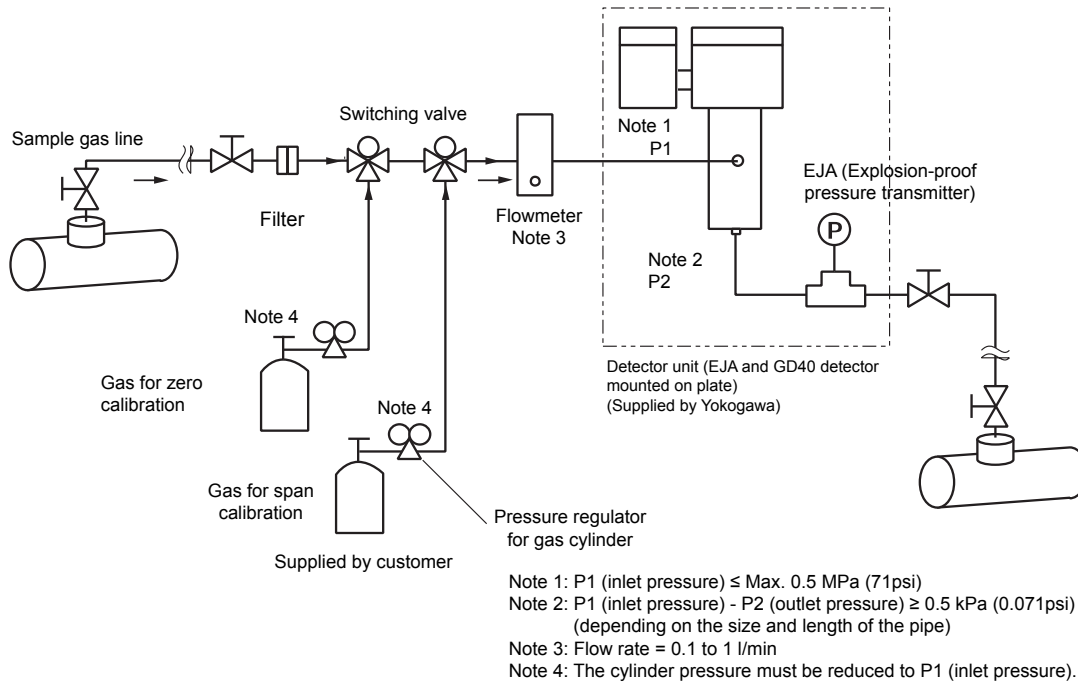
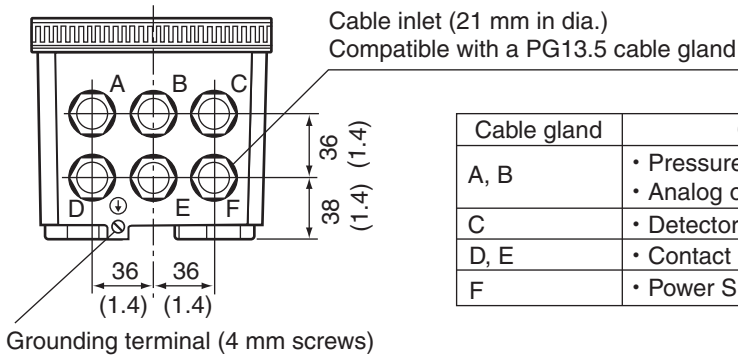
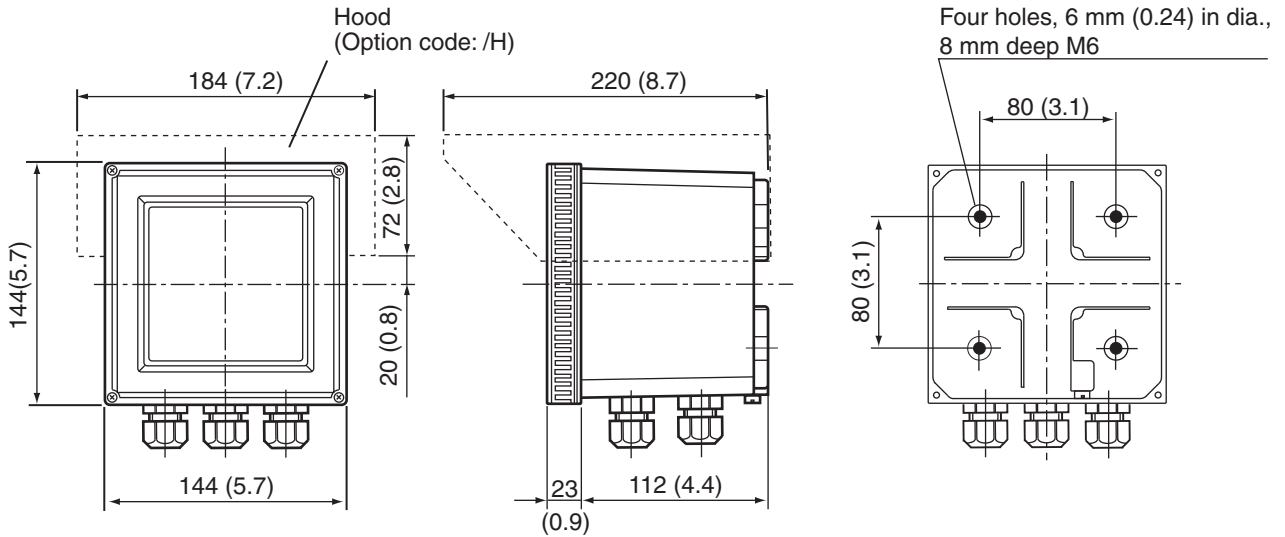

Fig 5-04.ai

**EXTERNAL VIEWS AND DIMENSIONS**

**1. GD402G Converter (Non-Explosion-Proof):**

Unit: mm(in.)



Cable gland	Connection
A, B	• Pressure transmitter • Analog output • Contact Input
C	• Detector
D, E	• Contact Output
F	• Power Supply

Weight : Approx. 3kg (6.6pounds)  
(including mounting hardware)

**2. Pipe and Wall-Mounting Hardware (Optional)**

- Hardware for Pipe Mounting (Option code /U)

Unit : mm (in.)  
Weight : Approx. 3kg

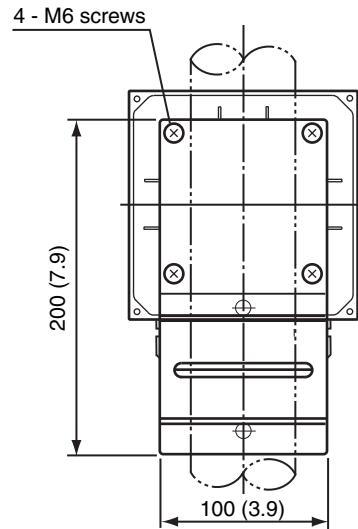
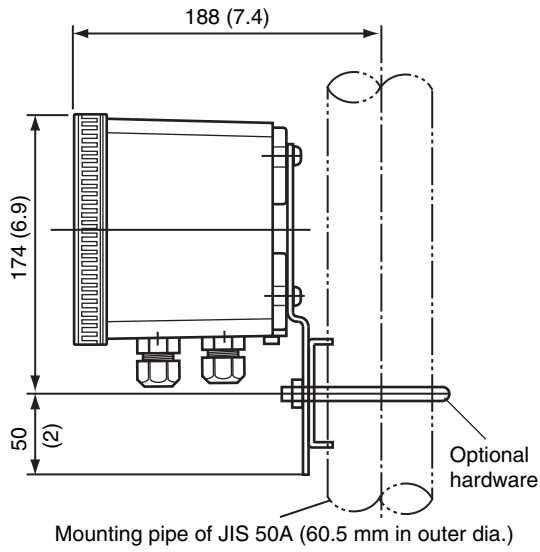

- Hardware for Wall Mounting (Option code /U)

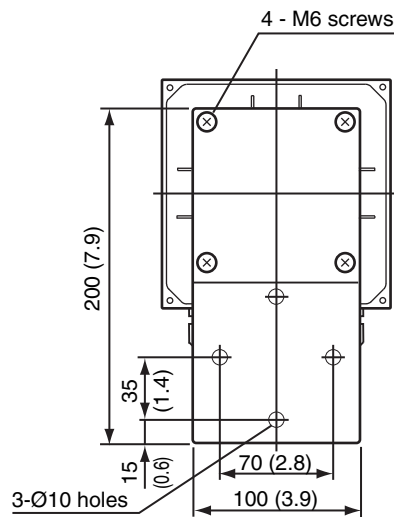
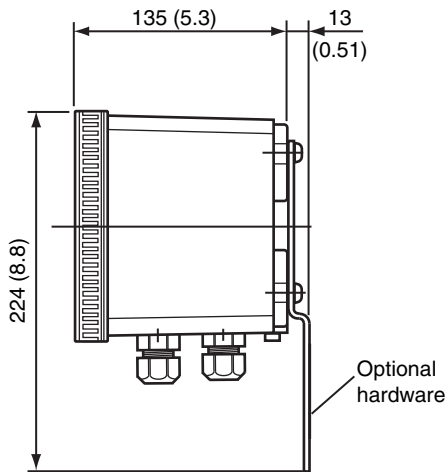

- Hardware for Panel Mounting (Option code /PA)

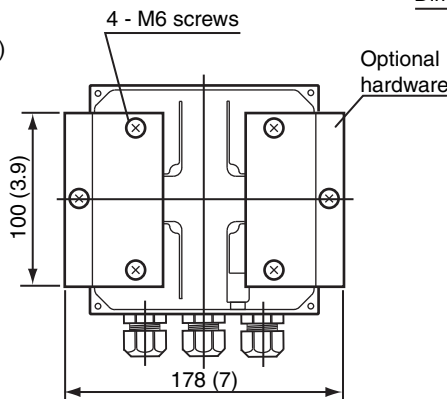
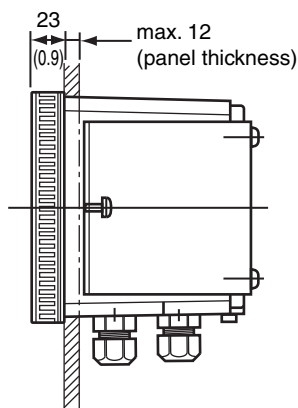

Dimensions of panel cutout

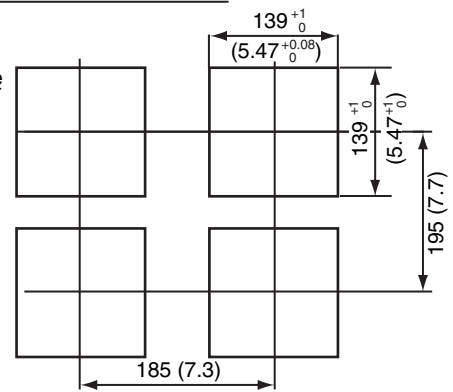

3. GD402T, V, R Converter (Explosion-proof)

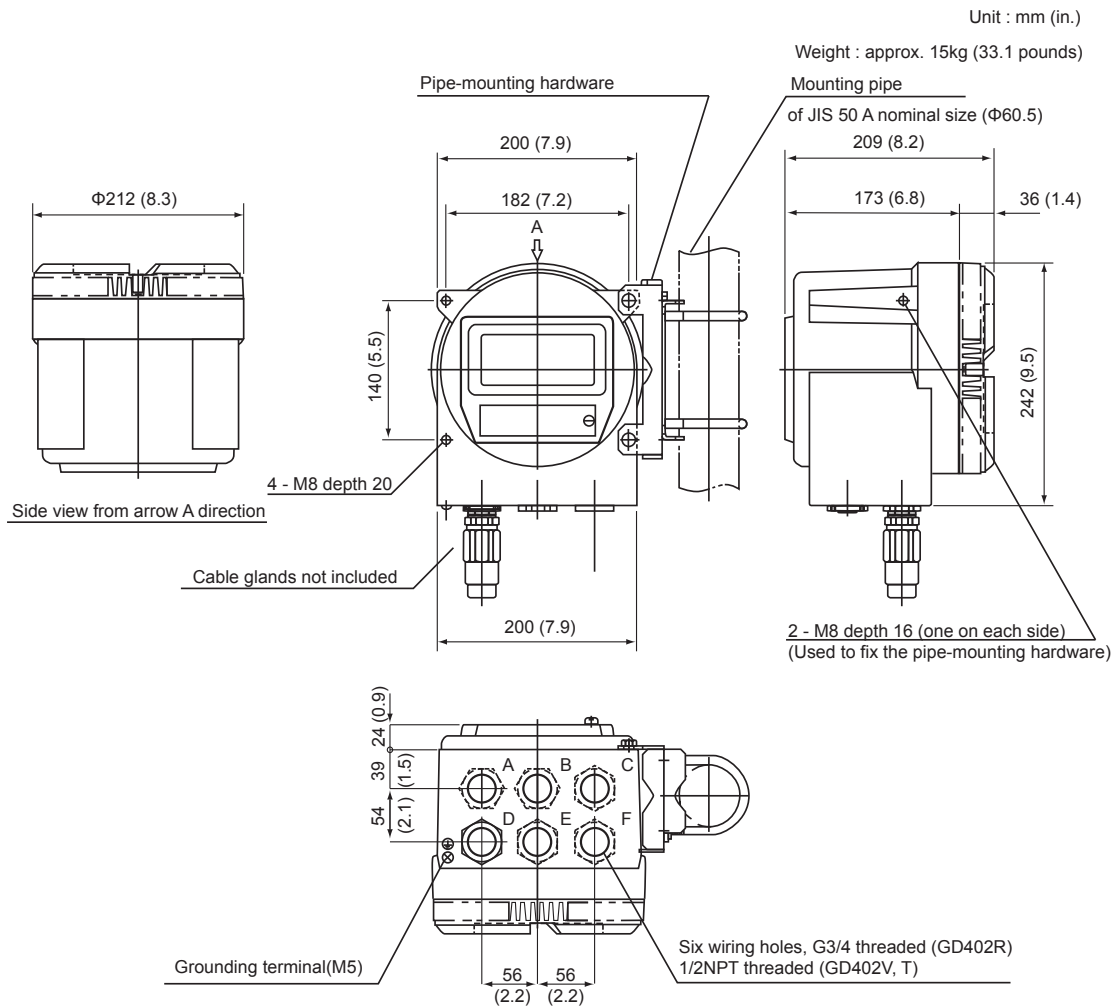

Cable gland	Connection
A	• Power Supply
B, C	• Contact Output
D	• Detector
E, F	• Pressure from Transmitter • Analog Output • Contact Input

### 4. Detector Unit

- Model GD40□-□/EJAJ1□, EJAF2□, EJAF3□, EJAF4□

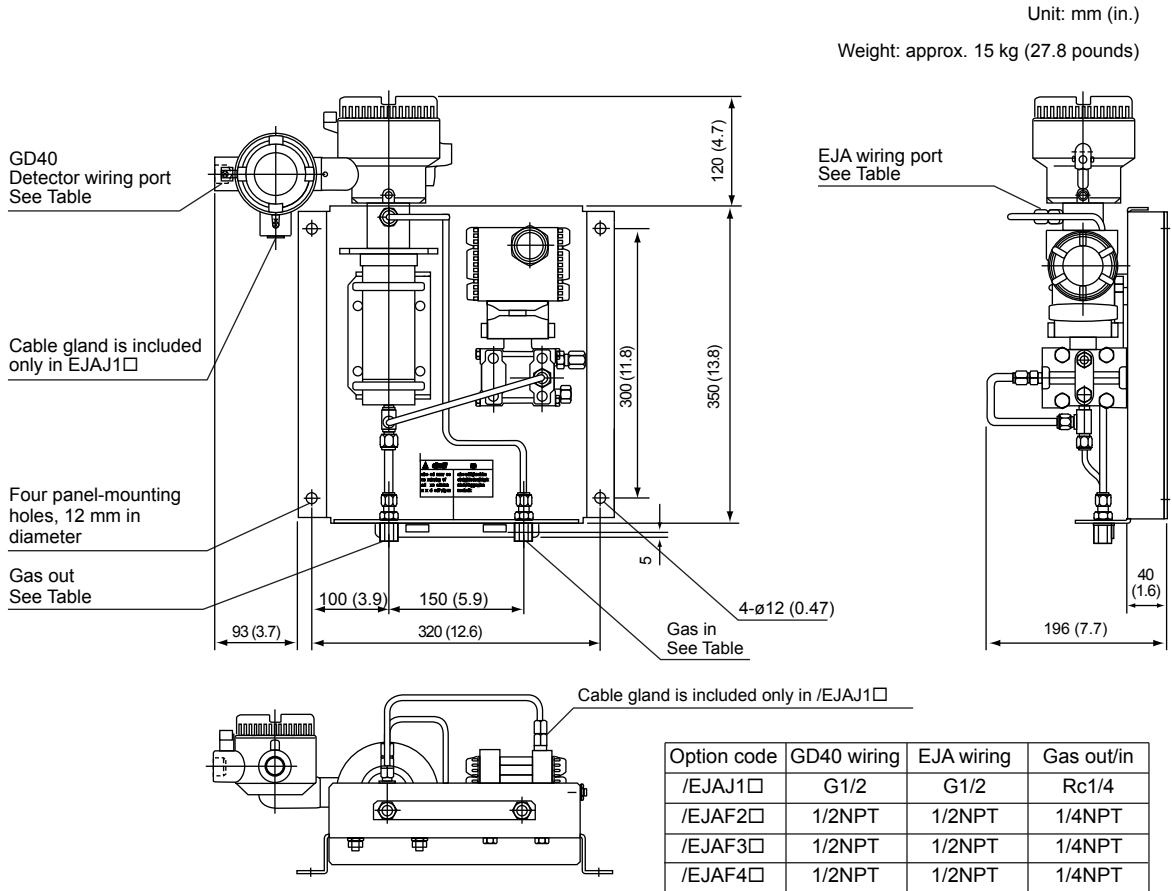

### 5. GD40□ Detector

- Hardware for Pipe Mounting: GD40□

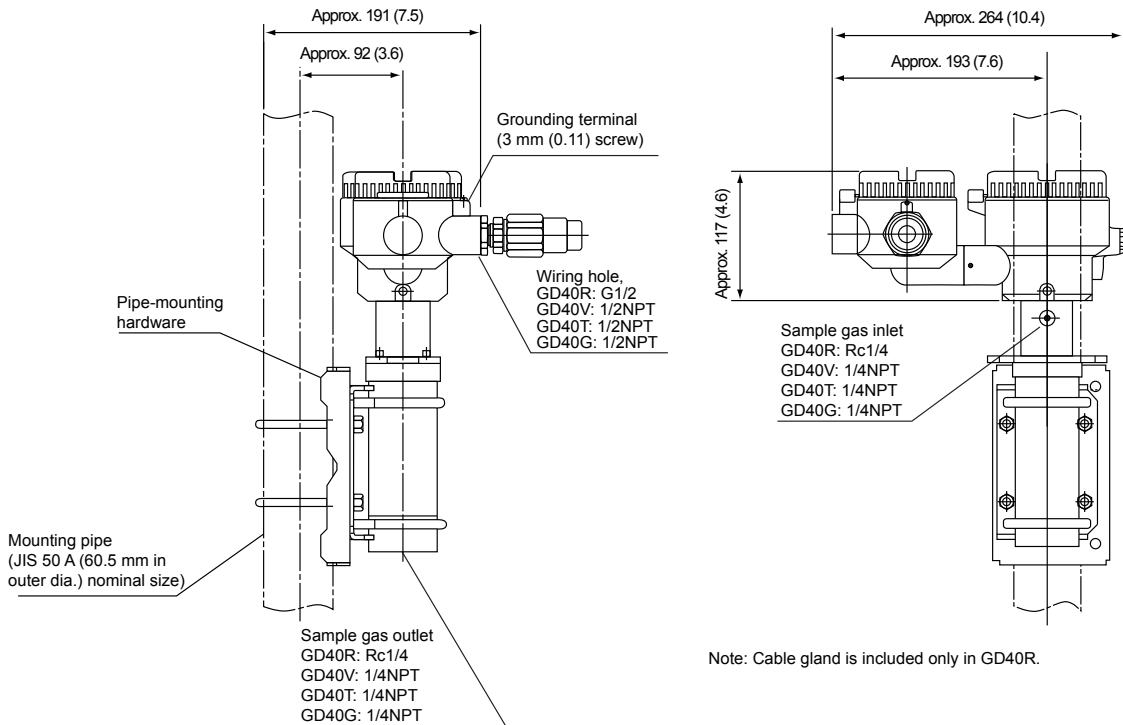

### 6. Surge protector

Unit: mm (In.)

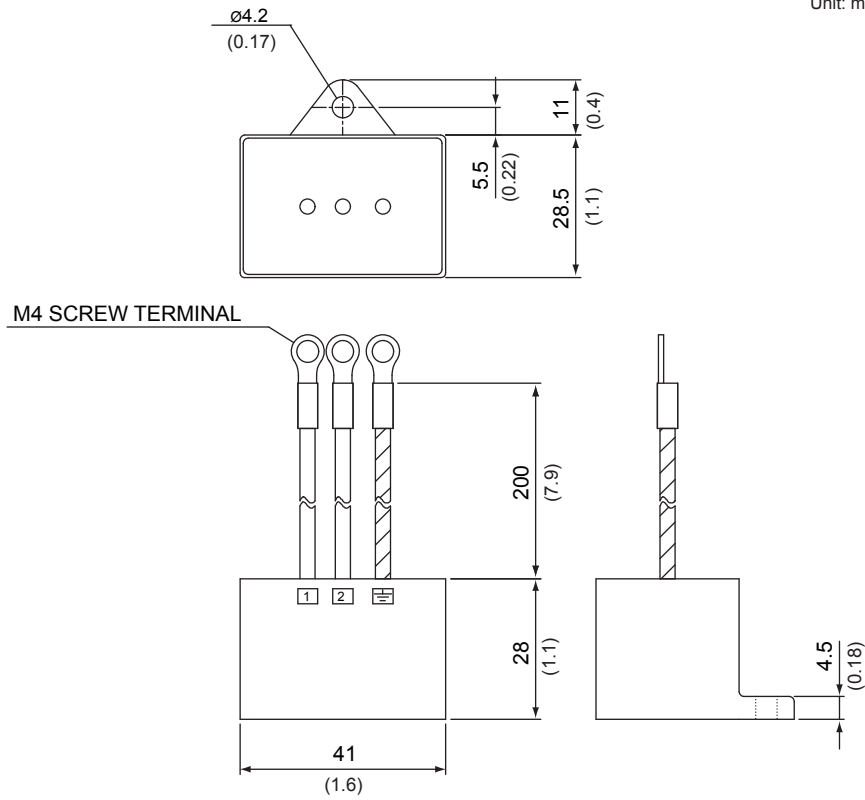

**WIRING DIAGRAM**

(See Instruction Manual IM11T3E1-01E for details on cable installation.)

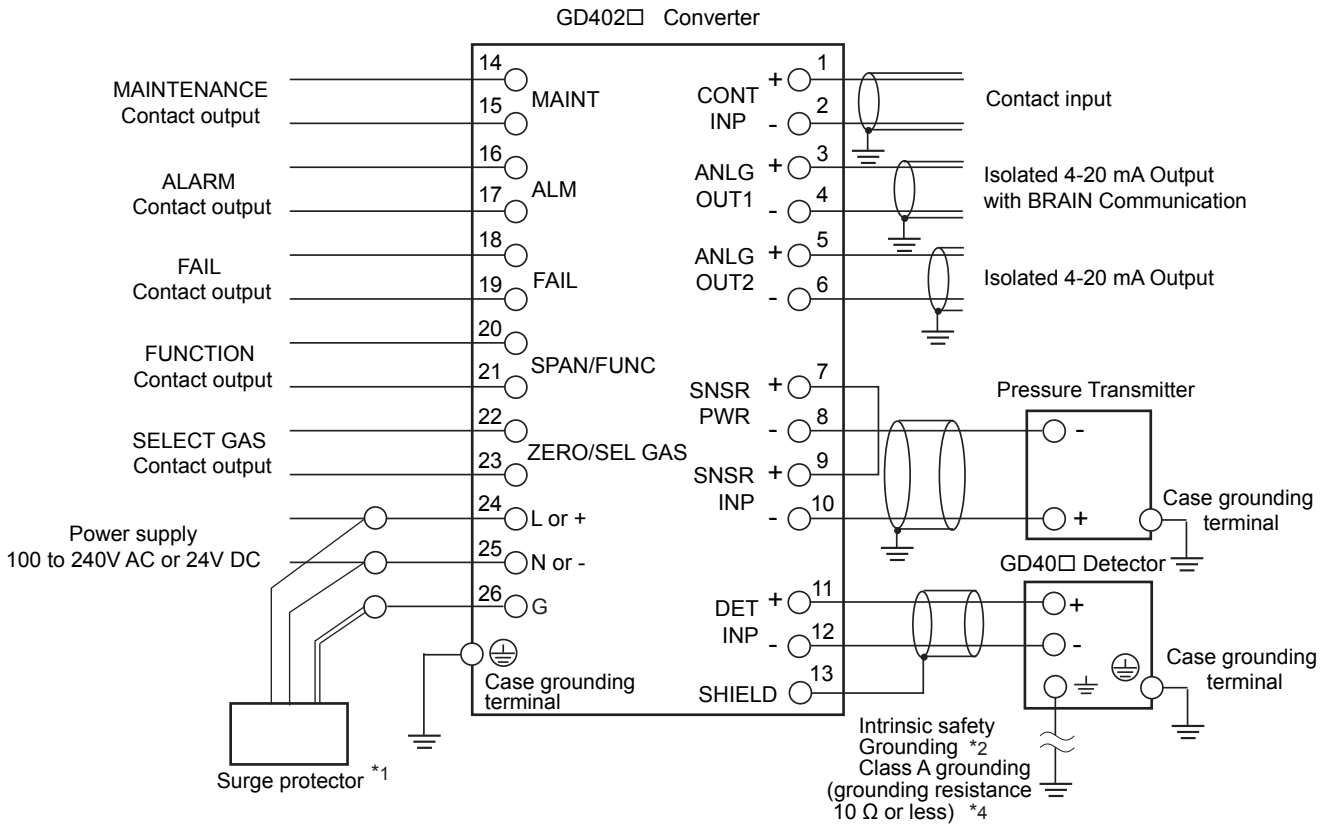

Cable List

Terminal	Indication	Shield Requirement	Requirement
MAINTENANCE Contact output	MAINT	Unshielded	
ALARM Contact output	ALM	Unshielded	
FAIL Contact output	FAIL	Unshielded	
FUNCTION Contact output	SPAN	Unshielded	
SELECT GAS Contact output	ZERO	Unshielded	
Contact input	CONT IN	Shielded	For outdoor wiring, cable length should be less than 30 m *3 . Shield should be grounded at one end only.
Analog output1	ANLG OUT1	Shielded	Total resistance should not exceed 50 Ω. For outdoor wiring, cable length should be less than 30 m *3 . Shield should be grounded at one end only.
Analog output2	ANLG OUT2	Shielded	Maximum load resistance including wire resistance is 600Ω . When BRAIN communication is used, it is 250 to 550 Ω.
Pressure transmitter input	SNSR PWR SNSR INP	Shielded	Total resistance should not exceed 50 Ω. For outdoor wiring, cable length should be less than 30 m *3 . Shield should be grounded at one end only.
Detector input	DET INP SHIELD	Shielded	Total resistance should not exceed 50 Ω. For outdoor wiring, cable length should be less than 30 m *3 . Connect shield to SHIELD terminal on converter.
Supply	L, N, G	Unshielded	

\*1 Surge protector is not provided with GD402T/V/R type converter.

\*2 Intrinsic safety grounding

GD402V, GD40V; All wiring should comply with Canadian Electrical Code and Local Electrical Codes.  
GD402T, GD40T; All wiring should comply with National Electrical Code and ANSI/NFPA 70 and Local Electrical Codes.

\*3 Restriction on cable length does not apply to GD402T/V/R type converter.

\*4 When select GD402T/V/R.

The following instructions should be observed for the GD402G converter to meet the CE marking requirements.

1. Connect the supplied surge protector to the power supply.
2. The length of the following cables should be less than 30 m. However, this restriction does not apply when both detector and converter stay indoors and their cables do not run outdoors.
  - 1) Detector input
  - 2) Pressure transmitter input
  - 3) Analog output1, 2
  - 4) Contact input

Contact Input Function of the Hydrogen Purity Meter

For hydrogen purity meter, the contact input is used for range selection.

- Open: Concentration measurement for air in carbon dioxide
- Close: Concentration measurement for hydrogen in carbon dioxide

Contact Output Specifications

	<b>Specification</b>
MAINT	Contact Type: Voltage free, dry contact (mechanical relay contact output) Contact rating: 250 V AC 3A or 30 V DC 3A Contact arrangement: NO/NC, selectable
ALM	
FAIL	Contact Type: Voltage free, dry contact (mechanical relay contact output) Contact rating: 250 V AC 3A or 30 V DC 3A Contact arrangement: NC, fixed
SPAN/FUNC	Function contact; use distinguish between the Hydrogen purity meter and the Replacement meter. Select gas contact; use distinguish measuring ranges in Replacement meter. Contact Type: Voltage free, dry contact (mechanical relay contact output) Contact rating: 250 V AC 3A or 30 V DC 3A Contact arrangement: NO/NC, selectable
ZERO/SEL GAS	

GD402 Gas Density Meter Inquiry Form

**1. General**

Customer : \_\_\_\_\_  
 : \_\_\_\_\_  
 Tag No. : \_\_\_\_\_  
 : \_\_\_\_\_  
 Plant name : \_\_\_\_\_  
 : \_\_\_\_\_  
 Measuring point : \_\_\_\_\_  
 : \_\_\_\_\_  
 Purpose of use:  Monitoring  Control  Alarm  
 Transaction  Other  
 Quantity to be measured:  
 Density,  Specific gravity,  
 Molecular weight,  Caloric value  
 BTU,  H<sub>2</sub> in Air,  Air in CO<sub>2</sub>  
 H<sub>2</sub> in CO<sub>2</sub>,  Concentration  
 Measuring range: \_\_\_\_\_  
 Document :  English

**2. Utilities and Installation Conditions**

Power supply :  \_\_\_ VAC \_\_\_ % \_\_\_ Hz \_\_\_ %  
 \_\_\_ 24VDC  
 Instrument air : Pressure \_\_\_\_\_  psi,  Pa  
 Steam supply : Pressure \_\_\_\_\_  psi,  Pa  
 Temperature \_\_\_\_\_  °C,  °F  
 Cooling water : Pressure \_\_\_\_\_  psi,  Pa  
 Temperature \_\_\_\_\_  °C,  °F  
 Distance between gas sampling point and analyzer:  
 \_\_\_\_\_ m

**3. Process Conditions**

Gas component(s) : Refer to blew list.  
 Pressure at gas sampling point : \_\_\_\_\_  psi,  kPa  
 Temperature at gas sampling point : \_\_\_\_\_  °C,  °F  
 Quantity of dust : \_\_\_\_\_ g/m<sup>3</sup>  
 Moisture :  \_\_\_ vol%  
 :  \_\_\_ °C,  °F saturated  
 Corrosiveness :  \_\_\_ No  \_\_\_ Yes

**4. Installation Conditions**

Temperature: \_\_\_  °C Maximum, \_\_\_  °F Minimum,  
 Corrosive gas:  No  Yes \_\_\_\_\_  
 Vibration :  No  Yes \_\_\_\_\_  
 Location :  Indoors  Outdoors

**5. Other Specific Items**

\_\_\_\_\_  
 \_\_\_\_\_  
 \_\_\_\_\_  
 \_\_\_\_\_  
 \_\_\_\_\_

**6. Scope of Estimation**

Converter \_\_\_\_\_ units  
 Non-explosion-proof  
 Explosion-proof  
 Detector \_\_\_\_\_ units  
 Gas sampling system (special order) \_\_\_\_\_ sets  
 Others \_\_\_\_\_ sets

Gas component (s)	Concentration (vol%)			Density
	Nor.	Max.	Min.	
1				
2				
3				
4				
5				
6				
7				
8				
9				
10				
11				
12				

**Notes**

\_\_\_\_\_  
 \_\_\_\_\_  
 \_\_\_\_\_