

# General Specifications

## Model PH202G 2-Wire Type pH/ORP (Redox) Transmitter

EXA PH

GS 12B07D02-E

### GENERAL

Flexibility, low maintenance and low installation costs are among the benefits of the EXA PH202 pH/ORP transmitter. Designed to meet the exacting requirements of measuring pH and ORP in the modern industrial environment, it contains many features to ensure peak precision whatever the application.

This 2-wire (loop powered) transmitter is housed in a robust IP65 field mountable case. HART® communication is also available. The need for expensive cabling is minimized. The famous EXA sensor diagnostics are enhanced by an improved impedance check, and the addition of a logbook feature. Calibration history is available in the display, and is used to store important configuration, calibration and diagnostic data. Prediction of sensor failure is possible by reference to the logbook.

Microprocessor-aided calibration uses internal buffer tables and stability checking to ensure maximum accuracy with minimum effort. Process temperature compensation enhances accuracy in applications where the influence of temperature is seen in process pH changes. pH and ORP or rH measurements can be made simultaneously when an appropriate sensor combination is used.



### FEATURES

- Universal pH/ORP
- Possible to input high impedance reference electrode
- On-line sensor checking
- Process temperature compensation
- Differential input amplifier with equipotential screening
- Freely configurable ITP, slope and asymmetry
- Easy to use EXA control panel
- Password protection for all levels of software
- HART®, PROFIBUS-PA, FOUNDATION Fieldbus H1 communications

## ACCURATE pH MEASUREMENT

### 1. Electrode selection

In order to make precise pH/ORP measurements, there are a number of pre-requisites. Special attention should be paid to the choice of the sensors to ensure compatibility with the chemical composition of the process fluid. The speed of response required, the solids content and the flow rate of the fluid are also contributory factors. The GS12B07B02 -E general specifications cover the choice of sensors.

### 2. Signal processing (pH/ORP)

With the correct sensor configuration, the PH202 can measure pH and ORP.

### 3. High performance transmitter

The PH202 provides excellent noise rejection, minimizing the stray signals that can affect industrial pH measurements. Earth loop currents in damp and damaged cabling are eliminated by the equipotential screening. It offers a simple and effective process temperature compensation in addition to the usual compensation to the Nernst equation.

### 4. Maintenance

It is important that the system be well maintained to make precise pH/ORP measurement. The electrodes must be properly cleaned and regularly calibrated. Yokogawa on-line cleaning systems may be used where there is significant fouling of the sensors. Other influences from the electrode holders can be less obvious, but important none the less. Well designed fittings make it easy to provide the routine maintenance needed for best accuracy. Flow-through submersion, suspension and float types of holders are available.

## HART COMMUNICATION

One of the features of smart field devices is their ability to detect faults, either in the device electronics or in an associated sensor. Using a fieldbus system, such faults are reported in the device status byte in every message (assuming that communication is still possible!). For HART, it is still useful to follow the convention of indicating fault conditions by setting the analogue output current to a value which is recognizably beyond the normal operating range (including the small amount of linear over-range commonly allowed). If it is still alive, the current output value is set to an appropriate value with the intention that a host system should be able to set alarm thresholds just outside the normal 4 to 20 mA range, to indicate measurement out-of-range, and to set further alarm thresholds to indicate a fault condition.

### DD specification and other support files

The PH202 Device Description (DD) files are available enabling communications compatible HOST devices (and HHT for HART). Other files to support AMS, PRM and PDM are available as well.

## PROCESS TEMPERATURE COMPENSATION

The figure below shows the strong change in pH with temperature, caused by the dissociation constant of water changing. This effectively shifts the neutral point from pH7. In order to reliably control the pH of solutions it is necessary to compensate for the changes. The PH202 transmitter has a simple-to-operate system of process temperature compensation to provide optimum accuracy and best control. An application where this is particularly important is in the measurement of alkalized boiler feed water.

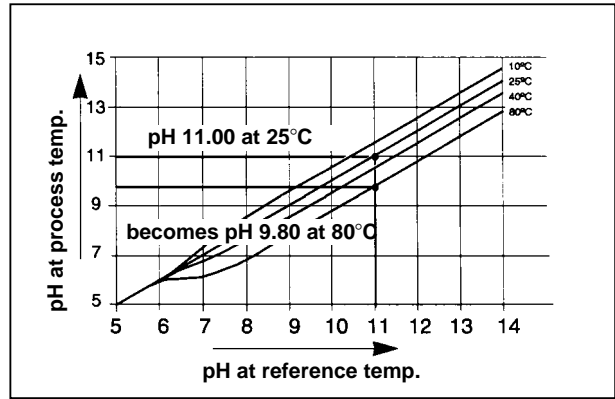

F2.EPS

## 3-LEVEL OPERATION

The PH202 transmitter uses a 3-level operating system to take full advantage of the microprocessor while retaining the traditional simplicity of a 2-wire transmitter. Advanced functions are separated from conventional operation to avoid confusion. They can be activated as required for each individual application.

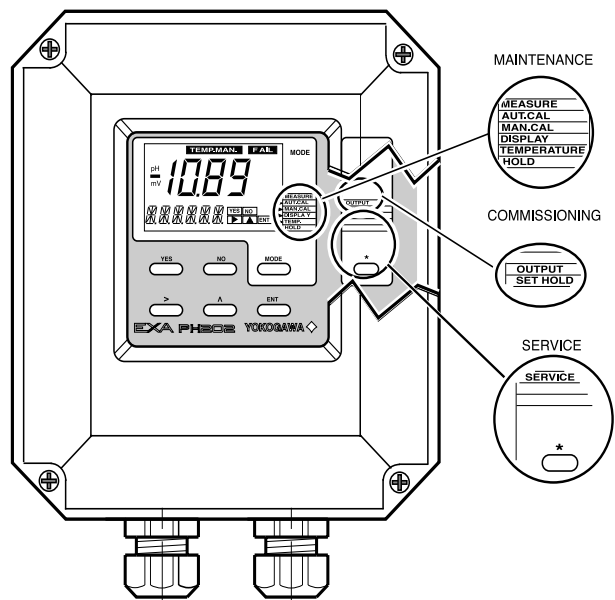

## MAINTENANCE level

The normal maintenance functions are accessible through the flexible window by pushing the keys underneath.

Use : Normal operation and checking

How : Simple operation by dialog through the closed front cover

Example : Calibration with buffers

## COMMISSIONING level

Functions required to commission the instrument are hidden to discourage unauthorized tampering. The front cover is removed to reveal the commissioning menu and the hidden access key (marked \*).

Use : For normal commissioning

How : Removal of the front cover reveals the access key and second menu

Example : Selecting a measuring range

## SERVICE level

Specialized functions can be adjusted via the SERVICE menu. In this case access is by using "service codes".

Use : Only for specialist functions

How : Through special coded entries

Example : Process temperature compensation

With this 3-level user-friendly approach, the instrument can be operated by anyone. Commissioning is straight-forward and needs no calibration equipment compared to analog instruments. Specialist functions available via access codes are invisible during normal operation. All three levels can be separately protected against unauthorized access by a password system using a three digit code.

## SENSOR CHECKING

### 1. On-line checks

Real-time sensor checking in the 2-wire transmitter is one of the most important features of the EXA PH202 transmitter. By special circuitry on the input board an alternating voltage is applied to the liquid earth pin and the sensors. The impedance of the measuring electrode (pH-glass or ORP-metal electrode) and reference electrode are independently measured. The measured values are compared to limiting values.

### 2. Faults

The pH-sensor is checked for low impedance to detect breakage of the bulb and for high impedance to detect an open circuit.

The Redox sensor is checked for high impedance to detect an open circuit.

The reference electrode is also checked for high impedance to detect fouling of the diaphragm, poisoning of the reference liquid or non immersion of the sensors.

These faults can be transmitted to the control room or remote panel by a discrete current output of 21 mA or 3.6 mA when HART or distributor comm. is non-used, 3.9 mA when HART or distributor comm. is used over the 2-wire connection. The fault is also flagged on the display by a special marker field and an error code in the message display.

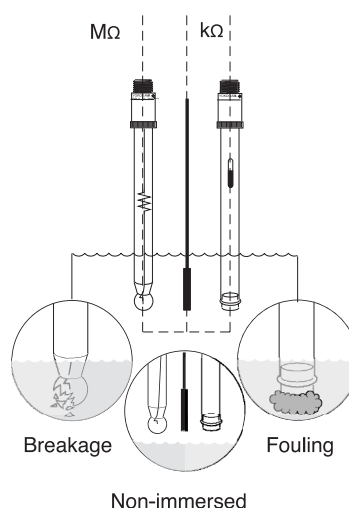

### 3. Off-line checks

During calibration of a pH measuring system, the response of the sensors is measured and checked. Sensitivity and drift are calculated and checked. During calibration of an ORP measuring system, the drift of the sensors is calculated and checked. If any of these are outside the limits, an error is signaled.

The comprehensive combination of on-line and off-line checking monitors all key aspects of the measurement to give an early warning, if the reading is faulty.

## GENERAL SPECIFICATIONS

### 1. Transmitter

Input specifications : Dual high impedance inputs (greater than  $10^{12} \Omega$ ) with provision for liquid earth connection. Suitable for inputs from glass or enamel pH & reference sensors and ORP metal electrodes.

Input ranges :

- pH : -2 to 16 pH
  - ORP : -1500 to 1500 mV
  - rH : 0 to 55 rH
  - Temperature : -30 to 140°C (-20 to 300°F)
  - 8.55k $\Omega$  NTC sensor : -10 to 120 °C ( 10 to 250°F)
  - for 10k $\Omega$  PTC sensor : -20 to 140 °C ( 0 to 300°F)
- (Measuring range may also be limited by the specification of the used sensor.)

Output ranges :

- pH : min. 1 pH max. 20 pH
- ORP : min. span 100 mV max. span 3000 mV
- rH : min. 2 rH max. 55 rH
- Temperature : min. 25 °C max. 200 °C (for 8.55k $\Omega$  NTC sensor max. 120 °C )

Output signal :

4-20 mA DC loop powered, isolated from input.

With the possibility of 21 mA "FAIL" signal (burn up) and 3.6 mA (burn down when HART or distributor comm. is non-used), 3.9 mA (burn down when HART or distributor comm. is used).

Temperature compensation:

- Range : -30 °C to 140 °C (-20 to 300 °F)  
(for 8.55kΩ sensor -10 °C to 120 °C)

Sensor types: Pt100, Pt1000, 3kΩ PTC, 5.1kΩ PTC, 8.55kΩ NTC, 350Ω PTC, 6.8kΩ PTC, 10kΩ PTC

Automatic or manual compensation to Nernst equation.  
Process compensation by configurable coefficient.  
Adjustable ITP (Iso-thermal point of intersection).

Calibration :

Semi-automatic, using tables in transmitter for pH 4, 7 & 9 buffer solutions, or using user-defined tables, with automatic check of measurement stability.

Manual, using standard sample, by correcting reading to value of standard.

Calibration by slope and asymmetry potential setting. (IEC746-2)

Logbook :

Software record of important events and diagnostic data. Available through HART link, with diagnostic information available in the display.

Serial communication:

Bi-directional digital communication superimposed on the 4-20 mA signal.

Display : Custom liquid crystal display, with a main display of 3 1/2 digits 12.5 mm high.

Message display of 6 alphanumeric characters, 7 mm high.

Warning flags and units (pH and mV).

Power supply : Nominal 24 volt DC loop powered system.

PH202G: 17 to 40 V, see Fig. 1.

Maximum load resistance:

For the PH202G, see Fig. 1.

200Ω or less with the PH201G

50Ω or less with the SDBT

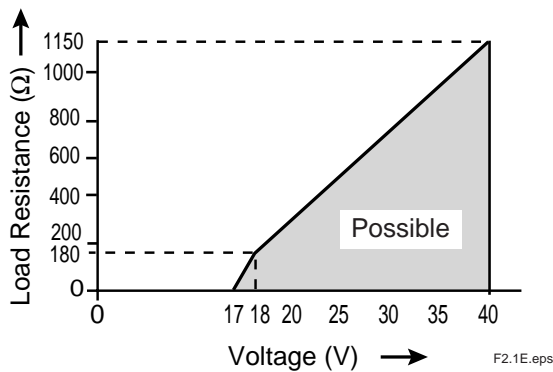

Fig.1 Supply voltage/ load diagram for the PH202G

Performance : (The specifications are expressed with simulated inputs.)

pH- Linearity : ± 0.01 pH

- Repeatability : ± 0.01 pH
- Accuracy : ± 0.01 pH

ORP- Linearity : ± 1 mV

- Repeatability : ± 1 mV
- Accuracy : ± 1 mV

Temperature with Pt1000, 3kΩ PTC, 5.1kΩ PTC, 8.55kΩ NTC, 350Ω PTC, 6.8kΩ PTC, 10kΩ PTC

- Linearity : ± 0.3 °C
- Repeatability : ± 0.1 °C
- Accuracy : ± 0.3 °C

Temperature with Pt100

- Linearity : ± 0.4 °C
- Repeatability : ± 0.1 °C
- Accuracy : ± 0.4 °C

Note: The following tolerance is added to above performance.

mA output tolerance: ± 0.02 mA of "4 - 20 mA"

Ambient operating temperature: -10 to + 55 °C

Storage temperature: -30 to +70 °C

Humidity : 10 to 90% RH (Non-condensing)

Housing :

Case: Cast aluminum case with chemically resistant coating

Cover: Polycarbonate window.

Case color: Off-white (Equivalent to Munsell 2.5Y8.4/1.2)

Cover color: Deep sea Moss green (Equivalent to Munsell 0.6GY3.1/2.0)

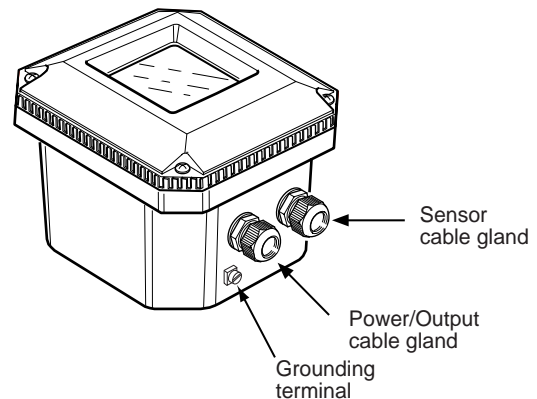

Cable and terminals :

The PH202 is equipped with terminals suitable for the connection of finished cables in the size: 0.13 to 2.5 mm (26 to 14 AWG)

Cable entry: 2 cable glands 1/2NPT. The cable glands will form a tight seal on cables with an outside diameter in the range of 6 to 12 mm (0.24 to 0.47 inches).

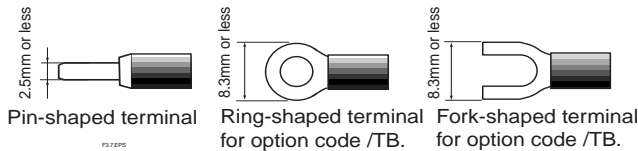

Requirement of connecting with external instruments

	Terminal for pin cable terminal	Screw terminal (option /TB)
Crimp contact for cable	Pin-shaped crimp contact with sleeve insulator	Ring-shaped or fork-shaped crimp contact
Usable contact	max. 2.5 mm	Crimp contact shown as the figures see upper this table, for M3 screw
Torque for fixing	0.5 N·m or less	1.35 N·m (recommended)
Example of crimp contact*	Weidmuller Co., Ltd. make: H0.34/10, H0.5/12, H1/12, H1.5/12S	JST, Mfg. Co., Ltd. make: VD1.25-3 (Ring shape), VD1.25-S3A (Fork shape)

\*Note: Other crimp contact may be required, depending on core-cable diameter.

T3.2E.eps

**Construction :**

Weather resistant to IP65, NEMA 4X and Type 3S standards

**Mounting :**

Pipe, wall or panel mounting, using optional hardware

Weight : Approx. 1.6 kg

**Data protection :**

EEPROM for configuration and logbook, and lithium cell for clock.

**Automatic safeguard :**

Return to measuring mode when no safe guard keystroke is made for 10 min.

**Operation protection :**

3-digit programmable password.

**Sensor impedance checking :**

Independent impedance check on measuring and reference sensor elements, with temperature compensation.

Display of sensor impedance on message line of display.

FAIL flag in event of "out of limits" impedance, and the possibility of 21 mA or 3.6 mA when HART comm. is non-used (3.9 mA when HART comm. is used) error signal.

**Signal processing (pH/ORP):**

The PH202 can measure pH or ORP. Using the FU20 allows simultaneous measurement and display of pH and ORP. It also allows display and out put of pH.

**EMC Conformity standards (PH202G) CE , N200**

EN 61326-1 Class A, Table 2 (For use in industrial locations)

EN 61326-2-3

EN 61326-2-5 (Profibus communication may be influenced by strong electromagnetic field.)

Korea Electromagnetic Conformity Standard

**HART® communications**

**Input** : Two-wire system, 4-20 mA DC  
**Power supply** : PH202G : up to 40 volts

Note: The transmitter contains a switched power supply, drawing its energy from the 0-4 mA section of the signal. Consequently the 17 volt limit is applied at 4 mA. The characteristic of the unit is such that above about 7 mA on the output, the terminal voltage can drop to 14.5 volts without problem.

**Transmission Signal** : Isolated output of 4 to 20 mA DC.  
 : Maximum load 425Ω at 24 VDC  
 Burn to signal failure acc. NAMUR Recommendation NE43 (18.01.1994)

**Operating range Communication** : 3.9 to 21mA  
 : HART®, 1200 Baud, FSK modulated on 4 to 20 mA signal

**Configuration Software** : Local with 6 keys  
 : Firmware based on Yokogawa stack.

**Hardware** : Yokogawa HART Modem F9197UB

**Other Control systems** : Yokogawa PRM, Rosemount AMS, Siemens PDM

**Hand Terminal Output span** : Rosemount HHT 275/375

**- pH** : min 1 pH, max 20 pH.  
 (max 90% zero suppression)  
 : The instrument is user programmable for linear or non-linear pH ranges.

**Cable specification:** 0.5 mm diameter or 24 AWG over maximum length of 1500 m

**DD specification** : The PH202 Device Description is available enabling communications with the Handheld communicator and compatible devices.

**PROFIBUS-PA communications**

**Input signal:** Digital  
**Supply voltage:** 9 to 32 V DC  
**Operating current:** 26.0 mA  
**Operating values:** According to IEC 1158-2  
**Bus connection:** Fieldbus interface based on IEC 1158-2 according to FISCO-Model  
**Power supply:** Power supply is achieved dependant on the application by means of segment coupler  
**Data transfer:** According to PROFIBUS- PA profile class B based on EN 50170 and DIN 19245 part 4  
**GSD file:** The actual file can be downloaded from [www.profibus.com](http://www.profibus.com)  
**Configuration:** Local with 6 keys  
**Software:** Firmware based on Siemens DPC31 stack.  
**Hardware:** PC- or PCMCIA-interfaces from Siemens  
**Other control:** Siemens PDM systems  
**Electrical connection:** Terminals acc. to IEC 1158-2  
**Fieldbus-cable-types:** Twisted and shielded two wire cable according to recommendation based on IEC 1158-2  
**Cable diameter:** 6 to 12 mm (0.24 to 0.47 inch)

**FOUNDATION Fieldbus H1 communications**

**Input signal:** Digital  
**Supply voltage:** 9 to 32 V DC  
**Operating current:** 26.0 mA (base current)  
**Operating values:** According to IEC 1158-2  
**Bus connection:** Fieldbus interface based on IEC 1158-2 according to FISCO-Model  
**Power supply:** Power supply is achieved dependant on the application by means of segment coupler  
**Data transfer:** FF Specification Rev. 1.4, Basic device  
**Function blocks:** 3xAI, Transducer, Resource  
**Files:** Actual file can be downloaded from our homepage

**Configuration:** Local with 6 keys,  
**Software:** National Instruments, NI-FBUS configurator  
**Hardware:** FBUS-interfaces from National Instruments  
(AT-FBUS and PCMCIA FBUS)  
**Other control systems:** Yokogawa PRM, DMT

2. Dedicated Distributor PH201G (Style B)

This distributor, designed exclusively for use with these pH transmitter, supplies drive power to the 2-wire transmitter while simultaneously receiving 4 to 20 mA DC current signal from the transmitter and converting it to 1 to 5 V DC voltage signal; it also simultaneously receives a digital signal superimposed on 4 to 20 mA DC signal, and provides contact outputs during hold, failure, and/or cleaning.

A current limiter function is built into this unit so it can continue to operate properly even with a short circuit on the transmitter side.

<Input/Output Signal Specifications>

Number of input points (Number of transmitter units connectable): 1 point  
Output signal: 1 to 5 V DC (2 points)  
Load resistance : 2 kΩ or less (1 to 5 V DC Output)  
Isolation system : Loop isolation type

<Mounting /Form>

Mounting method : Indoor rack mounting  
Connection method :  
External signal connection : M4 screw terminal connection  
Power supply / Ground connection :  
100V : JIS C8303 ground type 2 plug connection  
220V : CEE 7VII (European electrical device standard) plug connection  
Cable length : 300 mm

External dimensions : 180H x 48W x 300D mm  
Weight : Approx. 1.7 kg (Including rack and case)

<Standard Specifications>

Accuracy : ±0.2 % of span  
Transmitter supply voltage : 26.5 ± 1.5 V DC  
Maximum current and power consumption  
24 V DC : Approx. 4.8 W  
100 V AC : Approx. 7 VA  
220 V AC : Approx. 11 VA  
Insulation resistance  
Between I/O terminals and ground pin : 100 MΩ / 500 V DC  
Between power supply pins and ground pin : 100 MΩ / 500 V DC

<Operating Specifications>

Ambient temperature : 0 to 50°C  
Ambient humidity : 5 to 90 % RH (Non-condensing)  
Power supply : Dual use AC/DC  
100 V : DC power 20 to 130 V, no polarity  
AC power 80 to 138 V, 47 to 63 Hz  
220 V : DC power 120 to 340 V, no polarity  
AC power 138 to 264 V, 47 to 63 Hz

<Contact Output>

Contact rating : 250 V AC, maximum 100 VA  
220 V DC, maximum 50 VA  
Hold contact output : N.C. 1 contact, Normally energized  
Contact closes when power is off or during maintenance.  
Failure contact output : N.C. 1 contact, Normally energized  
Contact closes when power is off or during failure.  
Cleaning contact output : 1 contact, Close during cleaning only  
Used as drive contact for solenoid valve for cleaning.

System Configuration Example

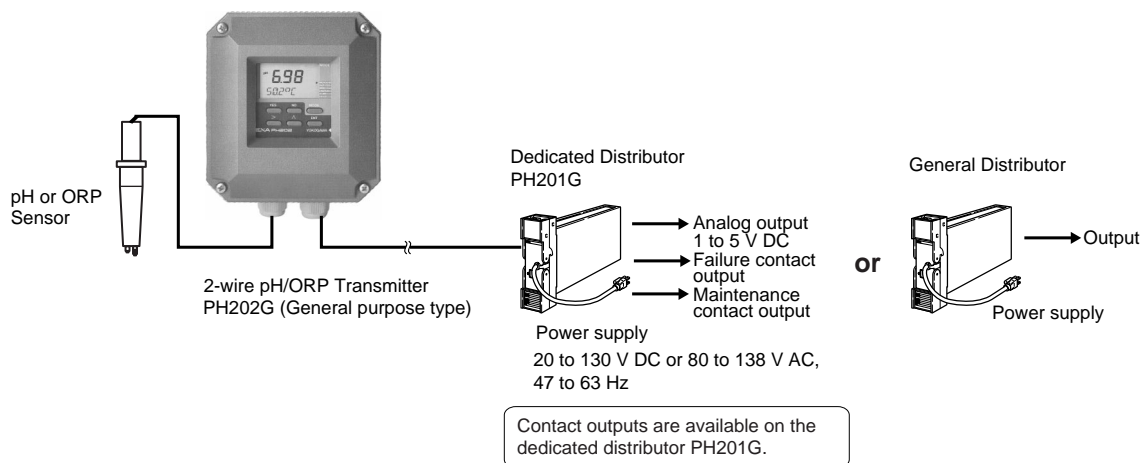

**MODEL AND SUFFIX CODES**

**1. 2-Wire pH/ORP Transmitter (Non-explosionproof type)**

[Style : S3]

Model	Suffix Code	Option Code	Description
<b>PH202G</b>	.....	.....	2-Wire pH/ORP Transmitter (*1)
Type	-E -C -U -P -F	..... ..... ..... ..... .....	mA with HART (For other regions) mA with HART (Canada type) mA with HART (North America type) Profibus FF
Language	-J -E	..... .....	Japanese English
Option	Mounting Hardware  Hood  Tag Plate Conduit Adapter	/U /PM /H /H2 /SCT /AFTG /ANSI /TB /X1	Pipe, wall mounting bracket (Stainless steel) Panel mounting bracket (Stainless steel) Hood for sun protection (Carbon steel) Hood for sun protection (Stainless steel) Stainless steel tag plate G 1/2 1/2 NPT Screw terminal (*2) Epoxy baked finish (*3)

(\*1) The PH202G can be also used as ORP transmitter. (Setting can be made in the field. )

T8-1.eps

(\*2) It can be specified when the suffix code "-E" or "-C" or "-U" is selected.

(\*3) The housing is coated with epoxy resin.

**2. Distributor (Dedicated EXA Series)**

Model	Suffix Code	Option Code	Description
<b>PH201G</b>	.....	.....	Distributor
Power Supply	-A1 -A2	..... .....	100 V AC 220 V AC
—	*B	.....	Style B
Option		/TB	Terminal for power connection

T8-2.eps

**DIMENSIONS**

**pH/ORP Transmitter**

**Panel Mounting (Option code : /PM)**

Unit : mm

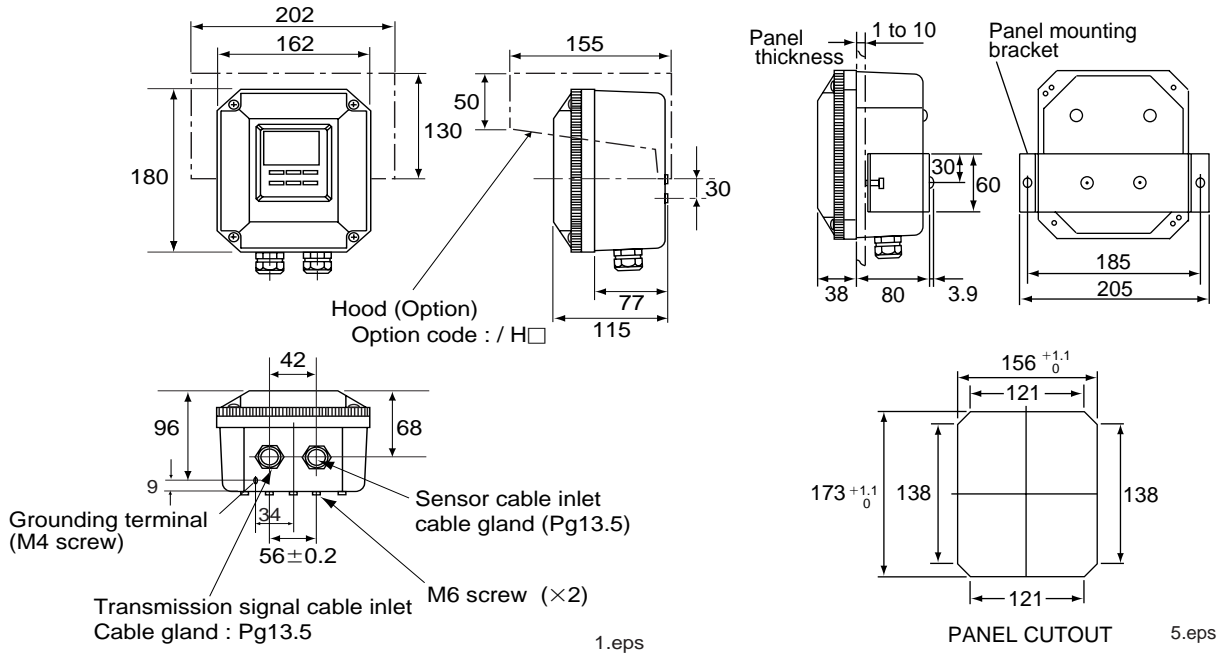

**Conduit Adapter (Option)**

**Panel Mounting when using two (2) self-taping screws**

Adapter for Conduit Work (optional)  
(option code : / AFTG, / ANSI)

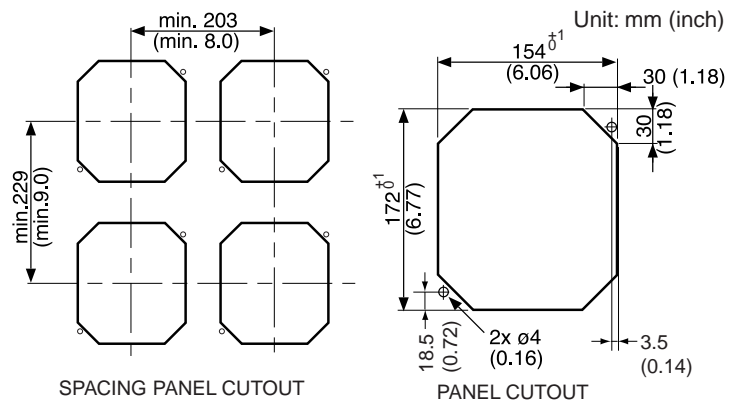
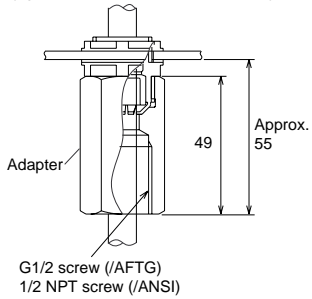

**Pipe/Wall Mounting (Option code : /U)**

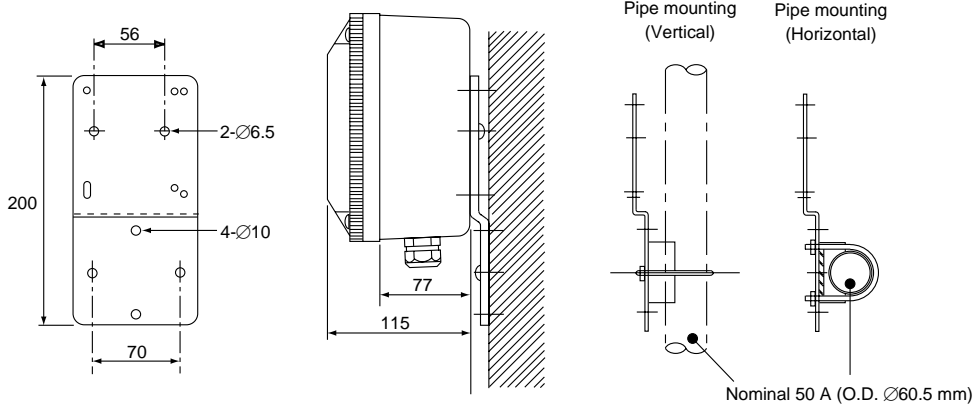

4.eps



**Wiring Example for Sensors**

**General pH electrode**

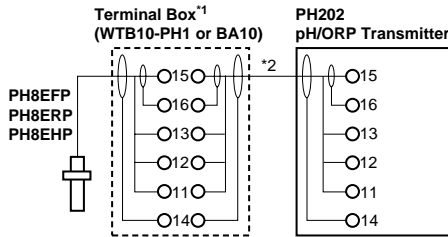

**Special pH electrode**

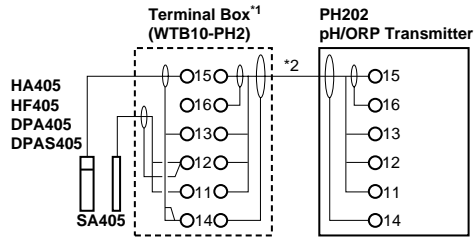

Note : Both "SE(14)" terminals of the pH detector is connected to the "SE(14)" terminal of the PH202. Nothing is connected to the "S(16)" terminal of the PH202.

**Separate electrodes pH/Ref electrode**

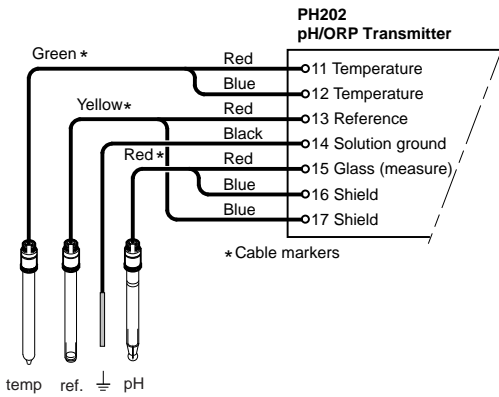

**Combined pH/ref electrode**

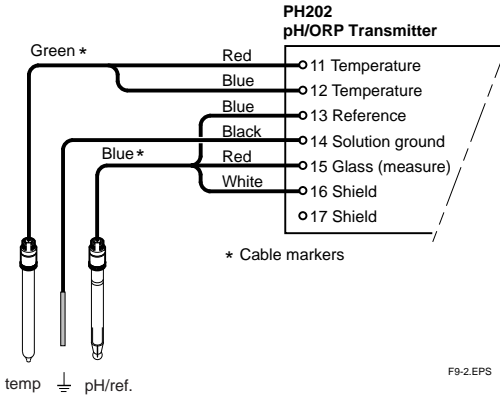

\*1 Terminal box is used only where pH/ORP transmitter is installed remotely from electrodes (normally not needed).  
\*2 This cable is specified in the option code for the terminal box (WTB10), or extension cable (WF10).

**General ORP electrode**

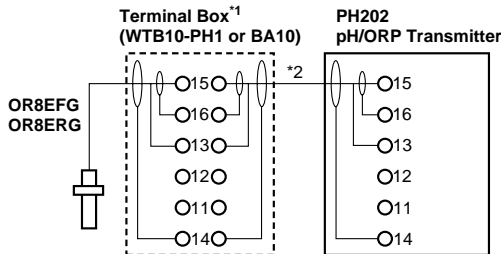

**Special ORP electrode**

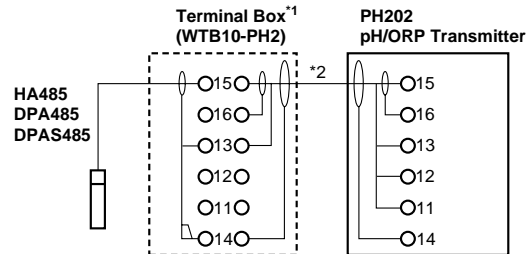

**Separate electrodes ORP/Ref electrode**

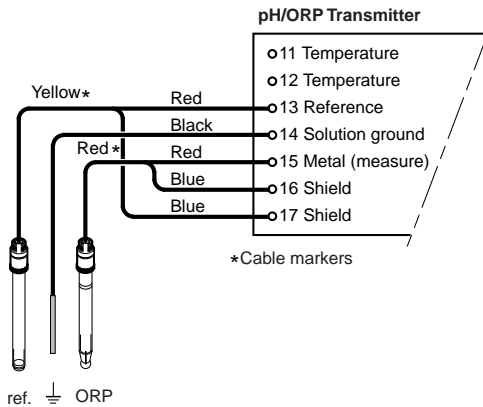

**Combined ORP/Ref electrode**

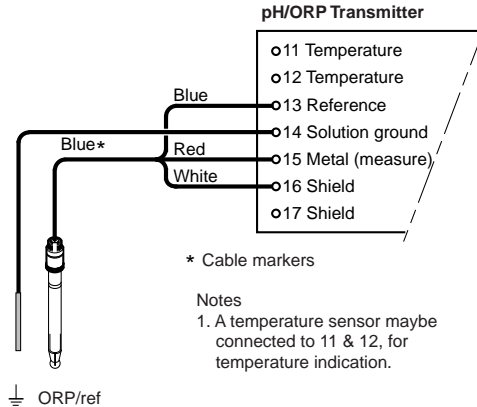

Notes  
1. A temperature sensor maybe connected to 11 & 12, for temperature indication.

\*1 Terminal box is used only where pH/ORP transmitter is installed remotely from electrodes (normally not needed).  
\*2 This cable is specified in the option code for the terminal box (WTB10), or extension cable (WF10).

F9-2-1.EPS

**Wiring of the PH20/FU20**

**pH (& ORP) WIRING DIAGRAM**

Conventional pH (&ORP) wiring  
 Connect the PH20 or FU20 to the EXA or EXAxt PH analyzer as shown. With this configuration, it is possible to measure ORP (or rH) at the same time.

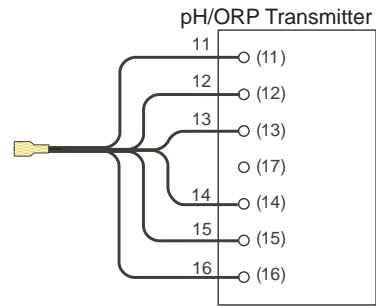

**ORP WIRING DIAGRAM with normal reference**

Wiring for ORP measurement with normal reference  
 Connect the PH20 or FU20 to the EXAPH analyzer as shown.

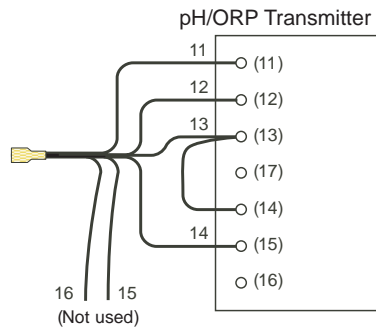

**ORP WIRING DIAGRAM with pH sensor as reference**

Wiring for ORP measurement with pH reference  
 Connect the PH20 or FU20 to the EXA Glass PH analyzer as shown.

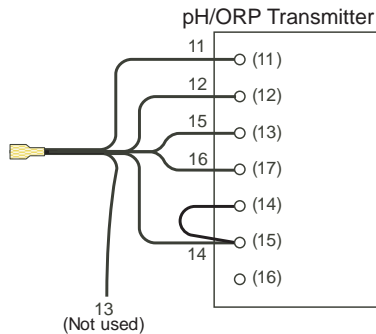

To connect the other sensor systems, follow the general pattern of the terminal connections as listed below:

- 11 & 12      Temperature compensation resistor input      (= T1 and T2)
- 13          Input no. 2 (normally the reference element) = RE
- 17          Screen (shield) for input no. 2
- 14          Liquid earth (solution ground) connection      = SE or LE
- 15          Input no. 1 (normally the measuring element) = GE
- 16          Screen (shield) for input no. 1                      = S or G

### Inquiry Specifications Sheet for 2-Wire pH/ORP (Redox) Transmitter System

Make inquiries by placing checkmarks (✓) in the pertinent boxes and filling in the blanks.

1. General

Company name; \_\_\_\_\_  
 Contact person ; \_\_\_\_\_ Section: \_\_\_\_\_ Department: \_\_\_\_\_  
 Plant name ; \_\_\_\_\_  
 Measurement location ; \_\_\_\_\_  
 Purpose of use ;  Indication,  Record,  Alarm,  Control  
 Power supply ; \_\_\_\_\_ V AC \_\_\_\_\_ Hz

2. Measurement Conditions

(1) Process temperature ; \_\_\_\_\_ to \_\_\_\_\_ Normally \_\_\_\_\_ [°C]  
 (2) Process pressure ; \_\_\_\_\_ Normally \_\_\_\_\_ [kPa]  
 (3) Flow rate ; \_\_\_\_\_ Normally \_\_\_\_\_ [l/min]  
 (4) Flow speed ; \_\_\_\_\_ Normally \_\_\_\_\_ [m/sec]  
 (5) Slurry or contaminants,  No,  Yes  
 (6) Name of process fluid ; \_\_\_\_\_  
 (7) Composition of process fluid ; \_\_\_\_\_  
 (8) Others ; \_\_\_\_\_

3. Installation Site

(1) Ambient temperature ; \_\_\_\_\_  
 (2) Installation location,  Outdoors,  Indoors \_\_\_\_\_  
 (3) Others ; \_\_\_\_\_

4. User Requirements

(1) Measuring range ;  pH 0 to 14  \_\_\_\_\_  
 (2) Transmission output ;  4 to 20 mA DC  HART®  PROFIBUS-PA  FOUNDATION Fieldbus H1  
 (3) System configuration selection ;  Sensor,  Holder,  pH/ORP transmitter,  Cleaning system,  
 Terminal box,  Accessories  
 (4) Electrode cable length;  3m  5m  7m  10m  15m  20m  \_\_\_\_\_ m  
 (5) Electrode operating pressure;  10 kPa or less,  Greater than 10 kPa  
 (6) Type of holder ;  Guide pipe,  Submersion,  Flow-through,  Suspension,  Angled floating ball,  
 Vertical floating ball  
 (7) Cleaning method ;  No cleaning,  Ultrasonic cleaning,  Jet cleaning,  Brush cleaning  
 (8) Sample temperature ;  -5 to 105°C  -5 to 100°C  -5 to 80°C  
 (9) Others ; \_\_\_\_\_