

# General Specifications

Model ISC450G  
Inductive Conductivity Converter



GS 12D06D05-01E

The new EXAxt 450 series has been designed to meet the highest market requirements of today's industry. This series of analyzers is unique as it will no longer be the uncertainty factor of your quality demands, but instead will bring you to a higher level. The EXAxt will help you and guide you as the unique Human Machine Interface (HMI) will not only present you reliable process data, but diagnostics, trends, logbooks and step by step calibration routines to become your friend in analytical measurement and help you gaining that higher level of quality.

The instrument is easy to set up, very intuitive and can be used without the need of an instruction manual. The HMI has a clear menu structure in the language of your preference (English, French, German, Spanish, Italian, Swedish Portuguese and Japanese.) The touch screen interface provides access to the display features. The main display gives three process values at the same time.

This makes it possible to provide Conductivity, Concentration and Temperature reading at the same time. Predefined compensation matrices with integrated concentration tables makes it possible to have concentration readings readily available.

The EXAxt is highly intelligent and continuously checks the software, hardware and sensor system for irregularities. Not only will these irregularities be signaled through the main display as well as a signal output according Namur NE43, the converter will provide adequate instructions how to solve the errors.

## System Configuration

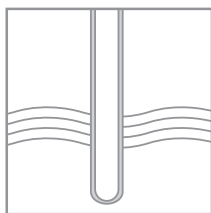

Sensors

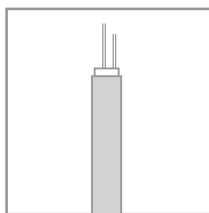

Cables

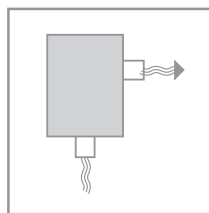

Fittings

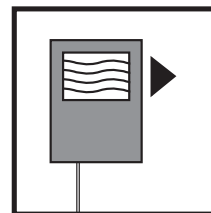

Transmitters

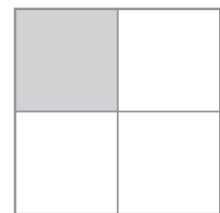

Accessories



## Features

- Unique intuitive HMI menu structure in 8 languages.
- Process data trending up to 2 weeks.
- Predefined OIML standard solutions.
- Predefined matrices for precise temperature compensation.
- Two mA-outputs and four SPDT relay contacts with display indicators.
- %weight on display.
- HART® Communications.
- FM Class I, Div. 2, Group ABCD, T6 for Ta -20 to 55°C

## General Specifications

### General Specifications of EXAxt ISC450

#### A. Input specifications

- : Compatible with the Yokogawa inductive conductivity ISC40 series with integrated temperature sensor: NTC30k or Pt1000.

#### B. Input ranges

- Conductivity : 0 to 1999 mS/cm at 25°C (77 °F)
- Minimum : 1 µS/cm (at process temperature)
- Maximum : 2 S/cm (at process temperature)
- Temperature : -20 to +140°C (0 to 280 °F).
- Cable length : max. 60 meters (200 feet)  
10 meters (35 feet) fixed sensor cable + 50 meters (165 feet) WF10 extension cable. Influence of cable can be adjusted by doing an AIR CAL with the cable connected to a dry cell.

**C.Accuracy**

- Conductivity :  $\leq 0.5\%$  of reading  $\pm 1.0 \mu\text{S/cm}$   
 Temperature :  $\leq 0.3^\circ\text{C}$  ( $0.6^\circ\text{F}$ )  
 Temp.compensation  
     :  $\leq 1\%$  for NaCl,  $\leq 3\%$  for matrix  
 Step response :  $\leq 4$  seconds for 90 %  
     (for a 2 decade step).

**Note on performance specifications**

The following tolerance is added to above performance.  
 mA output tolerance:  $\pm 0.02$  mA of "4-20 mA"

**D.Transmission signals**

- General : Two isolated outputs of 4-20 mA. DC with common negative. Maximum load  $600\Omega$ . Bi-directional HART® digital communication, superimposed on mA1 (4-20mA) signal.  
 Output function : Linear or 21-step table for Conductivity, Concentration or Temperature.  
 Control function : PID control.  
 Burn out function  
     : Burn up (21.0mA) or burn down (3.6mA) to signal failure. acc. NAMUR NE43.  
 Parameters : Adjustable damping  
               : Expire time  
 Hold : The mA-outputs are frozen to the last/fixed value during calibration/commissioning  
 Cond. range : min span  $10\mu\text{S/cm} \geq 10\%$  of high value (20mA)  
               : max span 1999 mS/cm

**E.Contact outputs**

- General : Four SPDT relay contacts with display indicators.  
 Switch capacity : Maximum values 100 VA, 250 VAC, 5 Amps. (\*)  
                   : Maximum values 50 Watts, 250 VDC, 5 Amps. (\*)  
 Status : High/Low process alarms, selected from conductivity, resistivity, concentration or temperature. Configurable delay time and hysteresis.  
           : PID duty cycle or pulsed frequency control.  
           : FAIL alarm  
 Control function : On / Off  
                   : Adjustable damping  
                   : Expire time  
 Hold : Contact can be used to signal the Hold situation.  
 Fail safe : Contact S4 is programmed as fail-safe contact.

(\*)Note: When contact output current is more than 4 Amps, ambient temperature should be less than  $40^\circ\text{C}$ .

**F.Contact input** : Remote range switching to 10 times the programmed range.

- Contact open : If impedance  $> 100\text{ k}\Omega$ : "Range1, 2"  
               ("Programmed range for mA1 and mA2 output" is "Range1, 2.")  
 Contact closed : If impedance  $< 10\Omega$ :  
                    $10 \times$  "Range1, 2"

**G.Temperature compensation**

- : Automatic or manual, for temperature ranges mentioned under B (inputs).  
 - Reference temp.  
     : programmable from  $0$  to  $100^\circ\text{C}$  or  $30 - 210^\circ\text{F}$  (default  $25^\circ\text{C}$ ).

**H.Calibration** : Semi-automatic calibration using pre-configured OIML\* (KCl) standard tables, with automatic stability check. Manual adjustment to grab sample.

\* Organisation Internationale de Metrologie Legale, international recommendation nr. 56 standard solutions reproducing the conductivities of electrolytes, 1981.

**I.Logbook** : Software record of important events and diagnostic data readily available in the display or through HART®.**J.Display** : Graphical Quarter VGA (320 x 240 pixels) LCD with LED backlight and touchscreen. Plain language messages in English, German, French, Spanish, Italian, Swedish, Portuguese and Japanese.**K.Shipping details**

- Package size : 290 x 300 x 290 mm (L x W x D)  
               (11.5 x 11.8 x 11.5 inch)  
 Package weight: Approx 2.5 kg (5.5 lbs)  
 Converter weight: Approx. 1.5 kg

**L.Housing** : Cast Aluminium housing with chemically resistant coating; Polycarbonate cover with Polycarbonate flexible window

: Protection IP66 / NEMA 4X / CSA Type 3S

Colour : Silver grey

ISC450G-A(D)-A:IP66 cable glands are supplied with the unit

ISC450G-A(D)-U:NEMA 4X close up plugs are mounted in the unused cable entry holes and can be replaced by conduit fittings as required  
 Pipe, Panel or Wall mounting using optional hardware.

Optional conduit adapter

G1/2, 1/2NPT or M20 female

**M.Power supply :**

ISC450G-A :Ratings; 100-240 V AC Acceptable range; 90 to 264 V AC  
 Ratings; 50/60 Hz Acceptable range; 50 Hz  $\pm 5\%$ , 60 Hz  $\pm 5\%$   
 Power Consumption; 15 VA

ISC450G-D :Ratings; 12-24 V DC Acceptable range; 10.8 to 26.4 V DC  
 Power Consumption; 10 W

**N.Safety and EMC conforming standards**

- Safety :EN 61010-1  
 CSA C22.2 No.61010-1  
 UL 61010-1  
 FM3611 Class I, Div.2, Group ABCD,T6 for Ta -20 to  $55^\circ\text{C}$

EMC :EN 61326-1 Class A, Table 2  
 (For use in industrial locations)  
 EN 61326-2-3  
 EN 61000-3-2 Class A  
 EN 61000-3-3  
 Korea Electromagnetic Conformity Standard

Installation altitude: 2000 m or less  
 Category based on IEC 61010: II (Note)  
 Pollution degree based on IEC 61010: 2 (Note)  
 Note: Installation category, called over-voltage category, specifies impulse withstand voltage. Category II is for electrical equipment. Pollution degree indicates the degree of existence of solid, liquid, gas or other inclusions which may reduce dielectric strength. Degree 2 is the normal indoor environment.

**O.Environment and operational conditions**

Ambient temperature : -20 to +55°C (-5 - 130°F)  
 Storage temperature : -30 to +70°C (-20 - 160°F)  
 Humidity : 10 to 90% RH at 40°C (100°F) (non-condensing)  
 Data protection : EEPROM for configuration data and logbook. Lithium cell for clock.  
 Watchdog timer : Checks microprocessor.  
 Power down : Reset to measurement.  
 Automatic safeguard : Auto return to measuring mode when touchscreen is not touched for 10 min.

**Model and Suffix Codes [Style: S2]**

Model	Suffix code	Option Code	Description
ISC450G	-----	-----	Inductive Conductivity Converter
Power	- A	-----	AC version (100...240 VAC)
	- D	-----	DC version (12...24 VDC)
Type	- A	-----	General purpose version
	- U	-----	FM version
Mounting Hardware	/UM	-----	Universal mounting kit (panel, pipe, wall)
	/U	-----	Pipe and wall mounting hardware (*2)
Hood	/PM	-----	Panel mounting hardware (*2)
	/H5	-----	Awning hood (stainless steel) (*2)
Conduit adapter	/AFTG	-----	G1/2 (*2)
	/ANSI	-----	1/2NPT (*2)
Tag Plate	/AM20	-----	M20 (*2)
	/SCT	-----	Stainless steel tag plate (*1)

\*1 If the tag number is predefined with the purchase, Yokogawa will inscript the tag plate with the specified tag number, and program the tag number in the converter.  
 \*2 Option codes /U, /PM, /H5, /AFTG, /ANSI and /AM20 are not specified for FM version (-U).

**Display and Operating Interface**

The display is a backlight graphical display with QVGA resolution. Operation is done by a touchscreen. Graphical keys on the right and other area's of the touchscreen respond to contact as virtual push buttons.

**Main screen**



**The main screen displays:**

- The primary variable in large font (user selectable)
- Other process variable(s) in small font
- Unit symbols
- Tag number (user programmable)
- Process description (user programmable)
- Status of contact output(s)
- Status indicator during HOLD situation
- Main function keys

**Trend screen**

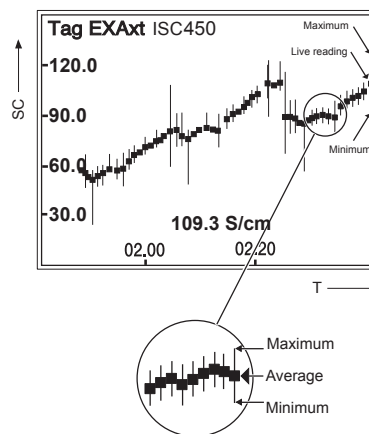

**The trend screen displays:**

- Time scale. User selectable (between 15 minutes and 2 weeks)
- PV scale. User selectable
- Tag number
- Actual PV
- Average, maximum and minimum PV in this interval (time scale / 51)

**Zoom screen**

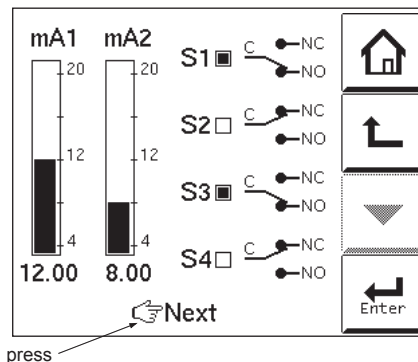

The zoom screen displays an easy graphic representation of the output functions. When "Next" is pressed it will give access to the logbook data.



### Status screen

The status screen gives access to diagnostic information with regards to analyzer or sensors.



No malfunction detected.



Soft alarm detected. Maintenance is recommended for best accuracy.



Hard alarm is detected indicating malfunction that is critical for good analysis. When this key is pressed details are displayed with regards to detected malfunction and troubleshooting guidelines are displayed to resolve the malfunction.

<p>Most applicable error:</p> <p>Conductivity too high</p> <p>Explanation</p> <p>Advanced troubleshooting</p>	   	<p>Conductivity exceeds high limit setting.</p> <p>Remedy</p> <p>Check connections and cable. Replace sensor. Adjust limits in: Commissioning » Error configuration</p>	   
---	--------------	---	--------------



### Maintenance screen

The maintenance screen gives access to calibration, commissioning and setup of the instrument. These levels can be protected by passwords.

#### Example

<p>EXAxt ISC450</p> <p>Execute:</p> <p>Calibration</p> <p>HOLD</p> <p>Setup:</p> <p>Commissioning</p> <p>Change language</p> <p>Service</p>	   	<p>Read logbook:</p> <p>Sensor data</p> <p>Output data</p> <p>Calibration</p> <p>mA1</p>	   
---	--------------	--	--------------

## Output and Alarm Functions

### Output signal

The standard ISC450 features two 4-20 mA current outputs available for registration, and indication or control functions.

The user selectable application can represent:

- the measured conductivity value
- the concentration in wt%
- the measured temperature value

In addition the following output functions are available:

- a "HOLD" function that maintains process value or a fixed value until return to normal operation
- a "BURN" function that gives a high or low output at fail status
- a programmable output function that allows the user to linearise the output(s) when used as a concentration analyzer.

Two isolated mA outputs are provided, and can be set for linear or scaled output signals. Alternatively PID analogue control is available on either or both mA outputs. The converter or control parameter may be SC, concentration or temperature. Control settings are fully

configurable.

Code Output	mA 4-20	Conc.	Example %H <sub>2</sub> SO <sub>4</sub>	Cond.	Example mS/cm
0	4.0		0.00		0
5	4.8		1.25		60
10	5.6		2.50		113
15	6.4		3.75		180
20	7.2		5.00		211
25	8.0		6.25		290
30	8.8		7.50		335
35	9.6		8.75		383
40	10.4		10.00		424
45	11.2		11.25		466
50	12.0		12.50		515
55	12.8		13.75		555
60	13.6		15.00		590
65	14.4		16.25		625
70	15.2		17.50		655
75	16.0		18.75		685
80	16.8		20.00		718
85	17.6		21.25		735
90	18.4		22.50		755
95	19.2		23.75		775
100	20.0		25.00		791

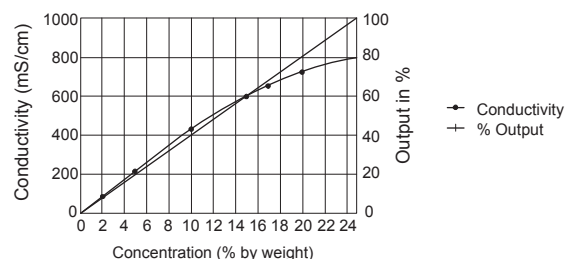

### Linearisation of output

#### Example: 0-25% Sulfuric acid

Four SPDT relays are included as standard, and can be configured by the user as conventional process alarms, or in one of 2 control modes:

#### 1) PID duty cycle control

In this type of control, the on/off ratio is controlled to vary the dose rate through a solenoid valve. This is a very economic way of achieving PID control.

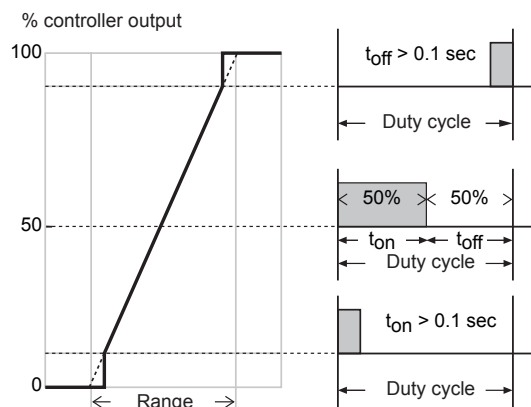

## 2) PID pulse frequency control

The pulsing frequency is regulated to control electrical valve opening or pump stroke.

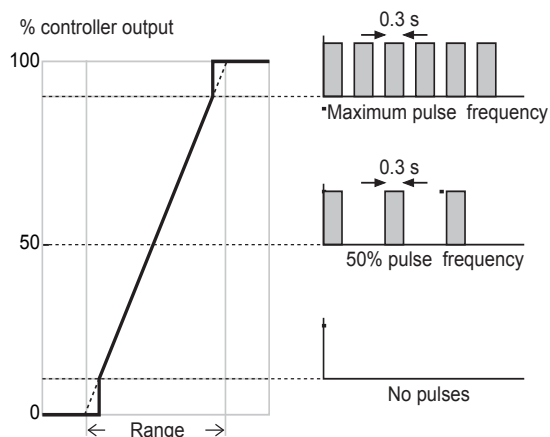

In each case the setpoint, PB, I and D terms are all easily adjustable in the ISC450.

### Configuration of contacts

Contact	Normal operation	Alarm situation	Powerdown
S1, S2, S3	NO C — NC	C — NO NC	NO C — NC
S4	NO C — NC	C — NO NC	NO C — NC

### Measurement Principle

Unlike 2- or 4-electrode conductivity systems, the EXA ISC450G analyses the conductivity without any contact between electrodes and process fluid. The measurement is based on inductive coupling of 2 ring transformers (toroids) by the liquid.

The EXA ISC450 supplies a reference voltage ( $V_1$ ) at a high frequency to the "drive coil". The core of this coil is of a high permeability magnetic material, and a strong magnetic field is generated in the toroid.

The liquid passes through the hole in the toroid and can be considered as a "one turn" secondary winding.

The magnetic field induces a voltage ( $V_2$ ) in this liquid winding. The induced current thus made to flow is proportional to this voltage and the conductance of the liquid "one turn winding" is according to Ohm's law.

The conductance ( $G=1/R$ ) is proportional to the specific conductivity and a constant factor that is determined by the geometry of the sensor (length divided by surface area of the hole in the toroid) and the installation of the sensor.

There are 2 toroids mounted in the doughnut shaped sensor. The liquid also flows through the second toroid and therefore the liquid turn can be considered as a primary winding of the second ring transformer. The current in the liquid will create a magnetic field in the second toroid. The induced voltage ( $V_3$ ) being the result of this magnetic field can be measured as an output. The output voltage of this "receive coil" is therefore

proportional to the specific conductivity of the process liquid.

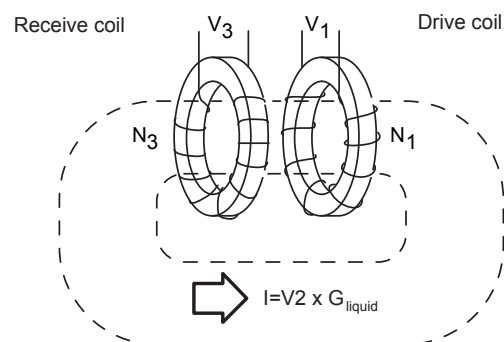

### Inductive conductivity measurement principle

### Functional Description

The EXA ISC450G is real time micro-controller operated conductivity-analyzing system. It uses a dedicated micro-controller to control all functions necessary in such a system. The input and output functions are concentrated in the analog section of the instrument. Even these functions are operated through special interfaces designed to minimize interference with the digital functions. All functions are executed separately.

The power of the microprocessor is used for:

- Diagnostic functions to increase the dependability of the instrument.
- A self-tuning preamplifier to increase the range ability to cover almost all conductivity applications.
- Input/output flexibility to offer the user solutions to compatibility problems and to non-linearity characteristics of some electrolytes.
- Auto zeroing to ensure long term stability
- Sophisticated temperature compensation to achieve temperature independent readings for even the most difficult processes like Sulfuric Acid and Sodium Hydroxide.

### Installation and Wiring

#### Installation site

The converter is a rain-tight type, and can be installed inside or outside. It should, however, be installed as close as possible to the sensors to avoid long cable lengths between sensors and converter. Select an installation site where:

- Mechanical vibrations and shocks are negligible.
- No relay/power switches are in the direct environment.
- The converter is not mounted in direct sunlight and severe weather conditions.
- Maintenance activities are possible (no corrosive atmospheres).

The ambient temperature and humidity of the installation environment must be within the limits of the instrument specifications.

#### Mounting methods

The EXA ISC450G converter has universal mounting possibilities:

- Panel mounting using optional brackets.

- Surface mounting on a plate (by bolts from the back).
- Wall mounting on a bracket (e.g. thick brick wall).
- Pipe mounting using a bracket on a horizontal or vertical pipe (nominal diameter JIS 50A).

### Installation of the sensor

The ISC40 is a doughnut shaped sensor. Ideally, the process flows through the hole of the doughnut with the temperature compensator up-stream. For minimal obstruction of the flow and for accurate measurement without the need for calibration of the installation factor, the process should flow freely around the doughnut. This is effected by allowing a minimum distance of 25 mm (1 in) between doughnut and process piping (d).

The sensor is provided with a gasket and retaining nut. This allows "bulkhead mounting" in tank wall or standard flange through a hole of 27 mm (1.1 in) diameter (A). The insertion depth is 125 mm. Two flats are provided with wrench size 20 mm (0.8 in) to allow easy mounting and alignment of the sensor. The model identification on one flat aligns with the "up-stream" position of the sensor.

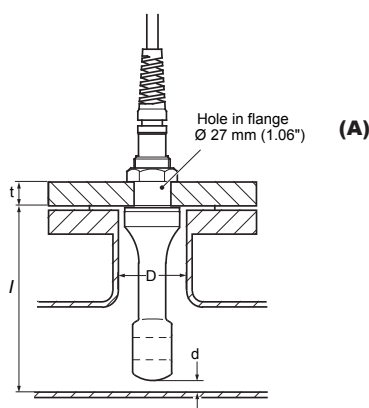

d = distance min 25 mm (1")  
D = access port size min 48 mm (1.89")

### Dimension and installation instruction bulk-head mounting

For PEEK and PFA

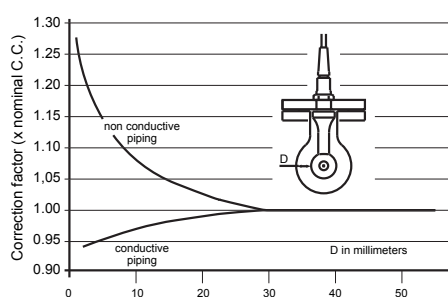

Installation factor as a function of free distance around doughnut

It is recommended to use Yokogawa supplied mounting options, flow fittings, immersion fittings or subassemblies. These holders feature double O-ring seals to prevent that chemical attack of the seal will damage the sensor by ingress of process liquid in the sensor.

- For on-line mounting, adapters are available for standard 2" process connection (Gas thread, NPT,

ANSI-flange, DIN-flange).

- For by-pass measurement, flow fittings are available in Polypropylene, Polyvinylidene Fluoride and Stainless Steel.
- For measurements in open ducts or vessels, an immersion fitting in CPVC is available.

For easy wiring the sensor should be located within 2 or 10m (16 or 32ft) from the converter using the integral sensor cabling.

Up to 50 meters of WF10 extension cable may be used with a BA10 junction box. The installation factor of the ISC40 is the ratio of the measured conductivity at the sensor and the specific conductivity of the solution.

The unit is  $\text{cm}^{-1}$  just as the cell constant of a contact electrode system. This factor is  $1.88 \text{ cm}^{-1}$  for the ISC40 if the sensor is installed with a minimum of 25 mm (1 in) of process fluid surrounding the doughnut.

- Installed in an ISC40FF-S stainless steel flow cell, the factor is  $1.7 \text{ cm}^{-1}$ .
- Installed in an ISC40FF-P polypropylene flow cell, the factor is  $1.88 \text{ cm}^{-1}$ .
- The factor may be estimated from diagram (PEEK and PFA) for actual installations not using the standard flow assemblies.
- The I.F. or cell constant of ISC40 sensors made of PFA is  $3.0 \text{ cm}^{-1}$ .

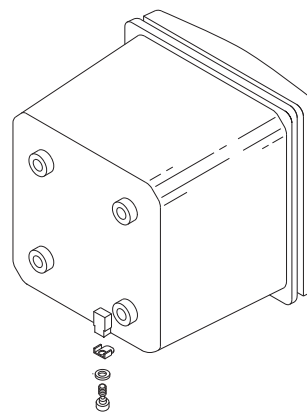

Grounding

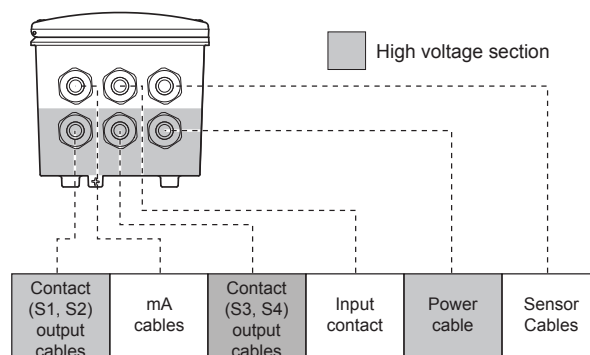

Glands to be used for cabling

**Dimensions and Mounting**

Unit: mm (inch)

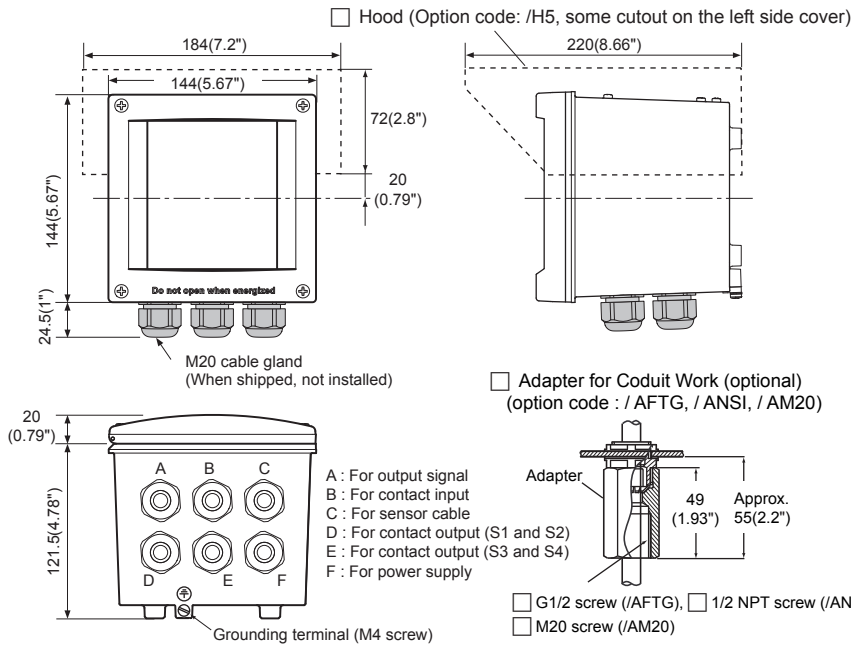

**Housing dimensions, layout of glands and conduit adapter**

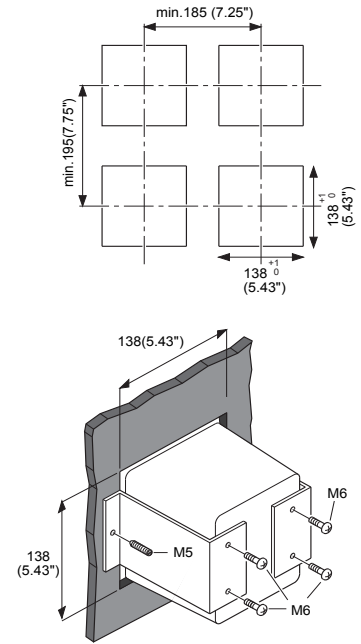

**Option /PM: panel mounting diagram**

**(Note)**When option code "/UM" is specified, universal pipe/wall/panel mounting kit are supplied---same as option code "/U" and "/PM" both specified.

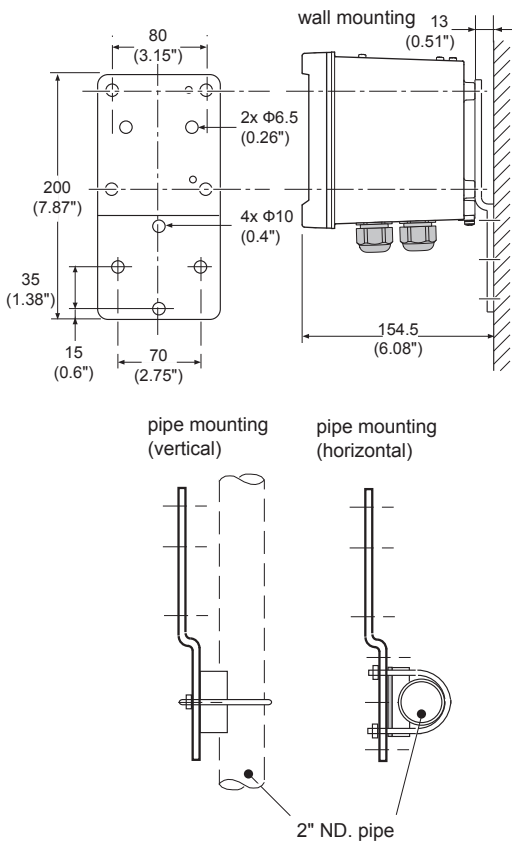

**Option /U: wall and pipe mounting diagram**

**ISC40 Sensor**

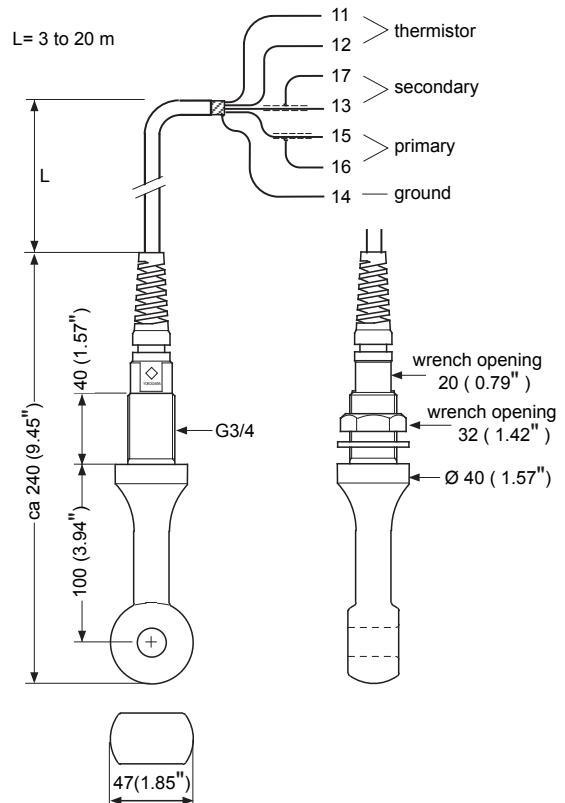

## Wiring Diagram

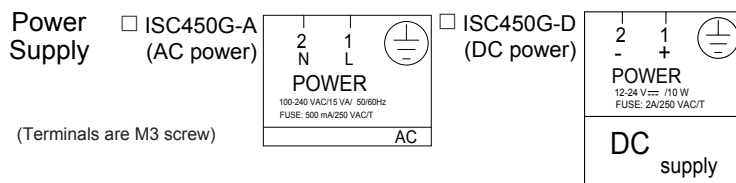
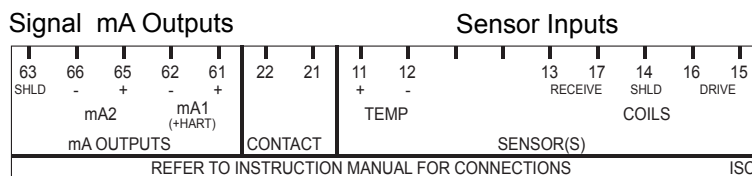
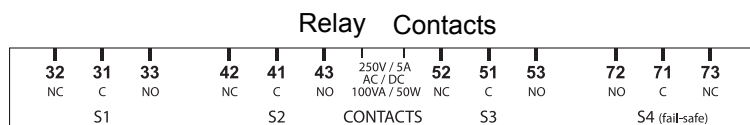

## Wiring

When wiring the converter, the following guidelines should be used for cable selection, in order to ensure the correct sealing of the cable glands and the correct operation of the terminals.

Overall cable diameter : 6-12 mm  
(0.24"- 0.47")  
Conductor cross section : 0.13 mm<sup>2</sup>  
- 4.0 mm<sup>2</sup>  
(26-12 AWG)

## Inquiry Specifications Sheet for Inductive Conductivity Converter System

Make inquiries by placing checkmarks (✓) in the pertinent boxes and filling in the blanks.

### 1. General information

Name of your company: \_\_\_\_\_

Name of inquirer: \_\_\_\_\_ Dept. or sect.: \_\_\_\_\_ (telephone: \_\_\_\_\_ )

Name of plant: \_\_\_\_\_

Measuring point: \_\_\_\_\_

Purpose of use:  Indication  Record  Alarm  Control

Power supply: \_\_\_\_\_ V  AC  DC

### 2. Measuring conditions

(1) Liquid temperature: \_\_\_\_\_ to \_\_\_\_\_, normally \_\_\_\_\_ [°C]

(2) Liquid pressure: \_\_\_\_\_ to \_\_\_\_\_, normally \_\_\_\_\_ [kPa]

(3) Flow rate: \_\_\_\_\_ to \_\_\_\_\_, normally \_\_\_\_\_ [l/min.]

(4) Flow speed: \_\_\_\_\_ to \_\_\_\_\_, normally \_\_\_\_\_ [m/s]

(5) Slurry or contaminants:  Absent  Present

(6) Name of liquid: \_\_\_\_\_

(7) Composition of liquid: \_\_\_\_\_

(8) Other remarks: \_\_\_\_\_

### 3. Installation environment

(1) Ambient temperature: \_\_\_\_\_

(2) Location:  Outdoors  Indoors

(3) Other remarks: \_\_\_\_\_

### 4. Specification requirements

(1) Measuring range:  \_\_\_\_\_

(2) Output signal:  4-20 mA DC

(3) Detector mounting:  Immersion  Flow  Direct insertion

(4) Sensor cable length:  5 m  10 m

(5) Extension cable length:  5 m  10 m  20 m  30 m  40 m

(6) Other remarks: \_\_\_\_\_