

General Specifications

EXA SC

Model SC202G 2-wire Conductivity or Resistivity Transmitter

GS 12D08B02-01E

Flexibility, reliability and low maintenance are among the benefits provided by the EXA SC202 2-wire conductivity transmitter. Designed to meet the exacting requirements of measuring conductivity and resistivity in the modern industrial environment, it contains many features to ensure the best precision whatever the application.

This 2-wire transmitter is housed in a robust IP65 field mountable case. The mA output, digital communication, HART, and a clear LCD make the SC202 a complete industrial analyzer.

A wide variety of temperature compensation possibilities (NaCl according to IEC 60746-3, manual TC, preprogrammed matrices and a free programmable 5x5 matrix), provide a high-accuracy measurement with minimum effort.

The addition of a USP<645> as issued in ed. 23 pure water monitoring feature makes the SC202 ideal for the pharmaceutical industry.



■ FEATURES

- Universal conductivity/resistivity, software switchable
- On-line sensor checking
- Event logbook in software
- Matrix temperature compensation for pure water applications
- Password protection for all levels of software
- Easy to use EXA control panel
- Pharmaceutical pure water monitoring (USP<645> as issued in ed. 23.)
- HART®, PROFIBUS-PA, FOUNDATION Fieldbus H1 communications

■ ACCURATE MEASUREMENT

● Electrode selection

In order to make precise conductivity or resistivity measurements, there are a number of prerequisites. Most important is the selection of suitable sensors. Special attention should be paid to the choice of the sensors to ensure compatibility with both the chemical composition and the specific conductivity of the fluid to be measured. The installation of the sensor is also very important for a correct measurement. Other Yokogawa specification sheets cover the choice of sensors and holders, and any Yokogawa sales office can provide expert advice.

NOTE:

In the case of applications using highly conductive fluids, inductive conductivity measurement should be considered as an alternative because of lower maintenance requirements.

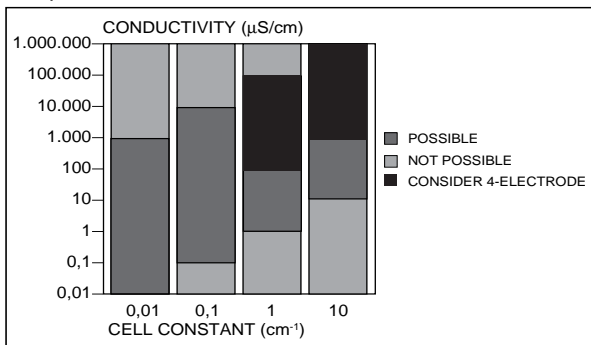

Measuring range as function of the cell constant

NOTE:

With 2-electrode systems some polarization may decrease the measured conductivity value at higher concentrations.

● Fault diagnosis

The measurement is continuously checked for faults, giving warning of breakage, non-immersion, fouling and cable problems. These faults are signalled by the FAIL flag and can be transmitted to the control room by a current of 21 mA, or 3.6 mA (3.9 mA when HART comm. is used). The fault is also signalled by a special marker field in the display, and an error code in the message display.

● Transmitter design

The system is designed to minimize the effect of external influences.

Signal processing ensures that only changes in conductivity cause changes in the output. That is why EXA instruments offer a wide range of temperature compensation possibilities.

● USP Monitoring

The SC202 monitor water quality according to the USP<645> as issued in ed. 23 directive (United States Pharmacopeia). Both compensated and uncompensated conductivity values can be read from the display, as can the solution temperature. There is an error message (E13) alarm to indicate that the USP<645> as issued in ed. 23 limit is exceeded. USP<645> as issued in ed. 23 determines a level of uncompensated conductivity for each temperature. The water must be below this level to be acceptable. This curve is preprogrammed into the SC202 and is used in the setpoint calculations.

■ PROCESS TEMPERATURE COMPENSATION

● Automatic, according to NaCl tables (IEC 60746-3 tables)

From the factory, the SC202 are configured for non-linear temperature compensation according NaCl tables which will give accuracy in most measurements. In this case no site adjustments are required. For applications where NaCl compensation is not sufficient, other compensation possibilities are presented below.

● Matrix

The SC202 are equipped with a matrix type algorithm (conductivity as a function of concentration and temperature) for accurate temperature compensation in various applications.

For pure water applications the following choices can be made:

- HCl (cation) compensation (0 - 80 °C)
- Ammonia compensation (0 - 80 °C)
- Morpholine compensation (0 - 80 °C)

For higher conductivity ranges the choices are:

- HCl (1 - 5 %, 0 - 60 °C)
- NaOH (1 - 5 %, 0 - 100 °C)
- 25 points (5 x 5) user programmable matrix.

This matrix can easily be programmed from the service mode by entering 5 temperature points, followed by conductivity values for each concentration at the 5 temperatures.

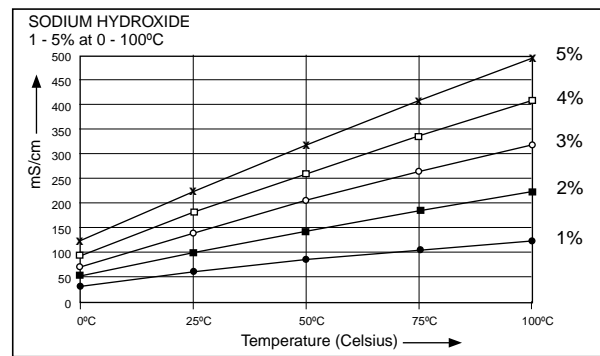

Example of matrix temperature compensation

● Manual Temperature coefficient

It is also possible to have a linear compensation with programmable coefficient. A second conductivity display with independent TC is possible.

At start-up a known temperature coefficient may be entered from the service mode, or the TC can be adjusted by calibration, using actual process solutions. The freely programmable reference temperature also contributes to a high accuracy measurement.

■ SIGNAL PROCESSING

With the correct sensor configuration it is possible to measure either conductivity or resistivity.

OUTPUT SIGNAL

The standard SC202 features a 4-20 mA current output available for recording, and indication or control functions. The user selectable application can represent:

- the measured conductivity value
- the measured resistivity value

In addition the following output functions are available:

- a "HOLD" function that maintains last measured process value or a fixed value until return to normal operation
- a "BURN" function that gives a high, low or pulsed output at fail status
- a programmable output function that allows the user to linearize the output when used as a concentration analyzer.

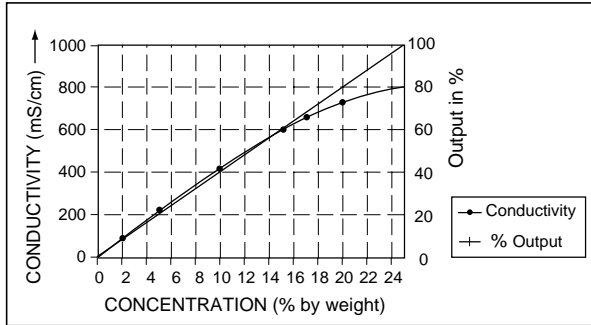

F04.EPS

Linearization of output
Example: 0-25% Sulfuric acid

Code Output	mA 4-20	Conc.	Example % H ₂ SO ₄	Cond.	Example mS/cm
0	4		0		0
5	4.8		1.25		60
10	5.6		2.5		113
15	6.4		3.75		180
20	7.2		5		211
25	8		6.25		290
30	8.8		7.5		335
35	9.6		8.75		383
40	10.4		10		424
45	11.2		11.25		466
50	12		12.5		515
55	12.8		13.75		555
60	13.6		15		590
65	14.4		16.25		625
70	15.2		17.5		655
75	16		18.75		685
80	16.8		20		718
85	17.6		21.25		735
90	18.4		22.5		755
95	19.2		23.75		775
100	20.0		25		791

T01.EPS

THREE LEVEL OPERATION

The EXA SC202 transmitter uses a 3-level operating system to take full advantage of the microprocessor while retaining the traditional simplicity of analog converters. Advanced functions are separated from conventional operation to avoid confusion. They can be activated as required for each individual application.

1. The normal maintenance functions are accessible

through the flexible window by pushing the keys underneath.

2. Functions required to commission the instrument are hidden to discourage unauthorized tampering. The front cover is removed to reveal the commissioning menu and the hidden access key (marked*).
3. Specialized functions can be adjusted via the SERVICE menu. In this case access is by using "service codes".

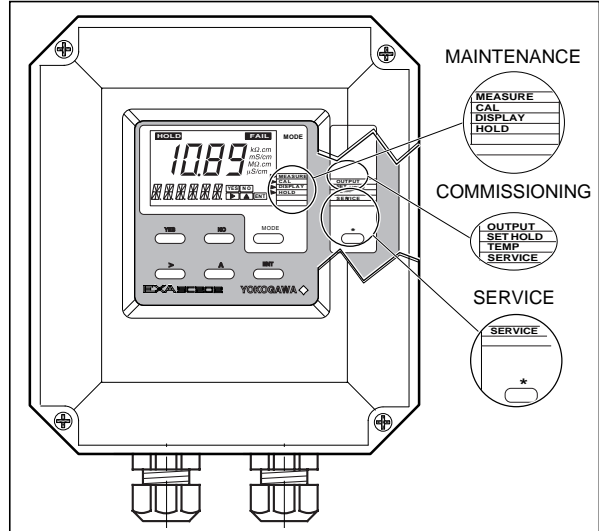

F05.EPS

Three level operation

MAINTENANCE level

- Use : Normal operation and checking
- How : Simple operation by dialog through the closed front cover
- Example : Read secondary data displays

COMMISSIONING level

- Use : For normal commissioning
- How : Removal of the front cover reveals the access key and second menu
- Example : Output range setting

SERVICE level

- Use : Only for specialised functions
- How : Through special service code entries
- Example : Selecting process compensation

With this 3-level user-friendly approach, the instrument can be operated by anyone. Commissioning is straight-forward and needs no calibration equipment compared to analog instruments. Special functions available via access codes are invisible during normal operation. All three levels can be separately protected against unauthorized access by a password system using a three digit code.

HART COMMUNICATION

One of the features of smart field devices is their ability to detect faults, either in the device electronics or in an associated sensor. Using a fieldbus system, such faults are reported in the device status byte in every message (assuming that communication is still possible!). For HART, it is still useful to follow the convention of indicating fault conditions by setting the analogue output current to a value which is recognizably beyond the normal operating range (including the small amount of linear over-range commonly allowed). If it is still alive, the current output

value is set to an appropriate value with the intention that a host system should be able to set alarm thresholds just outside the normal 4 to 20 mA range, to indicate measurement out-of-range, and to set further alarm thresholds to indicate a fault condition.

DD specification and other support files

The SC202 Device Description (DD) files are available enabling communications compatible HOST devices (and HHT for HART). Other files to support AMS, PRM and PDM are available as well. For more information contact your local Yokogawa sales offices.

1. GENERAL SPECIFICATIONS

1.1 Specification

A. Input specifications

: Two or four electrodes measurement with square wave excitation.
Cell constant from 0.008 to 50.0 cm⁻¹

B. Detection method

: Frequency, read-pulse position and reference voltage are dynamically optimized.

C. Input ranges

- Conductivity

Minimum : 0 μS / cm
Maximum : 200 mS x (Cell constant)
(overrange 1999 mS / cm).

- Resistivity

Minimum : 0.005 kΩ / (Cell constant)
Maximum : 999 MΩ x cm

- Temperature

Pt1000 : -20 to +250 °C (0 - 500 °F)
Pt100 and Ni100 : -20 to +200 °C (0 - 400 °F)
8.55kΩ NTC : -10 to +120 °C (10 - 250 °F)
PB36 NTC : -20 to +120 °C (0 - 250 °F)

D. Output Span

- Conductivity

: - min. 0.01 μS/cm,
- max. 1999 mS/cm. (max 90% zero suppression)

- Resistivity

: - min. 0.001 kΩ·cm
- max. 999 MΩ·cm. (max 90% zero suppression)

E. Transmission Signals

: Isolated output of 4-20 mA DC.
Burn up (21 mA) or Burn down (3.6 mA when HART or distributor comm. is non-used, 3.9 mA when HART or distributor comm. is used) or pulse of 21 mA to signal failure.

F. Temperature compensation

: Automatic, for temperature ranges mentioned under C (inputs).
- Reference temp. : programmable from 0 to 100 °C or 30 - 210 °F (default 25 °C).

G. Compensation algorithm

- NaCl : According IEC 60746-3 NaCl tables (default).

- T.C. : Two independent user programmable temperature coefficients, from 0% to 3.5% per °C (°F) by adjustment or calibration.

- Matrix : Conductivity function of concentration and temperature. Choice out of 5 preprogrammed matrixes and a 25-point user-programmable matrix.

H. Logbook

: Software record of important events and diagnostic data. Available through HART link, with diagnostic information available in the display.

I. Display

: Custom liquid crystal display, with a main display of 3 1/2 digits 12.5 mm high. Message display of 6 alpha-numeric characters, 7 mm high. Warning flags and units (mS/cm, kΩ·cm, μS/cm and MΩ·cm) as appropriate.

J. Power supply

: Nominal 24 volt DC loop powered system.
SC202G: 17 to 40 V, see Fig.1

Maximum load resistance

For the SC202G, see Fig. 1
200Ω or less with the PH201G
50Ω or less with the SDBT

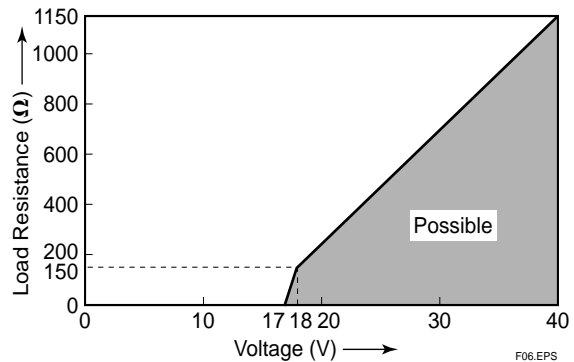

Fig.1 Supply voltage/ load diagram for the SC202G

K. Input isolation : 1000 VDC

L. Weight

Body weight : approx. 1.6 kg
Mounting brackets weight : approx. 0.7 kg

1.2 Operating specifications

A. Performance (under reference conditions with sensor simulation)

- Conductivity (2 μS x K cm⁻¹ to 200 mS x K cm⁻¹)
 - Accuracy : ±0.5%F.S.
- Conductivity (1 μS x K cm⁻¹ to 2 μS x K cm⁻¹)
 - Accuracy : ±1%F.S.
- Resistivity (0.005kΩ / K cm⁻¹ to 0.5MΩ / K cm⁻¹)
 - Accuracy : ±0.5%F.S.
- Resistivity (0.5MΩ / K cm⁻¹ to 1MΩ / K cm⁻¹)
 - Accuracy : ±1%F.S.
- Temperature (Pt1000, PB36 NTC, Ni100)
 - Accuracy : ±0.3°C
- Temperature (Pt100, 8.55kΩ NTC)
 - Accuracy : ±0.4°C
- Temperature compensation
 - NaCl table : ±1 %
 - Matrix : ±3 %

Note: "F.S." means maximum setting value of transmitter output. "K" means cell constant. YOKOGAWA provides conductivity sensors which cell constant are 0.1 to 10 cm⁻¹.

The following tolerance is added to above performance.

mA output tolerance: ± 0.02 mA of "4 - 20 mA"

- Step response : 90 % (< 2 decades) in 7 seconds

B. Ambient operating temperature : -10 to +55°C (10 to 130 °F)

Storage temperature : -30 to +70°C (-20 to 160 °F)

C. Humidity : 10 to 90% RH non-condensing

D. Housing : Cast aluminium case with chemically resistant coating, cover with flexible polycarbonate window. Case color is off-white (Equivalent to Munsell 2.5Y8.4/1.2) and cover is Deepsea Moss green (Equivalent to Munsell 0.6GY3.1/2.0). Cable entry is via two PG13.5 nylon glands. Weather resistant to IP65, NEMA 4X and Type 3S standards. Pipe wall or panel mounting, using optional hardware.

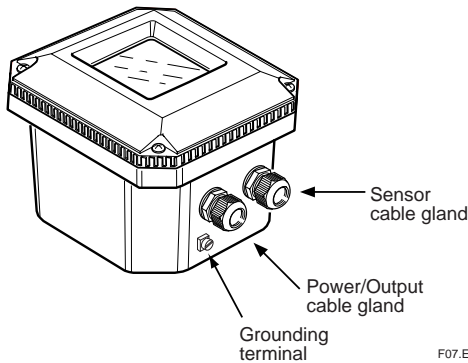

E. Cable and terminals :

The glands will form a tight seal on cables with an outside diameter in the range of 6 to 12 mm.

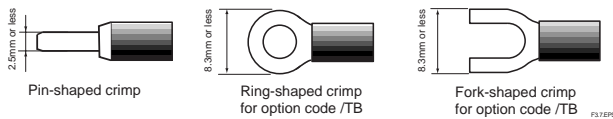

Requirement of connecting with external instruments

	Terminal for pin cable terminal	Screw terminal (option /TB)
Crimp contact for cable	Pin-shaped crimp contact with sleeve insulator	Ring-shaped or fork-shaped crimp contact
Usable contact	max. 2.5 mm	Crimp contact shown as the figures under this table, which meets M3 screw
Torque for fixing	0.5 N·m or less	1.35 N·m (recommended)
Example of crimp contact*	Weidmuller Co., Ltd. made: H0.34/10, H0.5/12, H1/12, H1.5/12S	JST, Mfg. Co., Ltd. made: VD1.25-3(Ring shape), VD1.25-S3A(Fork shape)

*Note: Other crimp contact may be required, depending on core-cable diameter.

F. Data protection : EEPROM for configuration and logbook

G. Automatic safeguard

: Return to measuring mode when no keystroke is made for 10 min.

H. Operation protection

: 3-digit programmable password.

I. EMC Conformity standards (SC202G) ,

EN 61326-1 Class A, Table 2 (For use in industrial locations)

EN 61326-2-3

EN 61326-2-5 (Profibus communication may be influenced by strong electromagnetic field.)
Korea Electromagnetic Conformity Standard

1.3 HART® communications

Input : Two-wire system, 4-20 mA DC

Power supply : SC202G : up to 40 volts
SC202S ,SJ: up to 31.5 volts

Note: The transmitter contains a switched power supply, drawing its energy from the 0-4 mA section of the signal. Consequently the 17 volt limit is applied at 4 mA. The characteristic of the unit is such that above about 7 mA on the output, the terminal voltage can drop to 14.5 volts without problem.

Transmission Signal : Isolated output of 4 to 20 mA DC.

: Maximum load 425Ω at 24 VDC
Burn to signal failure acc. NAMUR Recommendation NE43 (18.01.1994)

Operating range : 3.9 to 21 mA

Communication : HART®, 1200 Baud, FSK modulated on 4 to 20 mA signal

Configuration Software : Local with 6 keys
: Firmware based on Yokogawa stack.

Hardware : Yokogawa HART Modem F9197UB

Other Control systems : Yokogawa PRM, Rosemount AMS, Siemens PDM

Hand Terminal : Rosemount HHT 275/375

Output span :

- **Conductivity** : min 0.01 μS/cm, max. 1999 mS/cm. (max 90% zero suppression)

- **Resistivity** : min 0.001kΩ·cm, max. 999 MΩ·cm. (max 90% zero suppression)

The instrument is user programmable for linear or non-linear conductivity ranges.

Cable specification: 0.5 mm diameter or 24 AWG over maximum length of 1500 m

DD specification : The SC202 Device Description is available enabling communications with the Handheld communicator and compatible devices.

1.4 PROFIBUS-PA communications

Input signal: Digital

Supply voltage: 9 to 32 V DC

Operating current: 26.0 mA

Operating values: According to IEC 1158-2

Bus connection: Fieldbus interface based on IEC 1158-2 according to FISCO-Model

Power supply: Power supply is achieved dependant on the application by means of segment coupler

Data transfer: According to PROFIBUS- PA profile class B based on EN 50170 and DIN 19245 part 4

GSD file: The actual file can be downloaded from www.profibus.com

Configuration: Local with 6 keys

Software: Firmware based on Siemens DPC31 stack.

Hardware: PC- or PCMCIA-interfaces from Siemens

Other control: Siemens PDM systems

Electrical connection: Terminals acc. to IEC 1158-2

Fieldbus-cable-types: Twisted and shielded two wire cable according to recommendation based on IEC 1158-2

Cable diameter: 6 to 12 mm (0.24 to 0.47 inch)

1.5 FOUNDATION Fieldbus H1 communications

Input signal: Digital

Supply voltage: 9 to 32 V DC

Operating current: 26.0 mA (base current)

Operating values: According to IEC 1158-2

Bus connection: Fieldbus interface based on IEC 1158-2 according to FISCO-Model

Power supply: Power supply is achieved dependant on the application by means of segment coupler

Data transfer: FF Specification Rev. 1.4, Basic device

Function blocks: 3xAI, Transducer, Resource

Files: Actual file can be downloaded from our homepage

Configuration: Local with 6 keys,

Software: National Instruments, NI-FBUS configurator

Hardware: FBUS-interfaces from National Instruments (AT-FBUS and PCMCIA FBUS)

Other control systems: Yokogawa PRM, DMT

2. DISTRIBUTOR: PH201G (Style B)

The PH201G supplies drive power to 2-wire transmitter. The PH201G receives a 4-20 mA DC current signal from the transmitter, and converts the signal to a 1-5 V DC voltage signal. Simultaneously, it also receives a digital signal superimposed on the 4-20 mA DC current signal, and provides as outputs a hold-contact signal and a fail-contact signal. In addition, the PH201G has a built-in current regulator so that it will not supply an excess current even if the circuit or the power supply cable on the transmitter shorts.

<Input/Output Signal Specifications>

Number of input points
(Number of transmitter units connectable)
: 1 point

Output signal : 1 to 5 V DC (2 points)

Load resistance : 2 kΩ or less (1 to 5 V DC Output)

Isolation system : Loop isolation type
Between input and output is No isolation
Between input/output and power supply is Isolated

<Mounting / Form>

Mounting method : Indoor rack mounting

Connection method : External signal connection
: M4 screw terminal connection

Power supply / Ground connection :
100V : JIS C8303 ground type 2 plug connection or M4 screw terminal connection (option: /TB)

220V : CEE 7VII (European electrical device standard) plug connection

Cable length : 300 mm

External dimensions : 180H x 48W x 300D mm

Weight : Approx. 1.7 kg (Including rack and case)

<Standard Specifications>

Accuracy : ±0.2 % of span

Transmitter supply voltage :
: 26.5 ± 1.5 V DC

Maximum current and power consumption
24 V DC : Approx. 4.8 W
100 V AC : Approx. 7 VA
220 V AC : Approx. 11 VA

Insulation resistance
Between I/O terminals and ground pin : 100 M Ω / 500 V DC
Between power supply pins and ground pin : 100 M Ω / 500 V DC

<Operating Specifications>

Ambient temperature : 0 to 50 °C

Ambient humidity : 5 to 90% RH (Non-condensing)

Power supply : Dual use AC/DC
100 V : DC power 20 to 130 V, no polarity AC power 80 to 138 V, 47 to 63 Hz

220 V : DC power 120 to 340 V, no polarity AC power 138 to 264 V, 47 to 63 Hz

<Contact Output>

Contact rating : 250 V AC, maximum 100 VA
220 V DC, maximum 50 VA

Hold contact output : N.C. 1 contact, Normally energized
Contact closes when power is off or during maintenance.

Failure contact output : N.C. 1 contact, Normally energized
Contact closes when power is off or during failure.

System Configuration Example

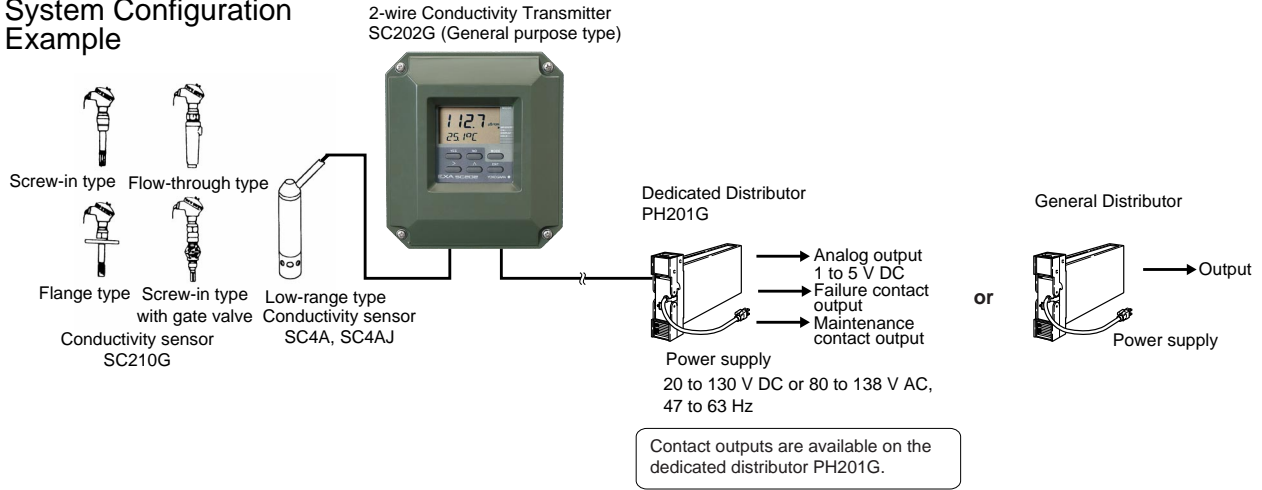

MODEL AND SUFFIX CODES

1. 2-wire Conductivity transmitter (Non-explosionproof type)

[Style : S3]

Model	Suffix Code	Option Code	Description
SC202G	2—wire conductivity transmitter
Type	-A -P -F	mA with HART Profibus FF
Language	-J -E	Japanese English
Option Mounting Hardware		/U /PM Hood /H /H2 Tag Plate /SCT Conduit Adapter /AFTG /ANSI /TB /X1	Pipe, wall mounting bracket (Stainless steel) Panel mounting bracket (Stainless steel) Hood for sun protection (Carbon steel) Hood for sun protection (Stainless steel) Stainless steel tag plate G1/2 1/2NPT Screw terminal (*1) Epoxy baked finish (*2)

(*1) It can be specified when the suffix code -A is selected.

(*2) The housing is coated with epoxy resin.

T02.EPS

2. Dedicated distributor

Model	Suffix Code	Option Code	Description
PH201G	Distributor
Power Supply	-A1 -A2	100V AC 220V AC
—	*B	Style B
Option		/TB	Terminal for power connection

T04.EPS

■ DIMENSIONS

Unit : mm

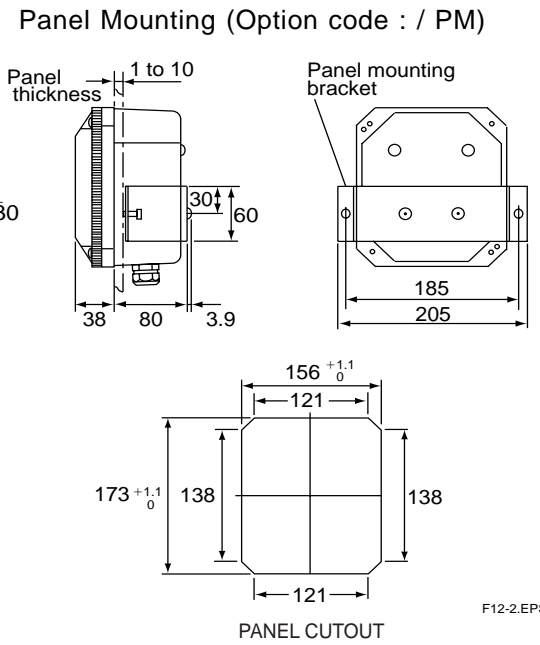
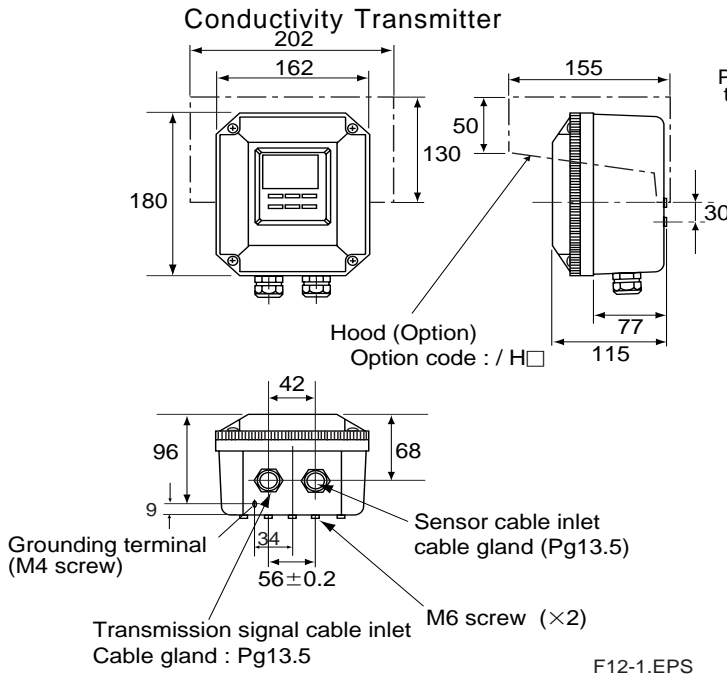

Conduit Adapter (Option)

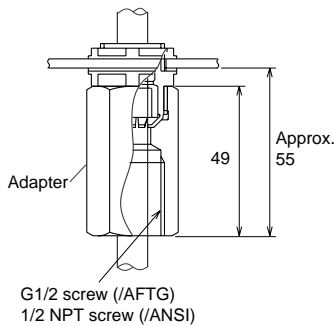

Panel Mounting when using two (2) self-taping screws

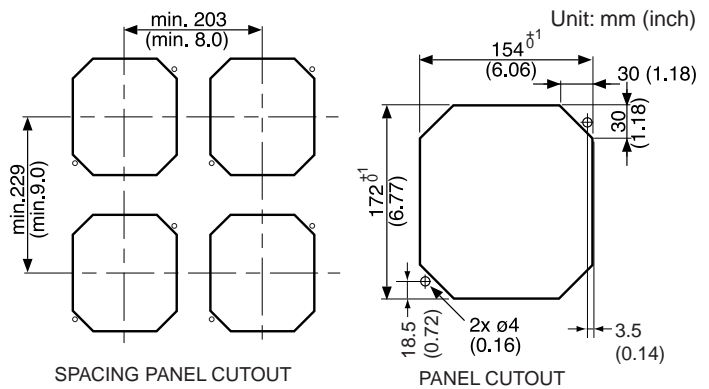

Pipe / Wall Mounting (Option code : / U)

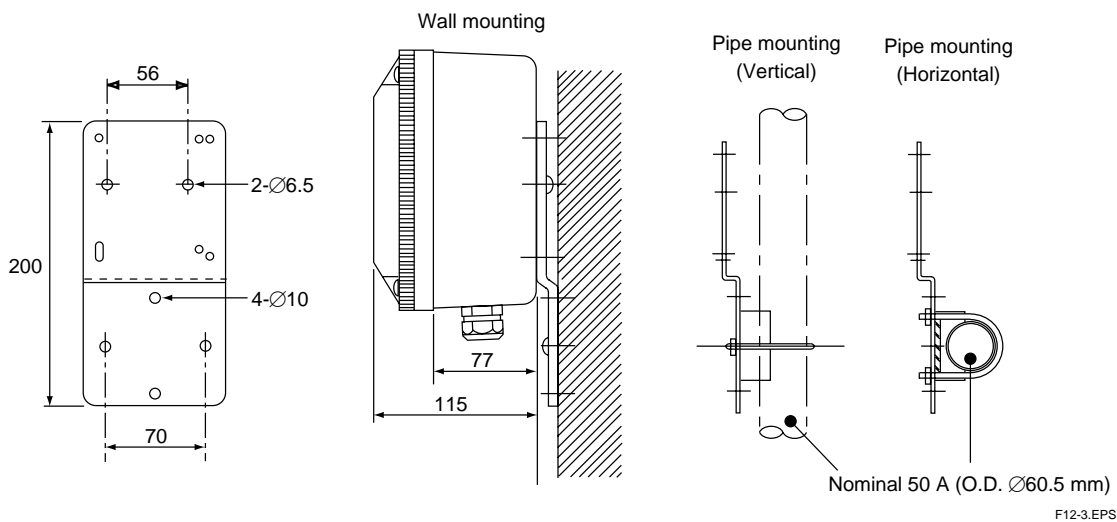

PH201G Distributor (Style B)

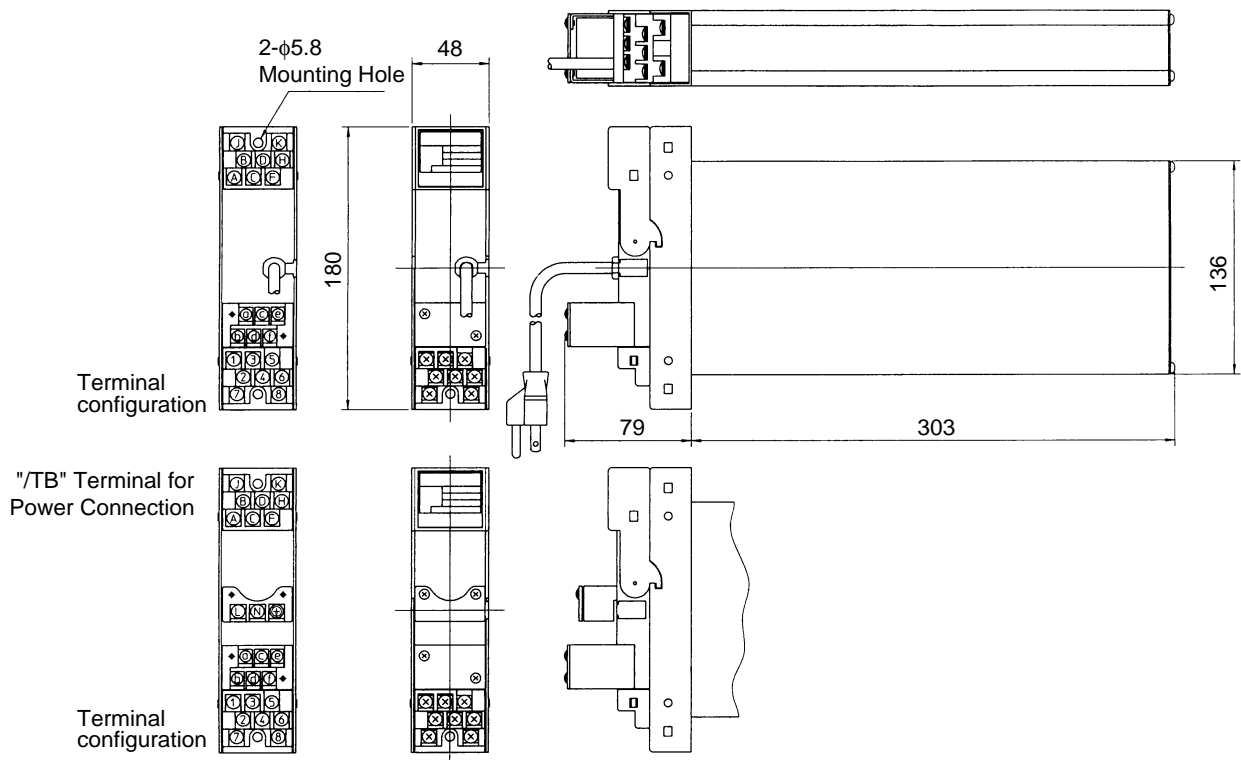

F13-1.EPS

EXTERNAL WIRING

Connection Diagram

1. Example of Non-Explosionproof System

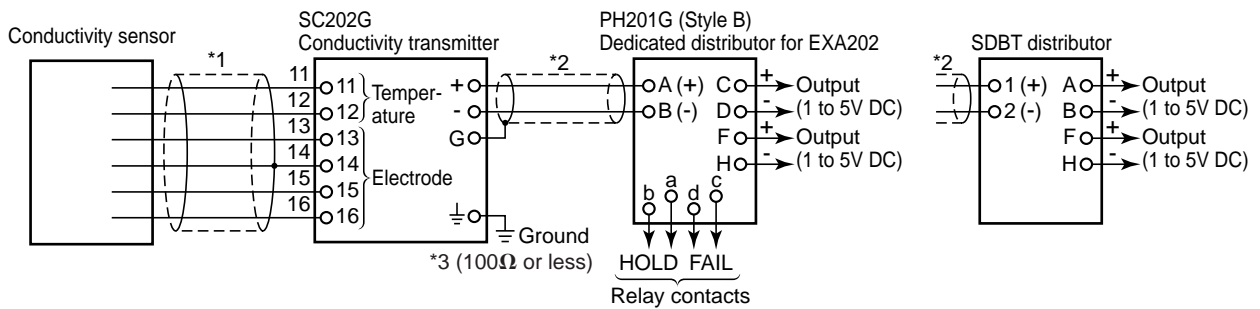

F08.EPS

*1 : This cable is specified by the additional code of a conductivity sensor, or a sensor cable.

*2 : Use a two-conductor shielded cable of OD 6 to 12 mm.

The cable length is : Max. 2000 m (also the minimum operating voltage of conductivity transmitter must be obtained)

*3 : Conduct grounding without fail on the conductivity transmitter
(Grounding resistance : 100Ω or less)

Inquiry Specifications for 2-wire Conductivity Transmitter System

Make inquiries by filling in related boxes with checks (✓) and writing in the underlined parts.

1. General Items

Name of your company: _____
 Person in charge: _____ Belongs to: _____ (Phone No. _____)
 Name of plant: _____
 Measuring point: _____
 Purpose of use: Indication Record Alarm Control
 Power supply to Distributor: _____ V AC

2. Measuring Conditions

(1) Liquid temperature: _____ to _____ , Normal _____ [°C]
 (2) Liquid pressure: _____ to _____ , Normal _____ [kPa]
 (3) Flow rate: _____ to _____ , Normal _____ [l / min.]
 (4) Flow speed: _____ to _____ , Normal _____ [m / s]
 (5) Slurry or fouling components: No Yes
 (6) Name of measuring liquid: _____
 (7) Components of measuring liquid: _____
 (8) Others: _____

3. Installing Location

(1) Ambient temperature: _____
 (2) Installing location: Outdoors Indoors _____
 (3) Others: _____

4. Specification Requirements

(1) Measuring range: _____
 (2) Transmission output: 4 to 20 mA DC HART® PROFIBUS-PA FOUNDATION Fieldbus H1
 (3) Detector: _____
 (4) Detector mounting: Screw-in Flow-through Flange Immersion
 (5) Sensor cable length: _____ m
 (6) Others: _____