

GS 12D08G02-E

■ GENERAL

YOKOGAWA has been supplying superior on-line analyzers for monitoring or controlling the conductivity of liquid or solutions.

Now, YOKOGAWA provides the four-wire conductivity converter, (SC450G), the two-wire conductivity transmitter (FLXA21, SC202).

YOKOGAWA also provides many kinds of detectors/sensors for accurately measuring liquid conductivity when using converters/transmitters.

The combination of YOKOGAWA's converters/transmitter and detectors/sensors meets the demanding ultrapurewater requirements of the growing semiconductor and pharmaceutical markets in addition to traditional water quality measurements for standard power plant and chemical applications.



F01.EPS



F02.EPS



F03.EPS



F07-1.EPS

Refer to GS 12D08N05-01E



Refer to GS 12A01A02-01E



F07.EPS

Refer to GS 12D08B02-E

■ Models of Conductivity Detectors/Sensors

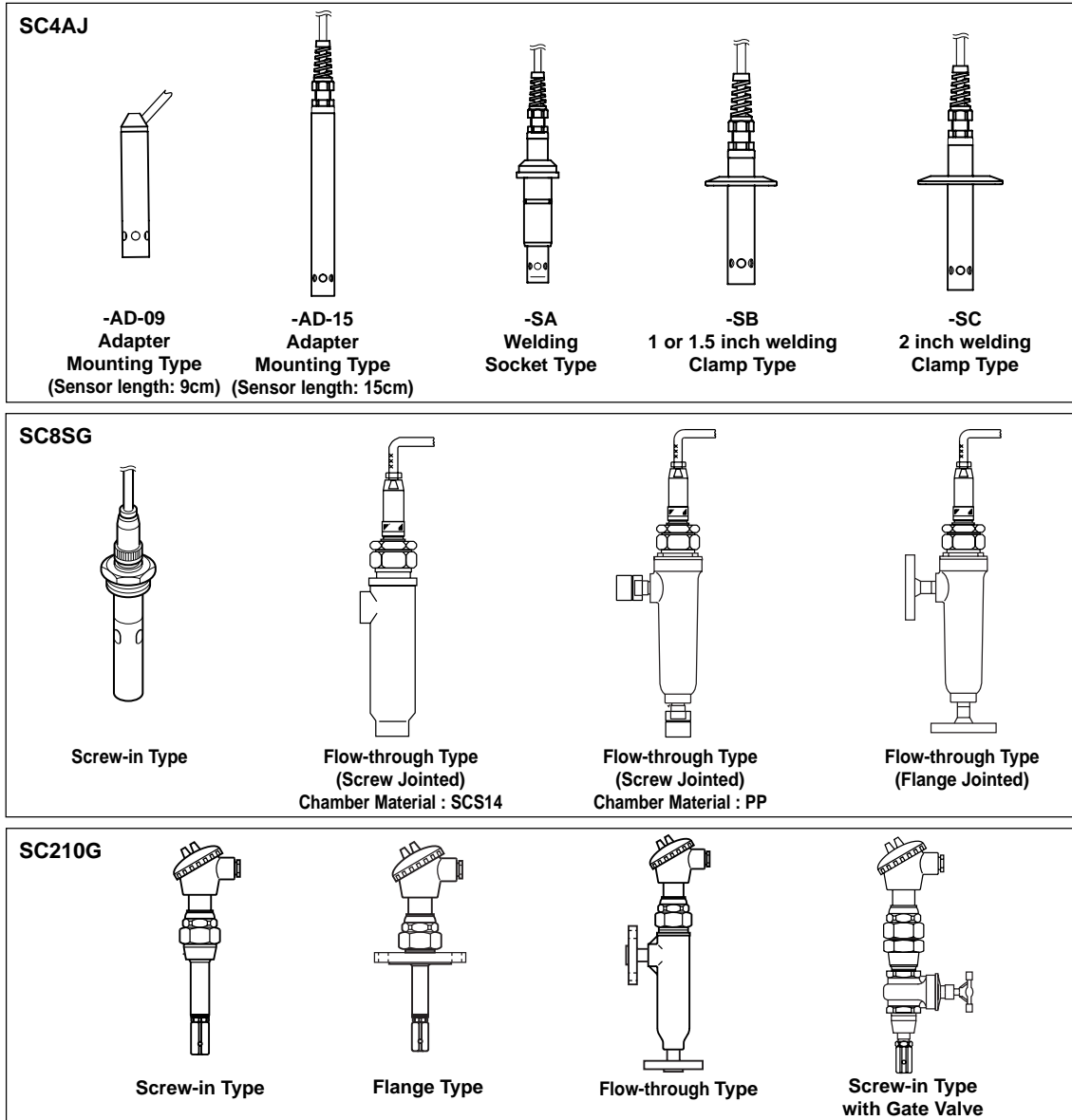

F08.EPS

■ RANGE OF MEASURING UPPER RANGE LIMIT OF EACH SENSORS

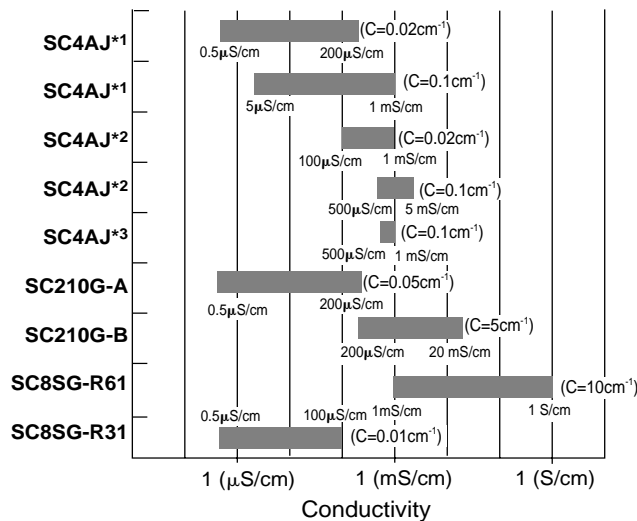

NOTE:

The bar graph at the left shows the range of the upper range limit of each sensor. For example, in the case of SC8SG-R61, the measuring range is from 0-1 mS/cm to 0-1 S/cm. In measurement in high conductivity range, polluted solution may affect measured values of any sensors. C represents cell constant.

Note that when used in combination with the SC100 converter, the SC4AJ sensor has different measuring range depending on the material and so forth.

*1 : In case of the combination with the SC450G, FLXA21, SC202G, or SC202SJ

*2 : In case of the combination with the SC100 (Titanium)

*3 : In case of the combination with the SC100 (SUS)

F09.EPS

GENERAL SPECIFICATIONS

1. SC4AJ:

Cable with pin terminals (applicable to SC100, FLXA21, SC202G and SC202SJ)

Cable with M3 ring terminals (applicable to SC450G, SC202□/TB)

Cable with M4 ring terminals (applicable to FLXA21)

Object of measurement:

Conductivity of solutions

Measuring principle: Two-electrode system

Cell constant : 0.02cm⁻¹, 0.1cm⁻¹

Measuring range :

For a cell constant: 0.02cm⁻¹

In case of the combination with the SC450G, FLXA21, SC202G or SC202SJ:
0 - 0.5 μS/cm to 0 - 200 μS/cm

In case of the combination with the SC100:
0 - 100 μS/cm to 0 - 1 mS/cm
(Material: Titanium only, SC100 can not use with SC4AJ sensor made of SUS which cell constant is 0.02 cm⁻¹.)

For a cell constant: 0.1cm⁻¹

In case of the combination with the SC450G, FLXA21, SC202G or SC202SJ:
0 - 5 μS/cm to 1 mS/cm

In case of the combination with the SC100:
0 - 500 μS/cm to 0 - 5 mS/cm
(Material: Titanium)

In case of the combination with the SC100:
0 - 500 μS/cm to 1 mS/cm (Material: SUS)

Temperature Range: For electrode, 0 to 110°C
For holder, see Figure 1

Sterilization for electrode:

135°C (275°F), within 30 minutes in Steam Sterilization

Pressure range : For electrode, 0 to 1 MPa
For holder, see Figure 1

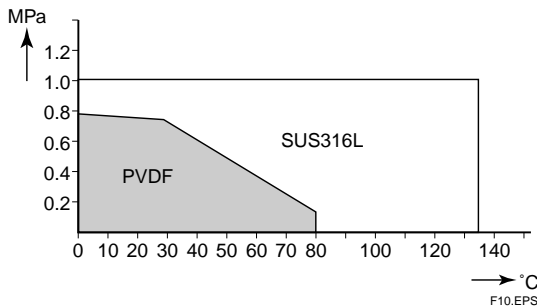

Figure 1 The range of tolerance of holders (option: /PS, /PF, /RS, /RF, /SA1, /SA2, /SB1, /SB2, /SC1) for temperature and pressure

Sample solution condition:

Although flow rate is not limited in measurement, air bubbles should not be mixed in the sample solutions to obtain correct measured values.

Temperature sensor: Pt1000

Materials

Body & Electrode : SUS316L (for all Fitting-type) or Titanium (only for adapter mounting type-AD), Viton O-ring

Isolator : PEEK

Mounting adapter : Polyvinylidene difluoride (for /PF and /RF) or SUS316L (for the others)

Weight:

Sensors:

Adapter mounting type

(SC4AJ-S-AD-09-002-05): approx.450 g

Adapter mounting type

(SC4AJ-S-AD-15-002-05): approx.520 g

Welding socket type

(SC4AJ-S-SA-NN-002-05): approx.670 g

1 or 1.5 inch welding clamp type

(SC4AJ-S-SB-NN-002-05): approx.550 g

2 inch welding clamp type

(SC4AJ-S-SC-NN-002-05): approx.670 g

(Note) There are weight differences among SC4AJ sensors. In order to know the more accurate weight of each type of sensors, please calculate it from following information. The cable weighs 75 g/m. The SC4AJ with 0.02cm⁻¹ cell constant is 15 gram heavier than the SC4AJ with 0.1cm⁻¹ cell constant. SUS314L electrode is 40 g heavier than Titanium electrode.

Adapters:

3/4NPT stainless steel adapter (/PS)

:approx. 110 g

R3/4 stainless steel adapter (/RS):approx. 110 g

3/4NPT PVDF adapter (/PF) : approx. 35 g

R3/4 PVDF adapter (/RF) : approx. 35 g

Straight welding socket (/SA1) : approx. 300 g

Angle welding socket 15 (/SA2) : approx. 320 g

Welding clamp 1 inch (/SB1) : approx. 330 g

Welding clamp 1.5 inch (/SB2) : approx. 305 g

Welding clamp 2 inch (/SC1) : approx. 350 g

(note) Do not submerge the sensor itself in process water, as the seams between the mold and the metal of the sensor are not waterproof.

2. SC8SG:

Cable with pin terminals (applicable to FLXA21, SC202G and SC202SJ)

Cable with M3 ring terminals (applicable to SC450G,)

Cable with fork terminals (applicable to SC202G and SC202□/TB)

Cable with M4 ring terminals (applicable to FLXA21)

Object of measurement:

Conductivity of liquids

Measuring Principle: 2-electrode system or 4-electrode system

Cell Constants : 0.01 cm⁻¹ or 10 cm⁻¹
(for two-electrode system)
10 cm⁻¹ (for four-electrode system)

Measuring Ranges : 0 - 0.5 μS/cm to 0 - 100 μS/cm for a cell constant of 0.01 cm⁻¹
0 - 1 mS/cm to 0 - 1000 mS/cm for a cell constant of 10 cm⁻¹

Temperature Range: 0° to 100°C (130°C maximum only for 0.01 cm⁻¹ cell constant detectors, excluding those with polypropylene chambers)

Pressure : 1000 kPa max. (500 kPa maximum for detectors with polypropylene chambers)

Flow rate of Sample Solution:

No particular limitation applies, although a value of less than 20 l/min. is recommended for flow-through detectors.

(Note) No limitation applies to flow rate (flow velocity) as far as measurement is concerned. Take care, however, when using flow-through detectors. Electrodes or the inner walls of a liquid chamber may wear put drastically at higher flow speeds if a measured solution contains slurry. Air bubbles should not be mixed in the sample solutions to obtain correct measured values.

RTD for Temperature Compensation:
Pt1000 (built into the sensor)
Construction : Rainproof encapsulation (compatible with the JIS C0920 Japanese Industrial Standard)

Weight :
Screw-in type
approximately 1.3 kg (excluding the cable)
Flow-through type (SCS14 chamber)
approximately 3.1 kg (excluding the cable)
Flow-through type (SCS14 chamber, flanged)
approximately 4.5 kg (excluding the cable)
Flow-through type (polypropylene chamber)
approximately 2.7 kg (excluding the cable)
Flow-through type (polypropylene chamber, flanged)
approximately 3.2 kg (excluding the cable)

Cable
0.3 kg for 5.5-m length; 0.5 kg for 10-m length; 0.9 kg for 20-m length.

Process Connection: Screw-in or flow-through

Construction of Wetted Part:

- Sensor-holding base:
SUS316 and fluoro-rubber when using screw-in type holder or the chamber made of stainless steel. PP and fluoro-rubber when using the chamber made of PP.
- 0.01 cm⁻¹ cell constant, two-electrode sensor:
SUS316 and ethylene chloride trifluoride
- 10 cm⁻¹ cell constant, two-electrode sensor:
reinforced epoxy resin and graphite
- 10 cm⁻¹ cell constant, four-electrode sensor:
polyvinylidene difluoride, glass and platinum
- Stem (flow-through type):
SCS14 or polypropylene resin

Installation :

- Screw-in type—held by the process piping
- Flow-through type (polypropylene chamber)
—mounted on a pipe (nominal diameter of 50 mm ±2 in.)
- Flow-through type (SCS14 chamber)
—held by the process piping

3. WU41: Dedicated cable for the SC8SG

Cable : Six multicore wire

Applicable transmitter/converter with various detectors

Diameter: 9.2 mm
Material : Thermoplastic PVC

4. SC210G:

Cable with ring terminals (applicable to FLXA21, SC202G/TB and SC202SJ/TB)

Cable with M3 ring terminals (applicable to SC450G, SC202□/TB)

Cable with pin terminals (applicable to FLXA21, SC202G and SC202SJ)

Cable with M4 ring terminals (applicable to FLXA21)

Object of measurement:

Conductivity of solutions

Measuring principle : Two-electrode system

Cell constant : 0.05 cm⁻¹, 5 cm⁻¹

Measuring range : 0 - 0.5 μS/cm to 0 - 200 μS/cm
(Cell constant: 0.05 cm⁻¹)
0 - 200 μS/cm to 0 - 20 mS/cm
(Cell constant: 5 cm⁻¹)

Temperature Range: 0 to 105°C

(chamber material: SCS14)

0 to 100°C

(chamber material:

Polypropylene)

Pressure range : 0 to 1 MPa

(chamber material: SCS14)

0 to 500 kPa

(chamber material: Polypropylene)

Measuring solution condition:

Although flow rate is not limited in measurement, less than 20 l/min is recommended for flow-through type. If slurry is included in sample solutions in flow-through type detectors, the electrode part and the inside of solution chamber may be worn significantly. Air bubbles should not be mixed in the sample solutions to obtain correct measured values.

Temperature sensor: Thermistor (PB36NTC)

Wet part Materials

SC210G-A : For sensor, SUS 316 stainless steel, Viton (O-ring) and Polytrifluorochloroethylene
For body, SUS316 stainless steel, polypropylene and Viton (O-ring)

SC210G-B : For sensor, Platinum, glass and Viton (O-ring)
For body, SUS316 stainless steel, polypropylene and Viton (O-ring)

Construction : JIS C0920 watertight (equal to NEMA 4)

Detector	SC4AJ			SC8SG			SC210G		
	Pin	Ring M4	Ring M3	Pin	Ring M4	Ring M3	Pin	Ring M4	Ring M3
Converter: SC100	Yes	N.A.		N.A.			N.A.		
Transmitter: SC202G, SC202SJ	Yes	N.A.	Yes (Note 1)	Yes	N.A.	Yes (Note 1)	Yes	N.A.	Yes (Note 1)
Converter: SC402G (Note 3)	Yes	N.A.	N.A.	Yes	N.A.	N.A.	Yes	N.A.	N.A.
Converter: SC450G	Note2	N.A.	Yes	Note2	N.A.	Yes	Note2	N.A.	Yes
Analyzer: FLXA21	Yes	Yes	N.A.	Yes	Yes	N.A.	Yes	Yes	N.A.

Note1: Applicable when option code /TB (screw terminal) specified for SC202G/SC202SJ.

Note2: Both pin and M3 ring can be used for SC450G, but M3 ring are recommended.

Note3: SC402G has been terminated.

T07-1.EPS

MODEL AND SUFFIX CODES

1. SC4AJ

Model	Suffix Code	Option Code	Description
SC4AJ	Conductivity sensor
Material	- T - S	Titanium (Only for - AD) SUS316L
Fitting type	- AD - SA - SB - SC	Adapter mounting type Welding socket type *1 1 or 1.5 inch welding clamp type *2 2 inch welding clamp type *2
Sensor length	- 09 - 15 - NN	9 cm (Code for -AD) 15 cm (Code for -AD) fixed length (Code for -SA, -SB, -SC)
Cell constant	- 002 - 010	0.02 cm ⁻¹ 0.1 cm ⁻¹
Cable length	- 03 - 05 - 10 - 15 - 20 - X1 - X2 - X3 - X4 - X5 - Y1 - Y2 - Y3 - Y4 - Y5	3 m (pin terminals) 5 m (pin terminals) 10 m (pin terminals) 15 m (pin terminals) *3 20 m (pin terminals) *3 3 m (M4 ring terminals) *5 5 m (M4 ring terminals) *5 10 m (M4 ring terminals) *5 15 m (M4 ring terminals) *5 20 m (M4 ring terminals) *5 3 m (M3 ring terminals) *6 5 m (M3 ring terminals) *6 10 m (M3 ring terminals) *6 15 m (M3 ring terminals) *6 20 m (M3 ring terminals) *6
Temperature sensor	- T1	Pt1000
Option	For AD only For SA only For SB only For SC only Oil prohibit	/PS /PF /RS /RF /SA1 /SA2 /SB1 /SB2 /SC1 /DG1	3/4NPT adapter SUS316L 3/4NPT adapter PVDF R3/4 adapter SUS316L R3/4 adapter PVDF Straight welding socket SUS316L Angled welding socket 15° SUS316L Welding clamp 1 inch SUS316L Welding clamp 1.5 inch SUS316L Welding clamp 2 inch SUS316L Oil-prohibited use *4

*1: When you select fitting type -SA, place an order on the SC4AJ with option code /SA1 or /SA2.
 *2: When you select fitting type -SB, place an order on the SC4AJ with option code /SB1 or /SB2 (including seal ring),
 When you select fitting type -SC, place an order on the SC4AJ with option code /SC1 (including seal ring).
 *3: Impossible use for the SC400G
 *4: Washing treatment of wet part with alcohol. T01.EPS
 *5: Used for connection to FLXA21. *6: Used for connection to SC450G, SC202□/TB.

Spare parts for SC4AJ

Parts No.	Description
K9670MA	O-ring set for -SA
K9670MK	Seal rings for /SB1 or /SB2
K9670MP	Seal rings for /SC1
K9670MT	3/4 NPT Stainless steel adapter for -AD
K9670MU	3/4 NPT PVDF Adapter for -AD
K9670MV	R3/4 Stainless steel adapter for -AD
K9670MW	R3/4 PVDF Adapter for -AD
K9670MD	Angled welding socket and mounting nut for -SA
K9670ME	Straight welding socket for -SA
K9670MB	Angled welding socket for -SA
K9670MC	Straight welding socket for -SA
K9670ML	Welding clamp 1 or 1.5 inch for -SB
K9670MQ	Welding clamp 2 inch for -SC

T02E.EPS

2. SC8SG

Model	Suffix Code	Option Code	Description	
SC8SG	Conductivity detector	
Measuring range	-R31 -R61	Cell constant: 0.01cm ⁻¹ Cell constant: 10cm ⁻¹	
Electrode configuration	- T - F	2-electrode system (for both 0.01cm ⁻¹ and 10cm ⁻¹ cell constants) - for general measurements *1 4-electrode system (for 10cm ⁻¹ cell constant only) - for countermeasures against polarization due to contamination *2	
Construction	Screw-in model	- 100	with welding socket *3
		- 101	without welding socket (a welding socket [K9208BK] should be ordered separately)
	Flow-through model *7	- 302	Rc1/2 female threaded; chamber material: SCS14
		- 312	Rc1/2 female threaded; chamber material: PP
		- 303	1/2NPT female threaded; chamber material: SCS14
		- 313	1/2NPT female threaded; chamber material: PP
		- 304	JIS 10K 15 RF flange; chamber material: SCS14
		- 314	JIS 10K 15 FF flange; chamber material: PP
- 305	ANSI Class150 1/2 RF flange with serration; chamber material: SCS14		
- 315	ANSI Class150 1/2 FF flange; chamber material: PP		
Cable length		- P1	5.5m (special cable supplied with detector) (pin terminals)
		- P2	10m (special cable supplied with detector) (pin terminals)
		- P3	20m (special cable supplied with detector) (pin terminals)*4
		- F1	5.5m (special cable supplied with detector) (fork terminal)
		- F2	10m (special cable supplied with detector) (fork terminal)
		- F3	20m (special cable supplied with detector) (fork terminal)*4
		- X1	5.5m (special cable supplied with detector) (M4 ring terminal)*5
		- X2	10m (special cable supplied with detector) (M4 ring terminal)*5
		- X3	20m (special cable supplied with detector) (M4 ring terminal)*5
		- Y1	5.5m (special cable supplied with detector) (M3 ring terminal)*6
		- Y2	10m (special cable supplied with detector) (M3 ring terminal)*6
		- Y3	20m (special cable supplied with detector) (M3 ring terminal)*6
Style code	*A	Style A	
Option		/PS /SS	SUS Mounting hardware (for PP chamber) SUS Mounting hardware (for SCS14 chamber)	

- *1 : The cell constant is 0.01cm⁻¹ when the combination of measuring range R31 and Electrode configuration - T is chosen.
The cell constant is 10cm⁻¹ when the combination of measuring range R61 and Electrode configuration - T is chosen.
- *2 : Electrode configuration - F cannot be chosen when R31 is chosen. For process where can give contamination to a detector, a four-electrode detector, the combination of R61 and - F, should be used.
- *3 : If a welding socket (K9208BK) needs to be ordered beforehand, either place a separate order or prepare one by referring to the external view later in this brochure.
- *4 : Impossible use for the SC400G.
- *5 : Used for connection to FLXA21.
- *6 : Used for connection to SC450G, SC202□/TB.
- *7 : The model is not equipped with a mounting hardware, please place an order on the SC8SG with option code /PS or /SS when you select flow-through model.
The PP chamber can have cracks or splits unless it is not supported by a mounting hardware.

T03.EPS

3. WU41

Model	Suffix code	Option code	Description
WU41	Dedicated Cable for SC8SG
Cable end	-F	fork terminals
	-P	pin terminals
	-X	M4 ring terminals *1
	-Y	M3 ring terminals *2
Cable length	-05	5.5 m
	-10	10 m
	-20	20 m

- *1: Used for connection to FLXA21.
- *2: Used for connection to SC450G, SC202□/TB

T13.EPS

Spare Parts for SC8SG

Parts No.	Description
K9208BA	0.01cm ⁻¹ cell constant, two-electrode sensor
K9208BC	10cm ⁻¹ cell constant, two-electrode sensor
K9208BD	10cm ⁻¹ cell constant, four-electrode sensor
K9208BK	Welding socket for screw-in model
G9303EB	O-ring

4. SC210G

T04.EPS

Model	Suffix Code	Option Code	Description
SC210G	Conductivity detector
Measuring range	- A	Low range; cell constant: 0.05cm ⁻¹
	- B	Medium range; cell constant: 5cm ⁻¹
Construction	Screw-in type	- 100 R1-1/2
		- 103 1-1/2NPT male
	Flange type	- 206 JIS 10K 50 RF flange
		- 207 ANSI Class150 2 RF flange (with serration)
		- 208 JPI Class150 2 RF flange
	Flow-through type ^{*1}	- 302 Rc1/2 female, chamber material : SCS14
		- 312 Rc1/2 female, chamber material : PP
		- 303 1/2NPT female, chamber material : SCS14
		- 313 1/2NPT female, chamber material : PP
		- 304 JIS 10K 15 RF flange, chamber material : SCS14
		- 314 JIS 10K 15 FF flange, chamber material : PP
		- 305 ANSI Class150 1/2 RF flange with serration, chamber material : SCS14
		- 315 ANSI Class150 1/2 FF flange, chamber material : PP
With gate valve	- 402 JPI Class150 1/2 RF flange, chamber material : SCS14	
	- 403 R1-1/4 1-1/4NPT male	
Sensor length	- L015	150mm (Standard)
	- L030	300mm ²
	- L050	500mm ²
	- L100	1000mm ²
	- L150	1500mm ²
	- L200	2000mm ²
Cable length	- 03	3m (M4 ring terminals) ^{*4}
	- 05	5m (M4 ring terminals) ^{*4}
	- 10	10m (M4 ring terminals) ^{*4}
	- 15	15m (M4 ring terminals) ^{*4}
	- 20	20m (M4 ring terminals) ^{*3 *4}
	- AA	3m (pin terminals)
	- BB	5m (pin terminals)
	- CC	10m (pin terminals)
	- DD	15m (pin terminals)
	- EE	20m (pin terminals) ^{*3}
	- Y1	3m (M3 ring terminals) ^{*5}
	- Y2	5m (M3 ring terminals) ^{*5}
	- Y3	10m (M3 ring terminals) ^{*5}
	- Y4	15m (M3 ring terminals) ^{*5}
- Y5	20m (M3 ring terminals) ^{*5}	
Style code	*A	Style A
Option		/SCT /ANSI /PF /PS /SS /X1 /DG1 /MCT	Stainless steel tag plate With ANSI connection adaptor ^{*6} DAI-Elperflow (perfluoro-elastomer) specification ^{*7} SUS mounting hardware (for PP construction) SUS mounting hardware (for SCS14 construction) Epoxy-coated (baked) Oil-prohibited use (Degrease cleaning treatment) (except for gate valve) Material Certificate ^{*8} (except for gate valve)

*1: The model is not equipped with a mounting brackets, place an order on the SC210G with option code /PS or /SS when you select flow-through model. The PPchamber material can have cracks or splits unless it is not supported by a mounting hardware.

*2: Only for Screw-in type and Flange type

*3: Impossible use for the SC400G

*4: Used for connection to FLXA21.

*5: Used for connection to SC450G or SC202/TB.

*6: Adaptor for cable inlet (carbon steel)

*7: Materials fo O-ring of electrode assembly and chamber seal become perfluoro-elastomer

T05.EPS

But, in construction -402 and -403, the sealing part of gate valve doesn't become the elastomer

*8: Additional lead time is required.

Spare Parts for SC210G

Parts No.	Description
K9208EA	150mm electrode Assembly (C=0.05cm ⁻¹) for SC210G-A
K9208EB	500mm electrode Assembly (C=0.05cm ⁻¹) for SC210G-A
K9208EC	1000mm electrode Assembly (C=0.05cm ⁻¹) for SC210G-A
K9208ED	1500mm electrode Assembly (C=0.05cm ⁻¹) for SC210G-A
K9208EE	2000mm electrode Assembly (C=0.05cm ⁻¹) for SC210G-A
K9208EF	300mm electrode Assembly (C=0.05cm ⁻¹) for SC210G-A
K9315NA	150mm electrode Assembly (C=0.05cm ⁻¹) with perfluoro-elastomer, for SC210G-A
K9315NB	500mm electrode Assembly (C=0.05cm ⁻¹) with perfluoro-elastomer, for SC210G-A
K9315NC	1000mm electrode Assembly (C=0.05cm ⁻¹) with perfluoro-elastomer, for SC210G-A
K9315ND	1500mm electrode Assembly (C=0.05cm ⁻¹) with perfluoro-elastomer, for SC210G-A
K9315NE	2000mm electrode Assembly (C=0.05cm ⁻¹) with perfluoro-elastomer, for SC210G-A
K9315NF	300mm electrode Assembly (C=0.05cm ⁻¹) with perfluoro-elastomer, for SC210G-A
K9208KA	Electrode Assembly (C=0.05cm ⁻¹) of gate valve type for SC210G-A
K9315NN	Electrode Assembly (C=0.05cm ⁻¹) of gate valve type with perfluoro-elastomer for SC210G-A
K9208JA	150mm electrode Assembly (C=5cm ⁻¹) for SC210G-B
K9208JB	500mm electrode Assembly (C=5cm ⁻¹) for SC210G-B
K9208JC	1000mm electrode Assembly (C=5cm ⁻¹) for SC210G-B
K9208JD	1500mm electrode Assembly (C=5cm ⁻¹) for SC210G-B
K9208JE	2000mm electrode Assembly (C=5cm ⁻¹) for SC210G-B
K9208JF	300mm electrode Assembly (C=5cm ⁻¹) for SC210G-B
K9315NG	150mm electrode Assembly (C=5cm ⁻¹) with perfluoro-elastomer, for SC210G-B
K9315NH	500mm electrode Assembly (C=5cm ⁻¹) with perfluoro-elastomer, for SC210G-B
K9315NJ	1000mm electrode Assembly (C=5cm ⁻¹) with perfluoro-elastomer, for SC210G-B
K9315NK	1500mm electrode Assembly (C=5cm ⁻¹) with perfluoro-elastomer, for SC210G-B
K9315NL	2000mm electrode Assembly (C=5cm ⁻¹) with perfluoro-elastomer, for SC210G-B
K9315NM	300mm electrode Assembly (C=5cm ⁻¹) with perfluoro-elastomer, for SC210G-B
K9208MA	Electrode Assembly (C=5cm ⁻¹) of gate valve type for SC210G-B
K9315NP	Electrode Assembly (C=5cm ⁻¹) of gate valve type with perfluoro-elastomer for SC210G-B
K9315QA	3m cable for SC210G (M4 ring terminals, SC210G...-03)
K9315QB	5m cable for SC210G (M4 ring terminals, SC210G...-05)
K9315QC	10m cable for SC210G (M4 ring terminals, SC210G...-10)
K9315QF	15m cable for SC210G (M4 ring terminals, SC210G...-15)
K9315QG	20m cable for SC210G (M4 ring terminals, SC210G...-20)
K9315QR	3m cable for SC210G (pin terminals)
K9315QS	5m cable for SC210G (pin terminals)
K9315QT	10m cable for SC210G (pin terminals)
K9315QU	15m cable for SC210G (pin terminals)
K9315QV	20m cable for SC210G (pin terminals)
K9315QJ	3m cable for SC210G (M3 ring terminals)
K9315QK	5m cable for SC210G (M3 ring terminals)
K9315QL	10m cable for SC210G (M3 ring terminals)
K9315QM	15m cable for SC210G (M3 ring terminals)
K9315QQ	20m cable for SC210G (M3 ring terminals)
K9050AT	Viton O-ring (for screw-in type, flange type and flow-through type)
K9050MR	Viton O-ring (for gate valve type)
K9319RN	Perfluoro-elastomer O-ring (for all types)

T06.EPS

DIMENSIONS

1. SC4AJ

Sensor SC4AJ-□-AD-09

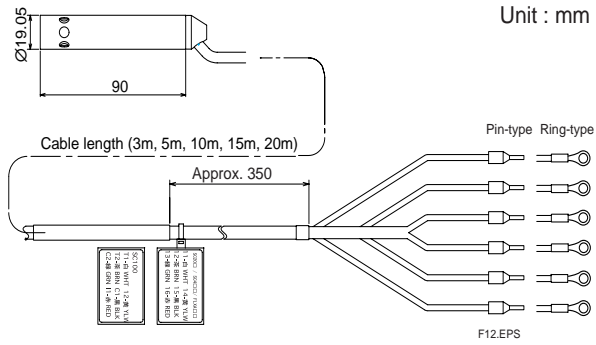

Sensor SC4AJ-□-AD-15

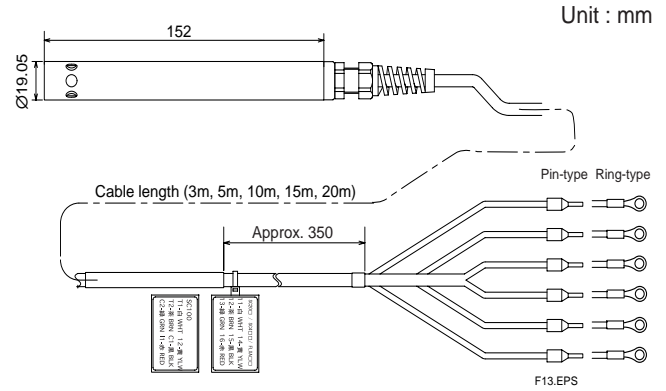

Option for adapter mounting type (-AD)

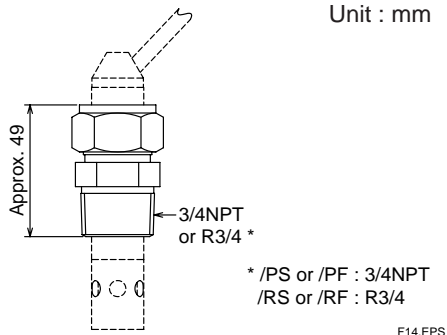

* /PS or /PF : 3/4NPT
/RS or /RF : R3/4

F14.EPS

Sensor SC4AJ-S-SA-NN

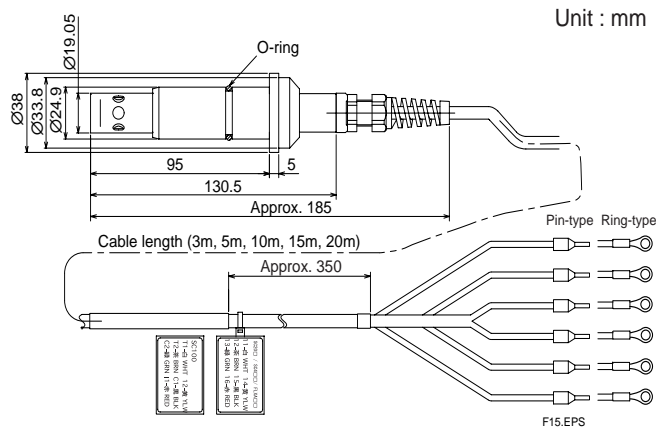

Option for welding socket type (-SA)

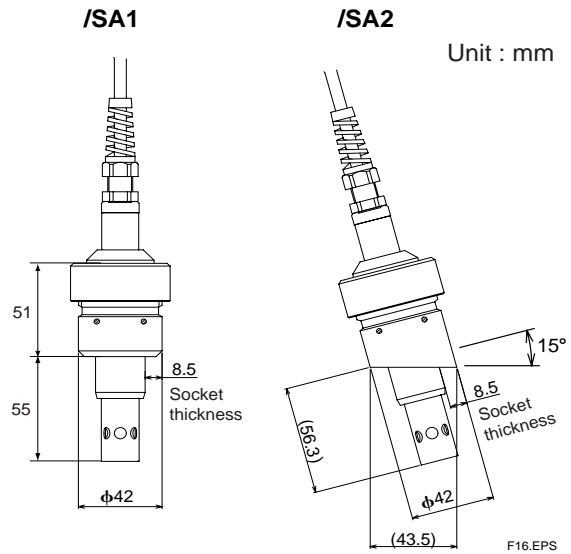

F16.EPS

Sensor SC4AJ-S-SB-NN

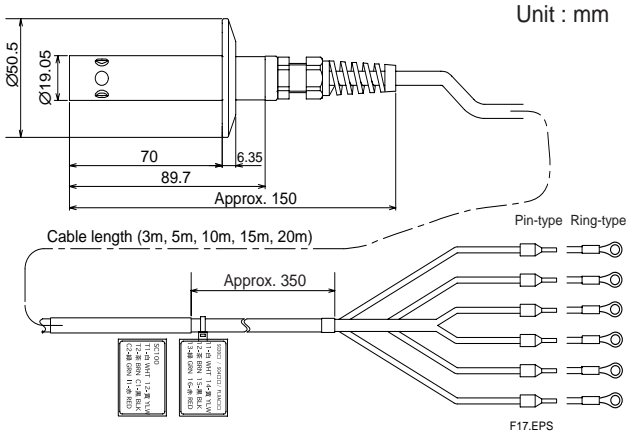

Option for 1 or 1.5 inch welding clamp type (-SB)

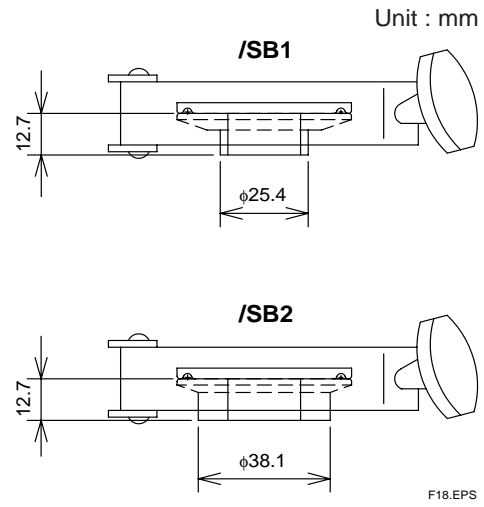

Sensor SC4AJ-S-SC-NN

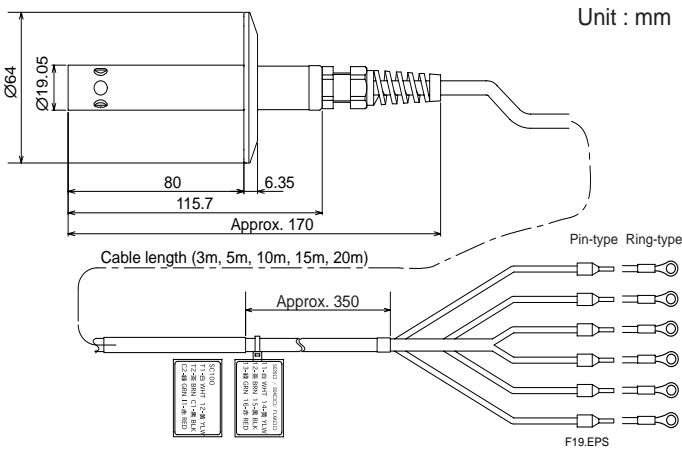

Option for welding clamp type (-SC)

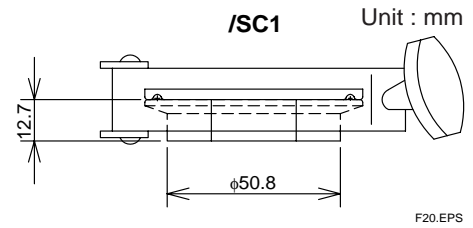

2. SC8SG

Screw-in Model (with welding socket)

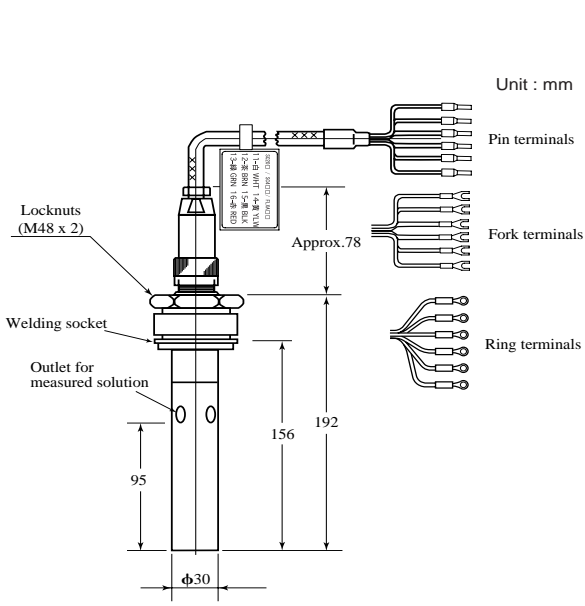

Electrode with 0.01 cm⁻¹ Cell constant
(two-electrode system)

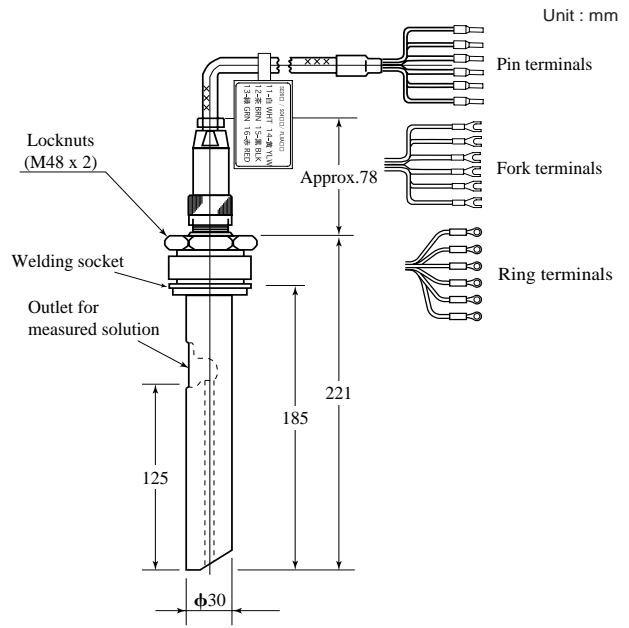

Electrode with 10 cm⁻¹ Cell constant
(two-electrode system)

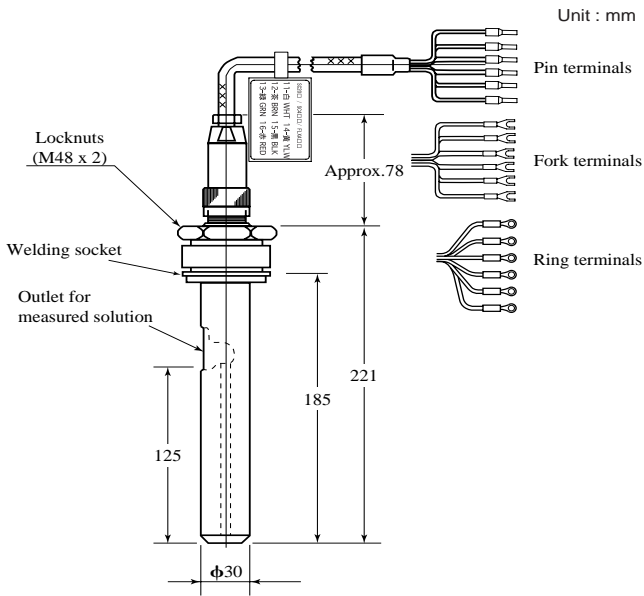

Electrode with 10 cm⁻¹ Cell constant
(Four-electrode system)

Welding socket for Screw-in type (K9208BK)

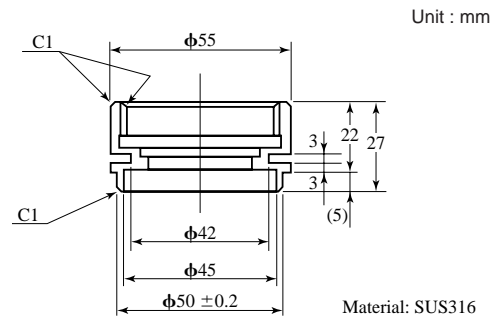

(Note) If you make the welding socket for screw-in type, refer to the above drawing.

Flow-through type (Chamber Material: PP) + Mounting bracket (/PS) --Screw Jointed--

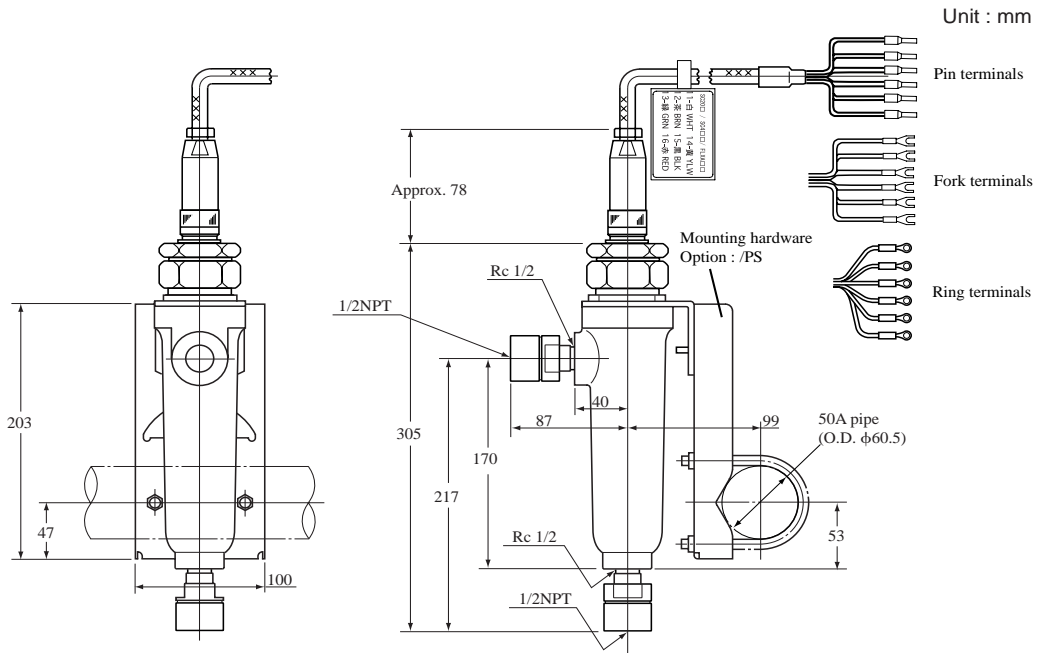

Flow-through type (Chamber Material: PP) + Mounting bracket (/PS) --Flange Jointed--

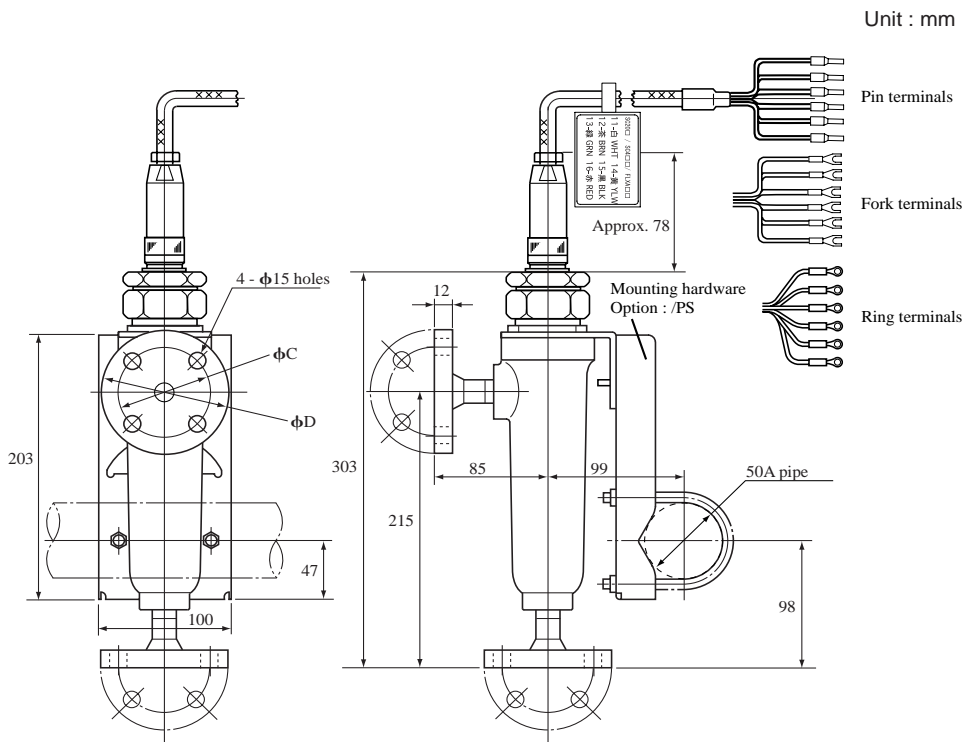

Flange rating	φC	φD
JIS 10K 15 FF	70	95
ANSI Class150 1/2 FF	60.5	88.9

Flow-through type (Chamber Material: SCS14) --Screw Jointed--

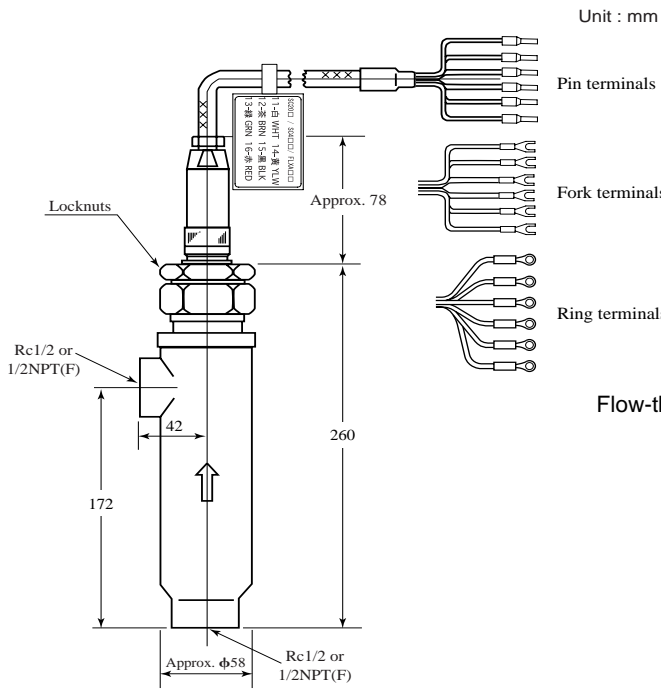

Flow-through type (Chamber Material: SCS14) --Flange Jointed--

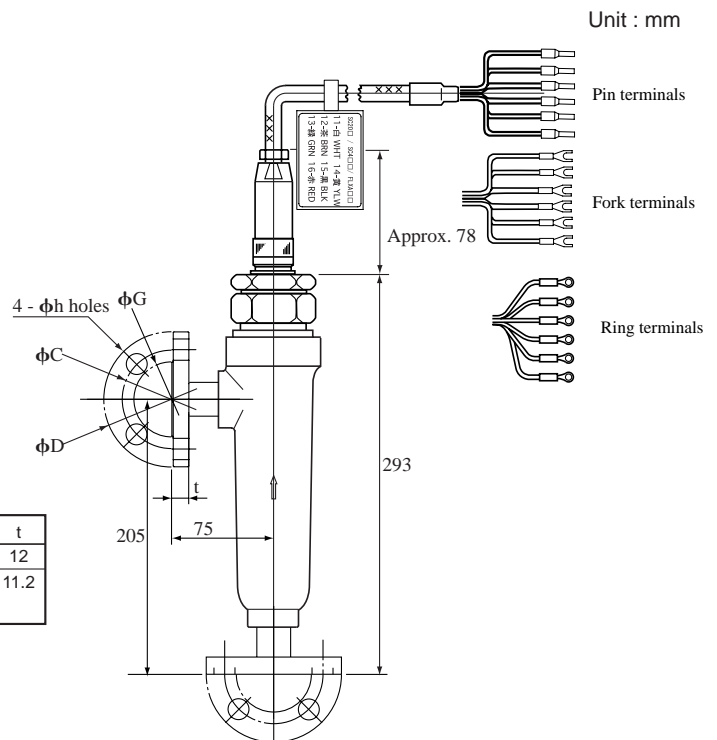

Flange rating	ϕC	ϕD	ϕG	ϕh	t
JIS 10K 15 RF	70	95	52	15	12
ANSI Class150 1/2 RF (with serration)	60.5	88.9	34.9	15.7	11.2

Mounting hardware for flow-through type SCS14 chamber (option: /SS)

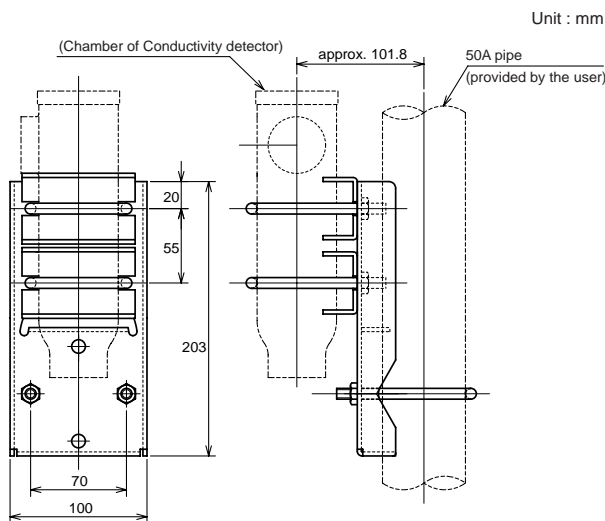

3. WU41 for SC8SG

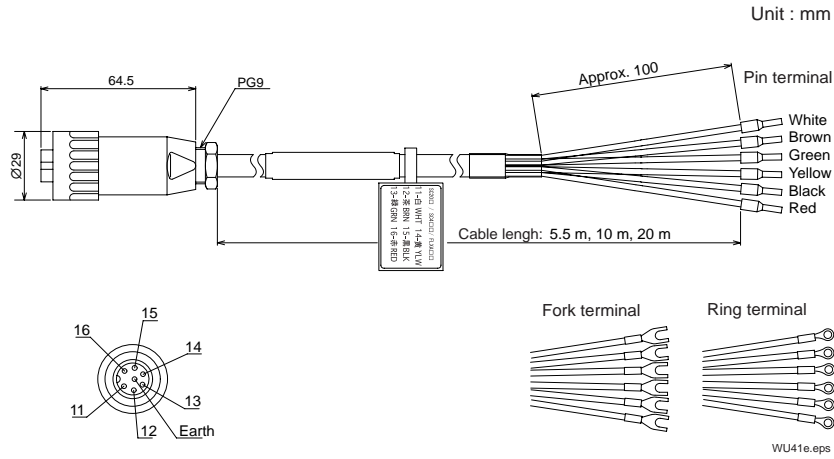

4. SC210G
Screw-in Type

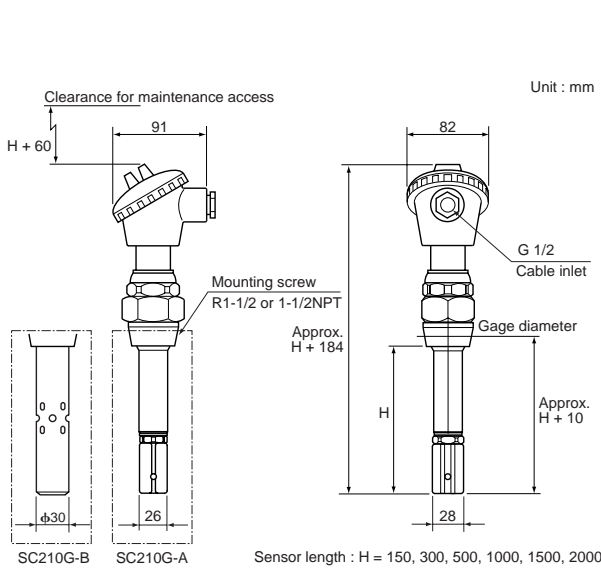

Flange Type

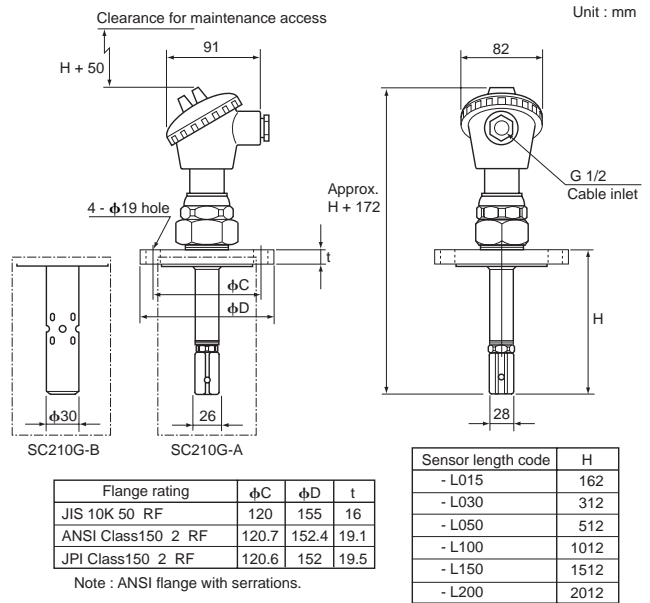

Flow-through Type
(screw connection, Chamber material: SCS14)

Flow-through type + Mounting hardware (/PS)
(screw connection, chamber material: polypropylene)

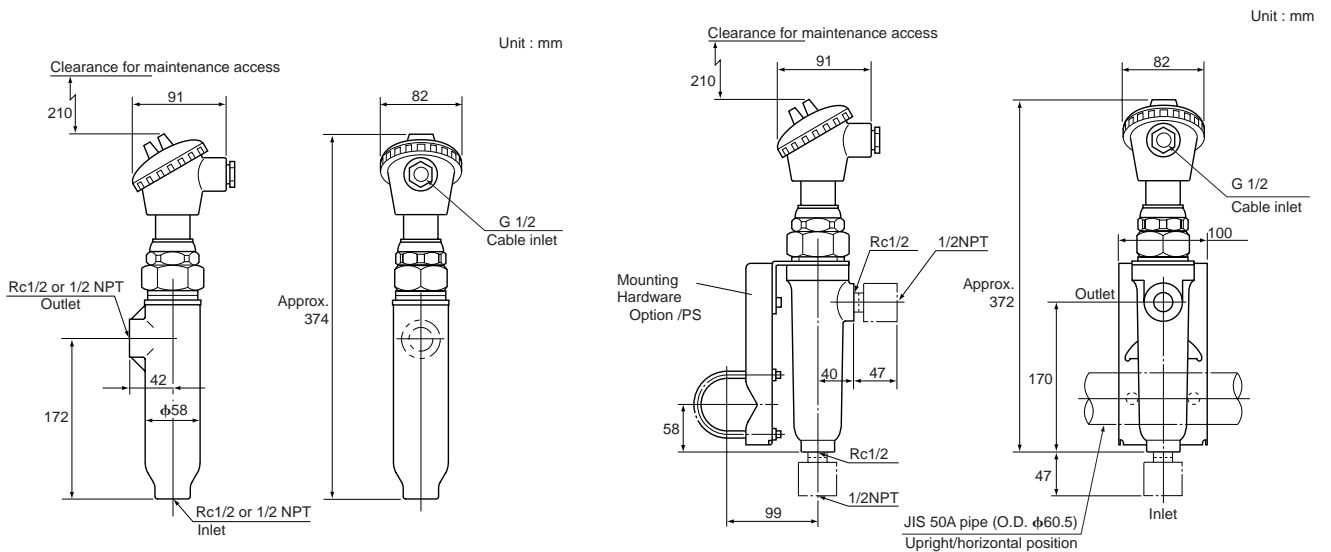

Flow-through type + Mounting hardware (/PS)
(screw connection, chamber material: polypropylene)

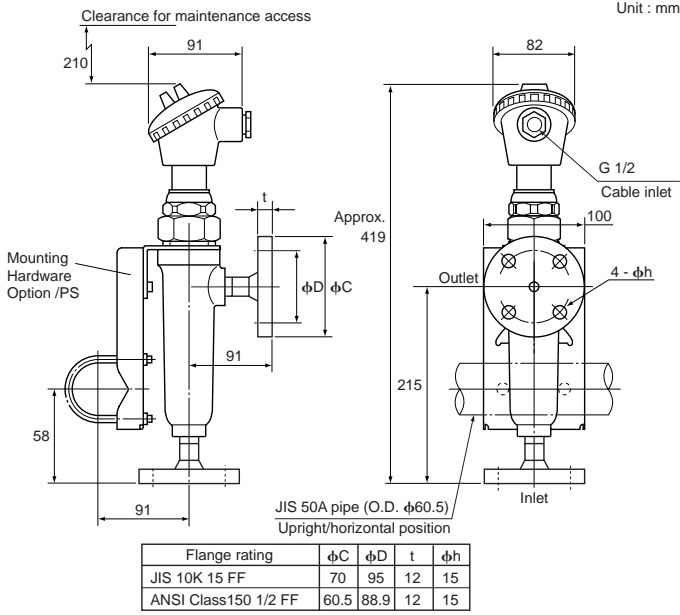

Flow-through type
(screw connection, chamber material: SCS14)

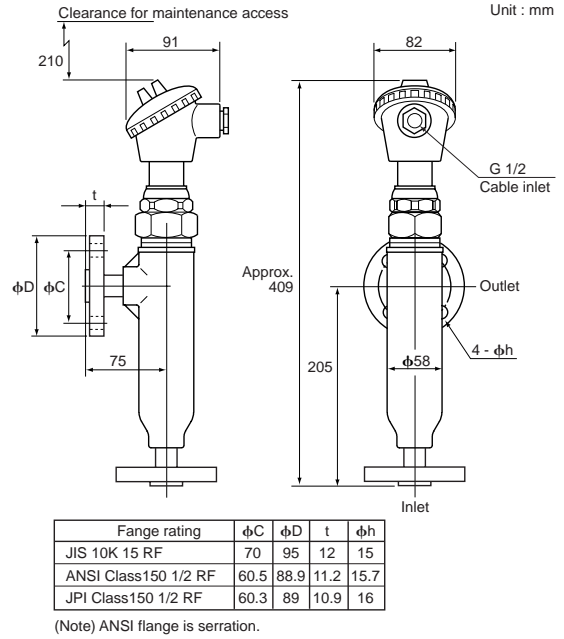

Screw-in type with gate valve
SC210G-A

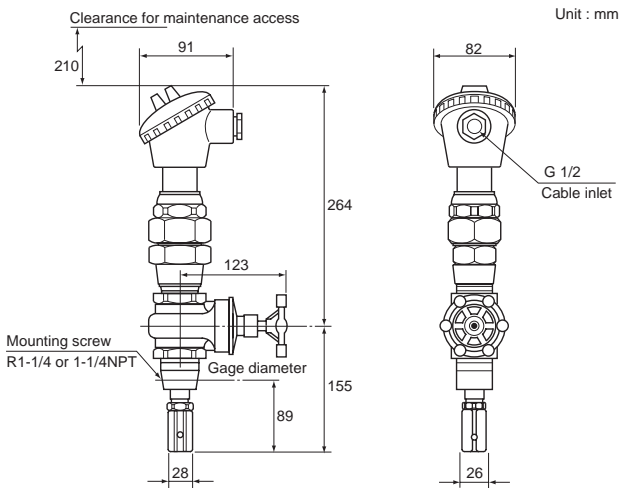

SC210G-B

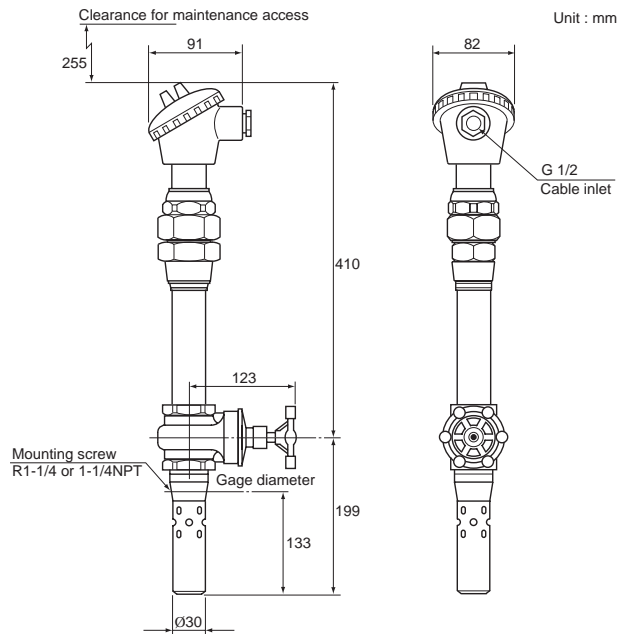

Mounting hardware for flow-through type SCS14 chamber
(option: /SS)

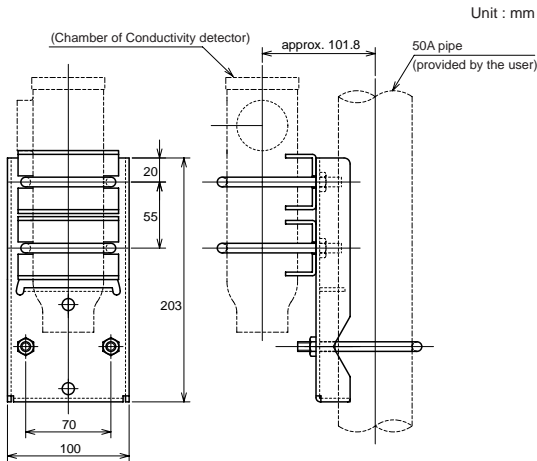

"ANSI" Adaptor of cable inlet

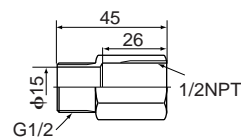

■ WIRING DIAGRAM

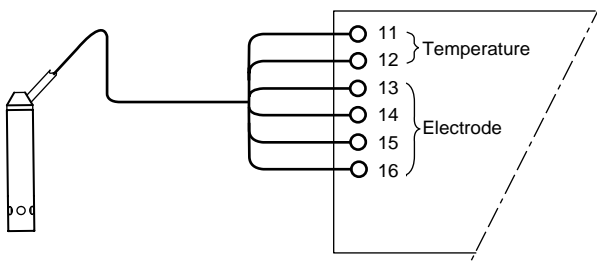

SC4AJ Conductivity Sensor
(two-electrode system)
Applicable Converter / Transmitter:
SC450G, FLXA21, SC202G, SC202SJ
For SC100, see SD12D11A01-01E.

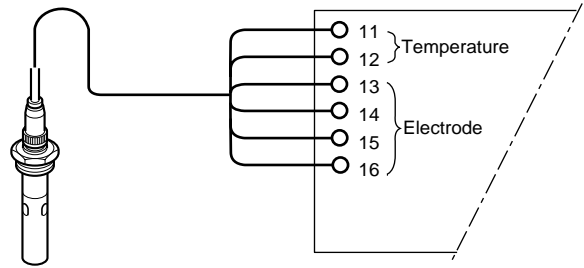

SC8SG Conductivity Detector
(two-electrode system, four-electrode system)
Applicable Converter / Transmitter:
SC450G, FLXA21, SC202G, SC202SJ

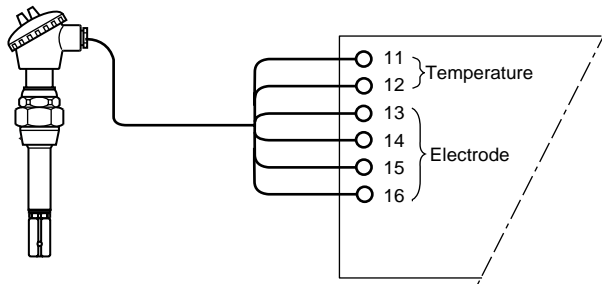

SC210G Conductivity Detector
(two-electrode system)
Applicable Converter / Transmitter:
SC450G, FLXA21, SC202G, SC202SJ

F11.EPS

TABLE OF CORROSION-RESISTANT MATERIALS

Note: This table shows corrosion resistances against each specified chemical only. If two or more kinds of chemical are mixed in a sample, the properties may be different from those shown in this table.

- ◎ Very suitable
- Suitable
- △ Slightly unsuitable
- × Unusable

Example of Description
 Concentration Temperature Judgement
 % °C ◎

		Holder material			Electrode material				Seal O-ring material					
		Polypropylene		SUS316		Epoxy resin		PVDF		Viton				
Inorganic acids	Hydrochloric acid	5	20	◎	5	30	×	5	30	◎	Strong acid ◎ Weak acid ◎			
			80	◎				10	60	×				
	Hypochlorous acid	10	20	◎	14	30	×	15	30	×		20	40	◎
			40	○										
	Nitric acid	10	20	◎	10	30	◎	10	30	◎		10	100	○
		80	◎				25	60	×					
	Sulfuric acid	3	20	◎	5	30	◎	5	20	○	5	30	◎	
		3	100	◎	5	100	×	10	60	×	5	100	×	
	Phosphoric acid	30	60	◎	15	30	◎	5	30	◎	5	30	◎	
		30	100	△	5	b	◎	25	100	×	5	60	○	
Alkali	Ammonia water	15	80	◎	10	b	◎	10	b	◎	10	b	◎	Strong alkali × Weak alkali △
		15	100	○	28	65	◎	28	65	◎	28	65	◎	
	Caustic potash				10	b	◎	10	60	○	10	b	◎	
					25	b	◎	25	b	×	25	b	○	
	Caustic soda	20	80	◎	20	30	◎	20	60	◎	20	30	◎	
		20	100	◎	20	b	◎	20	b	×	20	b	◎	
	Potassium carbonate				5	b	◎	5	b	◎	5	b	◎	
					35	b	◎	35	b	○	35	b	○	
	Sodium carbonate	sat.	100	◎	25	b	◎	25	b	◎	25	b	◎	
Chlorides	Zinc chloride				20	b	△	20	60	○	20	b	◎	
	Aluminum chloride				25	25	×				10	b	◎	
					25	25	×				25	b	×	
	Ammonium chloride	35	40	◎	25	b	△	25	20	○	25	b	◎	
	Potassium chloride				sat.	60	◎	sat.	60	◎	sat.	60	◎	
	Calcium chloride	sat.	80	◎	25	b	○	25	b	◎	25	b	◎	
			sat.	100	◎									
	Ferric chloride	20	40	◎	30	b	×	30	60	○	30	b	◎	
		60	◎				100	×						
	Sodium chloride 20% + C12 (saturated) (Electrolyte)		100	◎		90	×		90	×		90	◎	
	Sea water		24	◎		24	△		60	○		24	◎	
Sulfates	Ammonium sulfate	5	60	◎	20	b	◎	20	b	◎	20	b	◎	
					sat.	30		sat.	30	○	sat.	30	◎	
	Potassium sulfate				10	b	◎	10	b	◎	10	b	◎	
	Sodium sulfate				20	b	◎	20	b	◎	20	b	◎	
Ni-trates	Ammonium nitrate	Good corrosion resistance against all salts normally used			20	b	◎	20	b	◎	20	b	◎	
	Sodium nitrate				50	b	◎	50	b	◎	50	b	◎	
Others	Sodium sulfite				20	b	◎				20	b	◎	
	Hydrogen peroxide				10	30	◎	10	30	◎	10	30	◎	
	Sodium hypochlorite	10	90	◎	2	60 to 90	×	2	60 to 90	×	15	30	◎	
			20	80	◎									
	Potassium bichromate				10	b	◎	10	20	○	10	b	◎	
	Alcohol	96	70	◎	100	b	◎	80	60	○	80	100	○	
	Acetic acid	100	70	◎	100	70	◎	10	60	○	10	100	○	
Phenol	100	20	◎	95	30	◎	100	20	×	100	20	○		
Aromatic solvent	100	20	×	100	25	◎	100	20	×	100		○		

(Note) b: Shows temperatures up to the boiling point. PVDF: Polyvinylidene difluoride

T09.eps

CAUTION



Select the material of wetted parts with careful consideration of process characteristics. Inappropriate selection may cause leakage of process fluids, which greatly affects facilities. Considerable care must be taken particularly in the case of strongly corrosive process fluid such as hydrochloric acid, sulfuric acid, hydrogen sulfide, and sodium hypochlorite. If you have any questions about the wetted part construction of the product, be sure to contact Yokogawa.

