

# General Specifications

## InfraSpec NR800 Fourier Transform Near-Infrared Analyzers

InfraSpec

GS 12Y03A03-01E

### ■ Overview

The InfraSpec NR800 offers high-resolution, high S/N (signal-to-noise) ratio, and wide wavelength scanning range measurement with its newly developed interferometer and detector. The NR800 also offers high stability, vibration resistance, and durability, inheriting features from NR500 earlier successful models. The NR800 allows online, real-time, continuous, multiple, and simultaneous measurement for properties and component concentration of various processes.

### ■ Features (including options)

#### ● Newly developed interferometer and detector

Used for a variety of applications, ranging from over to combination tone.

- High resolution: Up to  $4\text{ cm}^{-1}$ , user selectable setting
- High S/N ratio: 2250:1 (RMS,  $4\text{ cm}^{-1}$  resolution, 4100 to  $4200\text{ cm}^{-1}$ , 1 sec.)
- Wide wavelengths scanning range 900 to 2500 nm ( $11,000$  to  $4000\text{ cm}^{-1}$ )
- Wavelength reproducibility:  $0.007\text{ cm}^{-1}$
- Wavelength accuracy:  $0.04\text{ cm}^{-1}$

#### ● Enhanced environmental resistance, durability, and reliability

- Provides high vibration resistance by a unique design free of sliding parts
- Features a multi-channel measurement optical system free of moving parts
- Eliminates the need for a PC for continuous operation.  
A PC is now only necessary for generating the calibration model and loading data.

#### ● Outstanding wavelength accuracy allows calibration model transport between NR800s

#### ● Outlier detection and self-diagnostic features come as standard function



Explosion proof Model

#### ● Various standard features and available options for optimal system configuration

- Dust-proof and drip-proof: IP53 equivalent or NEMA TYPE 3R
- Optional Explosion-proof Enclosure: FM, CSA, ATEX, NEPSI, TIIS (\*1)
- Line up with CE marking
- Non-moving multi-channel measurement: Expandable to 4 channels
- Up to 12 items can be measured per stream: limited to 64 items / unit
- The optional I/O unit offers a variety of inputs/outputs:  
Analogue output (up to 40 points), analogue input, and contact input/output
- Communication output: RS-422
- Fast Ethernet communication between Engineering PC and the analyzer

(\*1) TIIS: The Technology Institution of Industrial Safety

## 1. Configuration

### 1.1 Configuration examples

- **Modbus output with sampling unit (explosion-proof, 1 measuring channel)**

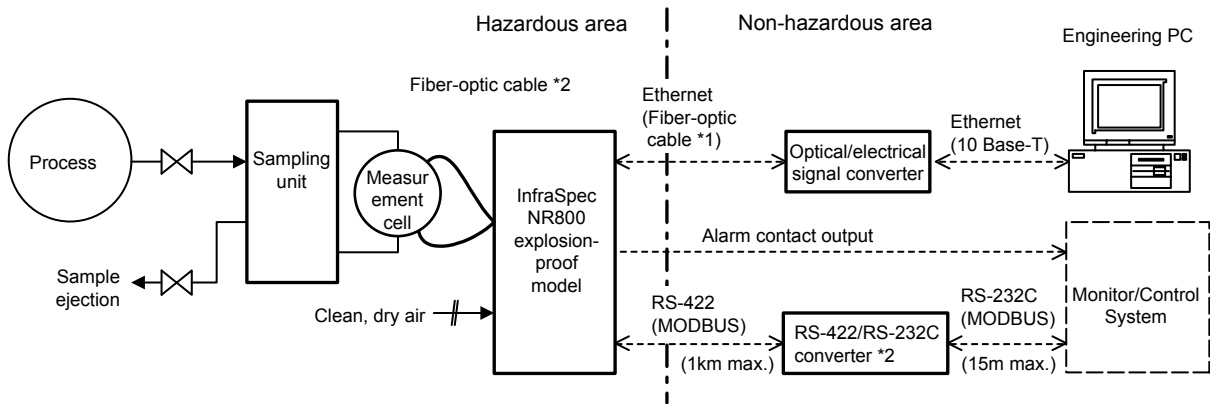

- **Analogue output with sampling unit (explosion-proof, 2 measuring channels)**

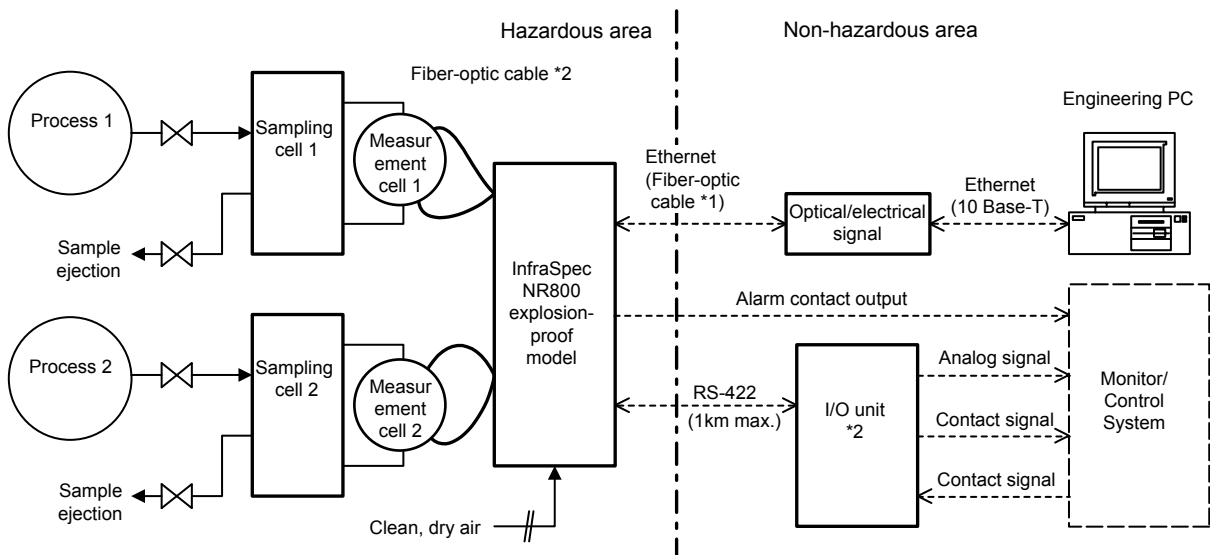

- \*1: Always use a special fiber-optic cable (see section 2.6) for an explosion-proof model, an electric cable cannot be used.  
 For a general purpose model, the type of cable depends on the length.
- Cable length less than 40 m: Either an electric or special fiber-optic cable (see section 2.6 and 6.2) can be used.
  - Cable length of 40 m or longer: Use a special fiber-optic cable (see section 2.6 and 6.2). An electric cable cannot be used.
- \*2: Only use the RS-422 output of an explosion-proof model in combination with an I/O unit (see section 2.2, select Suffix code to Explosion-proof model) or RS-422/RS-232C converter (see section 2.5). These units will block the communication signal upon receiving a Purge failure signal from the Analyzer.  
 And use the dedicated fiber-optic cable for measurement (see section 2.4) and Ethernet communication (see section 2.6). Thus, ensuring the explosion-proof integrity of the analyzer.

## 1.2 Component, software and calibration model generation

Item	Requirement (*1)	Model	Description	Reference	
1	InfraSpec NR800 analyzer	A	NR801AG	General purpose model, CSA standard	1.3 2.1
			NR805AG	Explosion-proof model, FM & NEPSI certified	
			NR805AG /CSA	Explosion-proof model, CSA certified	
			NR801EG	General purpose model with CE marking	
			NR805EG	Explosion-proof model, ATEX & NEPSI certified and CE marking	
			NR801JG	General purpose model, Japanese version	
			NR805JG	Explosion-proof model, TIIS certified	
2	I/O unit	B	NR893AG	To be used with NR801,805AG, CSA standard	1.3 2.1
			NR893EG	To be used with NR801,805EG, and CE marking	
			NR893JG	To be used with NR801,805JG	
3	Measurement cell	A	NR510	Flow through cell	2.3.1
			NR512	Flow through cell with constant temperature water tube	2.3.2
			FIR200	In-situ probe	2.3.3
4	Fiber-optic cable for measurement	A	NR821	Applicable wavelength range: 900 to 2100 nm, Silica, single	2.4.1
			NR822	Applicable wavelength range: 900 to 2100 nm, Silica, dual	
			NR823	Applicable wavelength range: 900 to 2500 nm, Fluoride, single	2.4.2
			NR824	Applicable wavelength range: 900 to 2500 nm, Fluoride, dual	
5	RS-422 / RS-232C converter	B	K9404LA or K9404LD	Converts the RS422 signal from the analyzer into RS-232C.	2.5
6	Ethernet cable (*2)	B	NR895	Dedicated fiber-optic cable (*3)	2.6
			-	Electric cable, provided by user	6.2
7	Software	A	NR831	SpectLand 2 for data management and maintenance	2.7
		B	NR530	Chemometrics software	2.8
8	Sampling unit	B	J439	Yokogawa will propose an optimum unit based on sample pressure, temperature, properties, and measurement items	2.9
9	On-site guidance of calibration model generation	B	J964	Hands-on practice and guidance for model generation on site.	5.1
10	Calibration model generation	B	J965	Calibration model generation by Yokogawa based on user-provided sample with laboratory analysis results	5.2
11	Engineering PC	A	-	Provided by user. See recommended specifications.	6.1
12	Optical / electrical signal converter for Ethernet	B	-	Converts optical signals for an Ethernet output into electrical signals for engineering PC Interface. Provided by user. See recommended specifications	6.2
13	Customer inspection	B	J963	For Instrument except following J443	-
		B	J443	For J439 Sampling unit and FIR200 In-situ probe	-
14	Equipment start-up	B	-	Start-up work for analyzers and sampling units	-

### Notes

\*1: A: Required, B: optional

\*2: An Ethernet cable is required. Choose either a special fiber-optic cable or electric cable depending on the following conditions:  
Always use a special fiber-optic cable (see section 2.6) for an explosion-proof model, an electric cable cannot be used.  
For a general purpose model, the type of cable depends on the length.

- Cable length less than 40 m: Either an electric or special fiber-optic cable (see section 2.6 and 6.2) can be used.

- Cable length of 40 m or longer: Use a special fiber-optic cable (see section 2.6 and 6.2). An electric cable cannot be used.

\*3: For a total cable distance of longer than 20 m, an additional fiber-optic cable (see section 2.6) shall be provided by the user.

### 1.3 Compliant Standards

FT-NIR analyzer	Model		
	NR801AG, NR805AG, NR805AG/CSA	NR801EG, NR805EG	NR801JG, NR805JG
I/O unit	NR893AG	NR893EG	NR893JG
Safety	*1	*2	-
EMC	-	*3	-
CE marking	-	CE marking	-
KC marking	-	*4	-

- \*1: CSA22.2 No.61010-1
  - Installation category (Overvoltage category) II  
Describes a number which defines a transient overvoltage condition. It implies the regulation for impulse withstand voltage.  
"II" applies to electrical equipment which is supplied from fixed installations like distribution boards.
  - Pollution Degree 2  
Describes the degree to a solid, liquid, or gas which deteriorates dielectric strength or surface resistivity is adhering.  
"2" applies to normal indoor atmosphere. Normally, only non-conductive pollution occurs.
- \*2: EN61010-1
  - Installation category (Overvoltage category) II  
Describes a number which defines a transient overvoltage condition. It implies the regulation for impulse withstand voltage.  
"II" applies to electrical equipment which is supplied from fixed installations like distribution boards.
  - Pollution Degree 2  
Describes the degree to a solid, liquid, or gas which deteriorates dielectric strength or surface resistivity is adhering.  
"2" applies to normal indoor atmosphere. Normally, only non-conductive pollution occurs.
- \*3: EMC directive
  - EN61326-1: Class A, Table 2 (For use in industrial location)
  - EN61326-2-3
  - EN61000-3-2
  - EN61000-3-3 +A1 +A2

CAUTION: This instrument is a Class A product, and it is designed for use in the industrial environment. Please use this instrument in the industrial environment only.
- \*4: Korea Electromagnetic Conformity Standard

## 2. Component specifications (including options)

### 2.1 NR800 Fourier Transform Near-Infrared Analyzers

#### 2.1.1 Hardware specifications

Principle: Fourier-transform remote measurement via fiber-optic cable  
 Measurement method: Optical transmission absorption  
 Measured sample: Liquid  
 Beam source: Halogen lamp (recommended replacement interval for continuous operation: 5000 hours)  
 Detector: InGaAs (indium gallium arsenide) photodiode, effective wavelength range: 900 to 2500 nm  
 Number of measuring channels: 1 to 4 (non-moving)  
 Housing structures: Field suitable with full hinged front cover  
 Fiber-optic cable entry: Cable gland  
 Fiber-optic cable connectors:  
 For measurement; FC  
 For Ethernet; ST  
 Display: LED  
 Keyboard: Covered with water-proof sheeting  
 Operating location requirements: See chapter 4.  
 Grounding type: Independent, 100Ω or lower  
 Insulation resistance: 10 MΩ or greater (500VDC)

Withstanding voltage:

Power Supply	Withstanding Voltage
100VAC, 115VAC	1000 VAC for 1 min.
200VAC, 230VAC	1500 VAC for 1 min.

Coating: Epoxy resin coating

Paint color:

Model	NR801AG, NR801EG, NR801JG	NR805AG, NR805AG/CSA, NR805EG, NR805JG
Flame proof enclosure	-	Lamp black (equivalent to Munsell 0.8Y 2.5/0.4)
Air regulator cover	-	Munsell 0.8Y 2.5/0.4)
Case	Frosty white ( equivalent to Munsell 2.5Y8.4/1.2)	
Display panel	Lamp black (equivalent to Munsell 0.8Y 2.5/0.4)	
Wall mount bracket, Free standing rack	Deep sea moss green (equivalent to Munsell 0.6GY3.1/2.0)	

Model		NR801AG	NR801EG	NR801JG	NR805AG	NR805AG/CSA	NR805EG	NR805JG
Explosion proof		General purpose type (non explosion-proof)			FM *1 NEPSI *2	CSA *3	ATEX *4 NEPSI *2	TIIS *5
CE marking		-*6	A *6 *7	-	-*6	-*6	A *6 *7	-
Housing structure		IP53, NEMA 3R or CSA Type 3R						
Air (purge gas) connection		-			1/4NPT (F)		Rc1/4 or 1/4NPT (F)	Rc1/4 or 1/4NPT (F)
Cable connection		Packing gland			3/4NPT(F)		G3/4(F), 3/4NPT(F), M25x1.5(F), or PG21(F)	Frame-proof packing gland or sealing fitting
Weight (kg) *8	Without bracket	Approx. 50			Approx. 65			
	With wall mount bracket	Approx. 55			Approx. 70			
	Free stand rack	Approx. 85			Approx. 100			

- \*1: Type X purging and explosion proof for Class I, Division 1, Groups B, C and D. Temperature Class T5.  
All wiring shall comply with the manufacture's instructions, National Electrical Code ANSI/NFPA 70 and Local Electrical Codes.
- \*2: Ex pxd II B+H2 T5  
All wiring shall comply with the manufacture's instructions and Local Electrical Codes.
- \*3: Type X purging and explosion proof for Class I, Division 1, Groups B, C and D. Temperature Class T5.  
All wiring shall comply with the manufacture's instructions, Canadian Electrical Code Part I and Local Electrical Codes.
- \*4: KEMA 02ATEX2175, II 2G, EEx pd II B+H2 T5  
All wiring shall comply with the manufacture's instructions and Local Electrical Codes.
- \*5: Ex pd II B+H2 T5 X  
All wiring shall comply with the manufacture's instructions and Local Electrical Codes.
- \*6: Use a 5 A breaker in the power supply circuit.
- \*7: A: applicable
- \*8: Not including weight of the packaging materials.

**2.1.2 Performance**

Wavelength scanning range: 900 to 2500 nm  
(11000 to 4000 cm<sup>-1</sup>)  
Wavelength resolution: 4, 8, 16, 32, and 64 cm<sup>-1</sup>  
(user selectable)  
Wavelength reproducibility: 0.007 cm<sup>-1</sup>  
Wavelength accuracy: 0.04 cm<sup>-1</sup>  
S/N ratio 2250:1 (RMS, resolution 4 cm<sup>-1</sup>, 11000 to 4000 cm<sup>-1</sup>, 1 sec.)

**2.1.3 Inputs/Outputs (see also section 2.2 I/O Unit)**

**(1) Communication Interface:**

Engineering PC: 1 channel (Ethernet)  
DCS / I/O unit: 2 channels (RS-422)  
1 channel for DCS (Modbus) and  
another for I/O unit; or 2 channels for I/O  
unit

**(2) Contact outputs:**

Specification: NC/NO selectable, 2 channels  
Rating: 0.5 A, 30 VDC or less  
Action:  
General purpose model:

**NR800 converter power "ON/OFF"; Power fail signal**

Status	Terminal Number	
	1 to 2	2 to 3
Power "off"	Short	Open
Power "on"	Open	Short

**NR800 System alarm**

Status	Terminal Number	
	1 to 2	2 to 3
Power "off"	Short	Open
Alarm occurred	Short	Open
Alarm not occurred	Open	Short

Explosion proof model:

**NR800 System alarm**

Status	Terminal Number	
	D1 to D2	D2 to D3
Power "off"	Open	Short
Alarm occurred	Open	Short
Alarm not occurred	Short	Open

**Annunciator signal output**

Status	Terminal Number	
	A1 to A2	A2 to A3
Power "off"	Open	Short
During purging	Open	Short
Override switch pressed *	Open	Short
After purging	Short	Open

\*: Overriding  
 When opening the door of the pressurized explosion-protected enclosure under power on, the inner-pressure protection system will automatically turn off the power. The function that disables this automatic power off is called "overriding."  
 The override switch is located inside the analyzer (flameproof). You can use overriding to open the door of the explosion-protected section.  
 When opening the door, always makes sure the ambient atmosphere is non-hazardous using, for example, a gas sensor.

**2.1.4 Operating modes \*1**

Basic operating mode and description		Channel operating mode	
		No.	Auto/Manual.*3
Maintenance *2	Spectrum analysis of a reference sample, equipment maintenance	-	-
Run	On-line measurement (allows spectrum analysis on selected channels)	1	AUTO
			MANUAL
		2	AUTO
			MANUAL
		3	AUTO
			MANUAL
		4	AUTO
			MANUAL

Notes  
 \*1: When the power is turned on, the analyzer starts according to a predefined operating mode.  
 \*2: Can perform spectrum analysis (not continuous measurement).  
 \*3: Auto: Performs continuous measurement  
 Manual: Can perform spectrum analysis (not continuous measurement).

**2.1.5 Changing and Setting Operating Mode**

Some operations are prohibited depending on the user level.

User level	Abbreviation	Description	Changing/setting mode
User B	UB	For equipment supervisor	Authorized
User C	UC	For maintenance	Authorized

- A user level can be switched on the front console panel of the analyzer or from SpectLand 2 screen of an engineering PC.
- A password is required to switch levels from UA to UB and switch from UA or UB to UC.

**2.1.6 Sample Measurement**

**(1) Continuous measurement**

Number of measuring channels:  
 1 to 4 (Specification is required.)  
 Data updating period:  
 4 seconds or longer (depending on the number of averaging and measuring channels, as well as measurement items)  
 Number of measurement items:  
 Up to 12 per channel (48 max. per analyzer)  
 Number of outlier detection items:  
 Up to 12 per channel (48 max. per analyzer)  
 Separate maintenance is available for each channel (except for common hardware).

**(2) Stream switching by input signal (intermittent measurement)**

Calibration model set for the each channel can be changed by external input signal. This function is used for multi-stream application or multi sample application.  
 Stream switching  
 Number of streams to switch: Up to 16  
 Switching patterns:  
 See table 1. "Stream numbers assignable to measuring channels corresponding to switching patterns"  
 Contact inputs:  
 See section "2.2 I/O Unit"  
 RS-422 communication:  
 See section "2.1.8 MODBUS"  
 Data updating period:  
 8 seconds or longer (depending on the switching pattern, numbers of averaging and measuring channels, and stream configuration)  
 Number of measurement items:  
 Up to 12 per stream (64 max. per analyzer)  
 Number of outlier detection items:  
 Up to 12 per stream (64 max. per analyzer)  
 Separate maintenance is available for each channel (except for common hardware).

Input signals and measurement computation sequence

Stream identification:

Used to identify the selected sample.  
The analyzer will choose a calibration model set to suite for the relevant stream based on this signal.

Measurement enabled (valid sample):

When closed, the analyzer performs measurement using the calibration model specified by the sample identification signal above.

Schematic timing chart of measurement and computation sequence (e.g. 2 streams)

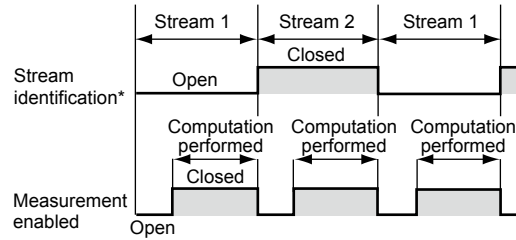

Notes

(\*) A stream number is defined by a combination of open/closed states of an identification contact signal.

Table 1 Stream numbers assignable to measuring channels corresponding to switching patterns

Stream switch		Measuring channel No. *3				Total streams	Applicable channel No.
Case	Pattern No.	1	2	3	4		
None	0	1	2	3	4	4 max	1 to 4
Stream switching per channel *2	1 *1	1 to (17-N)	18-N	19-N	20-N	16 max	1 to 4
	2	1 to 8	9 to 16	None	None	16 max	1 to 2
	3	1 to 4	5 to 8	9 to 12	13 to 16	16 max	1 to 4

Notes

\*1: N: Maximum number of measuring channels included within the analyzer.

\*2: The stream number for a measuring channel that does not switch paths must be the smallest number in the relevant column.

\*3: Measuring channel numbers that equal the number of measuring channels included within the analyzer or smaller are valid.

2.1.7 Console Panel

(1) Display items

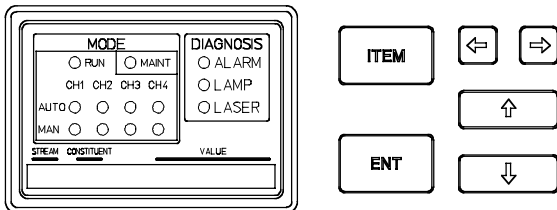

Operating mode LEDs (MODE)

The following LEDs indicate the current basic operating mode:

- RUN:** Lit when in the Run mode.
- MAINT:** Lit when in the Maintenance mode. The operating modes of each channel are displayed by LEDs when in the Run mode. Two LEDs are provided for each channel, amounting to a total of 8 LEDs.
- AUTO:** Lit when in the Auto mode.
- MAN:** Lit when in the Manual mode.

Self-diagnosis LEDs (DIAGNOSIS)

- ALARM:** Lit when an alarm occurs.
- LAMP:** Lit when a lamp has burned out or after a time period defined by the service life setting elapses.

**LASER:** Lit when the laser has burned out or after a time period defined by the service life setting elapses.

**LED display (16 digits, STREAM/CONSTITUENT/VALUE)**  
The content depends on the operating status or operation.

Operation keys

The following six keys are provided:

- ITEM:** Used to change items.
- ENT:** Used to confirm the entry.
- Arrow keys:** Used to move the cursor or change display.

(2) Analyzer behavior for each basic operating mode

Maintenance mode

- Basic operating mode LEDs:** Only MAINT lights up.
- Channel operating mode LEDs:** Lit in accordance with each setting.
- Self-diagnosis LEDs:** Lit in accordance with the results of self-diagnosis.
- LED display:** The display depends on the operating status.

Run mode

Basic operating mode LEDs:

Only RUN lights up.

Channel operating mode LEDs:

Lit in accordance with each setting.

Self-diagnosis LEDs:

Lit in accordance with the results of self-diagnosis.

LED display:

The display depends on the operating status.

**2.1.8 MODBUS**

**(1) Communication specifications**

Item	Specification
Communication standard*	RS-422 or RS-232C (a converter is required)
Start bit	1
Number of data bits	7 (ASCII mode) or 8 (binary mode)
Parity bit	1
Stop bit	1
Communication speed	4800, 9600 or 19200 (selectable)
Error detection	Odd number parity, Even number Parity or none (selectable)

\*: Only RS-232C can be used in NR805\*G explosion-proof type.  
See section 1.2 and 2.5

**(2) Serial communication**

Item	ASCII mode	RTU mode
Number of data bits	7 (ASCII)	8 (binary)
Message starting character	Colon “.”	None
Message ending character	Carriage return/Line feed “<CR><LF>”	None
Error detection	LRC (Logical Redundancy Check)	CRC-16 (Cyclic Redundancy Check)
Inter-character time out	None	100msec

**(3) Support function in the MODBUS protocol**

Function No.	Description
01	Reads the ON/OFF status of coils.
02	Reads the ON/OFF status of input relays.
03	Reads the current value of holding registers.
04	Reads the current value of input registers.
05	Forcibly changes the status of a coil.
06	Write a value to a holding register.
08	Loop-back test Sends back the same message as the command message.

**(4) Recommended value of master side**

Item	Recommended value
Transmission speed (bps)	4800/9600/19200
Time monitor of Inter-character gap	1000ms
No reply time	2 sec.
Number of transmission retries	5 times
Communication Recovery Period	30 sec.

**2.1.9 Other Functions**

**(1) Baseline compensation: Up to 10 points**

**(2) Output of the result compensated using analogue inputs**

The following operation result can be output.  
Compensation operation processing:

$$P2 = C1 * P1 + C0 + D$$

$$D = An^2 * D2 + An * D1 + D0$$

An: Analogue input (n: 4 or less)

P1: Measurement value before the compensation

P2: Measurement value after the compensation

D0, D1, D2, C0, C1: Coefficient

**(3) Output smoothing**

Simple moving average (Up to 10 points)

Exponential moving average

**(4) On-line measurement spectra saving**

2.1.10 Model and Suffix Codes

(1) NR801AG, General purpose model

Model	Suffix Code	Option Code	Description
<b>NR801AG</b>	.....	.....	NR800 FT-NIR Analyzer, General Purpose model
Language	-E	.....	English
Power supply	1	.....	100 V AC ±10%, 50/60 Hz
	3	.....	115 V AC ±10%, 50/60 Hz
	4	.....	200 V AC ±10%, 50/60 Hz
	6	.....	230 V AC ±10%, 50/60 Hz
-	-N	.....	Always "-N"
-	-N	.....	Always "-N"
Number of measuring channels	-S1	.....	1 channel
	-M1	.....	Expandable to 4 channels, comes with 1 channel
	-M2	.....	Expandable to 4 channels, comes with 2 channels
	-M3	.....	Expandable to 4 channels, comes with 3 channels
	-M4	.....	4 channels
Wavelength scanning range	W1	.....	900 to 2100 nm
	W2	.....	900 to 2500 nm
Fiber-optic cable	-1	.....	Single cable
	-2	.....	Dual cable
-	-00	.....	Always "-00"
Ethernet output cable	1	.....	Electric cable, only for general purpose model and less than 40 m
	2	.....	Fiber-optic cable
Mounting	A	.....	Without brackets
	B	.....	With wall-mounting brackets
	C	.....	With free standing rack
-	-N	.....	Always "-N"
-	-N	.....	Always "-N"
-	-0	.....	Always "-0"
-	0	.....	Always "0"
Option		/SS	With stream switch input function

**(2) NR805AG, Type X purged and FM approved, CSA approved or NEPSI approved explosion-proof model**

Model	Suffix Code	Option Code	Description
<b>NR805AG</b>	.....	.....	NR800 FT-NIR Analyzer, Explosion proof model, FM/NEPSI approved version (*1)
Language	-E	.....	English
Power supply	1	.....	100 V AC ±10%, 50/60 Hz
	3	.....	115 V AC ±10%, 50/60 Hz
	4	.....	200 V AC ±10%, 50/60 Hz
	6	.....	230 V AC ±10%, 50/60 Hz
-	-N	.....	Always "-N"
-	-N	.....	Always "-N"
Number of measuring channels	-S1	.....	1 channel
	-M1	.....	Expandable to 4 channels, comes with 1 channel
	-M2	.....	Expandable to 4 channels, comes with 2 channels
	-M3	.....	Expandable to 4 channels, comes with 3 channels
	-M4	.....	4 channels
Wavelength scanning range	W1	.....	900 to 2100 nm
	W2	.....	900 to 2500 nm
Fiber-optic cable	-1	.....	Single cable
	-2	.....	Dual cable
-	-00	.....	Always "-00"
Ethernet output cable	2	.....	Fiber-optic cable
Mounting	A	.....	Without brackets
	B	.....	With wall-mounting brackets
	C	.....	With free standing rack
-	-N	.....	Always "-N"
-	-N	.....	Always "-N"
Cable entrance	-2	.....	Female 3/4NPT
Purge air connection	2	.....	Female 1/4NPT
Option	/SS	.....	With stream switch input function
	/CSA	.....	CSA approved version (*1)

(\*1) Option code "/CSA" is specified CSA approved  
 Option code "/CSA" is not specified FM/NEPSI approved

(3) NR801EG, General purpose model, with CE marking

Model	Suffix Code	Option Code	Description
NR801EG	.....	.....	NR800 FT-NIR Analyzer, General Purpose model, CE marking
Language	-E	.....	English
Power supply	1	.....	100 V AC ±10%, 50/60 Hz
	3	.....	115 V AC ±10%, 50/60 Hz
	4	.....	200 V AC ±10%, 50/60 Hz
	6	.....	230 V AC ±10%, 50/60 Hz
-	-N	.....	Always "-N"
-	-N	.....	Always "-N"
Number of measuring channels	-S1	.....	1 channel
	-M1	.....	Expandable to 4 channels, comes with 1 channel
	-M2	.....	Expandable to 4 channels, comes with 2 channels
	-M3	.....	Expandable to 4 channels, comes with 3 channels
	-M4	.....	4 channels
Wavelength scanning range	W1	.....	900 to 2100 nm
	W2	.....	900 to 2500 nm
Fiber-optic cable	-1	.....	Single cable
	-2	.....	Dual cable
-	-00	.....	Always "-00"
Ethernet output cable	1	.....	Electric cable, only for general purpose model and less than 40 m
	2	.....	Fiber-optic cable
Mounting	A	.....	Without brackets
	B	.....	With wall-mounting brackets
	C	.....	With free standing rack
-	-N	.....	Always "-N"
-	-N	.....	Always "-N"
-	-0	.....	Always "-0"
-	0	.....	Always "0"
Option		/SS	With stream switch input function

**(4) NR805EG, ATEX or NEPSI approved explosion-proof model, with CE marking**

Model	Suffix Code	Option Code	Description
<b>NR805EG</b>	.....	.....	NR800 FT-NIR Analyzer, Explosion-proof model, ATEX / NEPSI approved, CE marking
Language	-E	.....	English
Power supply	1	.....	100 V AC ±10%, 50/60 Hz
	3	.....	115 V AC ±10%, 50/60 Hz
	4	.....	200 V AC ±10%, 50/60 Hz
	6	.....	230 V AC ±10%, 50/60 Hz
-	-N	.....	Always "-N"
-	-N	.....	Always "-N"
Number of measuring channels	-S1	.....	1 channel
	-M1	.....	Expandable to 4 channels, comes with 1 channel
	-M2	.....	Expandable to 4 channels, comes with 2 channels
	-M3 -M4	.....	Expandable to 4 channels, comes with 3 channels 4 channels
Wavelength scanning range	W1	.....	900 to 2100 nm
	W2	.....	900 to 2500 nm
Fiber-optic cable	-1	.....	Single cable
	-2	.....	Dual cable
-	-00	.....	Always "-00"
Ethernet output cable	2	.....	Fiber-optic cable
Mounting	A	.....	Without brackets
	B	.....	With wall-mounting brackets
	C	.....	With free standing rack
-	-N	.....	Always "-N"
-	-N	.....	Always "-N"
Cable entrance	-3	.....	Female G3/4
	-4	.....	Female 3/4NPT
	-5	.....	Female M25x1.5
	-6	.....	Female PG21
Purge air connection	1	.....	Female Rc1/4
	2	.....	Female 1/4 NPT
Option		/SS	With stream switch input function

(5) NR801JG, General purpose model

Model	Suffix Code	Option Code	Description
<b>NR801JG</b>	.....	.....	NR800 FT-NIR Analyzer, General Purpose model
Language	-E -J	..... .....	English Japanese
Power supply	1 3 4 6	..... ..... ..... .....	100 V AC ±10%, 50/60 Hz 115 V AC ±10%, 50/60 Hz 200 V AC ±10%, 50/60 Hz 230 V AC ±10%, 50/60 Hz
-	-N	.....	Always "-N"
-	-N	.....	Always "-N"
Number of measuring channels	-S1 -M1 -M2 -M3 -M4	..... ..... ..... ..... .....	1 channel Expandable to 4 channels, comes with 1 channel Expandable to 4 channels, comes with 2 channels Expandable to 4 channels, comes with 3 channels 4 channels
Wavelength scanning range	W1 W2	..... .....	900 to 2100 nm 900 to 2500 nm
Fiber-optic cable	-1 -2	..... .....	Single cable Dual cable
-	-00	.....	Always "-00"
Ethernet output cable	1 2	..... .....	Electric cable, only for general purpose model and less than 40 m Fiber-optic cable
Mounting	A B C	..... ..... .....	Without brackets With wall-mounting brackets With free standing rack
-	-N	.....	Always "-N"
-	-N	.....	Always "-N"
-	-0	.....	Always "-0"
-	0	.....	Always "0"
Option		/SS	With stream switch input function

(6) NR805JG, TIIS approved explosion-proof model

Model	Suffix Code	Option Code	Description
NR805JG	.....	.....	NR800 FT-NIR Analyzer, Explosion-proof model, TIIS approved
Language	-E -J	..... .....	English Japanese
Power supply	1 3 4 6	..... ..... ..... .....	100 V AC ±10%, 50/60 Hz 115 V AC ±10%, 50/60 Hz 200 V AC ±10%, 50/60 Hz 230 V AC ±10%, 50/60 Hz
-	-N	.....	Always "-N"
-	-N	.....	Always "-N"
Number of measuring channels	-S1 -M1 -M2 -M3 -M4	..... ..... ..... ..... .....	1 channel Expandable to 4 channels, comes with 1 channel Expandable to 4 channels, comes with 2 channels Expandable to 4 channels, comes with 3 channels 4 channels
Wavelength scanning range	W1 W2	..... .....	900 to 2100 nm 900 to 2500 nm
Fiber-optic cable	-1 -2	..... .....	Single cable Dual cable
-	-00	.....	Always "-00"
Ethernet output cable	2	.....	Fiber-optic cable
Mounting	A B C	..... ..... .....	Without brackets With wall-mounting brackets With free standing rack
-	-N	.....	Always "-N"
-	-N	.....	Always "-N"
Cable entrance	-1 -2 -3 -4	..... ..... ..... .....	Metal conduit (G3/4) Metal conduit (3/4NPT) Flameproof packing (G3/4) Flameproof packing (3/4NPT)
Purge air connection	1 2	..... .....	Female Rc1/4 Female 1/4 NPT
Option		/SS	With stream switch input function

2.1.11 External dimensions

(1) General purpose model (NR801\*G type)

- Without brackets (Suffix code: A)

Unit: mm

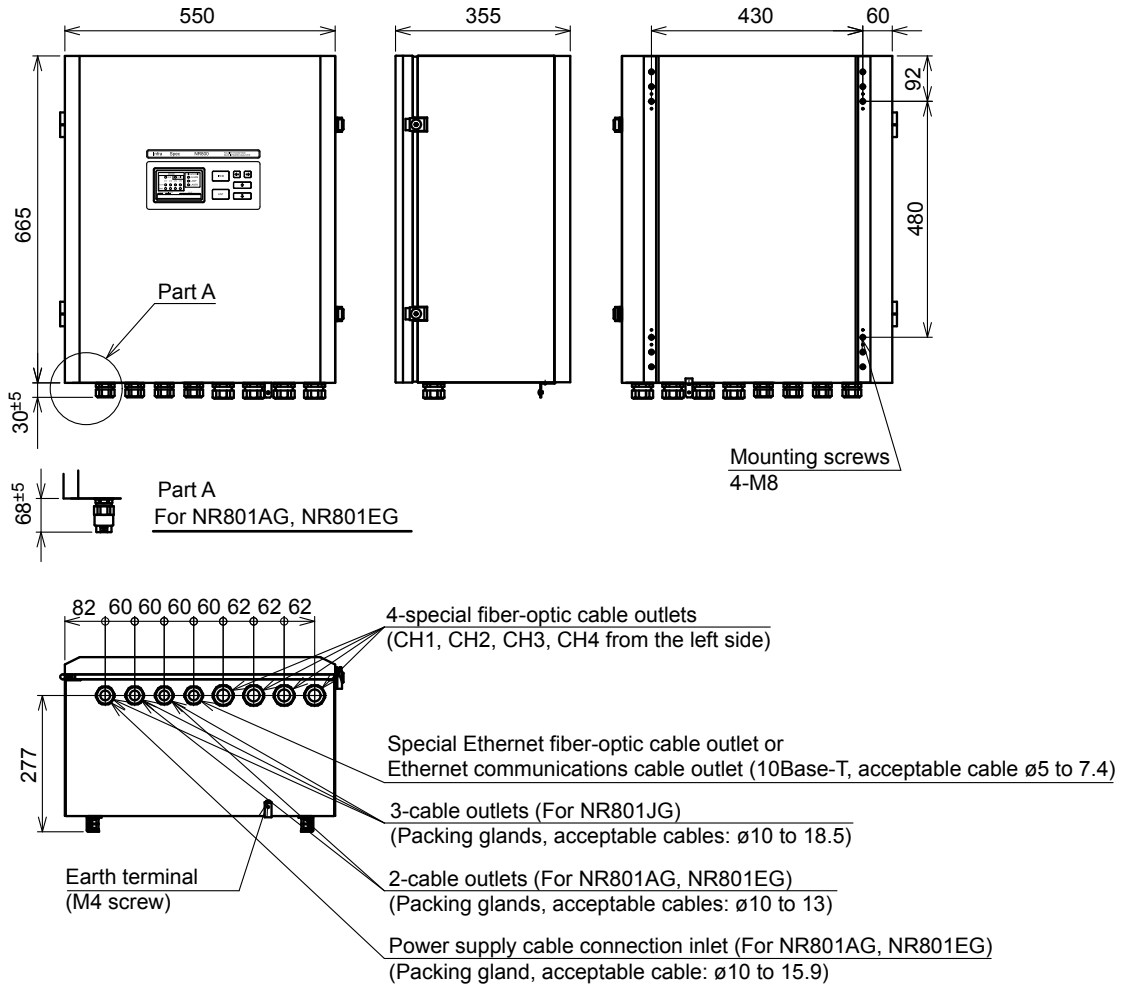

• Wall-mounting model (Suffix code: B)

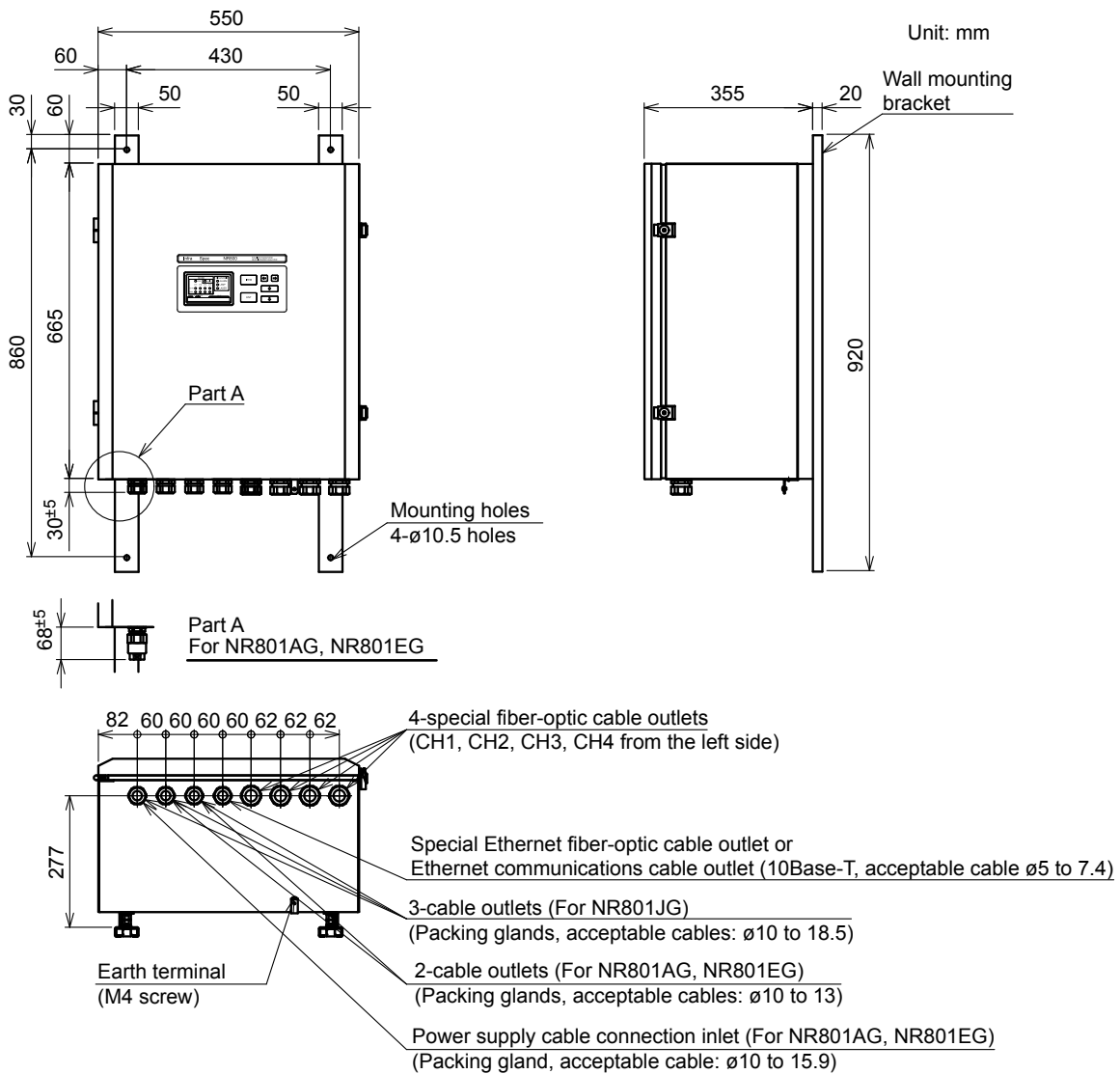

Note: The wall construction should be withstood a force of four times the weight of the NR800.

• Free standing rack model (Suffix code: C)

Unit: mm

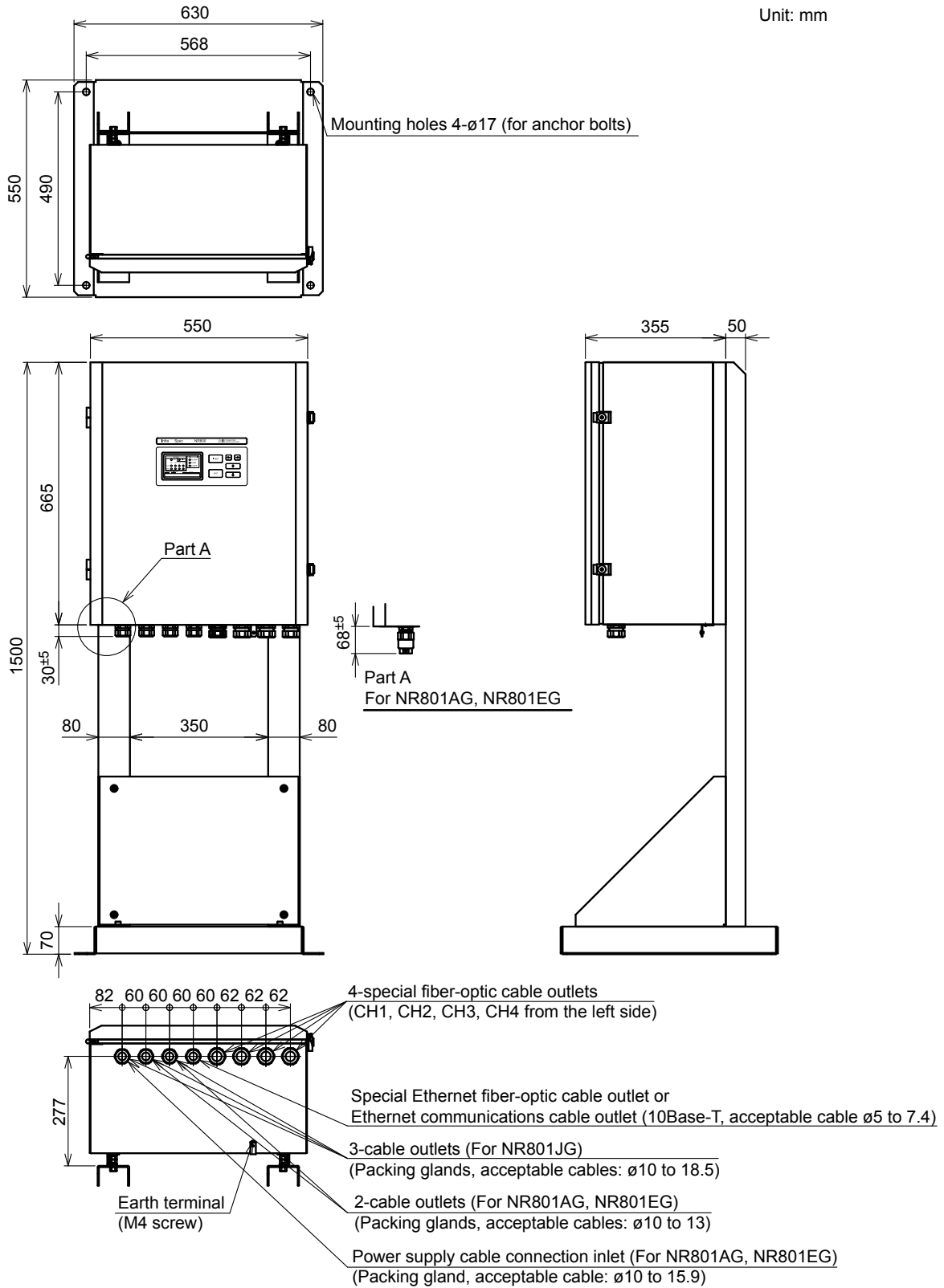

**(2) Explosion-proof model (NR805\*G type)**

- Without brackets (Suffix code: A)

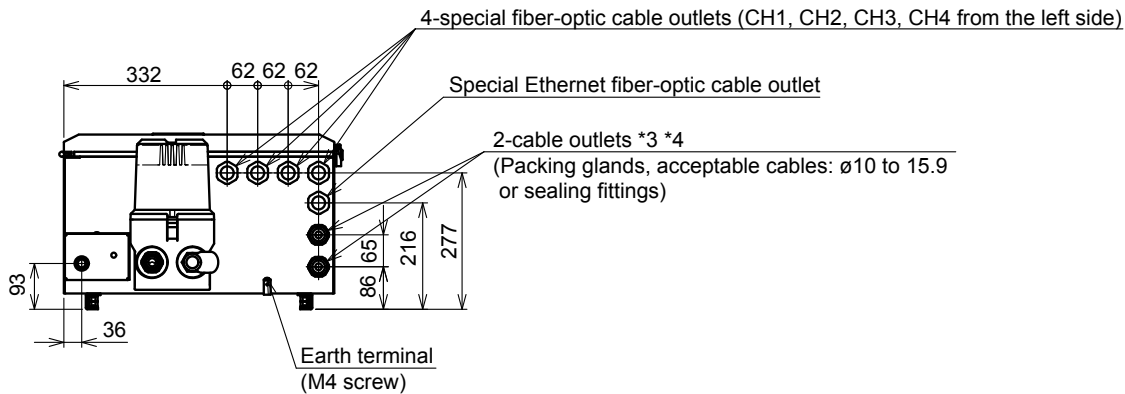
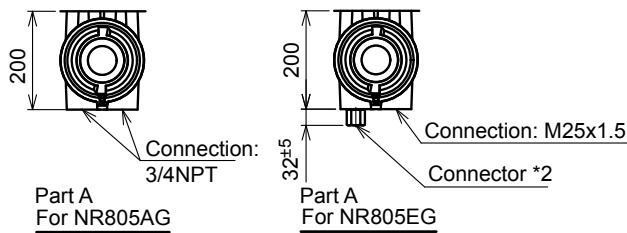
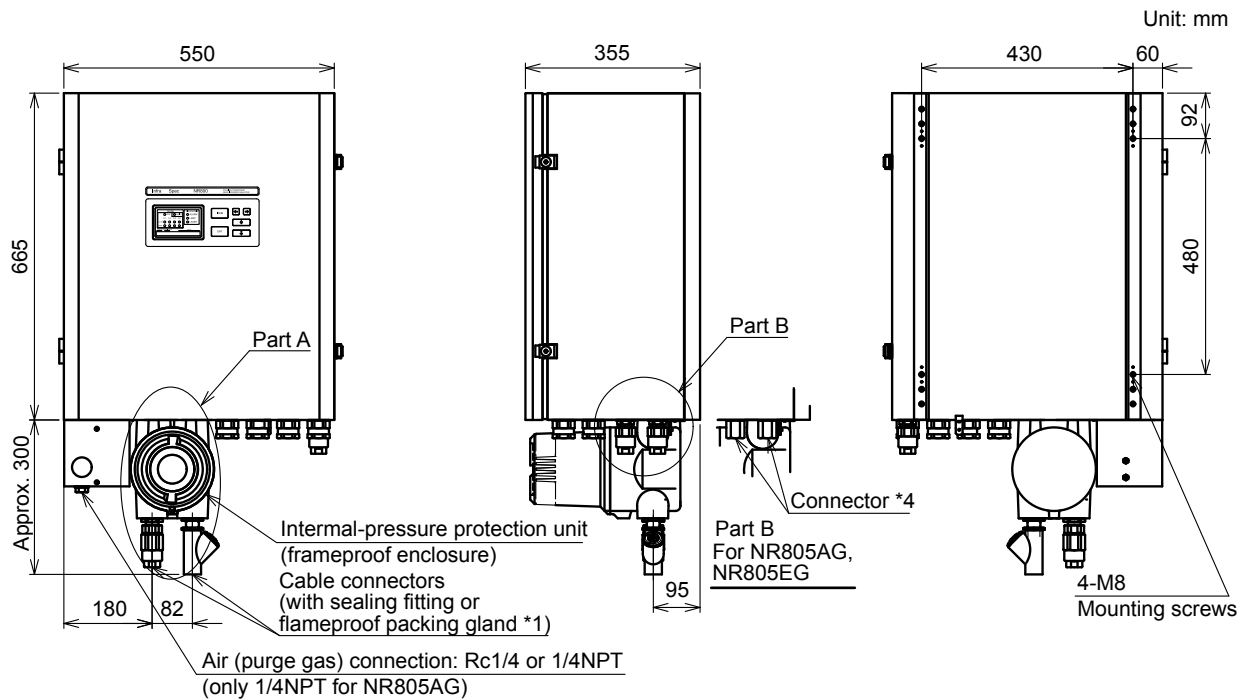

- \*1: The cable OD for flameproof packing gland is ø8 to ø15.9 mm.
- \*2: Select the connector from the following.  
3/4NPT, PG21 or G3/4
- \*3: In the case of NR805AG or NR805EG, Since attached ferrite core are used, the practical cable OD is up to ø13 mm.
- \*4: In the case of NR805EG, select the connector from the following.  
3/4NPT, PG21, G3/4 or M25x1.5  
The connector of NR805AG is 3/4NPT.

• With wall-mounting brackets (Suffix code: B)

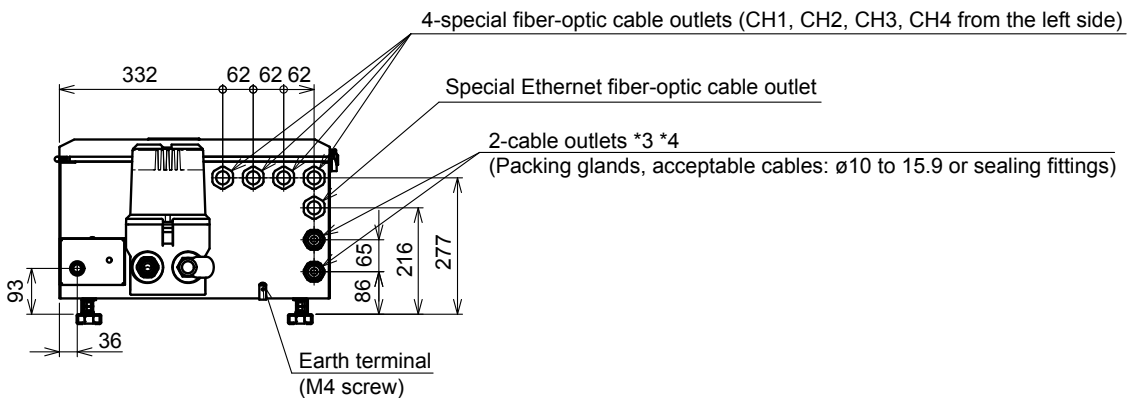
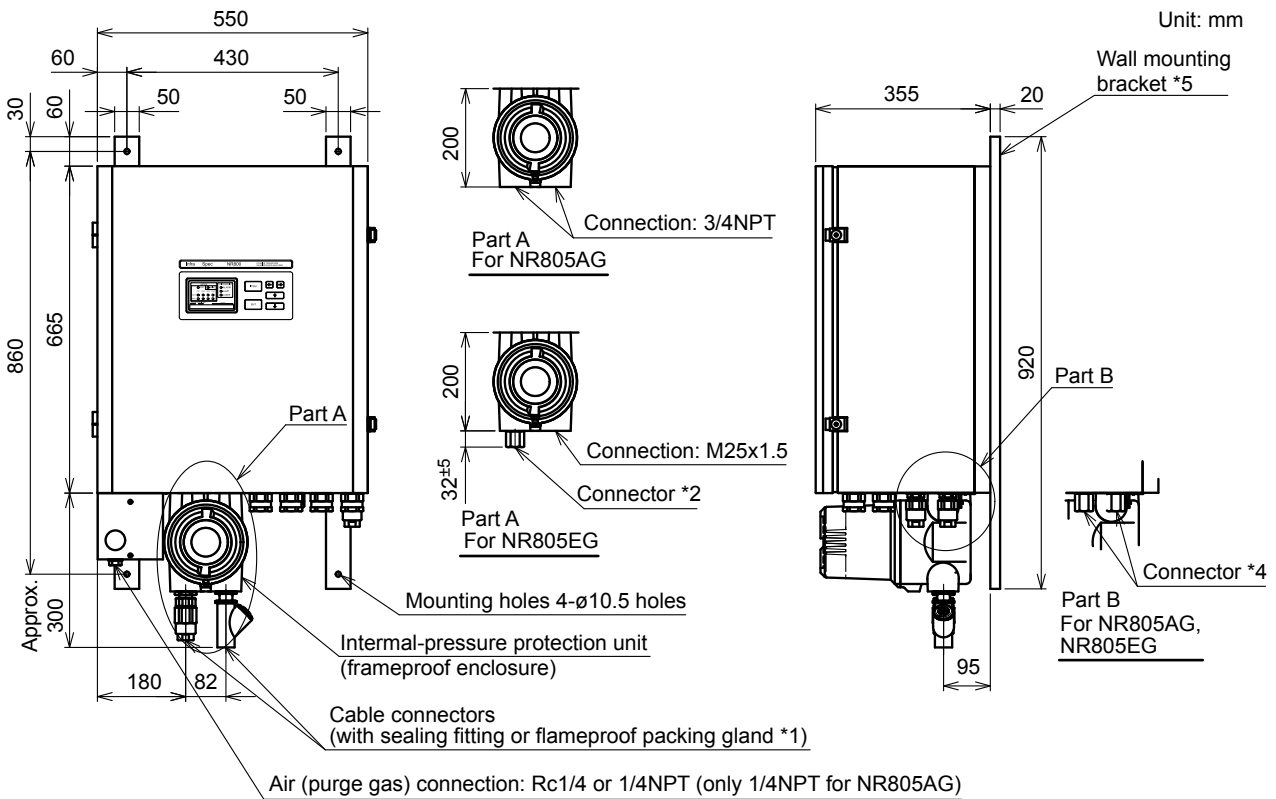

- \*1: The cable OD for flameproof packing gland is  $\phi$ 8 to  $\phi$ 15.9 mm.
- \*2: Select the connector from the following.  
3/4NPT, PG21 or G3/4
- \*3: In the case of NR805AG or NR805EG, Since attached ferrite core are used, the practical cable OD is up to  $\phi$ 13 mm.
- \*4: In the case of NR805EG, select the connector from the following.  
3/4NPT, PG21, G3/4 or M25x1.5  
The connector of NR805AG is 3/4NPT.
- \*5: The wall construction should be withstood a force of four times the weight of the NR800.

- With free standing rack (Suffix code: C)

Unit: mm

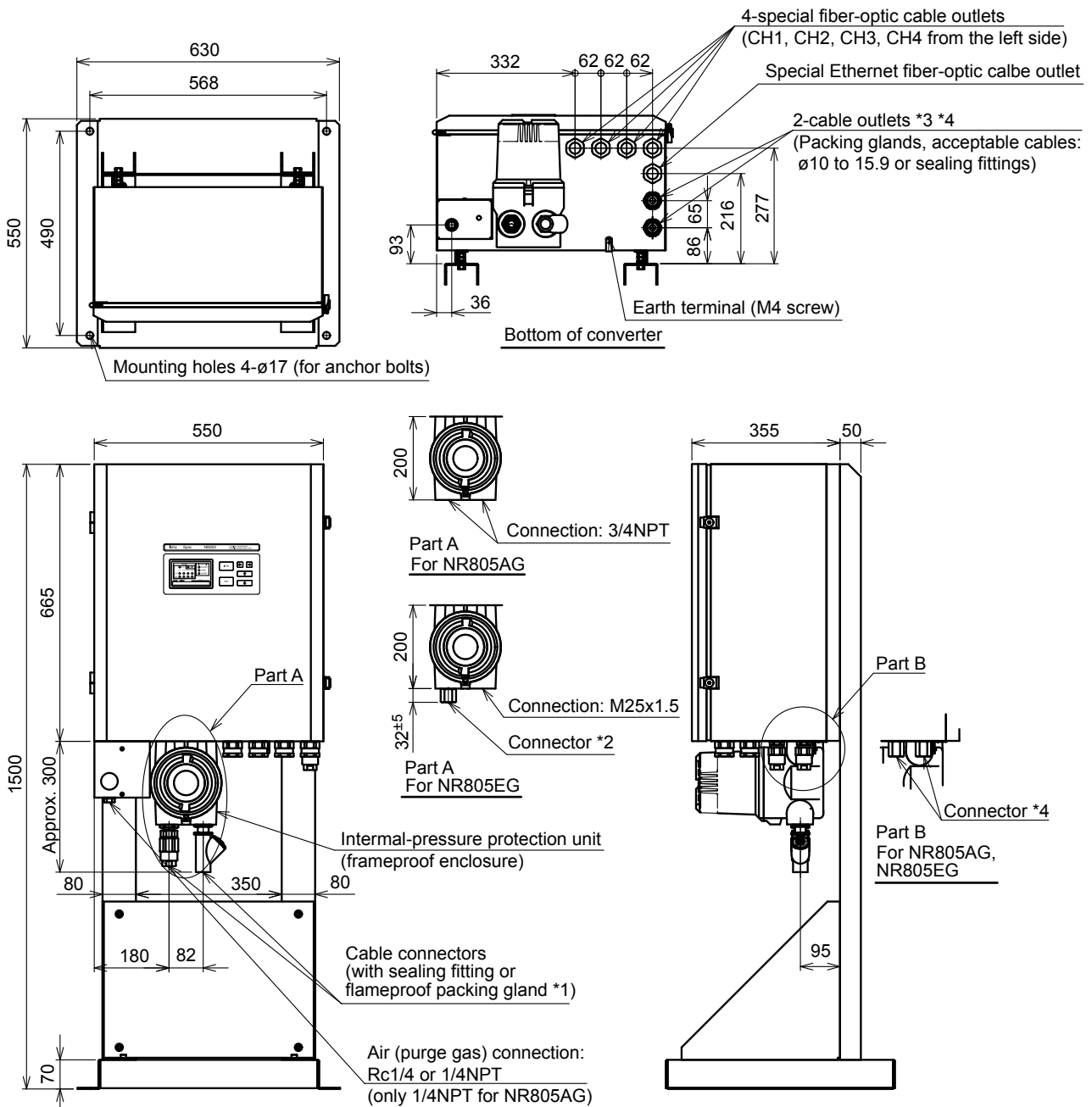

- \*1: The cable OD for flameproof packing gland is ø8 to ø15.9 mm.
- \*2: Select the connector from the following.  
3/4NPT, PG21 or G3/4
- \*3: In the case of NR805AG or NR805EG, Since attached ferrite core are used, the practical cable OD is up to ø13 mm.
- \*4: In the case of NR805EG, select the connector from the following.  
3/4NPT, PG21, G3/4 or M25x1.5  
The connector of NR805AG is 3/4NPT.

## 2.2 I/O Unit

### 2.2.1 Overview

The I/O unit is an input/output interface between the analyzer and external monitor/control system such as DCS. The I/O unit connects NR800 converter to serial communications (RS-422). Up to two I/O units can be connected to the Analyzer, and one of which can incorporate the contact input for stream switching and analogue input for compensation options.

### 2.2.2 Specifications

Power supply: See section "3. Utility Specifications".  
 Insulation resistance: 5 MΩ or more, 500 V DC  
 Withstand voltage: 1500 V AC for 1 min.

Analogue output:

Output data: Measurement results (Properties and concentration)

Number of outputs: 0 to 40

Output specifications:

Item	Description
Output range	4 to 20 mA DC (3.0 to 21.0 mA DC, Floating-common type)
Isolation method	Between output terminals and internal circuit: Photo coupler isolation Between output terminals: non-isolated, Common negative
Withstand voltage	500 V DC for 1 min.
Allowable load resistance	600 Ω or less
12-bit D/A converter resolution	5.7 μA
System accuracy	±0.5 % of full scale

Separately, 24V DC power supply is required (see section "2.2.3. Model and Suffix codes" and "3. Utility Specifications").

Contact output:

Alarm	Quantity of outputs	Alarm	Quantity of outputs
General	1	Outlier	4
Communication failure	1	I/O unit failure	1
Operating mode	5	-	-

Contact output specifications:

Item		Description	
I/O unit failure	Rating	24 V DC, 0.3 A	
	Action and number	1 normally open and 1 normally closed (shared common)	
Alarm, operating mode, and outlier detection	Insulation method	Mechanical isolation	
	Rated load voltage	DC	24 V
		AC	100 to 240 V
	Maximum load current	2 Amps/point, 8 Amps/common	
	Servicing life	Mechanical	At least 20 million actions
		Electrical	At least 100 thousand actions
	Surge killer	None	
	Number per common	8 points/common	
External power supply	Not required.		

Contact input:

Description:

Stream identification for multi-stream sampling unit :

8 points, status signals to identify sample streams that pass through measurement cells.

Measurement enabled (stream valid):

4 points, status signals to confirm that samples inside the measurement cells are ready for measurement.

Input specifications:

Item	Description
Input type	Voltage free contact
Common terminal	Common to 8 points
Isolation method	Transformer isolation
Withstand voltage	Between external connectors collectively and internal circuit: 500 V DC for 1 min.
Off-state open-circuit voltage	5 to 7 V
On-state load current	1 to 3 mA
On-state load resistance	200 Ω or smaller
Off-state load resistance	100 Ω or larger

Provide external contact-input signals meeting the above requirements.

Analogue input:

Input data and number: Analogue output compensation signal, 4 points

Input specifications

Item	Description
Input range (actual)	1 to 5 V DC (-0.25 to 5.25 V DC)
Isolation method	Between input terminals and internal circuit: photo coupler isolation Between input terminals: non-isolated, negative common
Withstand voltage	500 V DC for 1 min.
Input resistance	1 MΩ
12-bit A/D converter resolution	1 to 5 V DC: 1.4 mV
System accuracy	±0.5 % of full scale at 0 to 40°C

Installation requirements: See chapter 4.

Mounting:

Wall mounting

External connection terminal: M3.5 screw

Drip-proof and dust-proof construction:

IP4X (with enclosure)

2.2.3 Model and Suffix codes

(1) NR893AG: for NR801AG and NR805AG analyzer

Model	Suffix Code	Option Code	Description
NR893AG	.....	.....	IO unit (non explosion-proof)
Language	-E	.....	English
Analyzer	1 2	..... .....	NR805AG (Explosion-proof model) (*1) NR801AG (General Purpose model)
Contact input for stream switching	A B	..... .....	Available None
Analogue input for compensation	A B	..... .....	Available None
Number of analogue outputs	-00 -04 -08 -12 -16 -20 -24 -28 -32 -36 -40	..... ..... ..... ..... ..... ..... ..... ..... ..... ..... ..... .....	None 4 8 12 16 20 24 28 32 36 40
Enclosure	-A -B -C	..... ..... .....	Number of analog outputs: 0 to 12 Number of analog outputs: 0 to 28 Number of analog outputs: 0 to 40
-	-N	.....	Always "-N"

\*1: Always specify 1 for use with an explosion-proof model. This blocks the communication signal upon receiving a power-off signal from the Analyzer, thus ensuring the explosion-proof integrity of the analyzer.

(2) NR893EG: for NR801EG and NR805EG analyzer

Model	Suffix Code	Option Code	Description
NR893EG	.....	.....	IO unit, CE marking (non explosion-proof)
Language	-E	.....	English
Analyzer	1 2	..... .....	NR805EG (Explosion-proof model) (*1) NR801EG (General Purpose model)
Contact input for stream switching	A B	..... .....	Available None
Analogue input for compensation	A B	..... .....	Available None
Number of analogue outputs	-00 -04 -08 -12 -16 -20 -24 -28 -32 -36 -40	..... ..... ..... ..... ..... ..... ..... ..... ..... ..... .....	None 4 8 12 16 20 24 28 32 36 40
Enclosure	-C	.....	Always "-C"
-	-N	.....	Always "-N"

\*1: Always specify 1 for use with an explosion-proof model. This blocks the communication signal upon receiving a power-off signal from the Analyzer, thus ensuring the explosion-proof integrity of the analyzer.

(3) NR893JG: for NR801JG and NR805JG analyzer

Model	Suffix Code	Option Code	Description
NR893JG	.....	.....	IO unit (non explosion-proof)
Language	-E	.....	English
	-J	.....	Japanese
Analyzer	1	.....	NR805JG (Explosion-proof model) (*1)
	2	.....	NR801JG (General Purpose model)
Contact input for stream switching	A	.....	Available
	B	.....	None
Analogue input for compensation	A	.....	Available
	B	.....	None
Number of analogue outputs (*2)	-00	.....	None
	-04	.....	4
	-08	.....	8
	-12	.....	12
	-16	.....	16
	-20	.....	20
	-24	.....	24
	-28	.....	28
	-32	.....	32
	-36	.....	36
-40	.....	40	
-	-N	.....	Always "-N"
-	-N	.....	Always "-N"
Option		/C	With enclosure included 24VDC power supply unit for analog output. (*2)

- \*1: Always specify 1 for use with an explosion-proof model. This blocks the communication signal upon receiving a power-off signal from the Analyzer, thus ensuring the explosion-proof integrity of the analyzer.
- \*2: Separate 24V DC power supply required when using an analogue output and option code "/C" are not specified. (see chapter 3).

2.2.4 External dimensions and weight:

(1) NR893AG, NR893EG

Paint color:Light beige (Munsell 5Y 7/ 1 or equivalent)

Unit mm

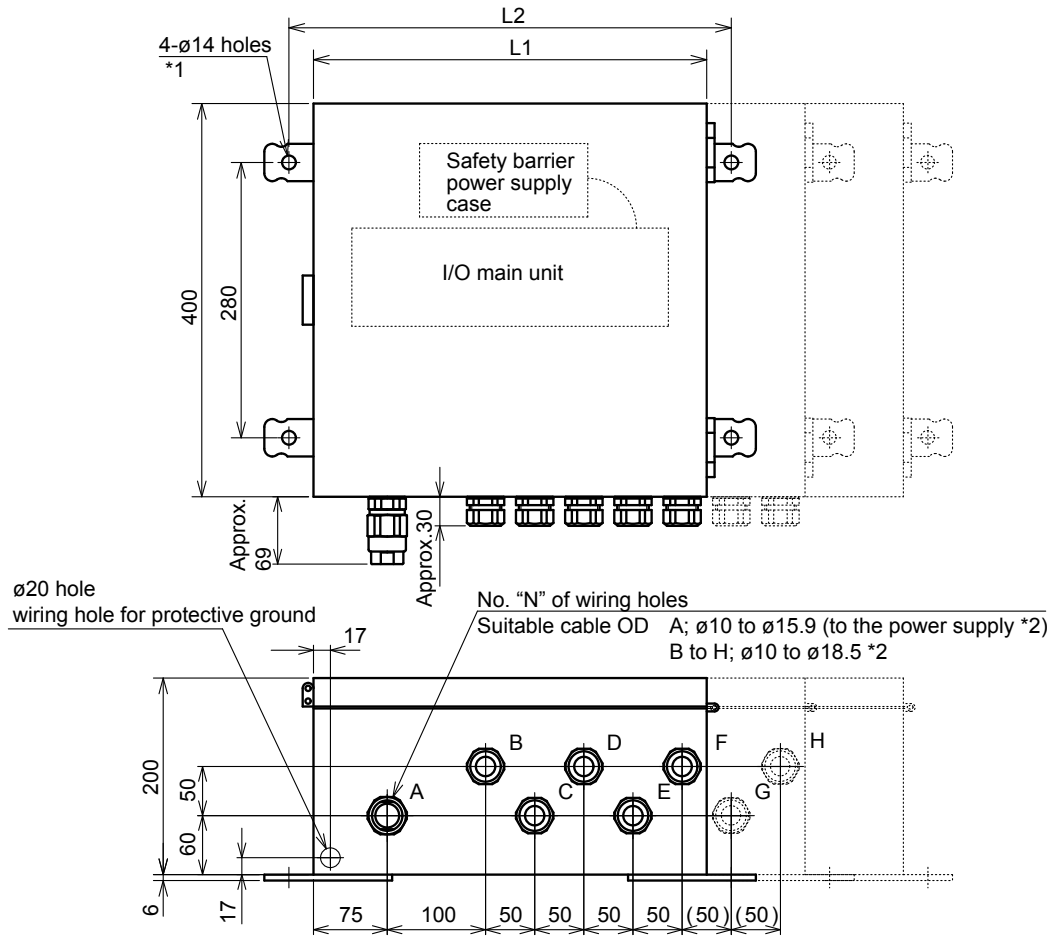

Number of Analogue Outputs	Enclosure width	Mounting holes (width apart)	Number of wiring holes	Approximate Weight	Applicable model name
	L1	L2	N		
00, 04, 08, 12	400	450	6 (A to F)	15.5 kg	NR893AG
16, 20, 24, 28	500	550	7 (A to G)	17.5 kg	NR893AG
32, 36, 40 *3	600	650	8 (A to H)	20.0 kg	NR893AG NR893EG

\*1: The wall construction should be withstood a force of four times the weight of the NR800.  
 \*2: Since attached ferrite core are used, to practical cable OD are ø9 or ø13.  
 \*3: In the case of NR893EG, only the enclosure which the Number of analogue outputs in MS-code are "32", "36" or "40" is provided.

**(2) I/O unit Without enclosure (only model 893JG)**

- For Explosion proof analyzer unit
- The size of IO unit for general purpose analyzer unit is the same as above figure but RS-422/232C converter power supply case removed.

Paint color: Baseplate, RS-422/232C converter power supply case;

Module colors: Light cobalt blue (Munsell 6.2PB4.6/ 8.8 or equivalent), lamp black (Munsell 0.8Y2.5/0.4 or equivalent)

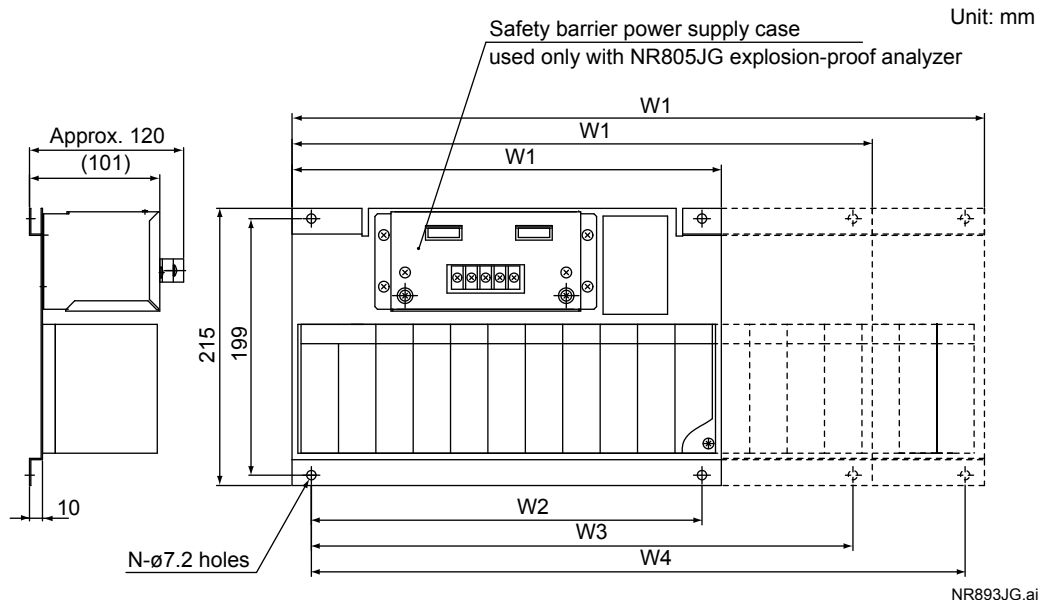

**Base Unit Mounting**

Number of Analogue Outputs	Overall width	Mounting holes				Approximate Weight
	W1	W2	W3	W4	N (Number)	
00, 04, 08, 12	333	303	-	-	4	6.5 kg
16, 20, 24, 28	450	303	420	-	6	7.0 kg
32, 36, 40	537	303	-	507	6	7.5 kg

Note: The wall construction should be withstood a force of four times the weight of the NR800.

**(3)With enclosure (Option code: /C)**

Paint color:Light beige (Munsell 5Y 7/ 1 or equivalent)

Unit: mm

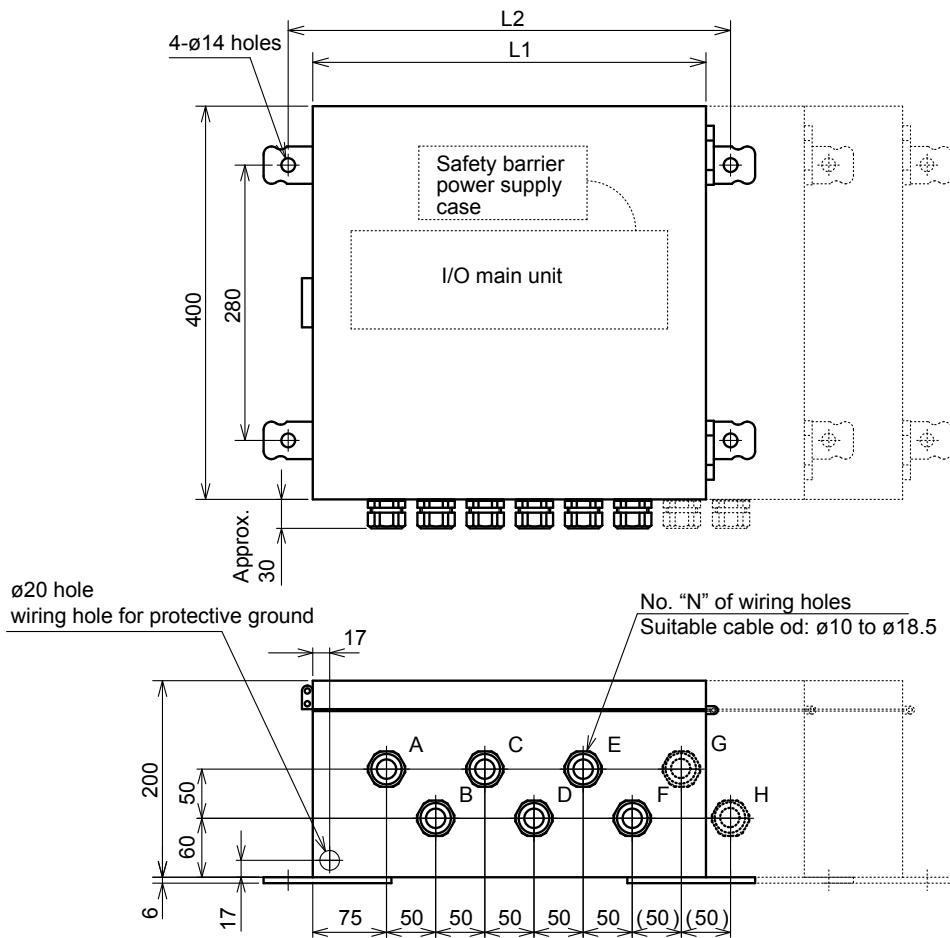

Number of Analogue Outputs	Enclosure width	Mounting holes (width apart)	Number of wiring holes	Approximate Weight
	L1	L2	N	
00, 04, 08, 12	400	450	6	15.5 kg
16, 20, 24, 28	500	550	7	17.5 kg
32, 36, 40	600	650	8	20.0 kg

## 2.3 Measurement Cells

### 2.3.1 Flow through Cell

#### (1) Specifications

Optical path length:	1, 2, 5, 10, or 20 mm
Fiber-optic connector:	FC type
Wetted part material:	Fluorine rubber, Kalrez 4079, SUS316, PTFE, Borosilicate crown glass, or Sapphire
Sample pressure range:	Atmospheric pressure up to 1.9 MPa G
Sample temperature range:	-5°C to +80°C (It vary by the materials of O-ring. Contact Yokogawa for further information.)
Sample connection:	Female Rc1/4
Installation angle:	Vertical
Installation location requirements:	See section 4.
Weight:	Approx. 3 kg

#### (2) Model and Suffix Codes

Model	Suffix Code	Option Code	Description
<b>NR510</b>	.....	.....	Flow through cell
Window material and optical path length	-B00	.....	Borosilicate crown glass, 10 mm, with variable optical path adapter (1, 2, 5, or 20 mm)
	-B01	.....	Borosilicate crown glass, 1 mm
	-B02	.....	Borosilicate crown glass, 2 mm
	-B05	.....	Borosilicate crown glass, 5 mm
	-B10	.....	Borosilicate crown glass, 10 mm
	-B20	.....	Borosilicate crown glass, 20 mm
	-S00	.....	Sapphire, 10 mm, with variable optical path adapter (1, 2, 5, or 20 mm)
	-S01	.....	Sapphire, 1 mm
	-S02	.....	Sapphire, 2 mm
	-S05	.....	Sapphire, 5 mm
	-S10	.....	Sapphire, 10 mm
-S20	.....	Sapphire, 20 mm	
Body material	SUS	.....	Stainless steel, SUS316
O-ring material	-B	.....	Fluorine rubber
	-K	.....	Kalrez 4079
-	-N	.....	Always "-N
-	-N	.....	Always "-N

#### (3) External Dimensions

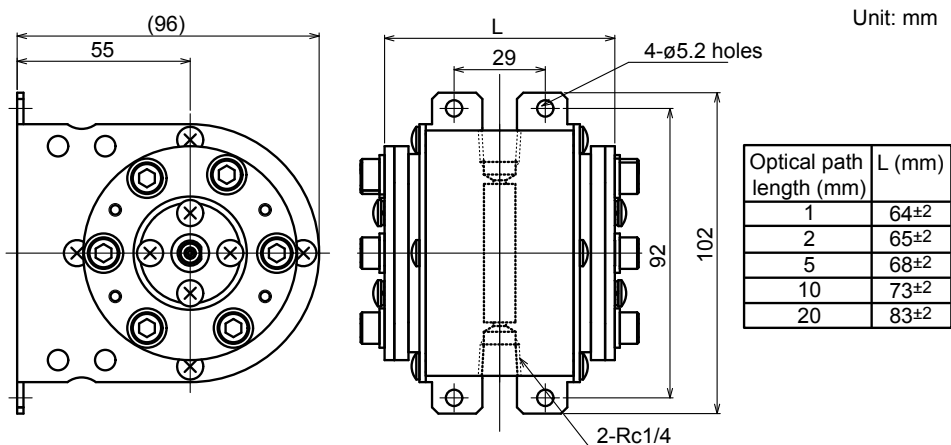

### 2.3.2 Flow through Cell with Constant Temperature Water Tube

#### (1) Specifications

- Optical path length: 1, 2, 5, 10, or 20 mm
- Fiber-optic connector: FC type
- Wetted part material: Fluorine rubber, Kalrez 4079, SUS316, PTFE, Borosilicate crown glass, or Sapphire
- Sample pressure range: Atmospheric pressure up to 0.19 MPa
- Sample temperature range: +5°C to +80°C (It vary by the materials of O-ring. Contact Yokogawa for further information.)
- Constant water temperature range: +5°C to +80°C (It vary by the materials of O-ring. Contact Yokogawa for further information.)
- Sample connection: Female Rc1/4
- Connection for water with constant temperature: 6-mm outside diameter, copper tube
- Installation angle: Vertical
- Installation location requirements: See section 4.
- Weight: Approx. 3 kg

#### (2) Model and Suffix Codes

Model	Suffix Code	Option Code	Description
<b>NR512</b>	.....	.....	Flow through cell with constant temperature water tube
Window material and optical path length	-B00	.....	Borosilicate crown glass, 10 mm, with variable optical path adapter (1, 2, 5, or 20 mm)
	-B01	.....	Borosilicate crown glass, 1 mm
	-B02	.....	Borosilicate crown glass, 2 mm
	-B05	.....	Borosilicate crown glass, 5 mm
	-B10	.....	Borosilicate crown glass, 10 mm
	-B20	.....	Borosilicate crown glass, 20 mm
	-S00	.....	Sapphire, 10 mm, with variable optical path adapter (1, 2, 5, or 20 mm)
	-S01	.....	Sapphire, 1 mm
	-S02	.....	Sapphire, 2 mm
	-S05	.....	Sapphire, 5 mm
	-S10	.....	Sapphire, 10 mm
-S20	.....	Sapphire, 20 mm	
Body material	SUS	.....	Stainless steel, SUS316
O-ring material	-B	.....	Fluorine rubber
	-K	.....	Kalrez 4079
-	-N	.....	Always "-N
-	-N	.....	Always "-N

#### (3) External Dimensions

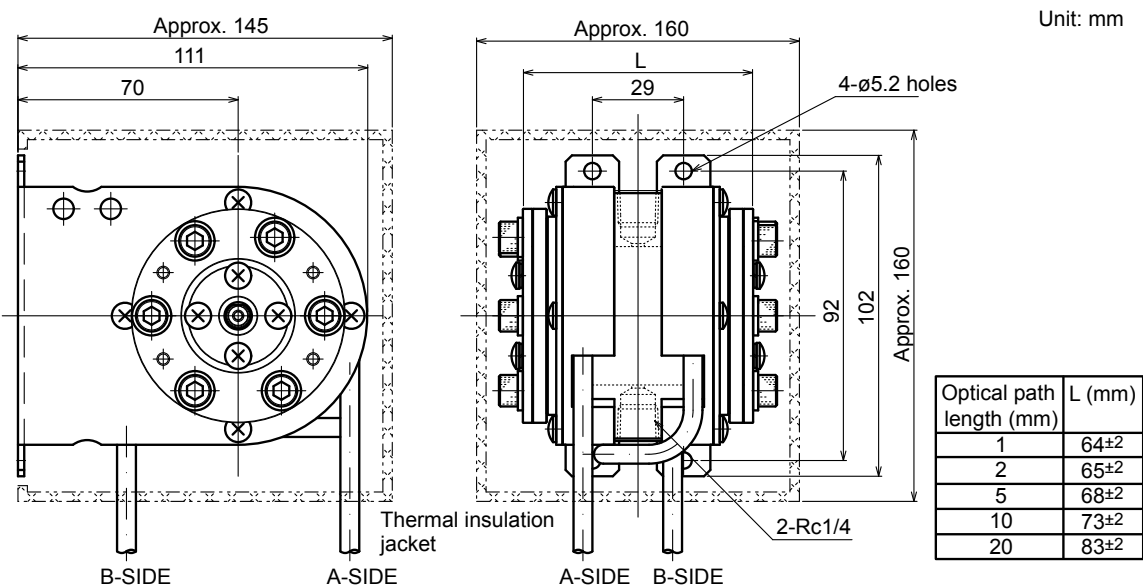

### 2.3.3 In-situ probe

#### (1) Specifications

Fiber-optic connector:	FC type
Wet part material:	
Body;	Hastelloy C-276 or UNS S31603 (Stainless steel 316L)
Others;	Sapphire, Hastelloy C-276, Gold
Sample pressure range:	Atmospheric pressure to 0.98 MPa *
Sample temperature range:	Normal temperature to 80°C *
Purge gas connection:	Female 1/8 NPT x 2
Fiber-optic entrance:	Female 1 NPT
Installation angle:	Vertical (Insert portion is downward) or Horizontal
Installation location requirements:	See section 4
Weight:	Approx. 5 kg (excluding flange)
*: When the sample pressure is the outside of the range, please consult the sales person.	

#### (2) Model and Suffix Codes

FIR200/Z

#### (3) External Dimensions

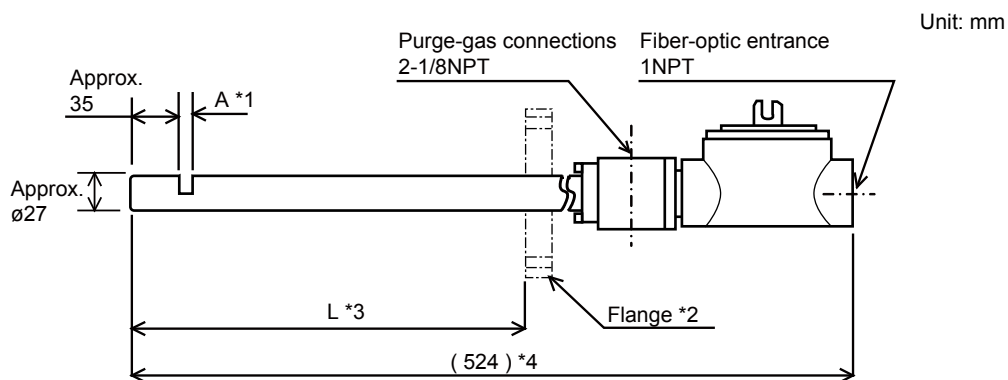

\*1: Optical path length "A": 2/5/10 mm, selectable (Dependent on sample conditions, measurement items, measurement range, etc. Consult Yokogawa.)

\*2: Mounting flange (Hastelloy C-276/UNS S31603 comparable) should be provided by customer.

\*3: Specify length "L" within the range 150 to 250 mm.

\*4: The shape and size of connection box may change.

Note 1: Keep the temperature at the connection of the fiber-optic cable at 80°C or below. If the temperature at the connection exceeds 80°C, the connection box should be purged with clean, dry air, or other appropriate measures should be taken. In this case, the connection box may be different in shape and size than the one shown above. If a fiber-optic cable for measurement is exposed to radiant heat, it should be shielded.

Note 2: Dimensions of each part may change without prior notice.

## 2.4 Fiber-optic Cables for measurement

Fiber-optic cables connect an analyzer to measurement cell. Select appropriate cables to meet your application requirement, e.g., wavelengths scanning range.

### 2.4.1 Silica Fiber-optic Cable

#### (1) Specifications

Applicable wavelength range:	900 to 2100 nm
Connector:	Double-end FC or FC-SMA type
Structure:	Dual (for sample and reference) or single (sample), two-core, protected by stainless flexible tube
Minimum bending radius:	100 mm. To reduce optical attenuation, make the radiuses along the cable as large as possible when laying cables.
Installation location requirements:	See section 4.
Cabling:	Conduit protected cabling is recommended.

**(2) Model and Suffix Codes**

**a. Single fiber-optic cable**

Model	Suffix Code	Option Code	Description
<b>NR821</b>	.....	.....	Single fiber-optic cable for wavelength of 900 to 2100 nm
Connector	-FF -FS	..... .....	Double-end FC type FC type on analyzer side and SMA type on measurement cell side
Cable length	-L005 -L010 -L020 -L030 -L050 -L100 -L150 -L200 -L300	..... ..... ..... ..... ..... ..... ..... ..... .....	5 m 10 m 20 m 30 m 50 m 100 m 150 m 200 m 300 m
-	-000	.....	Always "-000

**b. Dual fiber-optic cable**

Model	Suffix Code	Option Code	Description
<b>NR822</b>	.....	.....	Dual fiber-optic cable for wavelength of 900 to 2100 nm
Connector	-FF -FS	..... .....	Double-end FC type FC type on analyzer side and SMA type on measurement cell side
Cable length	-L005 -L010 -L020 -L030 -L050 -L100 -L150 -L200 -L300	..... ..... ..... ..... ..... ..... ..... ..... .....	5 m 10 m 20 m 30 m 50 m 100 m 150 m 200 m 300 m
-	-000	.....	Always "-000

**(3) External Dimensions**

A dual fiber-optic cable is a set of two single fiber-optic cable of the same specification.

• **Double-end FC connector**

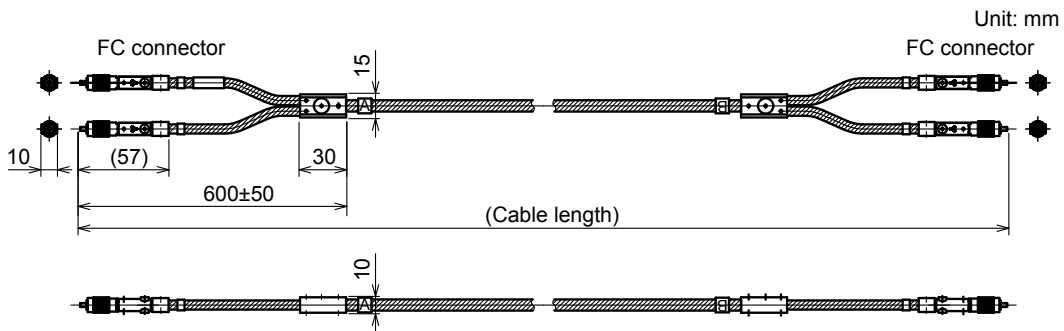

• **FC (analyzer) - SMA (measurement cell) connector**

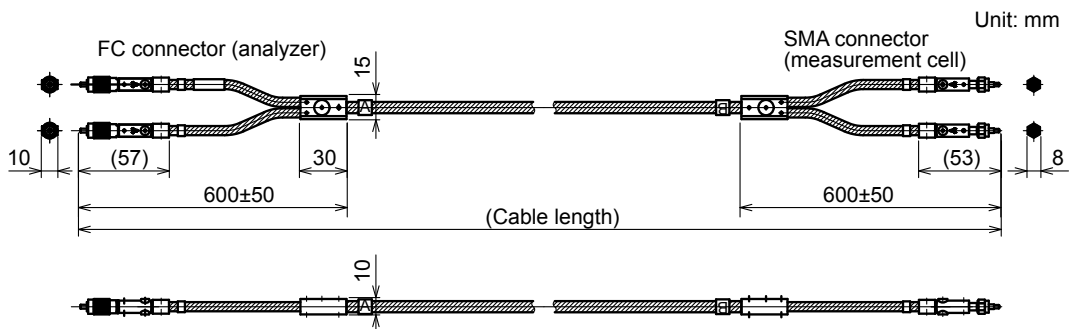

**2.4.2 Fluoride Fiber-optic Cable**

**(1) Specifications**

Applicable wavelength range: 900 to 2500 nm  
 Connector: Double-end FC type or FC-SMA type  
 Structure: Dual (for sample and reference) or single (sample), two-core, protected by stainless flexible tube  
 Minimum bending radius: Analyzer side; 100 mm, Measurement side; 120 mm  
 To reduce optical attenuation, make the radiuses along the cable as large as possible when laying cables.

Installation location requirements: See section 4.

Note: Fluoride, a material used in the NR823 and NR824 fiber-optic cables, has the deliquescence properties. When storing these cables, take appropriate measures to prevent moisture, e.g., a cable should be placed with desiccant in a sealed, moisture-barrier plastic bag and the desiccant replaced regularly.

**(2) Model and Suffix Codes (Model code to include fibers for Analyzer–Cell(probe)–Analyzer)**

**a. Single fiber-optic cable**

Model	Suffix Code	Option Code	Description
<b>NR823</b>	.....	.....	Single fiber-optic cable for wavelength of 900 to 2500 nm
Connector	-FF	.....	Double-end FC type
	-FS	.....	FC type on analyzer side and SMA type on measurement cell side
Cable length	-L003	.....	3 m
	-L004	.....	4 m
	-L005	.....	5 m
-	-000	.....	Always "-000

**b. Dual fiber-optic cable**

Model	Suffix Code	Option Code	Description
<b>NR824</b>	.....	.....	Dual fiber-optic cable for wavelength of 900 to 2500 nm
Connector	-FF	.....	Double-end FC type
	-FS	.....	FC type on analyzer side and SMA type on measurement cell side
Cable length	-L003	.....	3 m
	-L004	.....	4 m
	-L005	.....	5 m
-	-000	.....	Always "-000

**(3) External Dimensions**

A dual fiber-optic cable is a set of two single fiber-optic cable of the same specification. (Connect the longer end to the measurement cell side.)

• **Double-end FC connector**

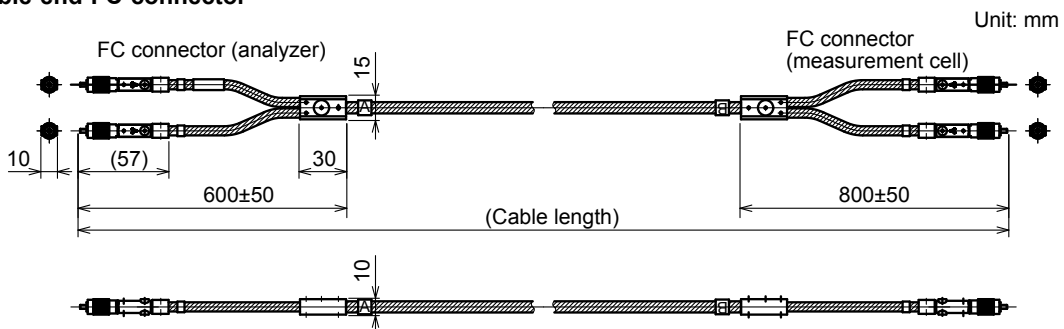

• **FC (analyzer) - SMA (measurement cell) connector**

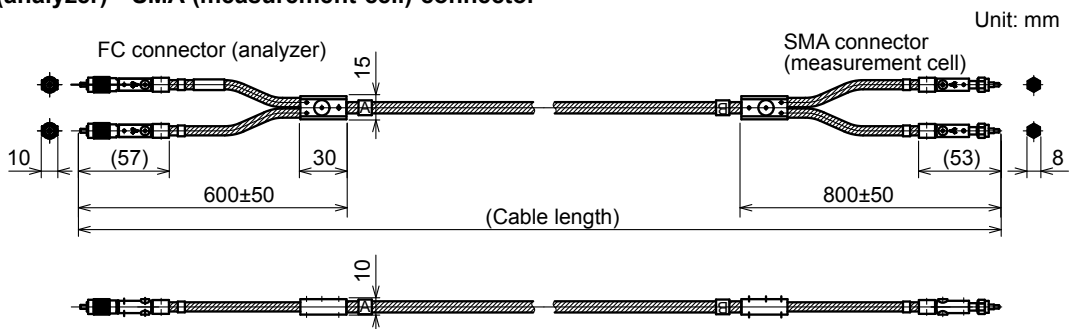

**2.5 RS422-to-RS232C Converter (Part Number: K9404LA or K9404LD)**

This unit converts output signals of the analyzer main unit from the RS422 format to the RS232C format for personal computer or DCS communication and also blocks communication signals when it receives a power-off signal from the Analyzer, thus ensuring the explosion-proof integrity.

**2.5.1 Specifications**

- Power supply: See section 3.
  - Signal terminals: Analyzer main unit side (RS422): M4, output side (RS232C): Female Dsub 25-pin
  - Grounding type: 100 Ω or lower
  - Installation location requirements: See section 4.
  - Housing structure: Desktop (K9404LA), Screw cramp (K9404LD)
  - Weight: Approx. 2 kg
- Note: The converter does not carry the CE Marking. An appropriate housing should be provided by customer, if necessary.

**2.5.2 Terminal Diagram**

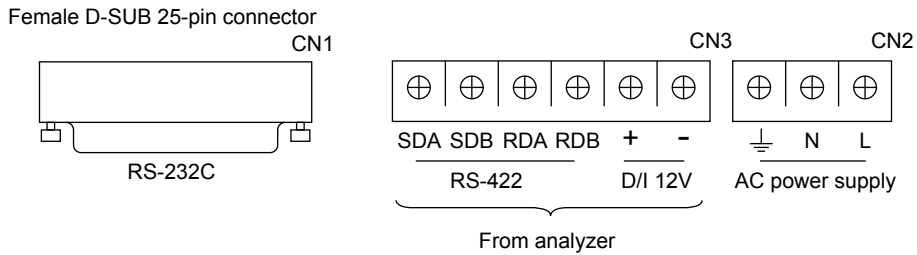

**2.5.3 RS232C Communication Straight Cable**

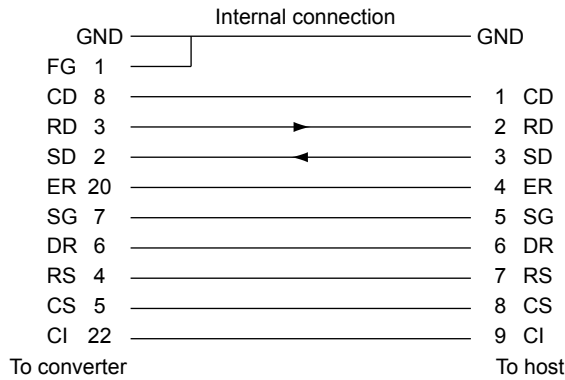

**2.5.4 External Dimensions**

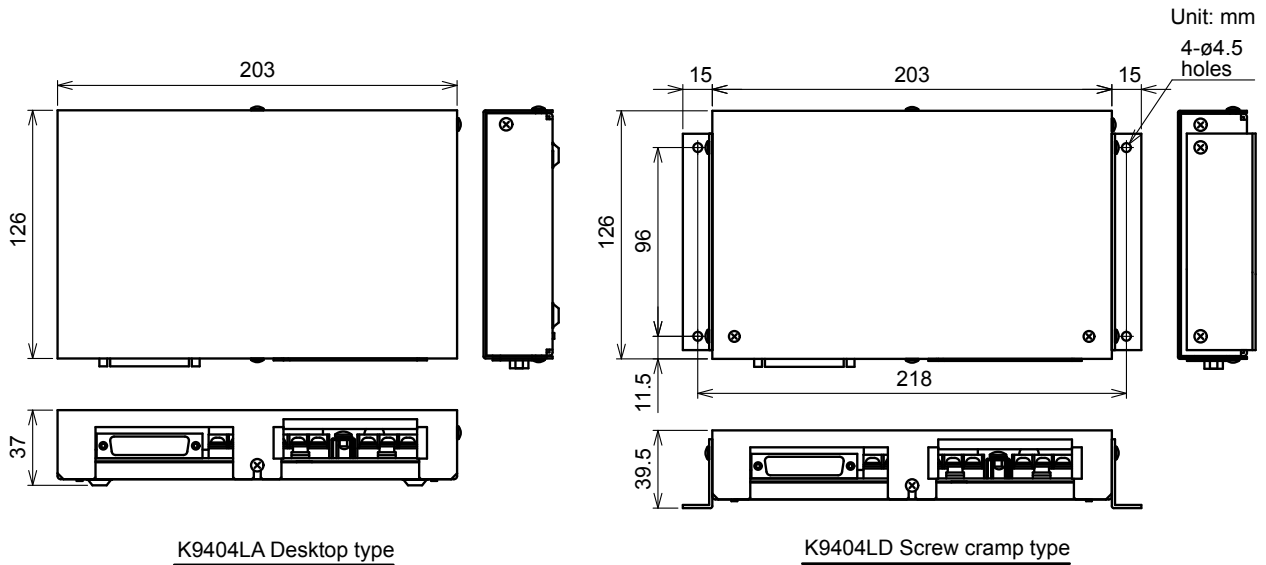

## 2.6 Ethernet Fiber-optic Cable

Cable for Ethernet communication between the analyzer and the engineering PC.

### 2.6.1 Specifications

Length: Up to 20 m  
 Connector: ST type  
 Structure: Two-core, protected by stainless flexible tube  
 Installation location requirements: See section 4.  
 Minimum bending radius: 50 mm. To reduce optical attenuation, make the radiuses along the cable as large as possible when laying cables.

### 2.6.2 Model and Suffix Codes

Model	Suffix Code	Option Code	Description
<b>NR895</b>	.....	.....	Ethernet fiber-optic cable
Length *1	-L003	.....	3 m
	-L005	.....	5 m
	-L010	.....	10 m
	-L020	.....	20 m
-	-000	.....	Always "-000
Option		/JB	With junction box *2

- \*1: For a total cable distance of 20 m or longer, an additional fiber-optic cable (fitted with ST connectors) must be provided by the user.  
 See chapter 6.2 for the cable specification of user provisions.
- \*2: The Junction box is for connection between an NR895 fiber-optic cable and the additional cable.

### 2.6.3 External Dimensions

#### (1) Fiber-optic Cable

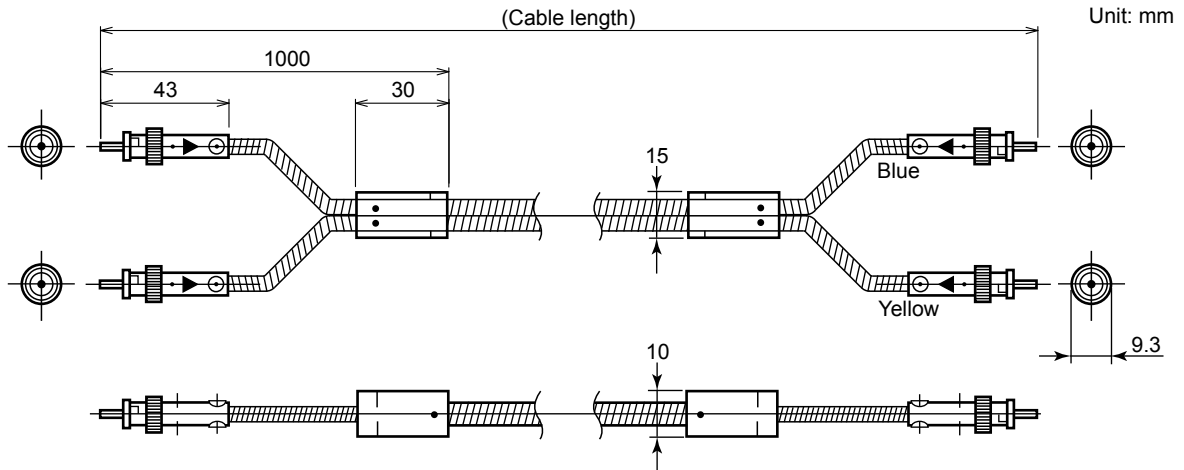

(2) Junction Box for Ethernet fiber-optic cables (Option code: /JB)

Unit : mm

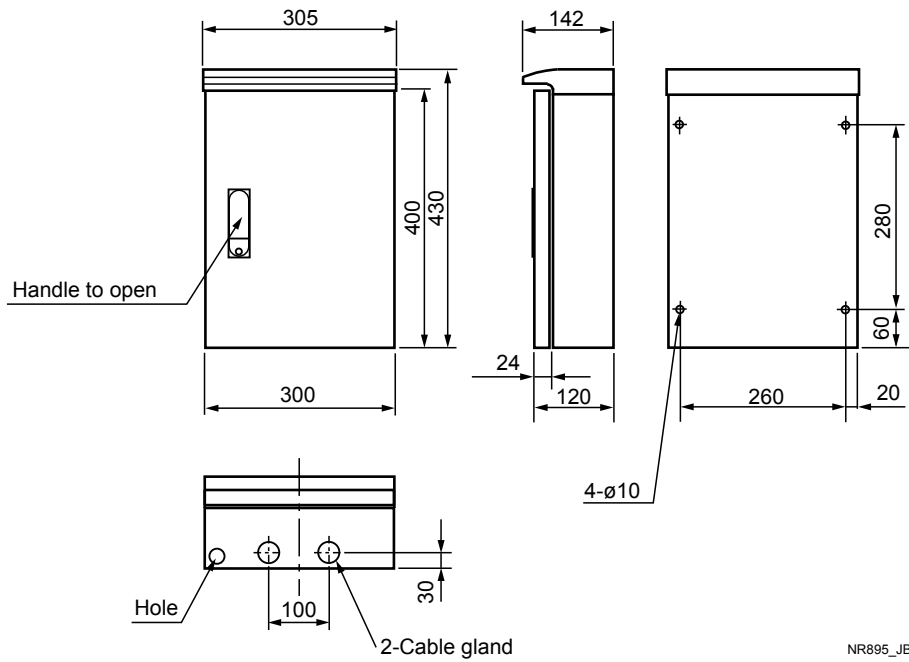

- Housing structure: IP44
- Coating: Epoxy resin coating
- Paint color: Light beige (equivalent to Munsell 5Y7/1)
- Material: Iron
- Weight: Approx. 10 kg

NR895\_JB.ε

**2.7 SpectLand 2 Measurement and Maintenance Software**

**2.7.1 Overview**

SpectLand 2 is an application software that controls NR800 operation and monitoring on a PC. It displays the analyzer status, and instructs measurement and sets parameters for the analyzer. To use SpectLand 2, first install it in the Engineering PC. The continuous operation of SpectLand 2 for extended periods of time is not guaranteed.

**Main Features**

- Instructs the analyzer to measure spectra, save data and display. The measured spectra can be used to generate calibration models.
- Shows trend graphs of the measurements and saves them to files during a continuous measurement.
- Sets parameters for continuous measurement.
- Displays various data of the analyzer, such as operating modes, alarm status, and maintenance data.
- Instructs the analyzer to perform such tasks as operation mode change, spectra measurement, and setting property information, calibration models, or measurement conditions.

**2.7.2 Main Windows**

**(1) Manual Spectrum Window**

Enables the analyzer to measure spectra, which are to be processed by Chemometrics (calibration model generation software). Also allows data to be saved to files and displayed.

**(2) Auto Spectrum Window**

Allows the user to upload spectra data to the Engineering PC during continuous measurement upon receiving a signal at periodic intervals, outlier detection, or a property value variation failure. This data is displayed for each measuring channel.

**(3) Power Spectrum Window**

It displays power spectra. This window is available for UB level (equipment supervisor) users.

**(4) Interferogram Window**

It displays interferogram data collected. This window is available for UB level users.

**(5) Real-time Trend Windows**

Display measurement values of Nos. 1 to 6 and Nos. 7 to 12 components in two separate trend graph windows for each stream. Up to 10 windows can be open at the same time.

**(6) Historical Trend Windows**

Display historical trend data saved. Trend data of 24 hours for each stream is saved to a file. Up to 4 windows can be open at the same time.

**(7) Parameter Window**

Displays the current parameter settings for the analyzer. In addition, UB level users can change the settings.

**(8) Alarm Status/History Windows**

The Alarm Status window displays the active alarms for the analyzer, while the Alarm History window displays all the past alarms. The alarm history can be deleted with commands.

**(9) Tab-controlled Maintenance Window**

Displays the A/D reference value and servo-related data of the analyzer. This window is available for UC level users.

**(10) Tab-controlled Communication Status Window**

Displays the communication status between the personal computer and the analyzer. This window is available for UC level (maintenance) users.

**2.7.3 Model and Suffix Codes**

Model	Suffix Code	Option Code	Description
NR831	.....	.....	SpectLand 2 measurement and maintenance software
Language	-E -J	..... .....	English Japanese
-	-N	.....	Always "-N
-	-N	.....	Always "-N

Package contents: One CD-ROM  
One user's manual

**2.8 Unscrambler Analysis and Calibration Model Generating Software**

**2.8.1 Specifications**

- Calibration model generating technique: Partial least square (PLS) and others

**2.8.2 Model and Suffix Codes**

Model	Suffix Code	Option Code	Description
NR530	.....	.....	Unscrambler analysis and calibration model generating software
Language	-E	.....	English
-	-N	.....	Always "-N
-	-N	.....	Always "-N

Package contents: Two CD-ROMs (Install disc/User's manual)  
One set of user registration document

## 2.9 Sampling Unit

Use of a sampling unit is highly recommended to ensure compatibility of the user's process sample with the measurement cell. In addition, it allows separation of the measurement cell (probe) apart from the analyzer with a fiber-optic cable up to 300 m in length. This enables selection of a measurement location independent of the analyzer. The optimum sampling unit is prepared for individual application requirements. Contact Yokogawa for further information.

### ● Example of Sampling System

The following introduces a conceptual sampling unit for measuring the properties (RON, RVP, Distillation etc.) of gasoline blending in a petroleum refinery. Note that each sampling unit should be designed for each application; designs will vary.

Measurement Sample Conditions

Item	Condition	
Fluid to be measured	Gasoline	
Sample inlet/outlet condition	Inlet pressure	0.3 to 0.9 MPa G
	Outlet pressure	0.3 to 0.9 MPa G
	Inlet temperature	0°C to +40°C

Notes

- 1: When samples do not contain free water content, a coalescer (CF1) is not required.
- 2: When samples do not have bubbles, a degasser (DG1) is not required.
- 3: If the pressure difference between the sample inlet and outlet is greater than 0.3 MPa, a sampling pump (PU1) is not required.

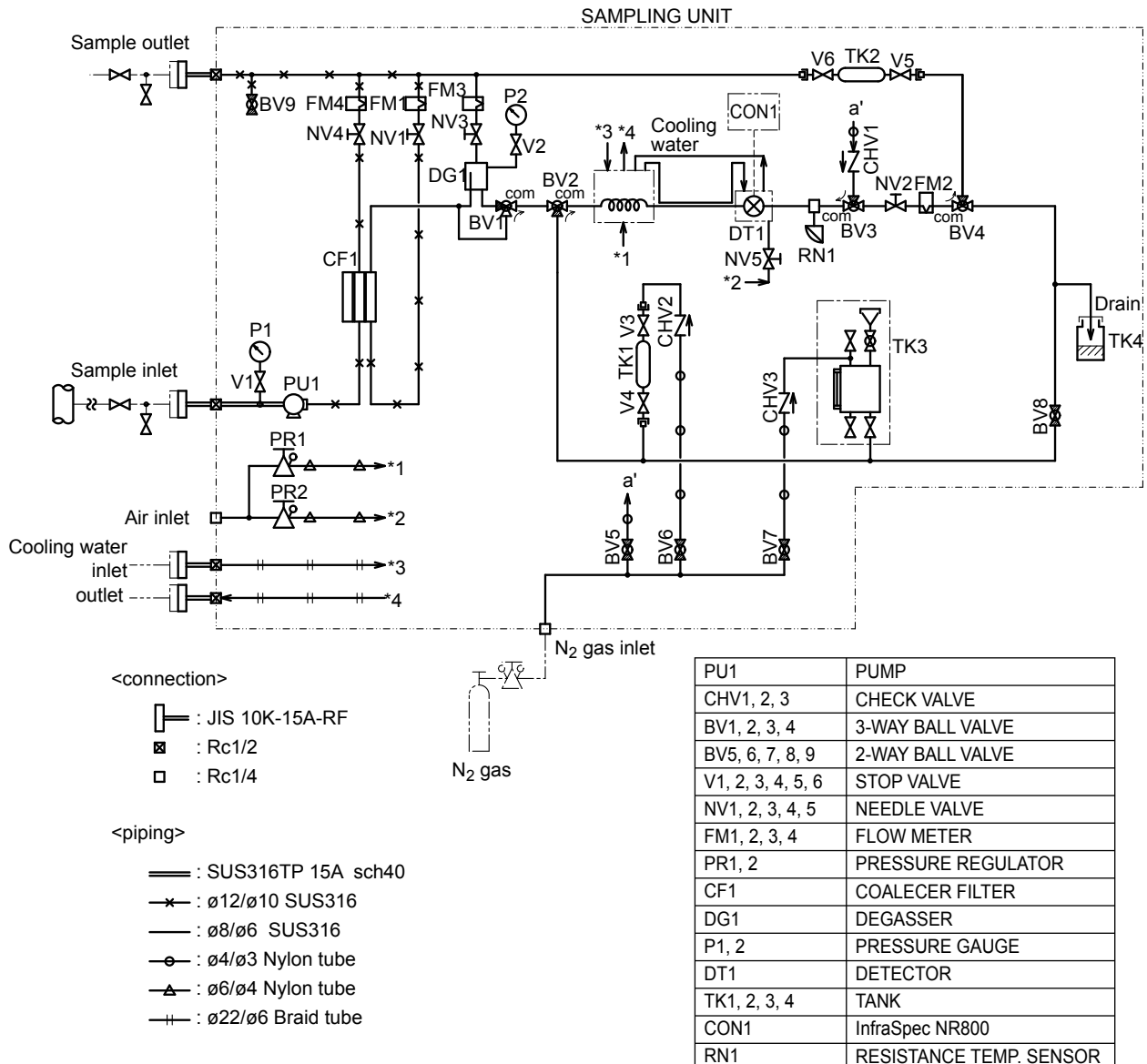

## 2.10 Auxillary Parts \*

The recommended replacement intervals for auxillary parts, listed in Section 2.10.1, Model and Suffix Codes, are set for preventive maintenance and do not guarantee the service life of parts. Actual replacement intervals for auxillary parts vary depending on operating conditions, sample condicitions, and other factors. Be sure to perform preventive maintenance based on operational status of instrument.

The auxillary parts are classified into two types: those that can be replaced by customer and those that must be replaced by a Yokogawa service engineer.

Prior to replacement, refer to the user's manual and follow the instruction therein.

\* Auxillary parts mean limited life components that are excepted to be in their wear-out failure period within 5 years under normal operating or strage conditions.

### 2.10.1 Model and Suffix Codes

Model	Suffix Code	Option Code	Description	Recommended Replacement Interval
NR8SP01	.....	.....	Auxiliary parts set for NR800	
	-01	.....	Sealing packing for converter door (for NR801AG/NR805AG/NR801JG/NR805JG)	1 year
	-02	.....	Converter cooling fan (5 pcs)	3 years
	-03	.....	Spectrometer support insulator (4 pcs)	3 years
	-04	.....	Lamp (adjusted)	5,000 hours
	-05	.....	Laser head	12,000 hours
	-06	.....	Desiccant for spectrometer (9 pcs)	1 year (Shelf life: 1 year after shipment)
	-07	.....	Desiccant for flow-through cell (10 pcs)*1	3 months
	-08	.....	Sealing packing for converter door (for NR801EG/NR805EG)	1 year
	-10	.....	O-ring for flow-through cell (JIS P38, FPM (fluorine rubber), 2 pcs)	*1, *2
	-11	.....	O-ring for flow-through cell (JIS P21, FPM (fluorine rubber), 2 pcs)	*1, *2
	-12	.....	O-ring for flow-through cell (JIS P16, FPM (fluorine rubber), 2 pcs)	*1, *2
	-13	.....	O-ring for flow-through cell (JIS P38, Kalrez 4079, 2 pcs)	*1, *2
	-14	.....	O-ring for flow-through cell (JIS P21, Kalrez 4079, 2 pcs)	*1, *2
	-15	.....	O-ring for flow-through cell (JIS P16, Kalrez 4079, 2 pcs)	*1, *2
	-16	.....	Window pane of flow-through cell (borosilicate crown glass, 2 pcs)*3	
	-17	.....	Window pane of flow-through cell (sapphire, 2 pcs)*3	

\*1: When a measurement cell is disassembled for service/cleaning, it is recommended that O-rings should be replaced.

\*2: Replacement intervals vary depending on sample composition, humidity, pressure, etc. Determine replacement intervals based on actual operational status.

\*3: If a window is scratched or fogged, replace the whole set of windows (2 pieces/set).

## 3. Utility Specifications

### 3.1 Power Supplies

#### (1) NR800 analyzer

Power supply:

100, 115, 200, 230 V AC, single phase,  
50/60 Hz( \*1)

Voltage fluctuation:

Rating  $\pm 10\%$ , 50/60  $\pm 2$  Hz

Power consumption:

Approx. 250 VA

(\*1): To be specified. See the corresponding model and suffix codes for details.

#### (2) RS422/RS232C converter

Power supply:

100 to 120 V AC or 200 to 240 V AC,  
single phase, 50/60 Hz

Voltage fluctuation:

Rating  $\pm 10\%$ , 50/60  $\pm 2$  Hz (Don't exceed  
250 V AC)

Power consumption:

Approx. 15 VA

#### (3) I/O unit

AC Power supply:

100 to 240 V AC  $\pm 10\%$ , single phase,  
50/60 Hz  $\pm 5\%$

Power consumption:

NR893AG, NR893JG with enclosure

(AO points 0 to 12): Approx. 150 VA

(AO points 16 to 28): Approx. 190 VA

(AO points 32 to 40): Approx. 220 VA

NR893EG (AO points 0 to 40): Approx. 220 VA

NR893JG without enclosure

(AO points 0 to 40): Approx. 100 VA

DC Power supply:

24 V DC  $\pm 10\%$

Power consumption:

Approx. 180 mVA / AO 4 points

\*: Required when in the NR893JG I/O unit, option code "/C" is not specified.

### 3.2 Others

#### (1) Clean, dry air for Analyzer purge (explosion-proof model)

Item	Description
Temperature	-10°C to +40°C
Pressure	0.3 to 0.9 MPa
Dew point	-20°C or lower (at pressure) Compressed air should not dew at the installation ambient temperature.
Cleanliness	Must be free from dust, corrosive, and toxic elements. Impurities, such as oil, cause damage to the optical components. Eliminate them with an activated carbon filter.
Volume;	Approx. 75 l/min (stp.)

#### (2) Clean, dry air for in-situ probe

Item	Description
Temperature	-10°C to +40°C
Pressure	Atmospheric pressure
Dew point	-20°C or lower (at pressure) Compressed air should not dew at the installation ambient temperature.
Cleanliness	Must be free from dust, corrosive, and toxic elements. Impurities, such as oil, cause damage to the optical components. Eliminate them with an activated carbon filter.
Volume;	Approx. 0.3 to 0.5 l/min (stp.). Depend on sample temperature and ambient temperature.

#### (3) Water for flow through cell with water tube;

Depend on measurement specifications. Temperature, response speed, etc.,

#### (4) Utility for sampling unit (when used)

Depend on sampling system configuration, sample temperature, response speed, etc.

## 4. Installation Location Requirements

Avoid physical shock as it may cause damage to the equipment.

### 4.1 NR800 analyzer, measurement cell, and fiber-optic cable

Item	Description
Location	Hazardous area/non-hazardous area. Outdoor/indoor. Avoid direct exposure to wind, rain, sunlight and radiation heat. Altitude 2,000 m max.
Ambient temperature	-10°C to +40°C
Ambient humidity	5% to 95% RH (no condensation)
Vibration	Install the equipment in a place with minimum vibration (vibration acceleration of 2 m/s <sup>2</sup> or less)
Atmosphere	Must not contain corrosive or toxic substances. Must be free from dust.

### 4.2 RS-422/RS-232C converter and I/O unit

Item	Description
Location	Non-hazardous area, indoor. Avoid direct exposure to wind and rain, sunlight, or radiation heat. Altitude 2,000 m max.
Ambient temperature	+5° C to +35 °C
Ambient humidity	5% to 95% RH (no condensation)
Vibration	Install the equipment in a place with minimum vibration (vibration acceleration of 2 m/s <sup>2</sup> or less)
Atmosphere	Must not contain corrosive or toxic substances. Must be free from dust.

### 4.3 Maintenance Space for NR800 Converter

When installing the converter, to facilitate operation and maintenance, provide space around it as following illustration.

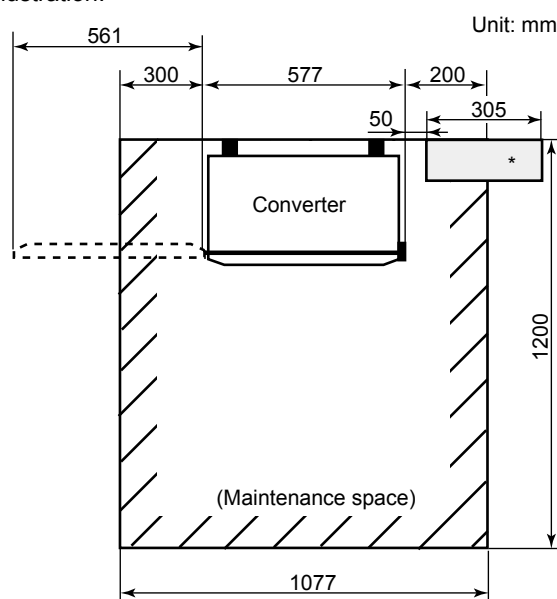

\* Junction box for Ethernet fiber-optic cables.  
(When NR895/JB is selected.) See section 2.6.3 for external dimensions.

### 4.4 Storage Requirements

Avoid physical shock as it may cause damage to the equipment.

Item	Description
Location	Indoor. Avoid direct exposure to wind and rain, sunlight, or radiation heat
Ambient temperature	-10°C to +50°C
Ambient humidity	5% to 95% RH (no condensation)
Vibration	Install the equipment in a place with minimum vibration (vibration acceleration of 2 m/s <sup>2</sup> or less)
Atmosphere	Must not contain corrosive or toxic substances. Must be free from dust.

Note: Fluoride, a material used in the NR823 and NR824 fiber-optic cables, has the deliquescence properties. When strong these cables, take appropriate measures to prevent moisture, e.g., a cable should be placed with desiccant in a sealed, moisture-barrier plastic bag and the desiccant replaced regularly.

## 5. Support for Calibration Model Generation

### 5.1 On-site Guidance of Calibration Model Generation

A Yokogawa engineer will train an user's site personnel in the procedure to generate a calibration model for one measured item using a user-provided sample with its laboratory analysis results.

### 5.2 Calibration Model Generation

Yokogawa generates a calibration model using the necessary quantity of user-provided samples with laboratory analysis results. A predefined SEP (standard error of prediction) value of  $1\sigma$  will be used as the measurement target value. The target value, sample quantity, and other details are determined separately for each application.

### 5.3 Others

Other support options for calibration model generation and maintenance include:

- Sampling test for potential users
- Maintenance contracts
- Sampling/model generation/maintenance consulting service.

Contact a Yokogawa sales representative for further information, and advice on the best solution for your needs.

## 6. Recommended Specifications for Engineering PC and related Equipments provided by user that satisfies the following requirements:

### 6.1 PC

Computer	IBM PC/AT compatible	
Operating system (OS)	Microsoft Windows 7 Professional 32 bit SP1 or Microsoft Windows Vista Business Edition	Microsoft Windows XP SP2
CPU	1 GHz or higher	
RAM	1 GB or more	256 MB or more
Hard disk space	10 GB (for program) and 25 GB (for data storage) or more	
Ethernet adapter	10 BASE-T	
Display	SVGA mode (1024 x 768 pixels or more)	
Other	CD-R drive is recommended	

#### ● Color Printer

Prepare if necessary.

#### ● Connection cables and other devices and consumables

Prepare if necessary.

## 6.2 Ethernet Communication

When fiber-optic cables are used for Ethernet communication (see section 2.6) An optical-to-electrical signal converter (wavelength: 850 nm) for a multimode fiber-optic cable that complies with Ethernet version 2.0 and IEEE 802.3 10Base-T and 10Base-FL standards and is fitted with ST connectors, fiber-optic extension cables, and electric cables for Ethernet communication should be provided by customer.

When electric cables are used for Ethernet communication Electric cables for Ethernet communication should be provided by customer.

#### ● Additional Ethernet fiber-optic cable

Material and connector: Silica glass fiber with ST connectors

Mode: Multi-mode GI

Number of cores: 2

Core/Clad diameters: 50/125  $\mu$ m

Applicable wavelength: 850 nm

Length: 1000 m or less in total including an NR895 fiber-optic cable

#### ● Specifications of electric cable for Ethernet communication

Type: 10Base-T, 8-core shielded, straight connection, RJ-45 connectors

Note that when an NR895 fiber-optic cable for Ethernet communication is not used, use an Ethernet crossover cable. If you use a hub, consult Yokogawa.

Length: 3 to 40 m

Finished outside diameter: 5.0 to 7.4 mm

### Specification Sheets for inquiry of NR800 series (1/2)

Thank you for your inquiry. Please fill it customer's requests in order to make a quotation.

Tick all which apply.

#### 1. Scope of Quotation

Essential: Analyzer Measurement cell/probe, Fiber-optic, Software, User's manual (1 copy)

Optional: Document ( Specification for approval \_\_\_\_copy  Test certificate \_\_\_\_copy)

- Factory acceptance test
- Calibration Model implementation by Yokogawa
- On-site hands-on training of Calibration model implementation

#### 2. General

User's name: \_\_\_\_\_

Purpose :  Control  Monitor / alarm  Others

Plant name: \_\_\_\_\_

Document:  English  Japanese

#### 3. Specifications

Number of measuring channel:  1 ch  2 ch  3 ch  4 ch  Possibility of the channel expansion

Analogue output:  Need ( \_\_ points)  Not need

Communication:  Need  Not need

Measurement cell / probe: No.1 ch ( cell  probe) No.2 ch ( cell  probe)

No.3 ch ( cell  probe) No.4 ch ( cell  probe)

Length of fiber-optics: No.1 ch (Laying distance: \_\_\_\_ m) No.2 ch (Laying distance: \_\_\_\_ m)

No.3 ch (Laying distance: \_\_\_\_ m) No.4 ch (Laying distance: \_\_\_\_ m)

#### 4. Installation Condition

Analyzer:  Indoors  Outdoors  explosion-proof  non-ex-proof  Toxic / Corrosive ambiente

Restricted installation area ( \_\_\_\_ m x \_\_\_\_ m)

Measurement cell / probe:  Indoors  Outdoors  Toxic / Corrosive ambiente

#### 5. Utilities

Power supply: \_\_\_\_\_ V AC, \_\_\_\_\_ Hz

Instrument air:  (Pressure \_\_\_\_ MPa)  None

Note: Clear and dry air is required for purging explosion-proof type analyzer. See section 3.2.

#### 6. Sample condition

Please fill in next page.

#### 7. Special note

Please fill out other notes.

---



---



---

## Specification Sheets for inquiry of NR800 series (2/2)

### Sample composition / Measuring Constituent List

Please fill out all sample constituent including non-measuring constituent.

**No.1 ch Sample name:** \_\_\_\_\_  
 Sample temperature: \_\_\_\_\_ to \_\_\_\_\_ °C, normal \_\_\_\_\_ °C  
 Sample pressure: \_\_\_\_\_ to \_\_\_\_\_ MPa, normal \_\_\_\_\_ MPa  
 Babble / slurry:  Bubble  Slurry  Others ( \_\_\_\_\_ )

	Tick for measuring constituent	Constituent Fill out all constituent	Changing / measuring range	Normal	Unit
1			to		
2			to		
3			to		
4			to		
5			to		
6			to		
7			to		
8			to		
9			to		
10			to		

**No.2 ch Sample name:** \_\_\_\_\_  
 Sample temperature: \_\_\_\_\_ to \_\_\_\_\_ °C, normal \_\_\_\_\_ °C  
 Sample pressure: \_\_\_\_\_ to \_\_\_\_\_ MPa, normal \_\_\_\_\_ MPa  
 Babble / slurry:  Bubble  Slurry  Others ( \_\_\_\_\_ )

	Tick for measuring constituent	Constituent Fill out all constituent	Changing / measuring range	Normal	Unit
1			to		
2			to		
3			to		
4			to		
5			to		
6			to		
7			to		
8			to		
9			to		
10			to		

**No.3 ch Sample name:** \_\_\_\_\_  
 Sample temperature: \_\_\_\_\_ to \_\_\_\_\_ °C, normal \_\_\_\_\_ °C  
 Sample pressure: \_\_\_\_\_ to \_\_\_\_\_ MPa, normal \_\_\_\_\_ MPa  
 Babble / slurry:  Bubble  Slurry  Others ( \_\_\_\_\_ )

	Tick for measuring constituent	Constituent Fill out all constituent	Changing / measuring range	Normal	Unit
1			to		
2			to		
3			to		
4			to		
5			to		
6			to		
7			to		
8			to		
9			to		
10			to		

**No.4 ch Sample name:** \_\_\_\_\_  
 Sample temperature: \_\_\_\_\_ to \_\_\_\_\_ °C, normal \_\_\_\_\_ °C  
 Sample pressure: \_\_\_\_\_ to \_\_\_\_\_ MPa, normal \_\_\_\_\_ MPa  
 Babble / slurry:  Bubble  Slurry  Others ( \_\_\_\_\_ )

	Tick for measuring constituent	Constituent Fill out all constituent	Changing / measuring range	Normal	Unit
1			to		
2			to		
3			to		
4			to		
5			to		
6			to		
7			to		
8			to		
9			to		
10			to		