**User's
Manual**

**Model PH8ERP
KCl Refillable type pH Sensor**

IM 12B7K1-02E

vigilantplant.®

◆ INTRODUCTION

This manual covers the PH8ERP KCI Refillable type pH Sensor.

Other related items are described in the following manuals.

Model	Title	IM No.
PH8HG	Guide-pipe Holder	IM 12B7M2-01E
PH8HF, PH8HFF	Flow-Through Type Holder	IM 12B07N01-01E
PH8HS, PH8HSF	Submersion Type Holder	IM 12B07M01-01E
HH350G	Well Bucket Type Holder	IM 19H1B1-01E
PB350G	Float Type Holder	IM 19H1E1-01E
PB360G	Vertical Type Float Holder	IM 19H1E2-01E
PH400G	pH Converter	IM 12B7C1-02E
PH450G	pH/ORP Converter	IM 12B07C05-01E
PH202S, S	pH/ORP Transmitter	IM 12B07D02-01E
PH202SJ	TIIS Intrinsic safe pH/ORP Transmitter	IM 12B07D02-11E
FLXA21	2-Wire Liquid Analyzer	IM 12A01A02-01E
PH100	Panel Mount pH Converter	IM 12B11A01-01E
WTB10-PH□	Terminal Box	IM 19D01B01-01E
PH8TBG	Terminal Box	IM 12B07W01-01E
PH8AX	Accessories for pH Meter	IM 12B07W03-01E

◆ For the safe use of this equipment

■ Safety, Protection, and Modification of the Product

- In order to protect the system controlled by the product and the product itself and ensure safe operation, observe the safety precautions described in this user's manual. We assume no liability for safety if users fail to observe these instructions when operating the product.
- If this instrument is used in a manner not specified in this user's manual, the protection provided by this instrument may be impaired.
- Be sure to use the spare parts approved by Yokogawa Electric Corporation (hereafter simply referred to as YOKOGAWA) when replacing parts or consumables.
- Modification of the product is strictly prohibited.
- The following symbols are used in the product and user's manual to indicate that there are precautions for safety:

■ Notes on Handling User's Manuals

- Please hand over the user's manuals to your end users so that they can keep the user's manuals on hand for convenient reference.
- Please read the information thoroughly before using the product.
- The purpose of these user's manuals is not to warrant that the product is well suited to any particular purpose but rather to describe the functional details of the product.
- No part of the user's manuals may be transferred or reproduced without prior written consent from YOKOGAWA.
- YOKOGAWA reserves the right to make improvements in the user's manuals and product at any time, without notice or obligation.
- If you have any questions, or you find mistakes or omissions in the user's manuals, please contact our sales representative or your local distributor.

■ Warning and Disclaimer

The product is provided on an "as is" basis. YOKOGAWA shall have neither liability nor responsibility to any person or entity with respect to any direct or indirect loss or damage arising from using the product or any defect of the product that YOKOGAWA can not predict in advance.

■ Symbol Marks

Throughout this user's manual, you will find several different types of symbols are used to identify different sections of text. This section describes these icons.



WARNING

Indicates a potentially hazardous situation which, if not avoided, could result in death or serious injury.



CAUTION

Indicates a potentially hazardous situation which, if not avoided, may result in minor or moderate injury. It may also be used to alert against unsafe practices.



IMPORTANT

Indicates that operating the hardware or software in this manner may damage it or lead to system failure.



NOTE

Draws attention to information essential for understanding the operation and features.



Tip

This symbol gives information that complements the current topic.



SEE ALSO

This symbol identifies a source to be referred to.

◆ After-sales Warranty

- Do not modify the product.

- During the warranty period, for repair under warranty consult the local sales representative or service office. Yokogawa will replace or repair any damaged parts. Before consulting for repair under warranty, provide us with the model name and serial number and a description of the problem. Any diagrams or data explaining the problem would also be appreciated.
 - If we replace the product with a new one, we won't provide you with a repair report.
 - Yokogawa warrants the product for the period stated in the pre-purchase quotation. Yokogawa shall conduct defined warranty service based on its standard. When the customer site is located outside of the service area, a fee for dispatching the maintenance engineer will be charged to the customer.

- In the following cases, customer will be charged repair fee regardless of warranty period.
 - Failure of components which are out of scope of warranty stated in instruction manual.
 - Failure caused by usage of software, hardware or auxiliary equipment, which Yokogawa Electric did not supply.
 - Failure due to improper or insufficient maintenance by user.
 - Failure due to modification, misuse or outside-of-specifications operation which Yokogawa does not authorize.
 - Failure due to power supply (voltage, frequency) being outside specifications or abnormal.
 - Failure caused by any usage out of scope of recommended usage.
 - Any damage from fire, earthquake, storms and floods, lightning, disturbances, riots, warfare, radiation and other natural changes.

- Yokogawa does not warrant conformance with the specific application at the user site. Yokogawa will not bear direct/indirect responsibility for damage due to a specific application.

- Yokogawa Electric will not bear responsibility when the user configures the product into systems or resells the product.

- Maintenance service and supplying repair parts will be covered for five years after the production ends. For repair for this product, please contact the nearest sales office described in this instruction manual.

Model PH8ERP KCI Refillable type pH Sensor

IM 12B7K1-02E 6th Edition

CONTENTS

- ◆ INTRODUCTIONi
- ◆ For the safe use of this equipmentii
- ◆ After-sales Warranty.....iv
- 1. Specification 1-1
 - 1.1 Standard Specifications..... 1-1
 - 1.2 Model and Suffix codes..... 1-2
 - 1.3 External Dimensions 1-4
- 2. Installation..... 2-1
 - 2.1 Preparation for Installation 2-1
 - 2.1.1 Unpacking and Inspection 2-1
 - 2.1.2 Installing Holder 2-1
 - 2.1.3 Installing Associated Instruments 2-1
 - 2.2 Requirements for mounting the pH sensor 2-2
 - 2.2.1 In case of installing the PH8HG Guide-pipe Holder 2-2
 - 2.2.2 Installing Sensor in PH8HS Submersion Holder 2-3
 - 2.2.3 Installing Sensor in PH8HF Flow-through Holder..... 2-6
 - 2.3 pH Sensor Cable Wiring Procedure..... 2-7
 - 2.3.1 Connecting Sensor Cable to Terminal Box..... 2-7
 - 2.3.2 Connecting Sensor Cable to Two-wire pH Transmitter 2-9
 - 2.3.3 Connecting Sensor Cable to Four-wire pH Converter..... 2-10
- 3. Maintenance on operation..... 3-1
 - 3.1 Operation and Periodic Maintenance 3-1
 - 3.1.1 Advance Preparation 3-1
 - 3.1.2 Calibrating pH Sensor Using Buffer Solutions..... 3-1
 - 3.1.3 Cleaning Glass Electrode and Liquid Junction 3-1
 - 3.1.4 Refilling Sensor with KCI Solution 3-2
 - 3.2 Replacing Consumable Parts..... 3-3
 - 3.2.1 Replacing Glass Electrode 3-3
 - 3.2.2 Replacing Liquid Junction..... 3-4
 - 3.2.3 Replacing O-rings for Glass Electrode 3-4
- Customer Maintenance Parts List..... CMPL 12B07K01-02E
- Revision Informationi

1. Specification

The Model PH8ERP KCl Refillable pH Sensor features maintainability which involves no KCl solution coming out of the liquid junction.

This sensor can be mounted on either an PH8HF flow-through holder or an PH8HS submersion holder. The sensor can be submerged up to a maximum of 3 meters.

1.1 Standard Specifications

Measurement: Hydrogen ion concentration (pH) of a solution

Measurement principle: Glass electrode method

Measuring range: pH 2 to 12

Installation: Mounting in PH8HS submersion holder

Mounting in PH8HG guide-pipe holder

Mounting in PH8HF flow-through holder

Note: If any of the following solutions are measured, install the sensor either in a flow-through or submersion holder.

- A strong acid solution is to be measured (e.g., aqua regia, chromic acid, hypochlorous acid or perchloric acid, etc.).
- The solution contains corrosive gases (e.g., ammomia, chlorine, hydrogen sulfide, etc).
- The solution contains a small percentage of organic solvent or oil.

Solution temperature : -5 to 80°C (refer to Table 1)

Table 1. Process Temperature Range

Holder Type	Holder Material	Solution pH Range	Cleaner	Solution Temperature (°C)
Guide-pipe (PH8HG)	PVC	2 to 12	None	-5 to 50
	PP		None	-5 to 80
Submersion (PH8HS) Flow-through (PH8HF)	PP, SUS		None Provided	-5 to 80
Well Bucket (HH350G)	SUS		None Provided	-5 to 80
Float (PB350G, PB360G)	PP, SUS		None	-5 to 80

PVC: Hard PVC
PP: Polypropylene
SUS: SUS 316

Temperature detection element : Pt1000

Solution pressure : under atmospheric pressure to 50 kPa, when using a holder, refer to Table 2.

Table 2. Process Pressure Range

Holder	Process Pressure Range
Submersion	Atmospheric pressure (Submersion depth: Max. 3 m)
Guide-pipe Suspension Float	Atmospheric pressure (Submersion depth: Max.3 m)
Flow-through	Atmospheric pressure to 50 kPa

(Note 1) For flow-through types, refer also to the solution temperature and pressure diagram of Holder IM.

Operating solution depth :	3 m water pressure (max.) under atmospheric pressure
Solution flow velocity :	2 m/s max.
Solution flow rate :	3 to 11 l/min (when the sensor is installed in a flow-through type holder).
Solution conductivity :	50 µS/cm or higher
Wetted part materials:	
Body;	Ryton (PPS resin), glass, titanium or Hastelloy C, ceramics, fluorocarbon rubber or Daielperfrow rubber
Cable;	Chlorinated polyethylene rubber (Cable sheath)
Weight:	Approx. 0.4 kg (Body)
Output Response:	Response time (for 90% response): 10 seconds maximum (when the sensor, stabilized at 20°C, measures a solution at 20°C).

CAUTION

Select the material of wetted parts with careful consideration of process characteristics. Inappropriate selection may cause leakage of process fluids, which greatly affects facilities. Considerable care must be taken particularly in the case of strongly corrosive process fluid such as hydrochloric acid, sulfuric acid, hydrogen sulfide, and sodium hypochlorite. If you have any questions about the wetted part construction of the product, be sure to contact Yokogawa.

1.2 Model and Suffix codes

● pH Sensor

Model	Suffix Code	Option Code	Description
PH8ERP	KCl Refillable Type pH Sensor
Cable Length	-03 -05 -07 -10 -15 -20	3m 5m 7m 10m 15m 20m
Solution Ground Tip	-TN -HC	Titanium Hastelloy C
—	-N	Always -N
pH Measuring System	-T -E -F -B -G	For PH200/PH400 (*1) For PH202/FLXA21 (*2) For FLXA21 (*6) For PH100 (*3) For PH450G,PH202/TB (*5)
Style	*A	Style A
Option	O-ring	/PF	Daielperfrow (*4)

*1: Mark band is shown by mark and fork terminals are used.

*2: Mark band is shown by numeral and pin terminals are used.

*3: The tag which indicated the color, the sign, and the number is attached to the cable of a sensor.

*4: Choose Daielperfrow when this is used in organic solvent, high alkali or high temperature solution.

*5: Mark band is shown by numeral and M3 ring terminals are used.

When terminal box is used, select WTB10-PH3.

*6: Mark band is shown by numeral and M4 ring terminals are used.

When terminal box is used, select WTB10-PH5.

● Accessories

Model	Suffix Code	Option Code	Description
PH8AX	Accessories for pH meter (*1)
Calibration Reagents	-L -P	Two bottles, each containing 250ml solution (pH7 and pH4) 24 bags, each bag containing powder for 500ml solution (pH7 X 12 bags and pH4 X 12 bags) and two 500ml polyethylene bottles.
Style	*A	Style A
Option		/STD /TMP	Sensor stand (with mounting bracket for 50A 2-inch pipe) Thermometer (0 to 100 °C)

(*1): Including the following:
Two 200 ml polyethylene cups
One cleaning bottle

● Consumables

Part Name		Part Number	Remarks
Glass electrode	General purpose	K9142TN	One
		K9319NA	One for /PF option
Junction	General purpose	K9142TH	One
		K9319QA	One for /PF option
	Teflon	K9142HW	One for /TF option
		K9319QB	One for /TF /PF option
Buffer solution for calibration (pH 4)		K9084LL	Six 250 ml polyethylene bottles
Buffer solution for calibration (pH 7)		K9084LM	Six 250 ml polyethylene bottles
Buffer solution for calibration (pH 9)		K9084LN	Six 250 ml polyethylene bottles
Powder for buffer solution (pH 4)		K9020XA	12 bags, each for preparation of 500 ml
Powder for buffer solution (pH 7)		K9020XB	12 bags, each for preparation of 500 ml
Powder for buffer solution (pH 9)		K9020XC	12 bags, each for preparation of 500 ml
KCl powder (for PH8ERP)		K9142UT	2 bags, 1 bottle of 3.3 mol/l KCl, 1 syringe

(Note) The pH value of the calibrating buffer solution may vary depending on storage conditions.
Prepare a new solution from powder for accurate instrument calibration

1.3 External Dimensions

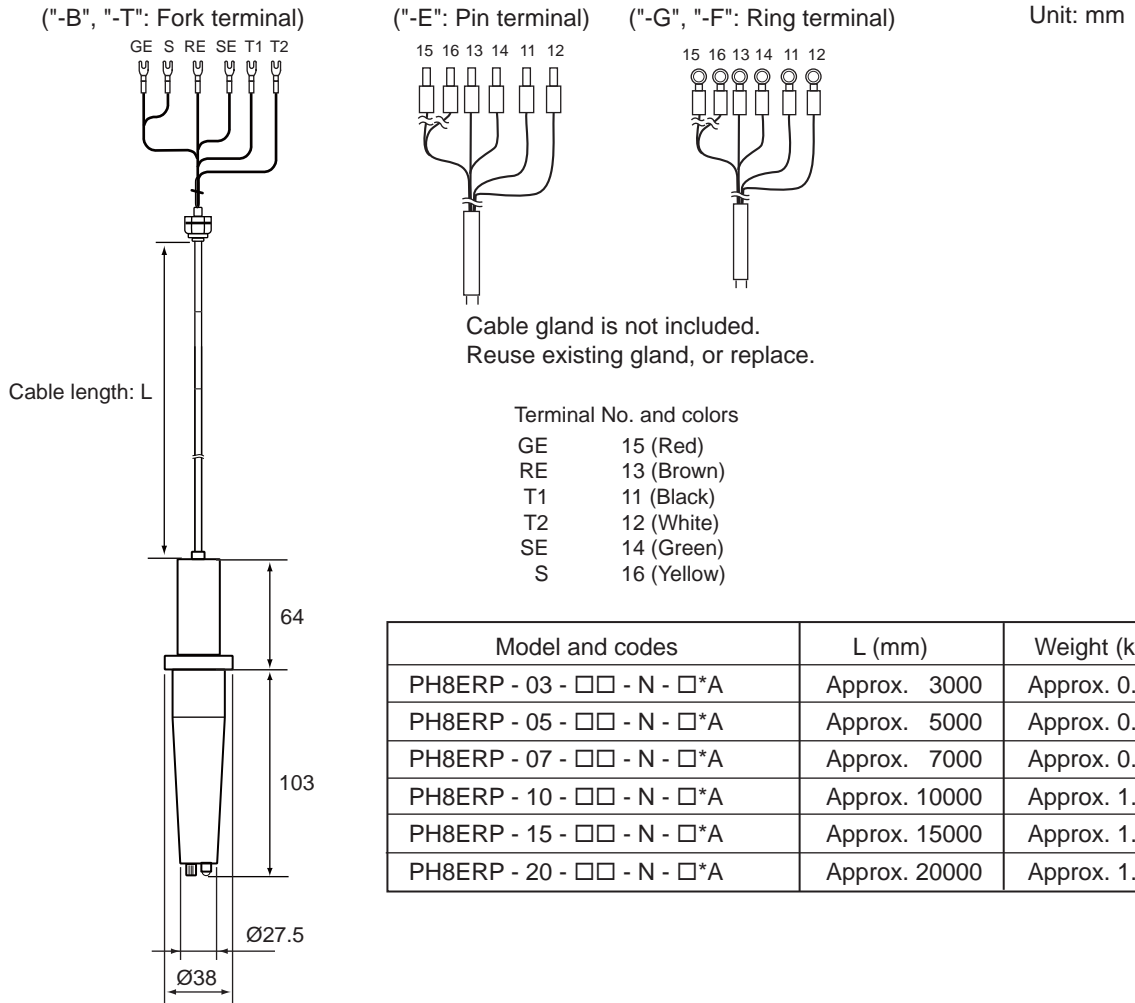

Figure 1.1 PH8ERP Refillable type pH Sensor

F1.1.ai

2. Installation

2.1 Preparation for Installation

2.1.1 Unpacking and Inspection

The Model PH8ERP pH sensor is packed at the factory to prevent damage during transportation. Upon receipt of the sensor, unpack the shipping container and then visually inspect it for damage. Also check the instrument nameplate on the sensor cable to make sure that you received the correct sensor.



NOTE

Do not attempt to remove the liquid junction (see Figure 2.2 below), Otherwise, the sensor internal solution will leak out. Do not let the liquid junction and glass electrode dry out. To prevent this, place the protective cap covering the top of the sensor in its original position until the sensor is installed.

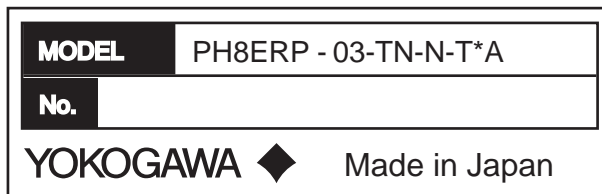

F2.1.ai

Figure 2.1 An Example of Model Number Entering to Nameplate

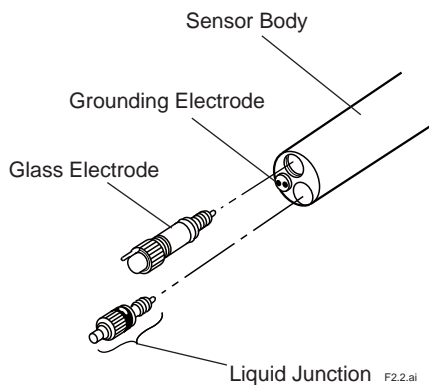

F2.2.ai

Figure 2.2 Names of PH8ERP pH Sensor Components

2.1.2 Installing Holder

Usually, the pH sensor is suspended in a guide pipe or installed in a flow-through or submersion holder. First install the holder.

2.1.3 Installing Associated Instruments

Make sure that the associated instrument (a pH transmitter/converter or a junction terminal box) to which the pH sensor cable is connected has already been installed.

2.2 Requirements for mounting the pH sensor

2.2.1 In case of installing the PH8HG Guide-pipe Holder

To install the sensor in the guide pipe, proceed as follows:

- (1) Connect the sensor cable to the associated instrument correctly by referring to Section 2.3 provided later.
- (2) Attach the "stopper" supplied with the guide pipe to the sensor cable.

Fix the sensor cable so that the sensor tip projects 20 to 30 mm out from the pipe end when the pH sensor is suspended in the guide pipe as shown in Figure 2.3.



NOTE

If the sensor tip does not project out from the pipe end, the measured value may not respond promptly to the pH variations of the measured solution. This may cause problems for pH measurement and control. On the other hand, if the sensor tip projects too far from the pipe end, the force on the sensor may damage the sensor cable from scraping it against the pipe.

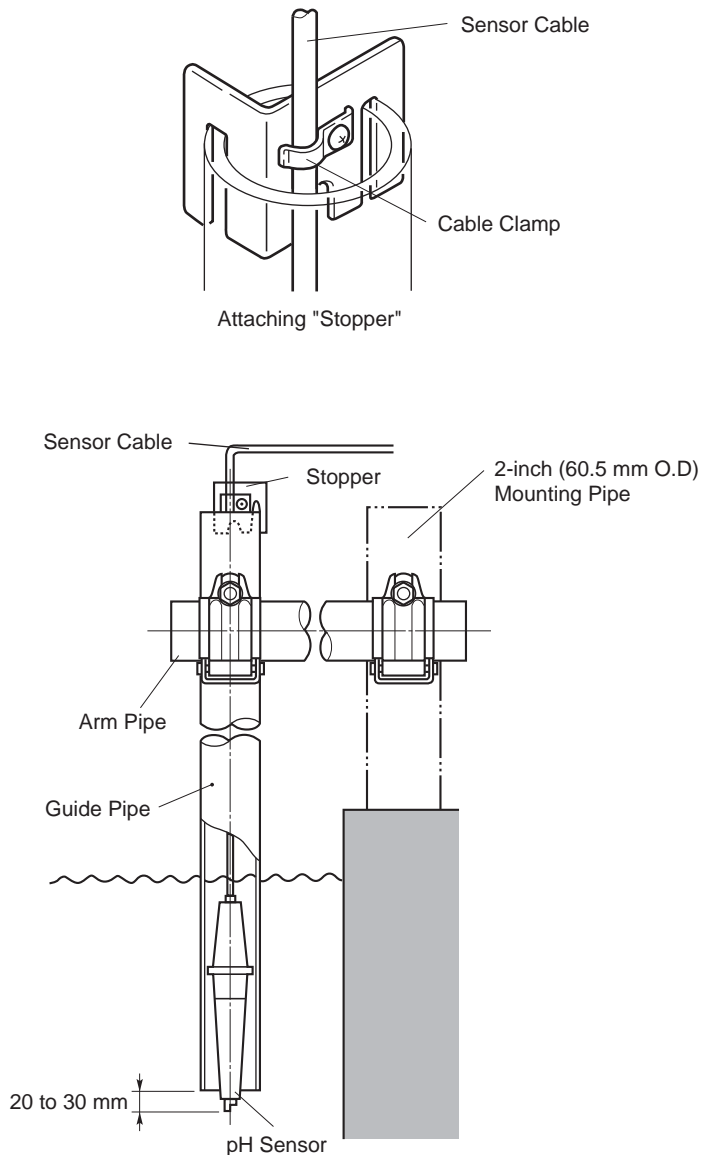

Figure 2.3 Mounting Sensor in Guide Pipe

2.2.2 Installing Sensor in PH8HS Submersion Holder

To install the sensor in the submersion holder, proceed as follows:

- (1) Pass the sensor cable through the sensor holder. If the submersion holder remains installed, remove the sensor holder in any case.

For a pipe-mounting submersion holder without a cleaner, loosen the sensor holder nut to remove the holder.

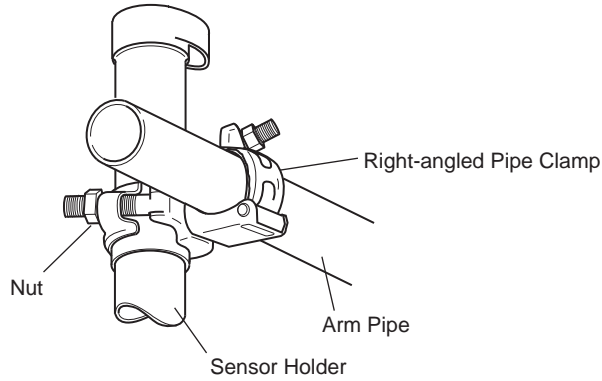

Removal of Sensor Holder (Arm Pipe used with option /MS1 or /MS2)

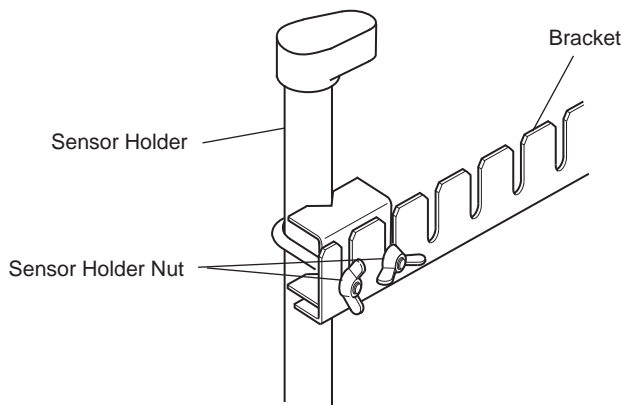

F2.4.ai

Removal of Sensor Holder (Stainless Bracket used with option /MS3 or /MS4)

Figure 2.4 Removal of Sensor Holder (for Pipe Mounting Sensor without Cleaner)

For a flange mounting submersion holder without a cleaner, remove the sensor holder by loosening the two bolts securing the sensor holder to the flange (see Figure 2.5).

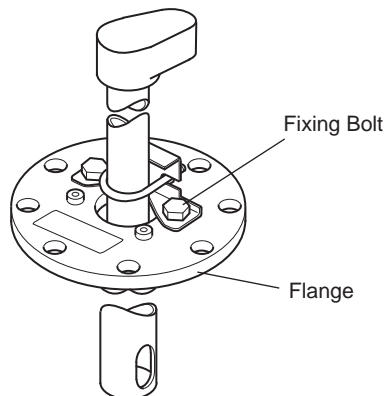

F2.5.ai

Figure 2.5 Removal of Sensor Holder (for Flange Mounting Sensor without Cleaners)

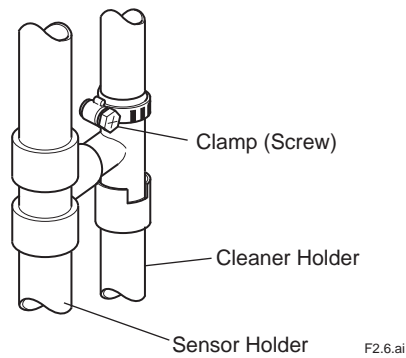

Figure 2.6 Removal of Sensor Holder (with Cleaner)

To install the sensor cable in the sensor holder, first remove the protector screwed onto the sensor holder end and then remove the protective foam piece (for shipping; thus, it is not necessary after the sensor is installed in the holder). Pass the sensor cable through the O-ring then attach the O-ring to the sensor flange (see Figure 2.7).

When passing the sensor cable through the holder, if the inside of the holder is dirty or wet, take special care to keep the cable dry by covering the sensor cable end with a polyethylene bag or the like.



SEE ALSO

For details to install the sensor onto a holder, refer to relevant IMs.

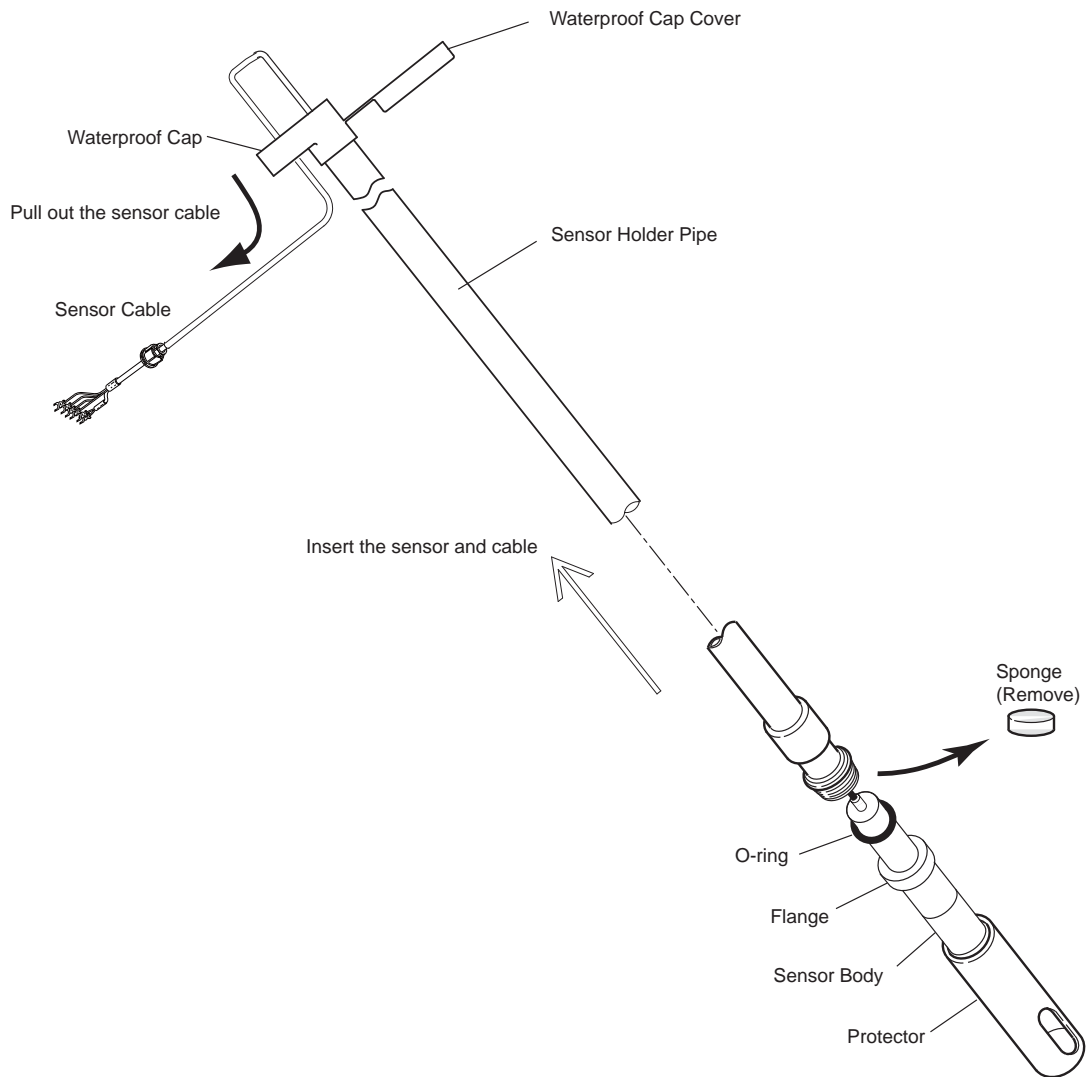

Figure 2.7 Installing the Sensor Cable

- (2) Connect the sensor cable to the associated instrument correctly by referring to Section 2.3.
- (3) Screw the protector to fix the sensor to the holder. In this case, remove the protective cap and secure the protector so that the flange of the sensor compresses the O-ring firmly. about the installation method.

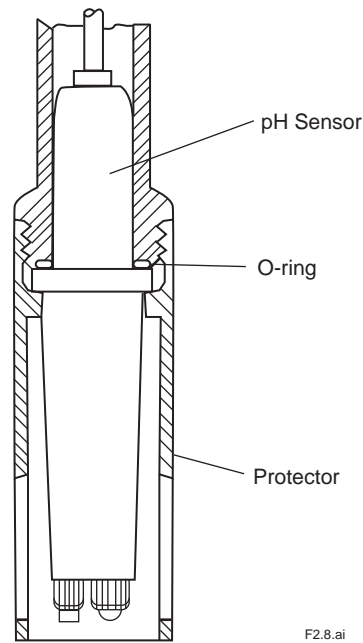

Figure 2.8 Installing Sensor in Submersion Holder

- (4) Close the waterproof cap, and attach the holder to the arm pipe, flange or cleaner holder completely.

2.2.3 Installing Sensor in PH8HF Flow-through Holder

To install the sensor in a flow-through holder, proceed as follows:

- (1) Connect the sensor cable to the associated instrument. First, remove the sensor fixing nut and pass the sensor cable through the nut.

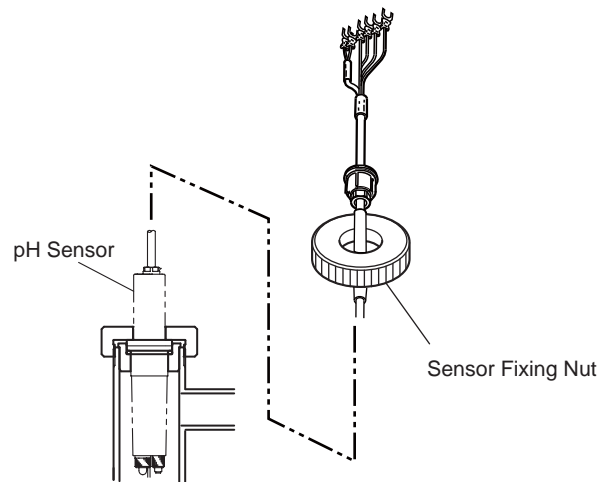

Figure 2.9 Preparation for Sensor Cable Connection

Properly connect the sensor cable by referring to Section 2.3.

- (2) Connect the pH sensor to its holder. Remove the protective cap from the sensor. Also remove the protective foam piece (for shipping - this is not necessary after installing the sensor) from the holder. Be sure that the liquid junction and glass electrode are mounted properly. Insert the sensor tip into the holder and tighten the sensor fixing nut securely (see Figure 2.10).

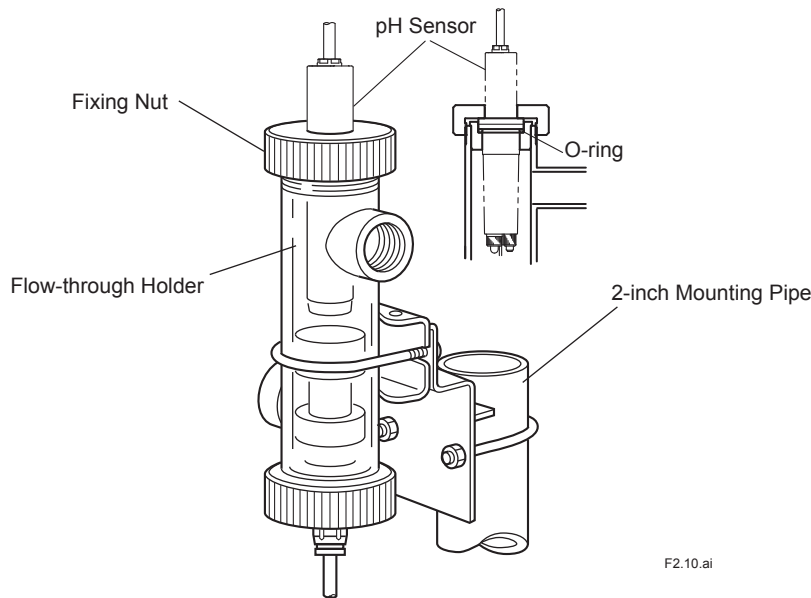

Figure 2.10 Installing Sensor in Flow-through Holder

2.3 pH Sensor Cable Wiring Procedure

2.3.1 Connecting Sensor Cable to Terminal Box

- (1) Open the cable inlet hole in terminal box using the supplied punch tool. The location of the cable inlet hole is shown by the circle-shaped groove under the case. The end of the supplied punch tool is put in the center of this circle and it is tapped with appropriate force. You can punch out the hole along the groove.

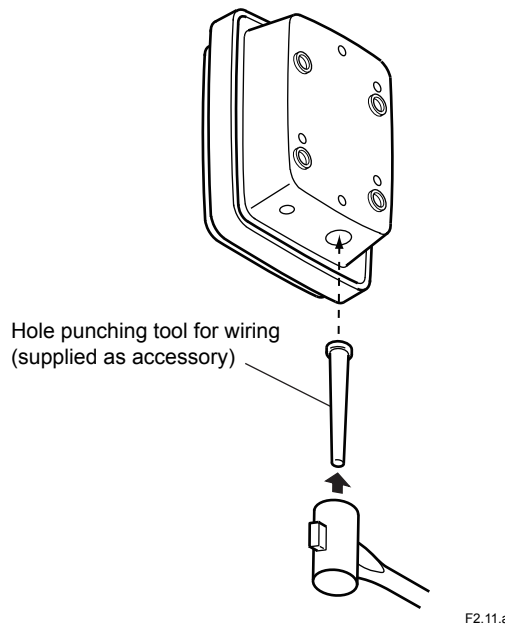

Figure 2.11 How to punch out the wiring hole

- (2) Loosen two screws which are at front of terminal box and detach the cover.
 - (3) After detaching the nut from the cable gland of sensor cable, pull the cable into the terminal box from sensor cable inlet hole.
- Connect the sensor cable to the terminals.

After passing the cable through the nut, check the symbol on each core wire, then connect each core wire to the corresponding terminal.

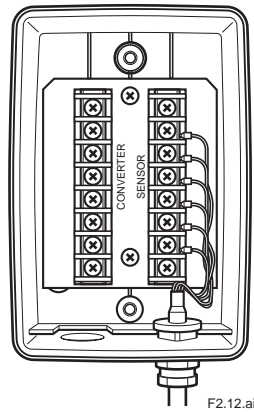

Figure 2.12 Connecting Sensor Cable (In case of the PH8TBG)

- (4) Mount the cable gland in the cable inlet hole.

Put the nut in place, and screw it onto the main body sufficiently. At this time, loosen the cap so that the cable is not twisted. After fixing the main body, tighten the cap to keep moisture out of the equipment. However if the cap is screwed up too tight, the cable will be damaged.

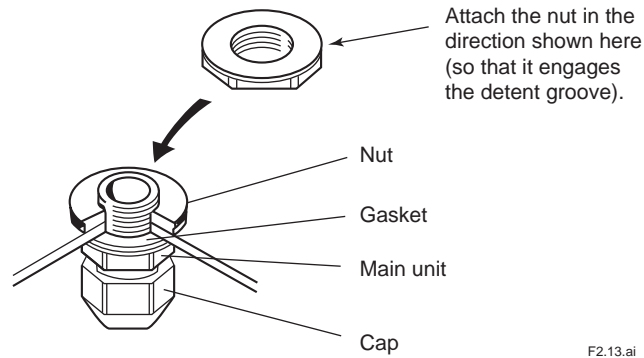

Figure 2.13 Cable Gland

- (5) After completing the cable connections, replace the box cover securely, thus preventing moisture from getting into the case.

2.3.2 Connecting Sensor Cable to Two-wire pH Transmitter

To connect the sensor cable to the two-wire pH transmitter, proceed as follows:

- (1) Loosen the four screws that tighten the transmitter cover. Then remove the transmitter cover.
- (2) Connect the sensor cables to the relevant terminals of the transmitter:

First, remove the nut from the cable gland. Insert the cable into the right opening for the wiring. Then pass the cable through the nut, Connect the individual cable conductors to the relevant terminals correctly by referring to the markings on the individual conductors.

For details, refer to relevant transmitter IMs.

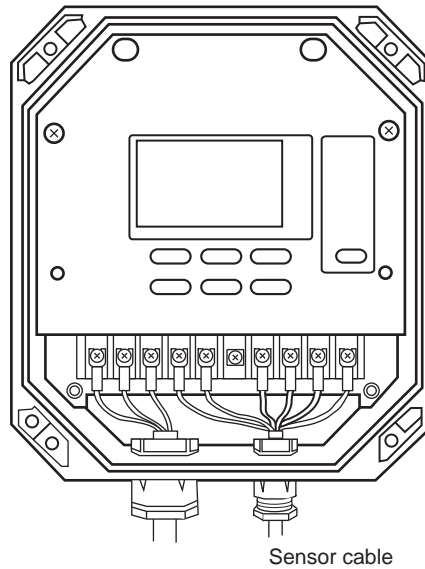

Figure 2.14 Connecting Sensor Cable to Two-wire pH Transmitter

- (3) Install the cable gland in the wiring hole as follows:

Pass the tip of the cable gland into the opening and completely tighten the gland with the nut inside the case.

After tightening the gland, secure the cap properly to prevent moisture from getting into the case.

Caution: Do not overly tighten the cap. Otherwise, the cable may be damaged.

- (4) After completing the cable connections, replace the transmitter cover securely, thus preventing moisture from getting into the case.

2.3.3 Connecting Sensor Cable to Four-wire pH Converter

To connect the sensor cable to a Four-wire pH converter, proceed as follows:

- (1) Loosen the four screws that tighten the converter cover. Then remove the converter cover.
- (2) Connect the sensor cables to the relevant terminals of the converter:

First, remove the nut from the cable gland. Insert the cable into the right opening for the wiring. Then pass the cable through the nut, Connect the individual cable conductors to the relevant terminals correctly by referring to the markings on the individual conductors.

For details, refer to relevant converter IMs

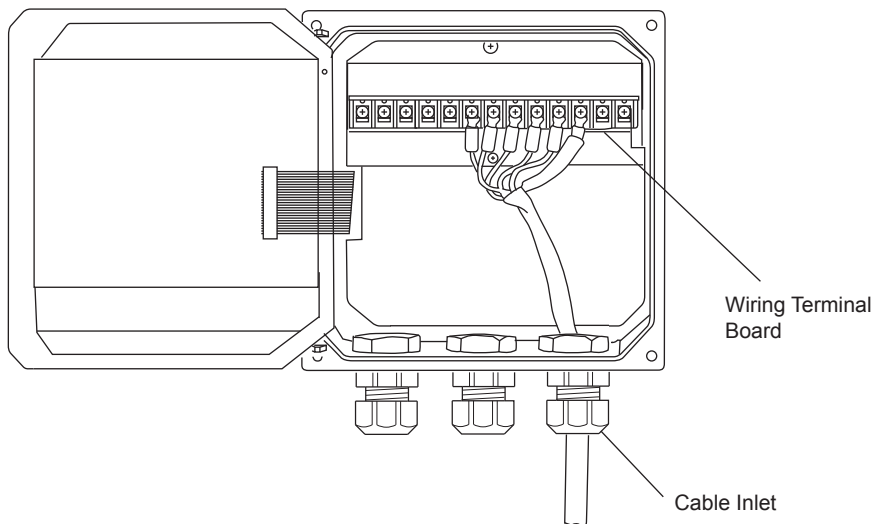

Figure 2.15 Connecting Sensor Cable to Four-wire pH Converter

- (3) Install the cable gland in the wiring hole as follows:

Pass the tip of the cable gland into the opening and completely tighten the gland with the nut inside the case.

After tightening the gland, secure the cap properly to prevent moisture from getting into the case.

Caution: Do not overly tighten the cap. Otherwise, the cable may be damaged.

- (4) After completing the cable connections, replace the converter cover securely, thus preventing moisture from getting into the case.

3. Maintenance on operation

3.1 Operation and Periodic Maintenance

3.1.1 Advance Preparation

A glass electrode whose glass membrane has dried out does not provide stable readings until it gets used to the solution. Place in advance the glass electrode either in the pH4 or pH7 buffer solution for more than a half day before calibrating the pH sensor with buffer solutions.

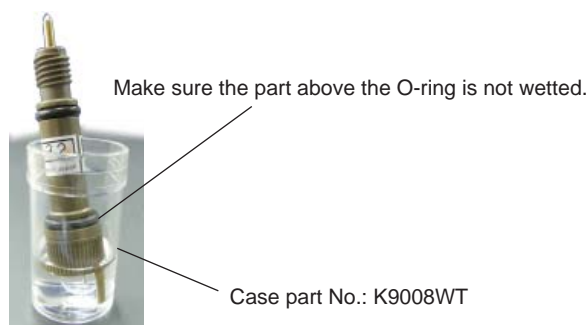

CAUTION

Mounting the glass electrode on the sensor body while the part above the O-ring (on the opposite side of the glass membrane) of the glass electrode is wet may cause insulation deterioration and the like. There is enough solution if the glass membrane is submerged.

Make sure the O-ring is not submerged in the solution. Before mounting the glass electrode on the sensor body, wipe the glass electrode completely with a tissue paper and the like to make sure there are no water droplets on the O-ring and the part above it.

3.1.2 Calibrating pH Sensor Using Buffer Solutions

Calibrate pH sensors with buffer solutions before starting normal operation because the emf of glass electrodes differs somewhat from each other.

The emf of a glass electrode gradually changes due to electrode staining or deterioration.

Therefore, buffer solution calibration must be carried out periodically within a given period of time to keep the measurement errors within the limits specified.

For more detailed information on the calibration procedures, see relevant transmitter/converter IMs.

3.1.3 Cleaning Glass Electrode and Liquid Junction

Staining of a glass electrode or liquid junction can cause measurement errors. Therefore, if the measured solutions tend to stain the electrode, the glass electrode and liquid junction must be cleaned periodically - depending on the degree of staining. If the pH sensor is installed in a holder with a cleaner, the sensor is continuously (for an ultrasonic cleaner) or intermittently (for a jet or brush cleaner) cleaned automatically.

Because of this, sensor cleaning is not usually required. However, if the sensor characteristics are affected by chemical staining, for example, when the sensor is used for pH measurement of a highly alkaline solution, carry out acid washing.

To clean the glass electrode or liquid junction, proceed as follows:

- **Stains due to suspended Solids, Sticky Materials, Microbes or the like**

Using soft tissue paper, wipe the stains off the glass electrode or liquid junction. In addition, clean off remaining stains by rinsing with water.

- **Stains due to Oily Materials**

Wash off stains by submerging in a neutral detergent solution in a beaker, etc, (for from several tens of minutes to several hours depending on the degree of staining).

- **Chemical Stains such as due to Metallic Adsorption**

Place the glass electrode or liquid junction in a diluted hydrochloric acid solution (1 to 2%) for several minutes (acid washing).

3.1.4 Refilling Sensor with KCl Solution

The concentration of the KCl solution in the sensor will begin to drop when the saturated concentration cannot be maintained with the KCl solution from the liquid junction. As the concentration of the KCl solution decreases, so too does this influence the sensor's performance. To avoid this, replenish the KCl solution in the sensor before the concentration starts to decrease.

The time required for maintaining the saturated concentration of a KCl solution in a sensor is greatly influenced by the sensor's operating conditions. For example, as temperature variations in measured solutions are great, or as solution temperatures are high, so too does the amount of KCl solution drained from the liquid junction increase, thereby shortening the period of time for maintaining the saturated concentration.

In addition if the KCl solution in the sensor becomes contaminated from ions in the solution under measurement, this influences the sensor's performance. The degree of contaminated KCl solution greatly depends on the properties of the measured solution.

From the above viewpoint, we cannot precisely determine the replenishment period of KCl solution. Usually, the KCl solution in a sensor should be replenished every six months or once a year.

To replenish the KCl solution in the sensor, proceed as follows:

- (1) Prepare a KCl solution available as an optional kit (part number: K9142UT), If it is not yet available, use instead KCl powder (about 12 g) and pure water (about 50 ml) and a clean pipet (or a 20 ml syringe) to replenish the KCl solution.

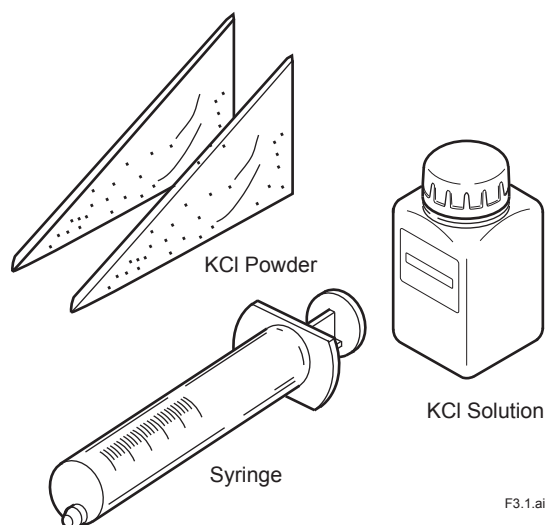

Figure 3.1 KCl Solution Replenishing Kit (Part Number: K9142UT)

- (2) Remove the sensor from its holder. Wipe off dirty areas on the sensor tip.

- (3) Remove the liquid junction from the sensor. Leave the glass electrode mounted securely.
- (4) Drain the KCl solution in the sensor through the liquid junction mounting hole.
- (5) Wash the inside of the sensor, Pour about a 10 ml KCl solution (or pure Water) into the sensor from the liquid junction mounting hole. Shake the sensor and then drain the solution or pure water completely from the sensor.
- (6) Pour about 10 or 12 grams of powder into the sensor, Use a bag of KCl powder when using the optional KCl solution kit, Cut off the tip of the bag and follow Figure 3.2 below. If the KCl powder has hardened, break it up into pieces. Then do the above.

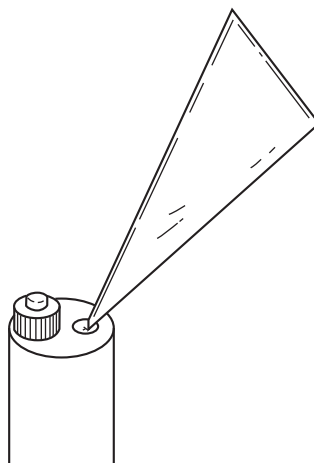

Figure 3.2 Pouring KCl Powder into Sensor

- (7) Pour the KCl solution (or pure water) into the sensor until it overflows through the junction hole. In doing this, do not leave any air pockets in the body.
- (8) Restore the liquid junction removed in Step (3) above to its original position.
Calibrate the sensor using buffer solutions.

3.2 Replacing Consumable Parts

3.2.1 Replacing Glass Electrode

If buffer solution calibration becomes impossible due to deterioration of the glass electrode, replace it with a new one. After the glass electrode is replaced, always carry out a buffer solution calibration.

However, a glass electrode whose glass membrane has dried out does not provide stable readings until some time after immersion in solution. Place the electrode in water according to Section 3.1.1 "Advance Preparation" to stabilize its characteristics before calibrating the pH sensors with buffer solutions.

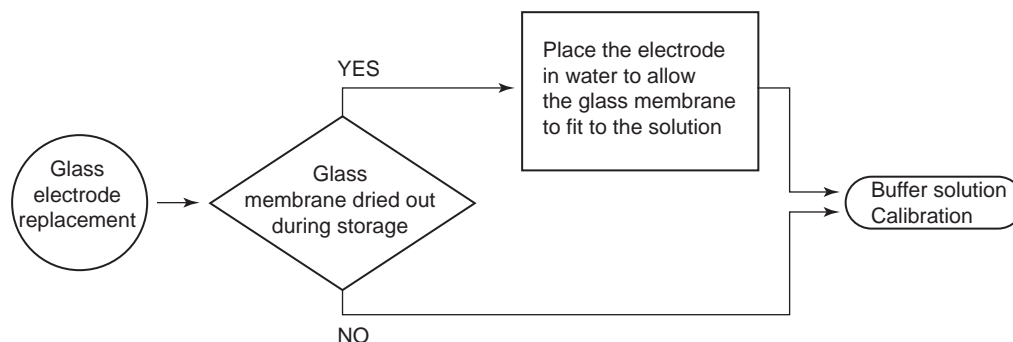

3.2.2 Replacing Liquid Junction

Even after washing the liquid junction, if normal measurement cannot be made, replace the liquid junction.

When replacing the liquid junction, fill the sensor with KCl solution to just before the solution overflows through the liquid junction mounting hole. Use a 3.3 mol KCl solution (a higher concentration of KCl or KCl powder) for this application.

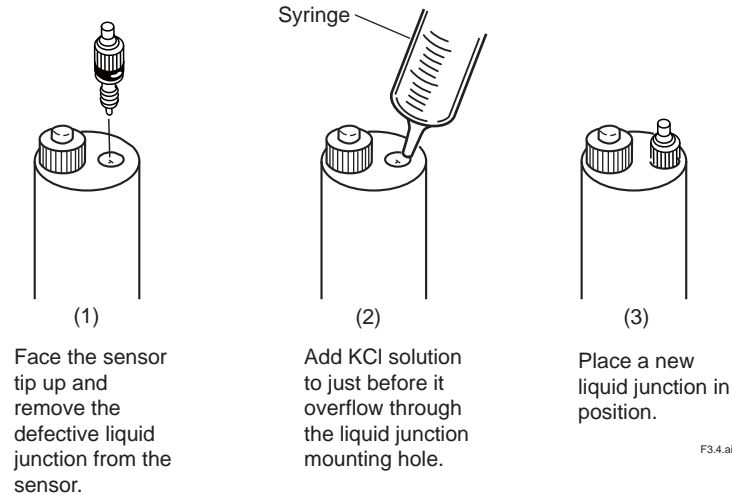

Figure 3.4 Replacing Liquid Junction

3.2.3 Replacing O-rings for Glass Electrode

As the inside of the glass electrode mounting hole must have high insulation resistance, fluorocarbon rubber O-rings - with superior chemical and heat resistance - are used for sealing. Except for special uses, this O-ring does not need individual replacement. If any damage - which might cause problems - is detected in the O-ring, as a rule, replace it along with the glass electrode.

Although the O-ring can be replaced individually if the O-ring deteriorates much faster than the glass electrode, it is recommended that the whole glass electrode be replaced to avoid possible deterioration of the O-ring inside the glass electrode. For individual replacement of the O-ring, use the one recommended by Yokogawa.

When installing the O-ring, wind a slip of paper or tape around the thread part on the glass electrode so as not to scratch the O-ring. Otherwise, such scratches may damage its sealing properties.

For ordering, refer to the Customer Maintenance Parts List (CMPL) at the end of the book to check the appropriate part number of the O-ring.

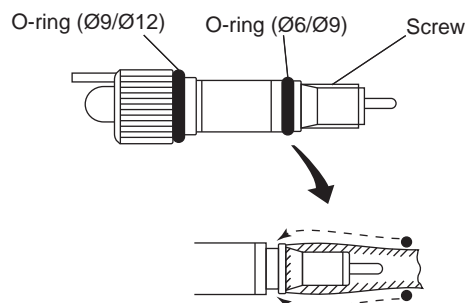

Before installing, wind a slip of paper or tape around the thread part to prevent scratches.

Figure 3.5 Installing the O-ring

Customer Maintenance Parts List

Model PH8ERP KCI Refillable type pH Sensor

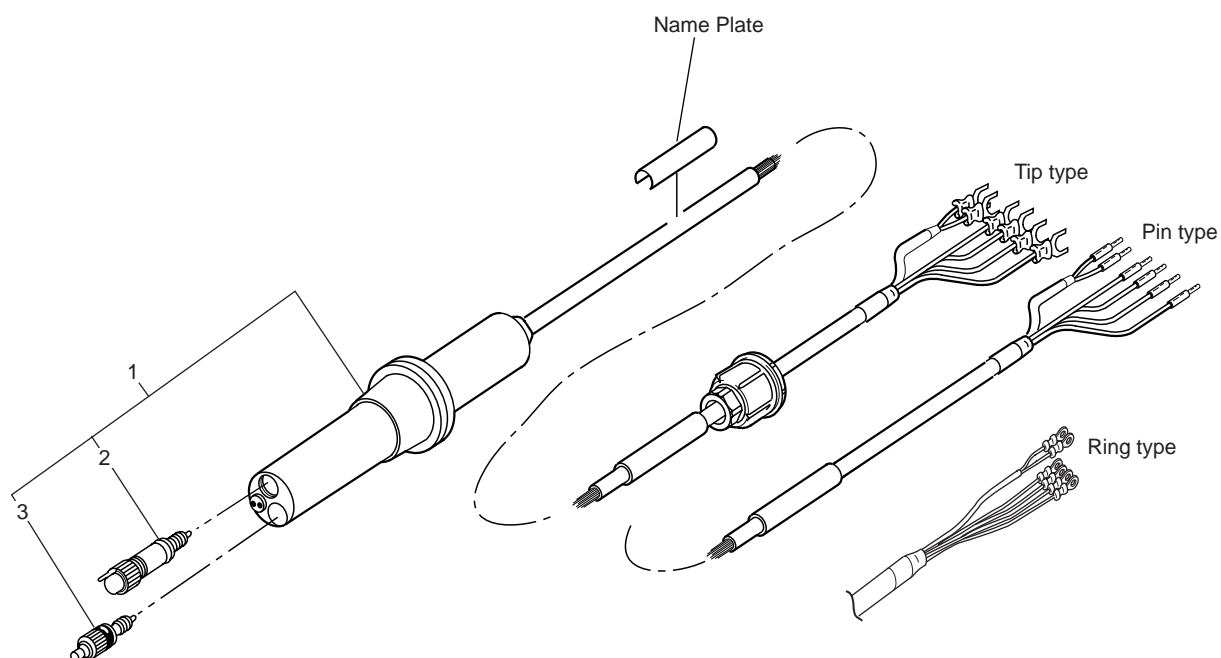

Item	Part No.	Qty	Description
1	Below	1	Body Assembly Model PH8ERP-□□-TN Model PH8ERP-□□-HC
2	Below		Glass Electrode Assembly
	K9142TN	1	for general use
	K9319NA	1	for PH8ERP/PF
-	K9142QR	1	O-Ring, 6 mm ID. × 9 mm OD.
-	K9142QS	1	O-Ring, 9 mm ID. × 12 mm OD.
3	Below		Junction Assembly
	K9142TH	1	for general use
	K9319QA	1	for PH8ERP/PF
-	K9142QR	1	O-Ring, 6 mm ID. × 9 mm OD.

Revision Information

- Title : Model PH8ERP KCl Refillable type pH Sensor
- Manual No. : IM 12B7K1-02E

Jul. 2011/6th Edition Page layout changed by InDesign

P i, Reference manual number of FLXA21 added.
P 1-3, M4 ring terminals for FLXA21 added to MS-code.
P 1-5, M4 ring terminals added to external dimensions.
CMPL 12B05J01-02E revised to 9th edition (Note for 500 ml KCl tank modified).

Mar. 2010/5th Edition

P3-1 to 3-3, Section 3.1.1 has been changed to "Advance Preparation", and section order change as following. "3.1.2 Calibrating pH Sensor Using Buffer Solutions", "3.1.3 Cleaning Glass Electrode and Liquid Junction", "3.1.4 Refilling Sensor with KCl Solution". Some of Section 3.2.1 "Replacing Glass Electrode" modified; P3-4, Illustration of Figure 3.4 and 3.5 replaced to more clearly drawings; CMPL 12B07K01-02E, Revised to 5 th edition because some of parts number corrected.

Apr. 2008/4th Edition

M3 ring terminals added for PH450G, CMPL12B07K01-02E revised to 4th edition.

Jul. 2006/3rd Edition

All over revised

Feb. 1996/2nd Edition

Some error corrected

Dec. 1995/1st Edition

Newly published.

-
- If you want to have more information about Yokogawa products, you can visit Yokogawa's home page at the following web site.
Home page: <http://www.yokogawa.com/an>
-

Thank you for selecting our Model PH8ERP KCI Refillable type pH Sensor.

The User's Manual IM 12B7K1-02E 6th edition supplied with this product has been amended as follows, please make a note in your copy.

Revisions:

- CMPL 12B07K01-02E revised to 6th edition, because some P/N addition of O-ring for /PF option.

Customer Maintenance Parts List

Model PH8ERP KCI Refillable type pH Sensor

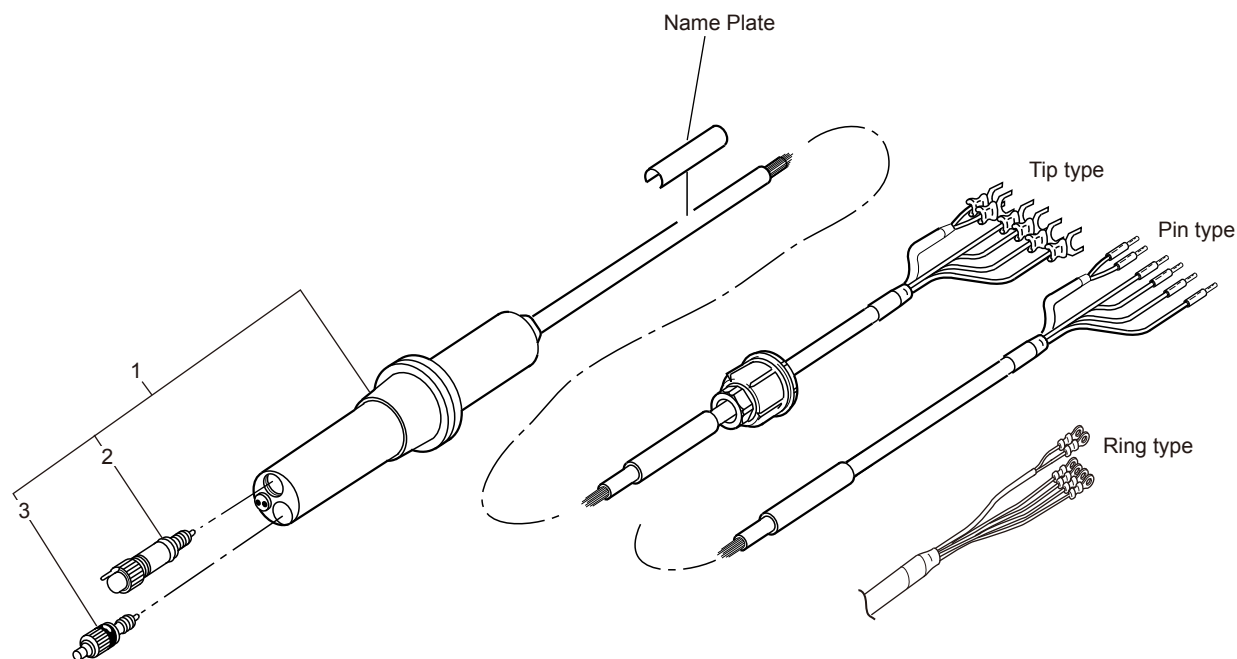

Item	Part No.	Qty	Description
1	Below - -	1	Body Assembly Model PH8ERP-□□-TN Model PH8ERP-□□-HC
2	Below K9142TN K9319NA - Below K9142QR K9142QS K9319RB K9319RC	1 1 1 1 1 1 1 1	Glass Electrode Assembly for general use for PH8ERP/PF O-Ring for general use, 6 mm ID. x 9 mm OD. for general use, 9 mm ID. x 12 mm OD. for PH8ERP/PF, 6 mm ID. x 9 mm OD. for PH8ERP/PF, 9 mm ID. x 12 mm OD.
3	Below K9142TH K9319QA - Below K9142QR K9319RB	1 1 1 1 1 1	Junction Assembly for general use for PH8ERP/PF O-Ring for general use, 6 mm ID. x 9 mm OD. for PH8ERP/PF, 6 mm ID. x 9 mm OD.