

---

**User's  
Manual**

**CONDUCTIVITY METERING SYSTEM  
Model SC210G  
CONDUCTIVITY DETECTOR**

IM 12D08G03-01E

---

**vigilantplant.<sup>®</sup>**



# ◆ Introduction

An EXA SC Series Conductivity Measuring System consists of a SC210G Conductivity Detector, as described in this manual, used in conjunction with an SC202, FLXA21 or SC450G Conductivity Converter.

The SC210G Conductivity Detector may use sensors with cell constant of  $0.05 \text{ cm}^{-1}$ , to measure conductivities of 0 to 200  $\mu\text{S/cm}$ , or sensors with cell constant of  $5 \text{ cm}^{-1}$ , to measure conductivities of 0  $\mu\text{S/cm}$  to 20  $\text{mS/cm}$ .

The SC210G detector may be inserted into the process piping, for direct measurement of process liquids, or a sample of the liquid may be obtained via a piping connection. Users should thoroughly read this manual prior to using the product, so as to understand how to obtain best results when using it.

This user manual is intended to cover installation, piping and wiring, periodic inspection and maintenance for the SC210G Conductivity Detector.

This manual does not describe the units in Table shown below which are the component units of the conductivity measuring system. Each of these units comes with an instruction manual, so read the applicable manuals for details of the units concerned.

Manual Name		IM No.
SC202G, SC202SJ	2-Wire Conductivity Transmitter	IM 12D08B02-01E
FLXA21	2-Wire Liquid Analyzer	IM 12A01A02-01E
SC402G	4-Wire Conductivity Converter	IM 12D08N04-01E
SC450G	4-Wire Conductivity Converter	IM 12D08N05-01E

When you receive the SC210G detector, carefully unpack it and inspect for evidence of any damage that may have occurred during transit.

The SC210G is shipped with the specifications and options specified at order time. Confirm that the model and suffix codes on the nameplate agree with those specified in your order. For more details of model and suffix codes, refer to Section 1.2.2 later in this manual.

# ◆ For the safe use of this equipment

## ■ Safety, Protection, and Modification of the Product

- In order to protect the system controlled by the product and the product itself and ensure safe operation, observe the safety precautions described in this user's manual. We assume no liability for safety if users fail to observe these instructions when operating the product.
- If this instrument is used in a manner not specified in this user's manual, the protection provided by this instrument may be impaired.
- Be sure to use the spare parts approved by Yokogawa Electric Corporation (hereafter simply referred to as YOKOGAWA) when replacing parts or consumables.
- Modification of the product is strictly prohibited.
- The following symbols are used in the product and user's manual to indicate that there are precautions for safety:

## ■ Notes on Handling User's Manuals

- Please hand over the user's manuals to your end users so that they can keep the user's manuals on hand for convenient reference.
- Please read the information thoroughly before using the product.
- The purpose of these user's manuals is not to warrant that the product is well suited to any particular purpose but rather to describe the functional details of the product.
- No part of the user's manuals may be transferred or reproduced without prior written consent from YOKOGAWA.
- YOKOGAWA reserves the right to make improvements in the user's manuals and product at any time, without notice or obligation.
- If you have any questions, or you find mistakes or omissions in the user's manuals, please contact our sales representative or your local distributor.

## ■ Warning and Disclaimer

The product is provided on an "as is" basis. YOKOGAWA shall have neither liability nor responsibility to any person or entity with respect to any direct or indirect loss or damage arising from using the product or any defect of the product that YOKOGAWA can not predict in advance.

---

## ■ Symbol Marks

Throughout this user's manual, you will find several different types of symbols are used to identify different sections of text. This section describes these icons.



### **WARNING**

---

---

Indicates a potentially hazardous situation which, if not avoided, could result in death or serious injury.

---

---



### **CAUTION**

---

Indicates a potentially hazardous situation which, if not avoided, may result in minor or moderate injury. It may also be used to alert against unsafe practices.

---



### **IMPORTANT**

---

Indicates that operating the hardware or software in this manner may damage it or lead to system failure.

---



### **NOTE**

---

Draws attention to information essential for understanding the operation and features.

---

## ◆ After-sales Warranty

- Do not modify the product.
  
- During the warranty period, for repair under warranty consult the local sales representative or service office. Yokogawa will replace or repair any damaged parts. Before consulting for repair under warranty, provide us with the model name and serial number and a description of the problem. Any diagrams or data explaining the problem would also be appreciated.
  - If we replace the product with a new one, we won't provide you with a repair report.
  - Yokogawa warrants the product for the period stated in the pre-purchase quotation. Yokogawa shall conduct defined warranty service based on its standard. When the customer site is located outside of the service area, a fee for dispatching the maintenance engineer will be charged to the customer.
  
- In the following cases, customer will be charged repair fee regardless of warranty period.
  - Failure of components which are out of scope of warranty stated in instruction manual.
  - Failure caused by usage of software, hardware or auxiliary equipment, which Yokogawa Electric did not supply.
  - Failure due to improper or insufficient maintenance by user.
  - Failure due to modification, misuse or outside-of-specifications operation which Yokogawa does not authorize.
  - Failure due to power supply (voltage, frequency) being outside specifications or abnormal.
  - Failure caused by any usage out of scope of recommended usage.
  - Any damage from fire, earthquake, storms and floods, lightning, disturbances, riots, warfare, radiation and other natural changes.
  
- Yokogawa does not warrant conformance with the specific application at the user site. Yokogawa will not bear direct/indirect responsibility for damage due to a specific application.
  
- Yokogawa Electric will not bear responsibility when the user configures the product into systems or resells the product.
  
- Maintenance service and supplying repair parts will be covered for five years after the production ends. For repair for this product, please contact the nearest sales office described in this instruction manual.

# CONDUCTIVITY METERING SYSTEM

## Model SC210G

### CONDUCTIVITY DETECTOR

IM 12D08G03-01E 5th Edition

## CONTENTS

- ◆ Introduction .....i
- ◆ For the safe use of this equipment .....ii
- ◆ After-sales Warranty .....iv
- 1. General ..... 1-1
  - 1.1 SC210G Conductivity Detector ..... 1-1
    - 1.1.1 Conductivity Detector ..... 1-1
  - 1.2 Specifications ..... 1-2
    - 1.2.1 Standard Specifications ..... 1-2
    - 1.2.2 Model and Suffix Codes ..... 1-3
    - 1.2.3 External Dimensions ..... 1-5
- 2. Name and Function of Each Part ..... 2-1
  - 2.1 Conductivity Detector ..... 2-1
- 3. Installation and Piping, Wiring ..... 3-1
  - 3.1 Installation ..... 3-1
    - 3.1.1 Site Selection ..... 3-1
    - 3.1.2 Preparation ..... 3-1
    - 3.1.3 Installation of the Detector ..... 3-4
  - 3.2 Piping ..... 3-4
    - 3.2.1 Joint Position ..... 3-4
    - 3.2.2 Material for Piping ..... 3-5
    - 3.2.3 Notes for Piping ..... 3-5
  - 3.3 Wiring ..... 3-7
    - 3.3.1 Detector Cable Specifications ..... 3-7
    - 3.3.2 Laying Detector Cables ..... 3-7
- 4. Operation ..... 4-1
  - 4.1 Preparation for Operation ..... 4-1
    - 4.1.1 Checking Piping and Wiring ..... 4-1
    - 4.1.2 Flowing Measured Solution ..... 4-1
    - 4.1.3 Checking Operation ..... 4-1
  - 4.2 Steady-State Operation ..... 4-2
    - 4.2.1 If any Problem Arises During Operation ..... 4-2
    - 4.2.2 Cautions When Stopping or Resuming Operation ..... 4-2

---

<b>5.</b>	<b>Inspection and Maintenance .....</b>	<b>5-1</b>
5.1	<b>Conductivity Detector Maintenance .....</b>	<b>5-1</b>
5.1.1	Sensor Cleaning .....	5-1
5.1.2	Replacing the Sealing O-ring.....	5-2
5.1.3	Replacement of a Faulty Electrode.....	5-3
	<b>Customer Maintenance Parts List.....</b>	<b>CMPL 12D08F00-01E</b>
	<b>Revision Information .....</b>	<b>i</b>

# 1. General

## 1.1 SC210G Conductivity Detector

### 1.1.1 Conductivity Detector

The conductivity detector can be classified into the following two types in terms of application and cell constant.

SC210G-A conductivity detector for low range (cell constant:  $0.05\text{ cm}^{-1}$ )

SC210G-B conductivity detector for medium range (cell constant:  $5\text{ cm}^{-1}$ )

These conductivity detectors are structured (follow-through structure) to introduce a measuring solution to themselves through a connected sampling pipe (nominal diameter: 15A).

The SC210G-A and SC210G-B have a type which is connected directly to a process pipe (direct insertion type).

- (1) SC210G-A conductivity detector for low range (cell constant:  $0.05\text{ cm}^{-1}$ )

This detector's electrode is a stainless steel (SUS316) 2-electrode coaxial type and is used to measure a solution whose conductivity is 0 to  $200\text{ }\mu\text{S/cm}$ .

- (2) SC210G-B conductivity detector for medium range (cell constant:  $5\text{ cm}^{-1}$ )

This detector's electrode is a 2-electrode type having three ringed platinum electrodes arranged at an equal distance in its glass tube bore (of the three platinum electrodes, two on the sides are short-circuited internally and serve as a pair with the middle electrode). It is used to measure a solution whose conductivity is  $200\text{ }\mu\text{S/cm}$  to  $20\text{ mS/cm}$ .

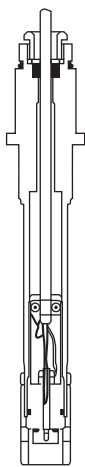

SC210G-A  
cell constant:  $0.05\text{ cm}^{-1}$

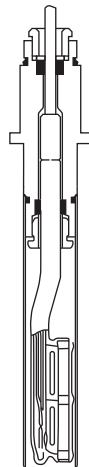

SC210G-B  
cell constant:  $5\text{ cm}^{-1}$

**Figure 1.1 Electrode Construction of the Conductivity Detectors**

## 1.2 Specifications

This chapter describes the specifications of the SC210G Conductivity Detector.

For the specifications of other devices (for example, the SC202G, SC202SJ, FLXA21 two-wire conductivity transmitter, the PH201G distributor), refer to their respective user's manuals.

### 1.2.1 Standard Specifications

Applicable to SC202G, SC202SJ, FLXA21 transmitters and SC450G converters

Object of measurement : Conductivity of solutions

Measuring principle : Two-electrode system

Cell constant : 0.05 cm<sup>-1</sup>, 5 cm<sup>-1</sup>

Measuring range : 0 - 0.5 μS/cm to 0 - 200 μS/cm (Cell constant: 0.05 cm<sup>-1</sup>)  
0 - 200 μS/cm to 0 - 20 mS/cm (Cell constant: 5 cm<sup>-1</sup>)

Temperature Range : 0 to 105 °C (chamber material: SCS14)  
0 to 100 °C (chamber material: Polypropylene)

Pressure range : 0 to 1 MPa (chamber material: SCS14)  
0 to 500 kPa (chamber material: Polypropylene)

Measured solution condition :

Although flow rate is not limited in measurement, less than 20 L/min is recommended for flow-through type. If slurry is included in measured solutions in flow-through type detectors, the electrode part and the inside of solution chamber may be worn significantly. Air bubbles should not be mixed in the measured solutions to obtain correct measured values.

Temperature sensor : Thermistor (PB36NTC)

Wet part Materials

SC210G-A : For sensor, SUS 316 stainless steel, Viton (O-ring) and Polytrifluorochloroethylene  
For body, SUS316 stainless steel, polypropylene and Viton (O-ring)

SC210G-B : For sensor, Platinum, glass and Viton (O-ring)  
For body, SUS316 stainless steel, polypropylene and Viton (O-ring)

Construction : JIS C0920 watertight (equal to NEMA 4)

Combination of detector and converters

Converter \ Type of terminals	Pin	Ring M4	Ring M3
Converter: SC100	N.A.		
Transmitter: SC202G, SC202SJ	Yes	N.A.	Yes (Note 1)
Converter: SC402G (Note 3)	Yes	N.A.	N.A.
Converter: SC450G	(Note 2)	N.A.	Yes
Analyzer: FLXA21	Yes	Yes	N.A.

Note 1: Applicable when option code /TB (screw terminal) specified for SC202G/SC202SJ.

Note 2: Both pin and M3 ring can be used for SC450G, but M3 ring are recommended.

Note 3: SC402G has been terminated.

## 1.2.2 Model and Suffix Codes

### SC210G Conductivity Detector

Model	Suffix Code	Option Code	Description	
SC210G	.....	.....	Conductivity detector	
Measuring range	- A - B	..... .....	Low range; cell constant: 0.05 cm <sup>-1</sup> Medium range; cell constant: 5 cm <sup>-1</sup>	
Construction	Screw-in type	- 100	..... R1-1/2	
		- 103	..... 1-1/2NPT male	
	Flange type	- 206	.....	JIS 10K 50 RF flange
		- 207	.....	ANSI Class150 2 RF flange (with serration)
	Flow-through type *1	- 208	.....	JPI Class150 2 RF flange
		- 302	.....	Rc1/2 female, chamber material : SCS14
		- 312	.....	Rc1/2 female, chamber material : PP
		- 303	.....	1/2NPT female, chamber material : SCS14
		- 313	.....	1/2NPT female, chamber material : PP
		- 304	.....	JIS 10K 15 RF flange, chamber material: SCS14
		- 314	.....	JIS 10K 15 FF flange, chamber material: PP
		- 305	.....	ANSI Class150 1/2 RF flange with serration, chamber material: SCS14
	- 315	.....	ANSI Class150 1/2 FF flange, chamber material: PP	
With gate valve	- 402	.....	JPI Class150 1/2 RF flange, chamber material: SCS14	
	- 403	.....	R1-1/4 1-1/4NPT male	
Sensor length	- L015 - L030 - L050 - L100 - L150 - L200	..... ..... ..... ..... ..... .....	150 mm (Standard) 300 mm *2 500 mm *2 1000 mm *2 1500 mm *2 2000 mm *2	
Cable length	- 03 - 05 - 10 - 15 - 20 - AA - BB - CC - DD - EE - Y1 - Y2 - Y3 - Y4 - Y5	..... ..... ..... ..... ..... ..... ..... ..... ..... ..... ..... ..... ..... ..... .....	3 m (M4 ring terminals) *4 5 m (M4 ring terminals) *4 10 m (M4 ring terminals) *4 15 m (M4 ring terminals) *4 20 m (M4 ring terminals) *3 *4 3 m (pin terminals) 5 m (pin terminals) 10 m (pin terminals) 15 m (pin terminals) 20 m (pin terminals) *3 3 m (M3 ring terminals) *5 5 m (M3 ring terminals) *5 10 m (M3 ring terminals) *5 15 m (M3 ring terminals) *5 20 m (M3 ring terminals) *5	
Style code	*A	.....	Style A	
Option		/SCT /ANSI /PF /PS /SS /X1 /DG1 /MCT	Stainless steel tag plate With ANSI connection adaptor *6 DAI-EL perflrow (perfluoro-elastomer) specification *7 SUS mounting hardware (for PP construction) SUS mounting hardware (for SCS14 construction) Epoxy-coated (baked) Oil-prohibited use (Degrease cleaning treatment) (except for gate valve) Material Certificate *8 (except for gate valve)	

- \*1: The model is not equipped with a mounting brackets, place an order on the SC210G with option code /PS or /SS when you select flow-through model. The PP chamber material can have cracks or splits unless it is not supported by a mounting hardware.
- \*2: Only for Screw-in type and Flange type
- \*3: Impossible use for the SC400G
- \*4: Used for connection to FLXA21.
- \*5: Used for connection to SC450G or SC202/TB.
- \*6: Adaptor for cable inlet (carbon steel)
- \*7: Materials of O-ring of electrode assembly and chamber seal become perfluoro-elastomer.  
But, in construction -402 and -403, the sealing part of gate valve doesn't become the elastomer
- \*8: Additional lead time is required.

## (2) Spare Parts for SC210G

Parts No.	Description
K9208EA	150 mm electrode Assembly (C=0.05 cm <sup>-1</sup> ) for SC210G-A
K9208EB	500 mm electrode Assembly (C=0.05 cm <sup>-1</sup> ) for SC210G-A
K9208EC	1000 mm electrode Assembly (C=0.05 cm <sup>-1</sup> ) for SC210G-A
K9208ED	1500 mm electrode Assembly (C=0.05 cm <sup>-1</sup> ) for SC210G-A
K9208EE	2000 mm electrode Assembly (C=0.05 cm <sup>-1</sup> ) for SC210G-A
K9208EF	300 mm electrode Assembly (C=0.05 cm <sup>-1</sup> ) for SC210G-A
K9315NA	150 mm electrode Assembly (C=0.05 cm <sup>-1</sup> ) with perfluoro-elastomer, for SC210G-A
K9315NB	500 mm electrode Assembly (C=0.05 cm <sup>-1</sup> ) with perfluoro-elastomer, for SC210G-A
K9315NC	1000 mm electrode Assembly (C=0.05 cm <sup>-1</sup> ) with perfluoro-elastomer, for SC210G-A
K9315ND	1500 mm electrode Assembly (C=0.05 cm <sup>-1</sup> ) with perfluoro-elastomer, for SC210G-A
K9315NE	2000 mm electrode Assembly (C=0.05 cm <sup>-1</sup> ) with perfluoro-elastomer, for SC210G-A
K9315NF	300 mm electrode Assembly (C=0.05 cm <sup>-1</sup> ) with perfluoro-elastomer, for SC210G-A
K9208KA	Electrode Assembly (C=0.05 cm <sup>-1</sup> ) of gate valve type for SC210G-A
K9315NN	Electrode Assembly (C=0.05 cm <sup>-1</sup> ) of gate valve type with perfluoro-elastomer for SC210G-A
K9208JA	150 mm electrode Assembly (C=5 cm <sup>-1</sup> ) for SC210G-B
K9208JB	500 mm electrode Assembly (C=5 cm <sup>-1</sup> ) for SC210G-B
K9208JC	1000 mm electrode Assembly (C=5 cm <sup>-1</sup> ) for SC210G-B
K9208JD	1500 mm electrode Assembly (C=5 cm <sup>-1</sup> ) for SC210G-B
K9208JE	2000 mm electrode Assembly (C=5 cm <sup>-1</sup> ) for SC210G-B
K9208JF	300 mm electrode Assembly (C=5 cm <sup>-1</sup> ) for SC210G-B
K9315NG	150 mm electrode Assembly (C=5 cm <sup>-1</sup> ) with perfluoro-elastomer, for SC210G-B
K9315NH	500 mm electrode Assembly (C=5 cm <sup>-1</sup> ) with perfluoro-elastomer, for SC210G-B
K9315NJ	1000 mm electrode Assembly (C=5 cm <sup>-1</sup> ) with perfluoro-elastomer, for SC210G-B
K9315NK	1500 mm electrode Assembly (C=5 cm <sup>-1</sup> ) with perfluoro-elastomer, for SC210G-B
K9315NL	2000 mm electrode Assembly (C=5 cm <sup>-1</sup> ) with perfluoro-elastomer, for SC210G-B
K9315NM	300 mm electrode Assembly (C=5 cm <sup>-1</sup> ) with perfluoro-elastomer, for SC210G-B
K9208MA	Electrode Assembly (C=5 cm <sup>-1</sup> ) of gate valve type for SC210G-B
K9315NP	Electrode Assembly (C=5 cm <sup>-1</sup> ) of gate valve type with perfluoro-elastomer for SC210G-B
K9315QA	3 m cable for SC210G (M4 ring terminals, SC210G...-03)
K9315QB	5 m cable for SC210G (M4 ring terminals, SC210G...-05)
K9315QC	10 m cable for SC210G (M4 ring terminals, SC210G...-10)
K9315QF	15 m cable for SC210G (M4 ring terminals, SC210G...-15)
K9315QG	20 m cable for SC210G (M4 ring terminals, SC210G...-20)
K9315QR	3 m cable for SC210G (pin terminals)
K9315QS	5 m cable for SC210G (pin terminals)
K9315QT	10 m cable for SC210G (pin terminals)
K9315QU	15 m cable for SC210G (pin terminals)
K9315QV	20 m cable for SC210G (pin terminals)
K9315QJ	3 m cable for SC210G (M3 ring terminals)
K9315QK	5 m cable for SC210G (M3 ring terminals)
K9315QL	10 m cable for SC210G (M3 ring terminals)
K9315QM	15 m cable for SC210G (M3 ring terminals)
K9315QQ	20 m cable for SC210G (M3 ring terminals)
K9050AT	Viton O-ring (for screw-in type, flange type and flow-through type)
K9050MR	Viton O-ring (for gate valve type)
K9319RN	Perfluoro-elastomer O-ring (for all types)

(Note) "C" is cell constant of the detector.

### 1.2.3 External Dimensions

#### SC210G Conductivity Sensor

##### (1) Screw-in Type

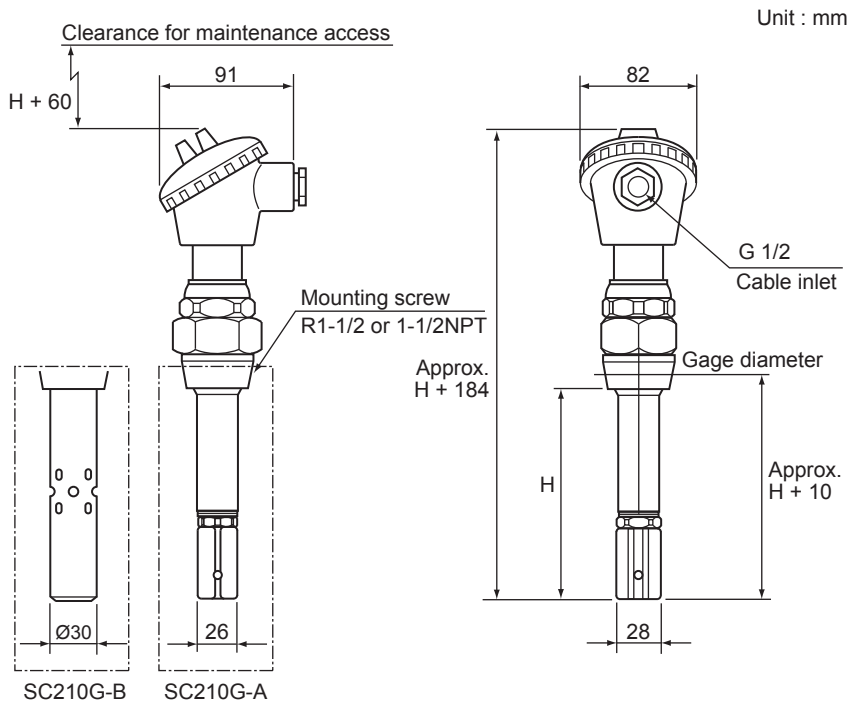

• Sensor length

Model and Suffix Code	H
SC210G - □ - 10□ - L015 - □ □ *A	150
SC210G - □ - 10□ - L030 - □ □ *A	300
SC210G - □ - 10□ - L050 - □ □ *A	500
SC210G - □ - 10□ - L100 - □ □ *A	1000
SC210G - □ - 10□ - L150 - □ □ *A	1500
SC210G - □ - 10□ - L200 - □ □ *A	2000

Figure 1.2 Screw-in Type

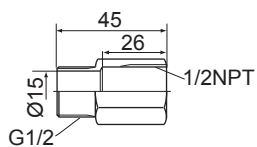
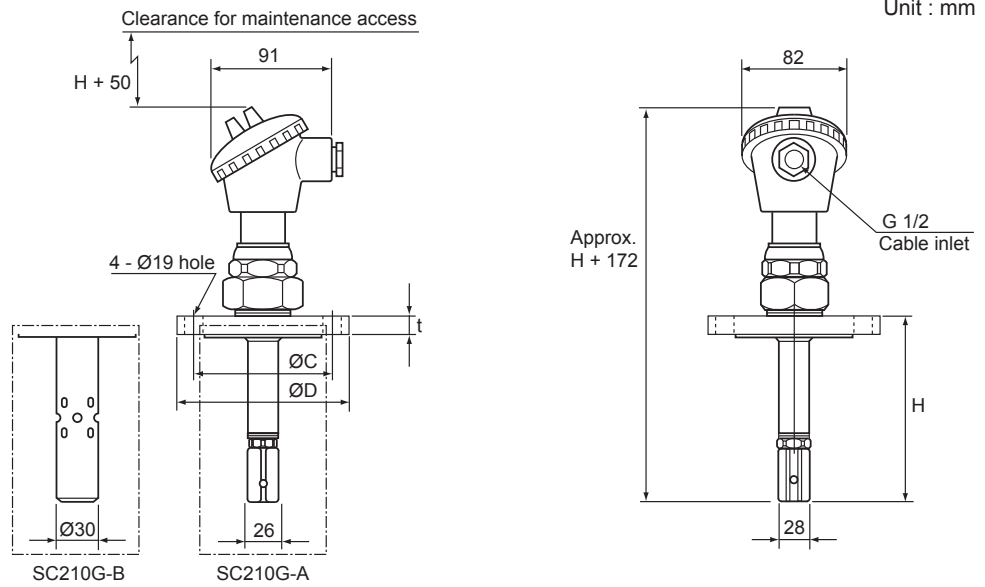

Figure 1.3 Cable inlet adaptor of "/ANSI" option

(2) Flange Type



• Flange

Model and Suffix Code	Flange rating	ØC	ØD	t
SC210G - □ - 206 - L □ □ □ - □ □ * A	JIS 10K 50 RF	120	155	16
SC210G - □ - 207 - L □ □ □ - □ □ * A	ANSI Class150 2 RF	120.7	152.4	19.1
SC210G - □ - 208 - L □ □ □ - □ □ * A	JPI Class150 2 RF	120.6	152	19.5

Note : ANSI flange with serrations.

• Sensor length

Model and Suffix Code	H
SC210G - □ - 20□ - L015 - □ □ * A	162
SC210G - □ - 20□ - L030 - □ □ * A	312
SC210G - □ - 20□ - L050 - □ □ * A	512
SC210G - □ - 20□ - L100 - □ □ * A	1012
SC210G - □ - 20□ - L150 - □ □ * A	1512
SC210G - □ - 20□ - L200 - □ □ * A	2012

Figure 1.4 Flange Type

(3) Flow-through Type

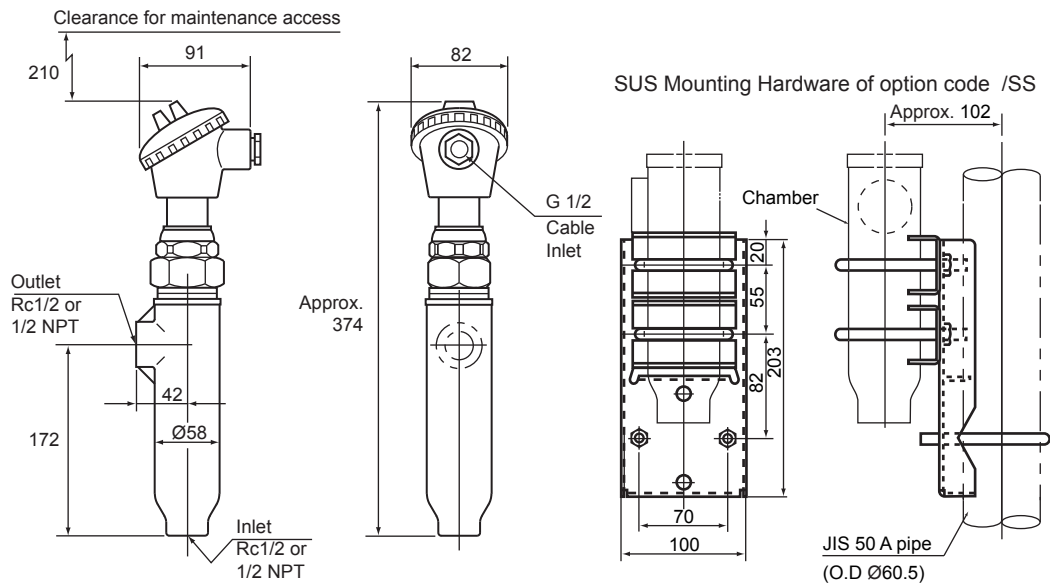
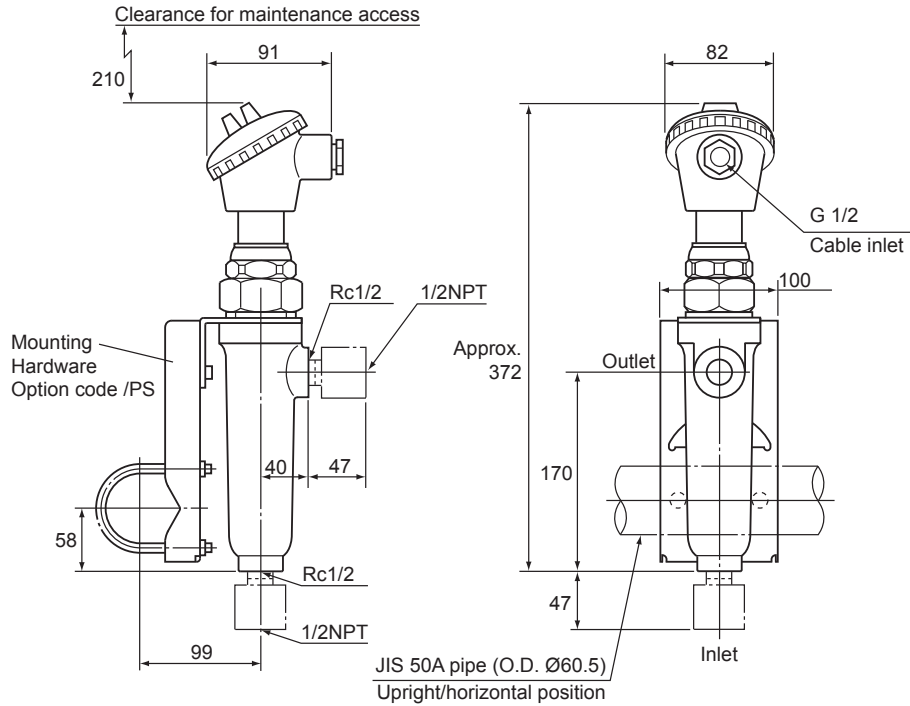

Figure 1.5 Flow-through Screw Connection Type (Chamber Material: SCS14)

Unit : mm



Flow-through type + Mounting hardware (option code /PS)  
(screw connection, chamber material: polypropylene)

**Figure 1.6 Flow-through Screw Connection Type (Chamber Material: polypropylene)**

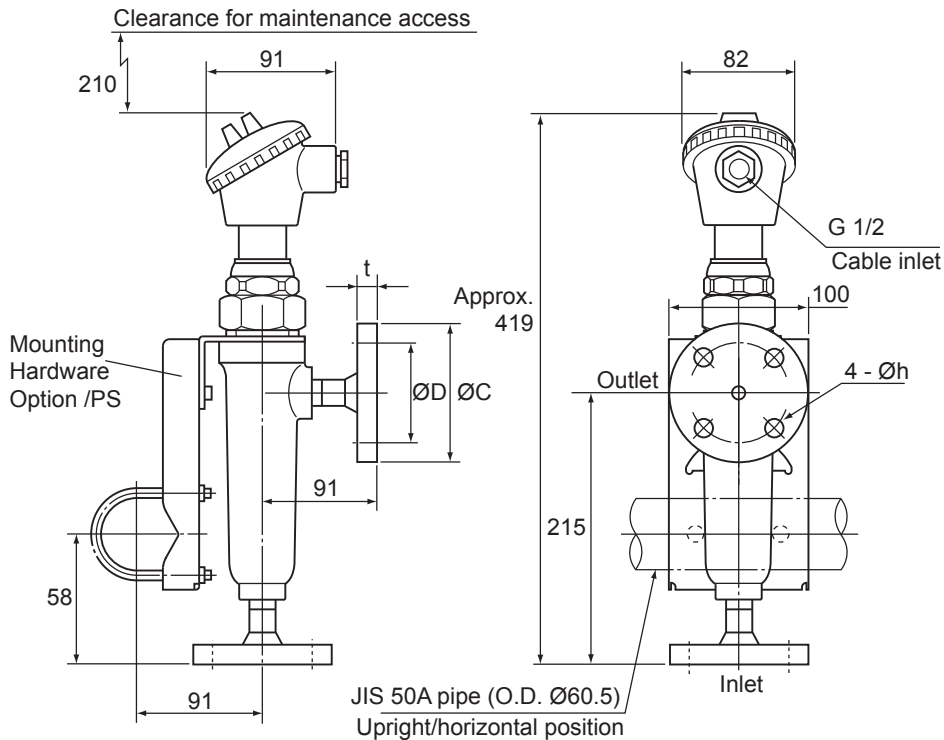

Flow-through type + Mounting hardware (/PS)  
(flange connection, chamber material: polypropylene)

Flange rating	ØC	ØD	t	Øh
JIS 10K 15 FF	70	95	12	15
ANSI Class150 1/2 FF	60.5	88.9	12	15

**Figure 1.7 Flow-through with Flange Connection Type (Material: polypropylene)**

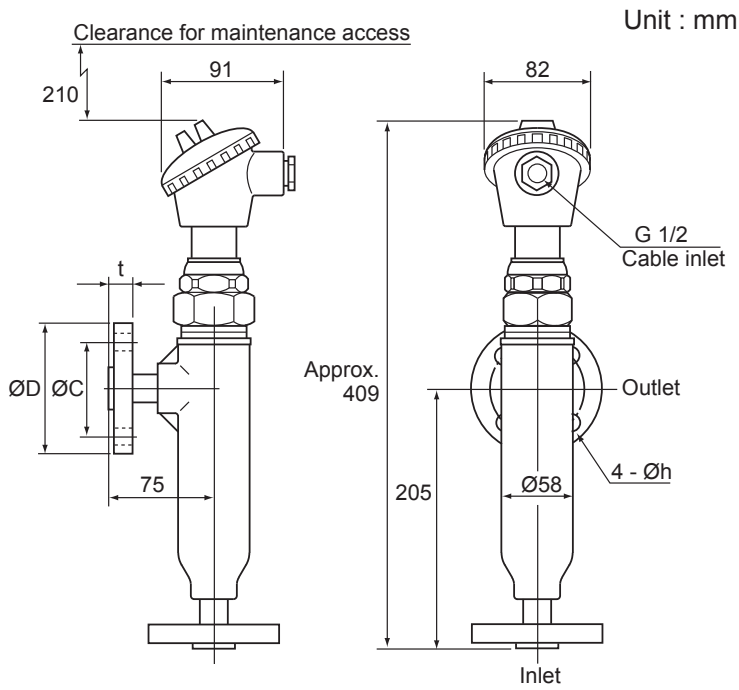

Flow-through type (flange connection, chamber material: SCS14)

Flange rating	ØC	ØD	t	Øh
JIS 10K 15 RF	70	95	12	15
ANSI Class150 1/2 RF	60.5	88.9	11.2	15.7
JPI Class150 1/2 RF	60.3	89	10.9	16

(Note) ANSI flange with serration.

Figure 1.8 Flow-through with Flange Connection Type (Material: SCS14)

(4) Screw-in with Gate Valve Type

SC210G-A

SC210G-B

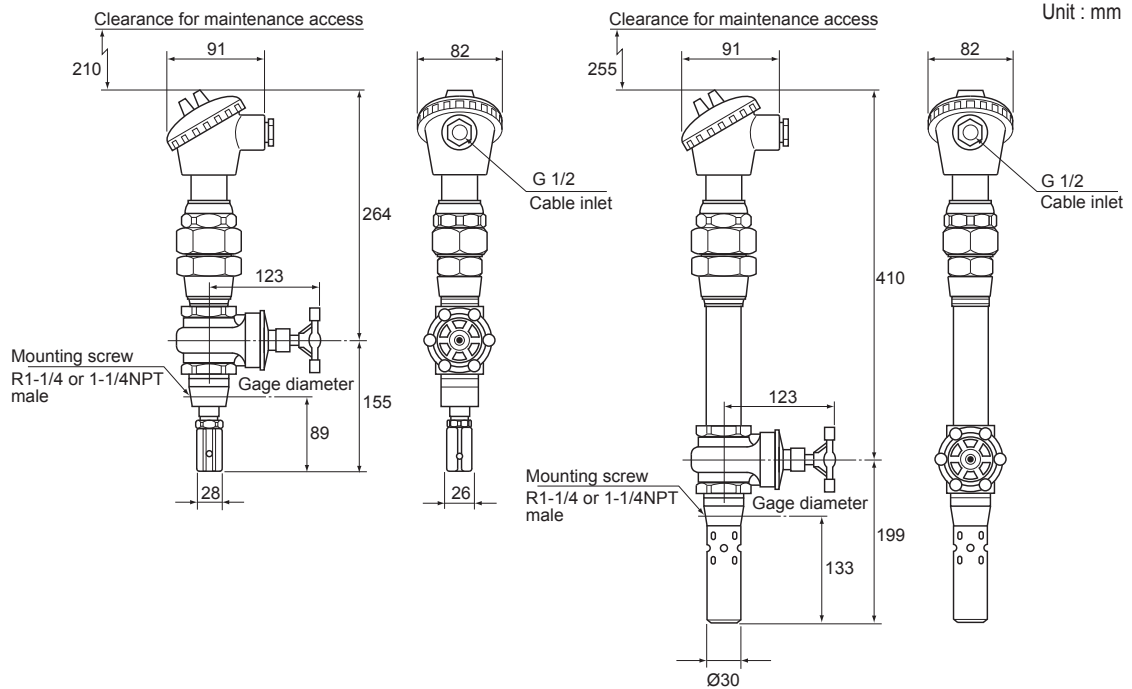

Figure 1.9 Screw-in with Gate Valve Type

# 2. Name and Function of Each Part

This chapter explains the name and function of each part of the SC210G conductivity detector.

## 2.1 Conductivity Detector

- Direct insertion type conductivity detector

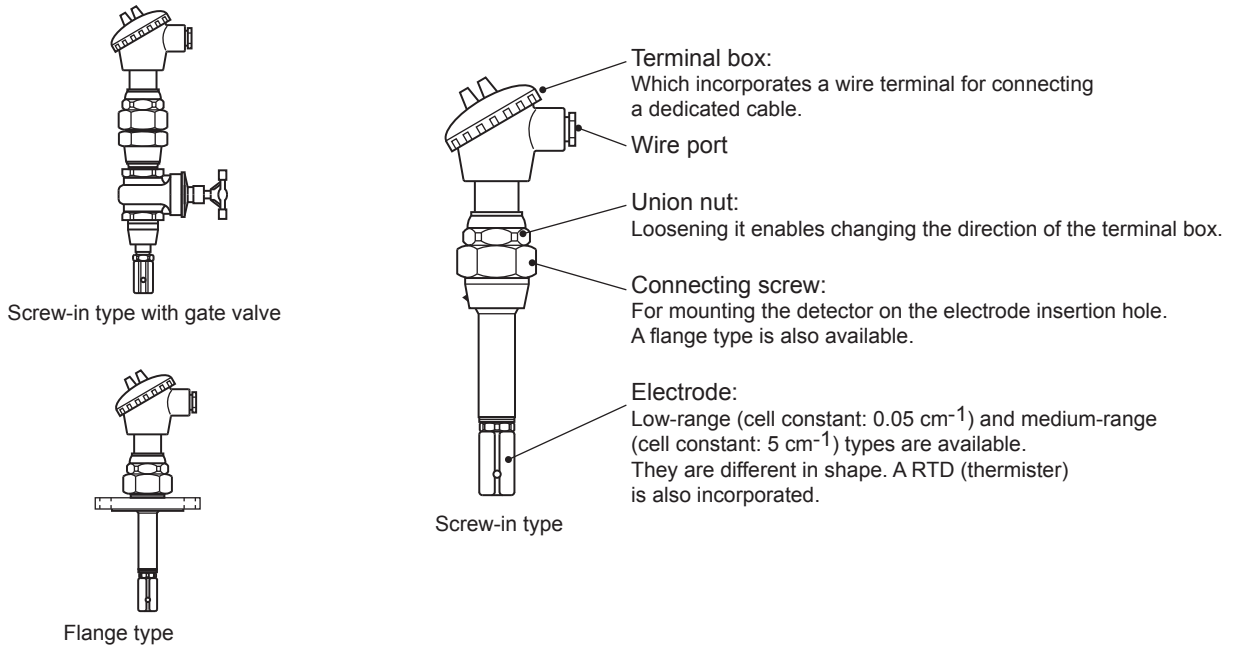

- Flow-through type conductivity detector

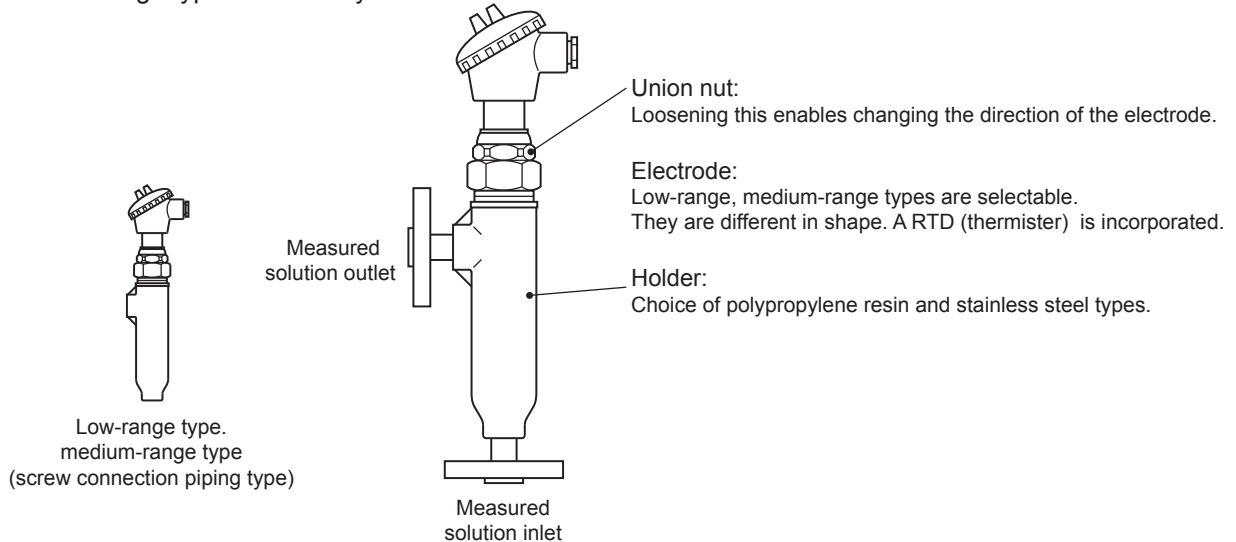

**Figure 2.1** Conductivity Detector



## 3. Installation and Piping, Wiring

This chapter explains the installation and piping procedure for the SC210G Conductivity Detector.

For installation of the Conductivity Transmitter/Conductivity Converter, and wiring, refer to individual User's Manual.

After close inspection at the plant, the SC210G conductivity detector is packed carefully so as not to be damaged during shipment. When unpacking, handle carefully to avoid any violent shock.

After unpacking is completed, inspect the appearance visually and confirm that there is no damage. For confirmation, look at the model code shown on the name plate and verify that the product is the ordered one. Additionally, confirm the length of the dedicated cable provided for the detector.

### 3.1 Installation

#### 3.1.1 Site Selection

Install the conductivity detector in a place where:

- Facilitates inspection and maintenance
- The temperature and pressure of the measured solution satisfy their usable conditions
- The measured solution contains no bubbles affecting the measured value
- There is no change in the level of the measured solution

#### 3.1.2 Preparation

Conductivity detectors are divided into direct insertion types, which are attached directly to the electrode insertion hole provided on a process pipe, etc., and flow-through types which are connected to a sampling pipe.

When using the direct insertion type conductivity detector, provide it with an electrode insertion hole of an appropriate screw size or flange size.

When using a flow-through type conductivity detector whose holder is made of polypropylene resin, provide with a nominal 50A pipe (outer diameter: 60.5 mm) for mounting the detector. The mounting pipe for mounting can be set vertically or horizontally.

Note: When the holder is made of polypropylene resin, be sure to fix the detector on pipes or other structure to prevent the pipe joint from breakage.  
When the holder material is stainless steel (SCS14), support the detector by conduit pipe. Thus it is not necessary to install special mounting pipe.

#### <Electrode Insertion Hole Handling Procedure>

When handling the electrode insertion hole, consider the following points:

- Does the measured solution overflow through the electrode insertion hole when the conductivity detector is removed for maintenance?
- Can the conductivity detector be removed for maintenance even if the process solution cannot be stopped arbitrarily?

In addition, the mounting direction of the detector is not especially limited.

## (1) Screw-in Type

Figure 3.1 shows the procedure for electrode insertion hole processing in case of the screw-in type.

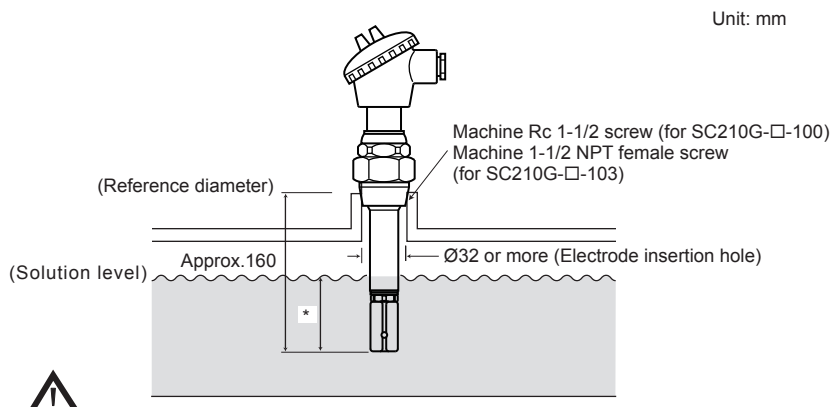

\*: Always keep the electrode tip dipped more than 60 mm for SC210G-A, more than 100 mm for SC210G-B.

**Figure 3.1 Procedure for Electrode Insertion Hole Processing for the Screw-in Direct Insertion Type Detector.**

Figure 3.2 shows the procedure for the direct insertion type with a gate valve.

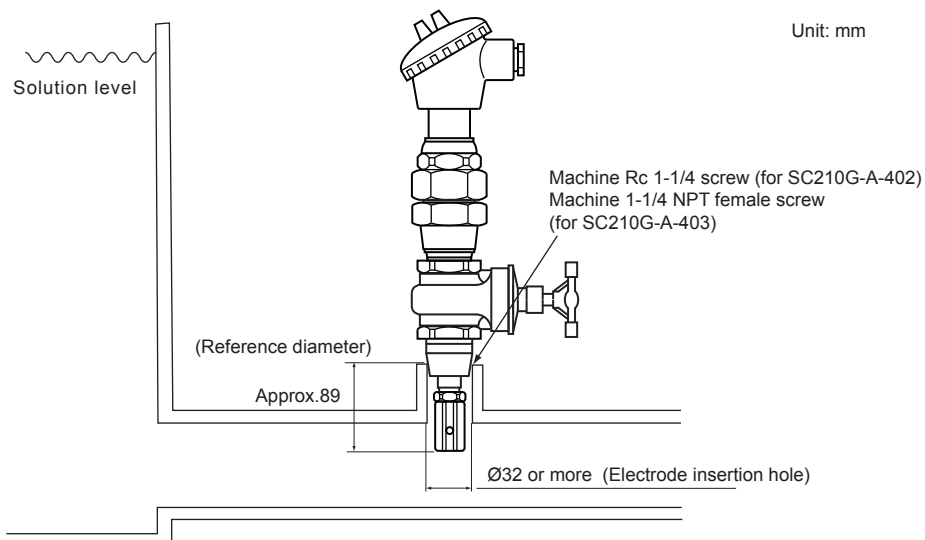

**Figure 3.2 Procedure for Electrode Insertion Hole Processing for the Direct Insertion Type Detector with Gate Valve**

(2) Flange Type

Figure 3.3 Shows the procedure for electrode insertion hole processing for the flange type.

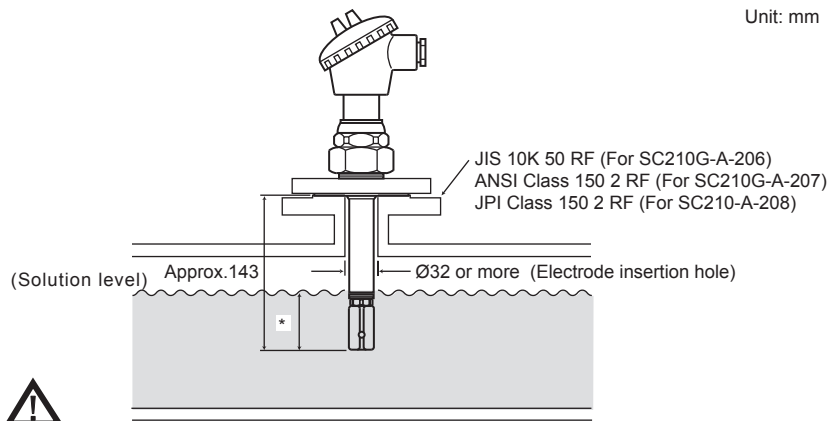

\*: Always keep the electrode tip dipped more than 60 mm for SC210G-A, more than 100 mm for SC210G-B.

**Figure 3.3 Procedure for Electrode Insertion Hole Processing for the Flange Type Direct Insertion Type Detector**

**<Procedure for the Installation of Flow-through-type Detector Mounting Pipe>**

This procedure is only applicable for the polypropylene resin holder.

Install a 50A pipe of nominal size (outer diameter: 60.5 mm) with sufficient strength vertically or horizontally. When the mounting pipe is installed vertically, the conduit pipe is free to install horizontally.

The detector holder is structured to permit changing the direction of the measured solution outlet backwards / forwards and right / left.

Cable lead-in port can also be changed in any direction horizontally. The detector can be fixed on a wall by removing the pipe mounting bracket.

When mounting the detector in this manner, process holes as shown in Figure 3.4.

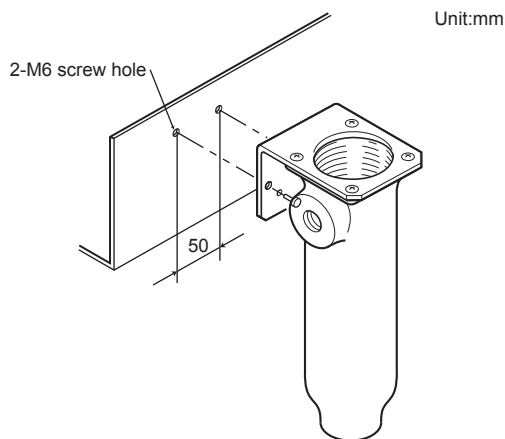

**Figure 3.4 Processing of Holes for Mounting on the Wall**

### 3.1.3 Installation of the Detector

When the installation preparations mentioned in section 3.1.2 are completed, install the detector.

In case of the screw-in direct insertion type detector, wind seal tape on the thread part and drive it fully into the electrode insertion hole.

In case of the flange type direct insertion detector, put a gasket between the detector's flange surfaces and electrode insertion hole and tighten the four bolts with equal force.

In case of the flow-through-type detector, fix the detector at the specified position of the mounting pipe.

When using the SC210G conductivity detector, after installing it, adjust the direction of the terminal wiring port so as to facilitate wiring. Loosening the union nut allows the terminal box to turn freely.



#### NOTE

Note that you have to loosen the union nut when you adjust the direction of the terminal port. If you do not loosen the union nut, the internal wiring will be damaged.

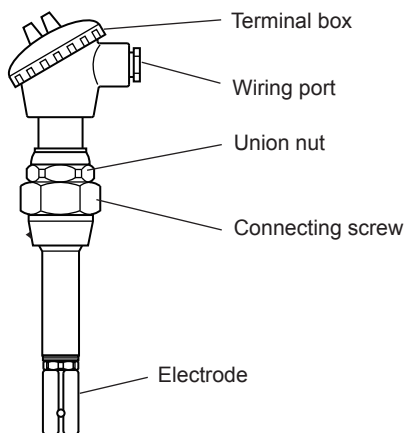

Figure 3.5 Union Nut for Direction Adjustment of Terminal Box

## 3.2 Piping

When using the flow-through-type conductivity detector, if the detector is not connected directly to a process pipe, install a sampling pipe to introduce the measured solution to the detector.

The procedure for installation of the sampling pipe is explained here.

### 3.2.1 Joint Position

Pipe joint holes are provided on the bottom and side of the holder, and the bottom pipe joint hole faces the measured solution inlet and side pipe joint hole, the measured solution outlet.

In case of the stainless steel (SCS14) holder, the side pipe joint hole can be set in any horizontal direction.

The polypropylene resin holder is assembled so that the pipe joint hole faces right when the fixing bracket is at the rear, as a rule. By changing the installation direction of the bracket, the pipe joint hole can be made to face to the left or front. (See Figure 3.6)

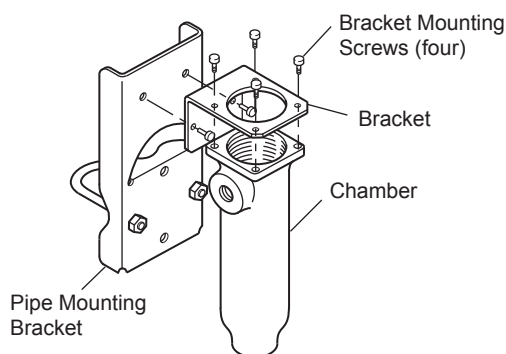

**Figure 3.6** Bracket for Fixing the Polypropylene Resin Holder

### 3.2.2 Material for Piping

When connecting a pipe to the detector, use one of the following:

#### (1) For the Polypropylene Resin (PP) Holder

- Hard vinyl chloride tube (JIS K9741): nominal size: A16
- Polypropylene resin tube: nominal size: A16
- Wired soft vinyl chloride tube: nominal size: A15

#### (2) For the Stainless Steel (SCS 14) Holder

- Stainless steel pipe (JIS G3459) for piping  
SUS304 or SUS316: nominal size: A15

### 3.2.3 Notes for Piping

#### (1) Pressure of Measured solution

For the SC210G-A and SC210G-B conductivity detector, when the holder is made of stainless steel, the allowable maximum pressure is 1 MPa in terms of the strength. For the polypropylene resin holder, the allowable maximum pressure is 500 kPa.

The allowable maximum pressure depends on the materials of tube.

#### (2) Temperature of Measured solution

For the SC210G-A and SC210G-B conductivity detector, the allowable maximum temperature is 105°C when the material of the holder is stainless steel, and 100°C when it is polypropylene resin.

Meanwhile, conductivity differs in even the same solution depending on the temperature.

In the conductivity transmitter and conductivity converters, conductivity compensated by the temperature is obtained by setting a reference temperature and temperature compensation coefficient. Thus, the less the temperature of the measured solution varies from the reference temperature, the more excellent the measuring accuracy becomes.

#### (3) Flow rate of Measured solution

Because the flow rate does not affect measuring accuracy, it is not especially necessary to control the flow rate. However, when slurry is contained in the measured solution, if it passes through the detector at a large flow rate, the electrode and holder may be worn or damaged.

Except when a large flow rate is needed, it is recommended to keep it below 20 L/min.

**(4) Bubbles in Measured solution**

If a large amount of bubbles exist in the measured solution, the measured value deflects, disturbing proper measurement.

When bubbles exist in the measured solution in a process pipe, take appropriate measures; for example, by providing an overflow tank as shown in Figure 3.7.

**(5) Safety at Maintenance Time**

When removing the electrode for inspection and maintenance, mount a stop valve to the pipe to prevent measured solution from spouting from the holder.

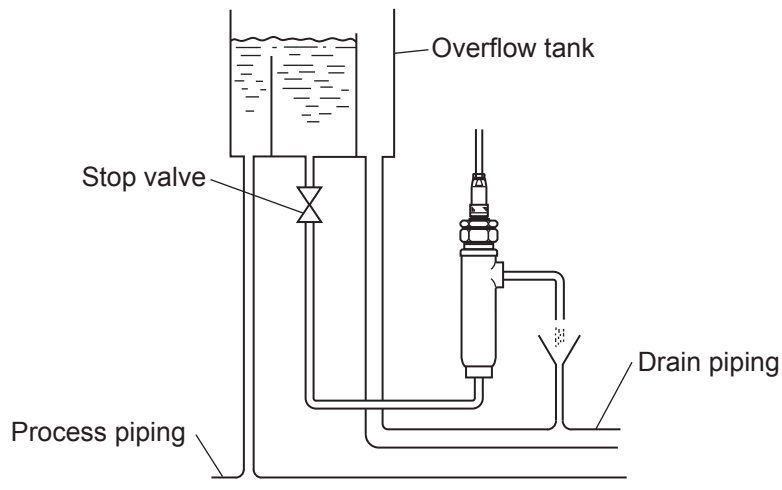

**Figure 3.7 Example of Sampling Piping with Bubble Removal Function**

### 3.3 Wiring

3 m, 5 m, 10 m, 15 m or 20 m long detector cables are supplied with the conductivity detector according to the customer's specifications. Connect the detector cables to the converter terminals (see Figure 3.8). Ring-shaped and Pin-shaped terminals are available.

#### 3.3.1 Detector Cable Specifications

- Cable length:    3 meters (suffix code: -03, -AA, -Y1)  
                       5 meters (suffix code: -05, -BB, -Y2)  
                       10 meters (suffix code: -10, -CC, -Y3)  
                       15 meters (suffix code: -15, -DD, -Y4)  
                       20 meters (suffix code: -20, -EE, -Y5)

Cable outside diameter:

Approximately 10.5 mm

Maximum cable temperature:

50°C

Terminal treatment:

Detector: Ring-shaped terminals

Converter: Pin-shaped terminals or ring-shaped terminals

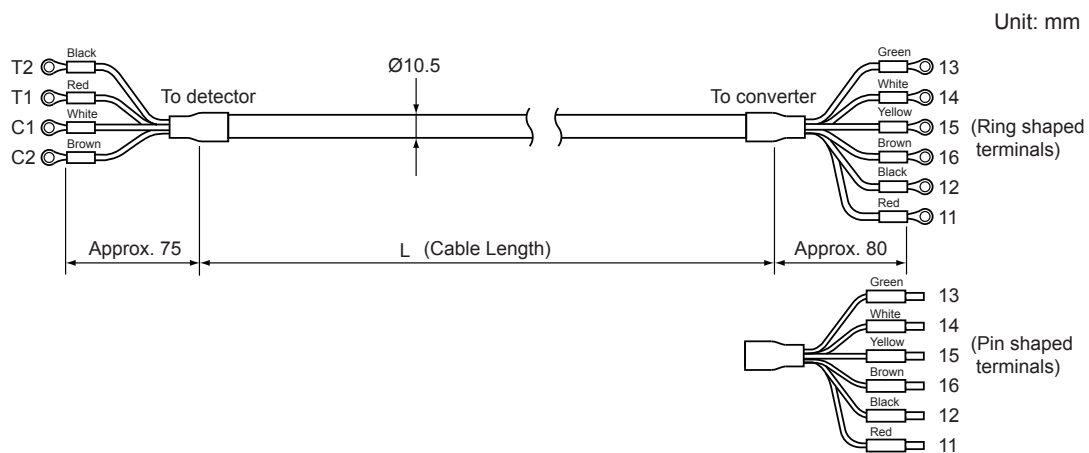

Figure 3.8    Detector Cable

#### 3.3.2 Laying Detector Cables

##### [Notes for laying detector cables]

- The conductivity detector requires calibration. The sensor should be easy to remove for calibration and maintenance.
- Cabling should not touch any pipes or the like that may get hotter than 50°C.

##### [Procedures for laying detector cables]

First check that the inside of the connector is not wet. Then connect cables to the detector. After connecting, tighten the connector locknut completely, to maintain rainproofness.

(Note) The resistance value between cable cores 11 (12) and 13 (14), 11 (12) and 15 (16) and 13 (14) and 15 (16) usually should be at least 2 MΩ.

Connect other end of the detector cable to the converter terminals. Check the marking on cable cores and connect each core to the corresponding converter terminal.

(Note) For more details on converter wiring, including the converter cable entry port, refer to the separated converter user's manual.

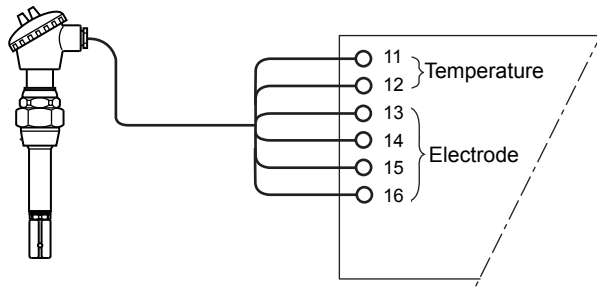

SC210G Conductivity Detector (two-electrode system)  
Applicable Converter / Transmitter: SC450G, SC202G, SC202SJ, FLXA21

**Figure 3.9 Connecting Detector Cable**

#### Applicable transmitter/converter for SC210G

Converter	Type of terminals	Pin	Ring M4	Ring M3
Converter: SC100			N.A.	
Transmitter: SC202G, SC202SJ		Yes	N.A.	Yes (Note 1)
Converter: SC402G		Yes	N.A.	N.A.
Converter: SC450G		(Note 2)	N.A.	Yes
Analyzer: FLXA21		Yes	Yes	N.A.

Note 1: Applicable when option code /TB (screw terminal) specified for SC202G/SC202SJ.

Note 2: Both pin and M3 ring can be used for SC450G, but M3 ring are recommended.

## 4. Operation

Check that the conductivity measuring system is operating correctly and providing appropriate measurements. Then place the system in steady operation. For converter operating instruction, refer to the separate converter User's Manual.

This chapter provides operating instructions for detectors.

### 4.1 Preparation for Operation

#### 4.1.1 Checking Piping and Wiring

##### [Checking Wiring]

Check that detector cable connections are correct.

- Check that calibration can be performed without any problems.
- Check that the detector cable is appropriately protected from damage.
- Check that the detector cable length is appropriate.

##### [Piping and detector installation conditions]

- Confirm that (temperature and corrosion resistance of) piping materials is appropriate for the solution(s) to be measured.
- Check that the solution level reaches the measured solution outlet when the flow of measured solution is started.
- Check that the measured solution outlet of the detector is oriented to point to the downstream side of the piping.
- Check that the detector can be readily removed for maintenance.

#### 4.1.2 Flowing Measured Solution

Check that there are no problems in flowing the measured solution:

- Check piping connections for measured solution leaks.
- Check that pressure and temperature are within the permitted operating ranges.

#### 4.1.3 Checking Operation

After setting the operating parameters and calibrating, run the conductivity measuring system and check that measurements are normal.

- Check whether bubbles in the measured solution are affecting measurement stability and accuracy.
- Check whether there are rapid changes in solution temperature which may affect accuracy of reference-temperature-converted conductivity measurement.

(Note) If there any problems with measurement accuracy, try slowing down the flow velocity, changing the measurement point, and also avoid mixing solutions with different temperatures.

## 4.2 Steady-State Operation

In steady-state operation, perform periodical calibrations using standard solutions to maintain the measurement accuracy. For details of checks and maintenance to be performed during steady-state operation, refer to the separate converter User's Manual.

(Note) When the measured solution is free of contaminants, the SC210G detector can operate without maintenance for extended periods of time (usually, one year or so).

### 4.2.1 If any Problem Arises During Operation

If the converter detects any problem in the detector system, it outputs a FAIL contact signal. If any problem is found, refer to the separate converter User's Manual and promptly take corrective action.

### 4.2.2 Cautions When Stopping or Resuming Operation

If the electrode is stored in the atmosphere for a long time after its operation has been suspended, wash off contamination from the electrode. When resuming sensor operation, perform calibration using standard solutions.

## 5. Inspection and Maintenance

The SC210G Conductivity Detector can be used not only for measuring general solutions (at normal temperatures and where suspended solids etc. that may contaminate the sensor are low levels) but also for measuring the conductivity of solutions under bad conditions, such as high-temperature solutions or those containing corrosive or suspended solids that may adhere to and contaminate the sensor.

When used to measure general solutions, this detector permits maintenance-free operation for extended periods. However, for measurement of solutions under bad conditions, periodic inspection and maintenance (e.g., electrode cleaning) is required to maintain measurement accuracy. The interval for inspection and maintenance as described below should be determined according to the characteristics of the measured solutions.

### 5.1 Conductivity Detector Maintenance

#### 5.1.1 Sensor Cleaning

##### (1) Guidelines for Cleaning

If the measuring solution contains any adhesive component, the electrode will be contaminated by that component. Depending on the nature of the contaminant adhering to the electrode, the same phenomenon as when an electrode with a different cell constant is used occurs so as to increase measurement error; thus, the electrode must be cleaned in specified cycles.

Observe the contaminant adhering to the electrode, determine a cleaning cycle and clean the electrode according to that cycle. Note, however, that electrodes (cell constant:  $0.05 \text{ cm}^{-1}$ ) used for measurement of a solution less than  $200 \mu\text{S/cm}$  hardly need to be cleaned, because not much foreign matter is contained in the measuring solution.

Generally, an electrode (cell constant:  $5 \text{ cm}^{-1}$ ) used for measurement of a solution over  $200 \mu\text{S/cm}$  does not need to be cleaned at short intervals.

Note: The Conductivity Transmitter/Converter has a function to check electrode polarization caused partly by contamination and output an <ABNORMAL> signal (example of SC202: error code Err.1) when it exceeds the allowable limit.  
If Error is detected by this function, clean the electrode and confirm that it is restored to normal condition.

##### (2) Cleaning Procedure

###### <Removing the Conductivity Detector>

When removing the conductivity detector to inspect for contamination and for cleaning, loosen the union nut. Use two wrenches and grip the fixing screw using one, while turning the union nut with the other wrench counterclockwise.

If any pressure exists in the measuring solution, except when a direct insertion type detector with gate valve is used, stop the measuring solution flow and remove it.

When using a direct insertion type detector with gate valve, remove the union nut, pull the probe of the electrode until it comes into contact with the stopper, and close the gate valve. This operation prevents the measuring solution from leaking.

Then, loosen the stopper screw and remove the electrode. (To reinstall, reverse this procedure.)

**<Cleaning an Electrode with a Cell Constant of 0.05 cm<sup>-1</sup>>**

Remove contaminant adhering to the inner and outer electrodes. For contamination of the outer electrode, even removing contamination adhering to the bore only attains its purpose. (For the structure of the electrode, see Section 1.1 and Figure 1.1.)

This electrode is structured so as to allow its outer electrode to be removed by loosening the lock nut. However, the cell constant may change depending on the condition after reassembly; thus, do not disassemble it as a rule.

**<Cleaning an Electrode with a cell constant of 5 cm<sup>-1</sup>>**

This electrode uses glass. To prevent breakage, keep the protective tube fit when cleaning.

The section from which contaminant needs to be removed is the inner side of the glass tube incorporating a platinum electrode. Using a fine rod on which absorbent cotton is wound, rub the surface gently to remove the contaminant.

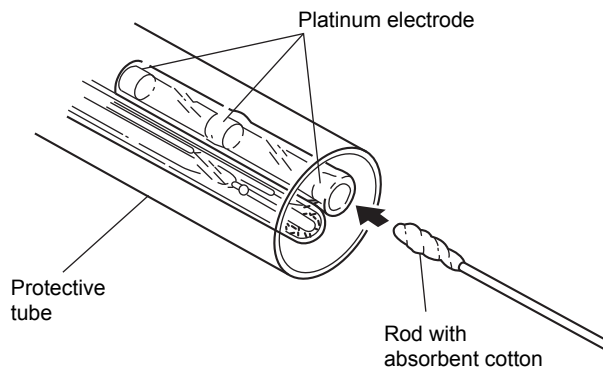

**Figure 5.1** Cleaning an Electrode with a 5 cm<sup>-1</sup> Cell Constant

**5.1.2 Replacing the Sealing O-ring**

If the sealing O-ring is defective and a pressure exists in the measuring solution, the solution will overflow. Accordingly, inspect the fixing screw O-ring for any defect.

In particular, when measuring a high temperature solution, pay attentions to deterioration and, if necessary, replace it periodically.

The sealing O-ring is fit in the position shown in Figure 5.2. Except for the direct insertion type conductivity detector with gate valve, the sealing O-ring can be inspected and replaced by loosening the union nut and removing the electrode.

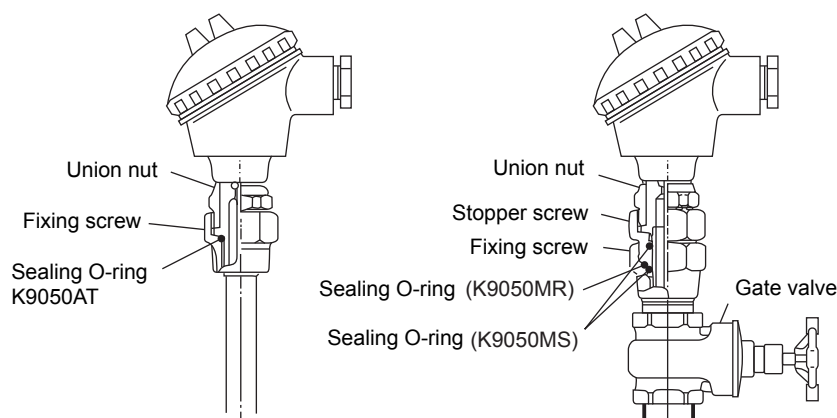

**Figure 5.2** Sealing O-ring

For the direct insertion type conductivity detector with gate valve, proceed as follows for inspection and replacement.

#### Replacing the O-ring for the Direct Insertion Type Conductivity Detector with Gate Valve

- (1) Remove the outer electrode and lock nut

First, remove the spring tip from the outer electrode. Then turn the lock nut clockwise (the direction indicated by arrow 1 in Figure 5.3) using a wrench to loosen it and turn the outer electrode counterclockwise (the direction indicated by arrow 2 in Figure 5.3).

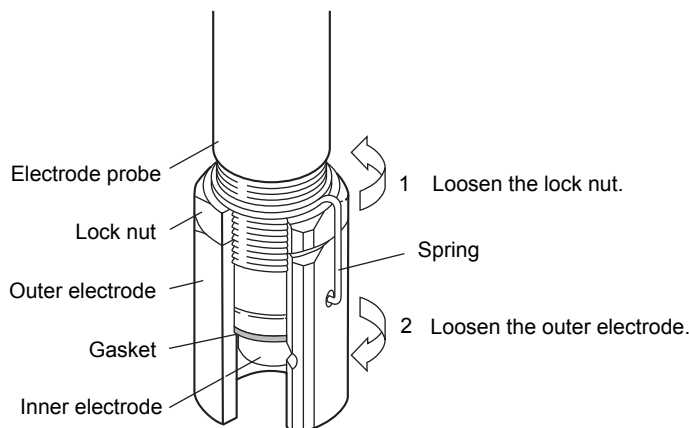

**Figure 5.3 Removing the Outer Electrode and Lock Nut**

- (2) Pull the stopper screw from the electrode probe and replace the O-ring (Parts No.: K9050MS). Replace two at the same time as a rule.
- (3) Replace the stopper screw in the electrode probe. Then replace the spring. Fully tighten the lock nut.
- (4) Replace the outer electrode. (Note that the cell constant changes depending on the installation condition.) Replace the outer electrode and fix to the allowable limit.
- (5) Fasten the spring. First turn the lock nut counterclockwise until it firmly contacts the outer electrode. Then insert both ends of the spring into the holes of the outer electrode.
- (6) The procedure up to (5) completes replacement of the O-ring.

The cell constant may change depending on reassembly after the replacement. As a rule, calibrate with standard solution.

### 5.1.3 Replacement of a Faulty Electrode

If the electrode is judged to be defective, replace the electrode assembly as follows:

- (1) Stop the supply of power to the converter. Loosen the union nut of the conductivity detector (stopper screw for the direct insertion type detector with gate valve) and remove the electrode fixed to the connecting screw.
- (2) Disconnecting the electrode assembly from the dedicated cable

The electrode assembly of the SC210G low / medium-range conductivity detector is provided with a lead wire, which is connected to the dedicated cable through the terminal box. If the SC210G detector is used, remove the lead wires (4) of the electrode assembly connected to the terminal box. Separate the terminal box from the electrode assembly. The electrode assembly is fixed into the terminal box. Insert an Allen wrench into the two holes ( $\varnothing 3.2$  mm) on the collar in the neighbourhood of the union nut and turn it counterclockwise to remove it (see Figure 5.4).

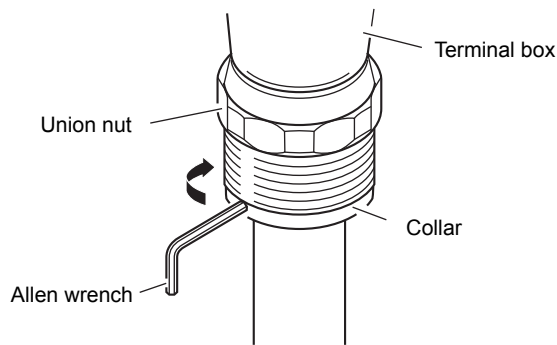

**Figure 5.4** How to Remove Electrode Assembly

- (3) Installing a substitute electrode assembly and reconnecting the wires

For the high-range electrode assembly, replace the union nut on the electrode assembly and fasten it with the holder mounting screws. Then, connect dedicated cable connector.

For the low / medium-range electrode assembly, replace disassembled parts on the electrode assembly, connect it to the terminal box and fasten with mounting screws.

Then, connect each lead wire of the electrode assembly to the specified terminal.

Connect the green lead wire to terminal C1, the yellow lead wire to terminal C2, and the red and black lead wires to terminals T1 and T2.

- (4) Changing the indication of the cell constant

Change the cell constant (CORR. %) indicated on the name plate inside the terminal box to the one of the new electrode assembly installed. The cell constant is indicated on the name plate attached to the cable of the new electrode assembly.

- (5) Enter the cell constant of the installed electrode assembly.

# Customer Maintenance Parts List

## Model SC210G Conductivity Detector

EXA SC

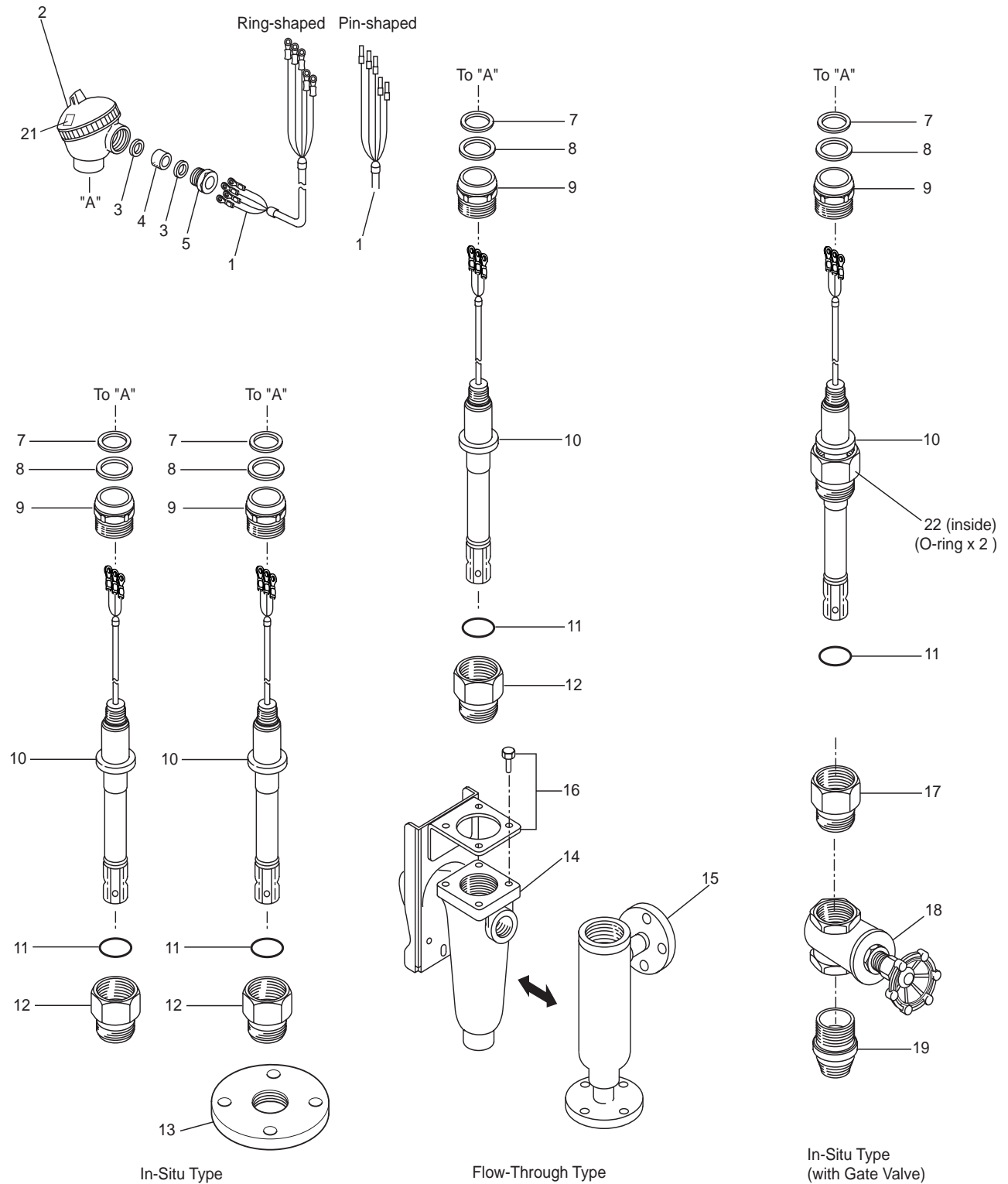

Item	Part No.	Qty	Description
1	—	1	Cable Assembly
	K9315QA		L = 3 m with M4 ring-shaped crimp (SC210G...-03)
	K9315QB		L = 5 m with M4 ring-shaped crimp (SC210G...-05)
	K9315QC		L = 10 m with M4 ring-shaped crimp (SC210G...-10)
	K9315QF		L = 15 m with M4 ring-shaped crimp (SC210G...-15)
	K9315QG		L = 20 m with M4 ring-shaped crimp (SC210G...-20)
	K9315QR		L = 3 m with pin-shaped crimp (SC210G...-AA)
	K9315QS		L = 5 m with pin-shaped crimp (SC210G...-BB)
	K9315QT		L = 10 m with pin-shaped crimp (SC210G...-CC)
	K9315QU		L = 15 m with pin-shaped crimp (SC210G...-DD)
	K9315QV		L = 20 m with pin-shaped crimp (SC210G...-EE)
	K9315QJ		L = 3 m with M3 ring-shaped crimp (SC210G...-Y1)
	K9315QK		L = 5 m with M3 ring-shaped crimp (SC210G...-Y2)
	K9315QL		L = 10 m with M3 ring-shaped crimp (SC210G...-Y3)
	K9315QM		L = 15 m with M3 ring-shaped crimp (SC210G...-Y4)
	K9315QQ		L = 20 m with M3 ring-shaped crimp (SC210G...-Y5)
2	—	1	Cup Assembly
3	G9600DE	2	Washer
4	G9600FD	1	Gasket
5	L9811GG	1	Nut
6	K9149SD	1	Connector (with ANSI connection)
7	K9208TG	1	Washer
8	K9208TH	1	Washer
9	K9050AP	1	Screw
10	—	1	Electrode Assembly, see Table 1 on page 3, and item 21.
11	—	1	O-Ring for sealing
	K9050AT		For SC210G-□-1 (2,3) □□ (Viton®)
	K9050MR		For SC210G-A(B)-40□ (Viton®)
	K9319RN		For SC210G-□-1 (2,3) □□/PF option (Perfluoro-elastomer)
12	—	1	Screw
	K9050AN		Screw Rating : R 1-1/2
	K9050AU		Screw Rating : 1-1/2 NPT male
13	—	1	Flange
	L9840EA		Rating : JIS 10K 15 RF
	L9840QA		Rating : ANSI Class150 2 RF
	L9840KA		Rating : JPI Class150 2 RF
14	—	1	Holder Assembly
	K9053LD		Rating : Rc 1/2 female, SCS14
	K9053JN		Rating : Rc 1/2 female, Polypropylene
	K9053LK		Rating : 1/2 NPT female, SCS14
	K9053JV		Rating : 1/2 NPT female, Polypropylene
15	—	1	Holder Assembly
	K9053MD		Rating : JIS 10K 15 RF flange, SCS14
	K9053KG		Rating : JIS 10K 15 FF flange, Polypropylene
	K9053PB		Rating : ANSI Class150 2 RF flange, SCS14
	K9053PB		Rating : ANSI Class150 2 FF flange, Polypropylene
16	K9053JW	1	Bracket Assembly (Holder assembly : Polypropylene)
17	K9050TP	1	Screw
18	L9852AE	1	Valve
19	—	1	Nipple
	L9832BG		Rating : R 1-1/4
	L9832BH		Rating : 1-1/4 NPT male
20	K9053LR	1	Mounting hardware for /SS option
21	K9053AT	1	Name Plate (CORR. %) When you purchase item 10, have to purchase with this name plate.
22	—		O-Ring for sealing of gate valve type
	K9050MS	2	For SC210G-A(B)-40□ (Viton®)
	K9319RR	2	For SC210G-A(B)-40□/PF option (Perfluoro-elastomer)

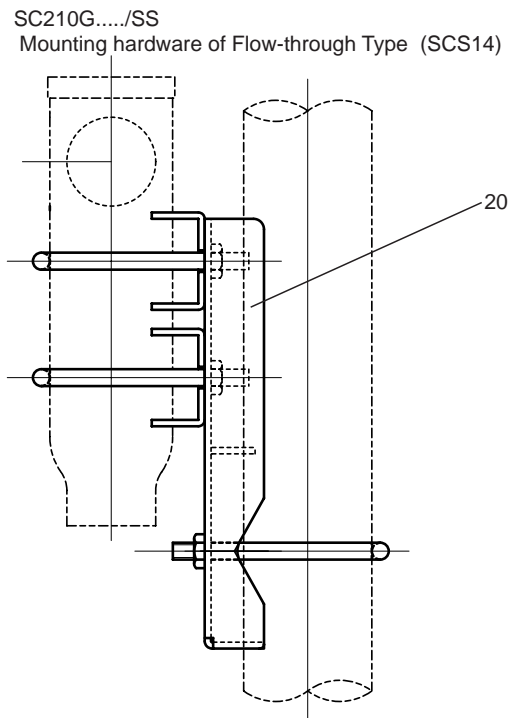

Table 1 (For Item 10 Electrode Assembly)

Parts No.	Description
K9208EA	150 mm electrode Assembly (C=0.05 cm <sup>-1</sup> ) for SC210G-A
K9208EB	500 mm electrode Assembly (C=0.05 cm <sup>-1</sup> ) for SC210G-A
K9208EC	1000 mm electrode Assembly (C=0.05 cm <sup>-1</sup> ) for SC210G-A
K9208ED	1500 mm electrode Assembly (C=0.05 cm <sup>-1</sup> ) for SC210G-A
K9208EE	2000 mm electrode Assembly (C=0.05 cm <sup>-1</sup> ) for SC210G-A
K9208EF	300 mm electrode Assembly (C=0.05 cm <sup>-1</sup> ) for SC210G-A
K9315NA	150 mm electrode Assembly (C=0.05 cm <sup>-1</sup> ) with perfluoro-elastomer, for SC210G-A
K9315NB	500 mm electrode Assembly (C=0.05 cm <sup>-1</sup> ) with perfluoro-elastomer, for SC210G-A
K9315NC	1000 mm electrode Assembly (C=0.05 cm <sup>-1</sup> ) with perfluoro-elastomer, for SC210G-A
K9315ND	1500 mm electrode Assembly (C=0.05 cm <sup>-1</sup> ) with perfluoro-elastomer, for SC210G-A
K9315NE	2000 mm electrode Assembly (C=0.05 cm <sup>-1</sup> ) with perfluoro-elastomer, for SC210G-A
K9315NF	300 mm electrode Assembly (C=0.05 cm <sup>-1</sup> ) with perfluoro-elastomer, for SC210G-A
K9208KA	Electrode Assembly (C=0.05 cm <sup>-1</sup> ) of gate valve type for SC210G-A
K9315NN	Electrode Assembly (C=0.05 cm <sup>-1</sup> ) of gate valve type with perfluoro-elastomer for SC210G-A
K9208JA	150 mm electrode Assembly (C=5 cm <sup>-1</sup> ) for SC210G-B
K9208JB	500 mm electrode Assembly (C=5 cm <sup>-1</sup> ) for SC210G-B
K9208JC	1000 mm electrode Assembly (C=5 cm <sup>-1</sup> ) for SC210G-B
K9208JD	1500 mm electrode Assembly (C=5 cm <sup>-1</sup> ) for SC210G-B
K9208JE	2000 mm electrode Assembly (C=5 cm <sup>-1</sup> ) for SC210G-B
K9208JF	300 mm electrode Assembly (C=5 cm <sup>-1</sup> ) for SC210G-B
K9315NG	150 mm electrode Assembly (C=5 cm <sup>-1</sup> ) with perfluoro-elastomer, for SC210G-B
K9315NH	500 mm electrode Assembly (C=5 cm <sup>-1</sup> ) with perfluoro-elastomer, for SC210G-B
K9315NJ	1000 mm electrode Assembly (C=5 cm <sup>-1</sup> ) with perfluoro-elastomer, for SC210G-B
K9315NK	1500 mm electrode Assembly (C=5 cm <sup>-1</sup> ) with perfluoro-elastomer, for SC210G-B
K9315NL	2000 mm electrode Assembly (C=5 cm <sup>-1</sup> ) with perfluoro-elastomer, for SC210G-B
K9315NM	300 mm electrode Assembly (C=5 cm <sup>-1</sup> ) with perfluoro-elastomer, for SC210G-B
K9208MA	Electrode Assembly (C=5 cm <sup>-1</sup> ) of gate valve type for SC210G-B
K9315NP	Electrode Assembly (C=5 cm <sup>-1</sup> ) of gate valve type with perfluoro-elastomer for SC210G-B

Note "C" means cell constant.

---

# Revision Information

- Title : Conductivity Metering System Model SC210G Conductivity Detector
- Manual No. : IM 12D08G03-01E

## Jun. 2011/5th Edition

P1 Manual No. of FLXA21 added; P1-2 FLXA21 added to combination of detector and converters.  
P1-3 Some of description for MS-code modified (M4 ring description); P1-4 Some of description for spare parts modified (M4 ring description); P3-6 FLXA21 added to Figure 3.9.  
P2 of CMPL 12D08G03-01E modified (M4 ring description for cable).

## Mar. 2010/4th Edition

P1-3 Note of \*7 added to MS-code on Section 1.2.2. Dimension of optional cable inlet adapter for "/ANSI" added to Figure 1.5.

## Jul. 2009/3rd Edition

P3-2 Comment of Figure 3.1 modified; P3-3 Comment of Figure 3.3 modified; P3-4 Note for terminal box direction adjustment added to section 3.1.3; P3-7 Some error of section 3.3 corrected; P5-3 Figure 5.2 modified; CMPL 12D08F00-01E 6th edition revised, because parts no. of item 10 electrode assembly modified, and item 22 added.

## Jan. 2008/2nd Edition

Ring terminals added for SC450G converter.

## Jul. 2007/1st Edition

Newly published

- 
- If you want to have more information about Yokogawa products, you can visit Yokogawa's home page at the following web site.  
Home page: <http://www.yokogawa.com/an>
-

